

MM5452/MM5453 Liquid Crystal Display Drivers

 Check for Samples: [MM5452](#), [MM5453](#)

FEATURES

- Serial Data Input
- No Load Signal Required
- **DATA ENABLE** (MM5452)
- Wide Power Supply Operation
- TTL Compatibility
- 32 or 33 Outputs
- Alphanumeric and Bar Graph Capability
- Cascaded Operation Capability

APPLICATIONS

- COPS™ or Microprocessor Displays
- Industrial Control Indicator
- Digital Clock, Thermometer, Counter, Voltmeter
- Instrumentation Readouts
- Remote Displays

Block Diagram

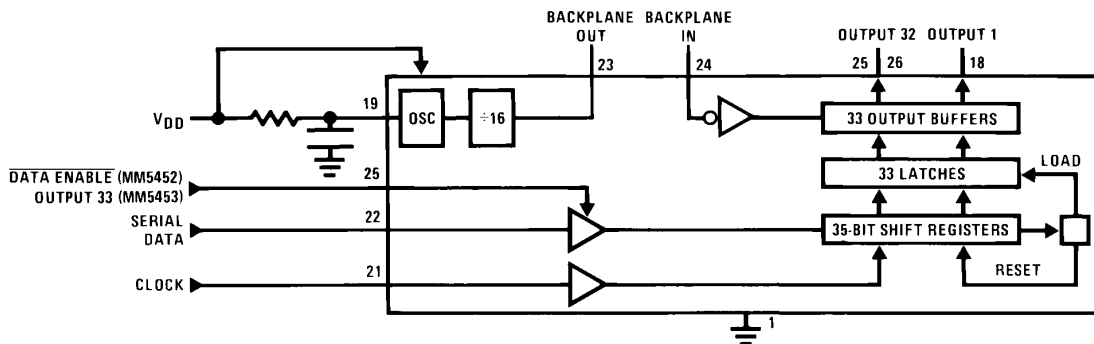

Figure 1.



These devices have limited built-in ESD protection. The leads should be shorted together or the device placed in conductive foam during storage or handling to prevent electrostatic damage to the MOS gates.



Please be aware that an important notice concerning availability, standard warranty, and use in critical applications of Texas Instruments semiconductor products and disclaimers thereto appears at the end of this data sheet.

All trademarks are the property of their respective owners.

Absolute Maximum Ratings ⁽¹⁾⁽²⁾

Voltage at Any Pin, Referenced to Gnd	-0.3V to +10V
Storage Temperature	-65°C to +150°C
Power Dissipation at 25°C	350mW
Power Dissipation at 70°C	300mW
Junction Temperature	+150°C
Lead Temperature (Soldering, 10s)	300°C

- (1) "Absolute Maximum Ratings" are those values beyond which the safety of the device cannot be ensured. They are not meant to imply that the devices should be operated at these limits. The table of "Electrical Characteristics" specifies conditions of device operation.
- (2) If Military/Aerospace specified devices are required, please contact the TI Sales Office/Distributors for availability and specifications.

Recommended Operating Conditions

V _{DD}	3V to 10V
Operating Temperature	-40°C to 85°C

Electrical Characteristics

T_A within operating range, V_{DD} = 3.0V to 10V, V_{SS} = 0V unless otherwise specified.

Parameter	Conditions	Min	Typ	Max	Units
Supply Voltage, V _{DD}		3		10	V
Average Supply Current, I _{DD}	All Outputs Open, Clock=Gnd, Data=Gnd, OSC=Gnd, BP_IN @ 32Hz				
	V _{DD} = 5V			10	μA
	V _{DD} = 10V			40	μA
Input Logical '0' Voltage, V _{IL}	V _{DD} = 3V			0.4	V
	V _{DD} = 5V			0.8	V
	V _{DD} = 10V			0.8	V
Input Logical '1' Voltage, V _{IH}	V _{DD} = 3V	2.0			V
	V _{DD} = 5V	2.0			V
	V _{DD} = 10V	8.0			V
Segment Sink Current, I _{OL}	V _{DD} = 3V, V _{OUT} = 0.3V	-20	-40		μA
Segment Source Current, I _{OH}	V _{DD} = 3V, V _{OUT} = 2.7V	20	40		μA
Backplane Out Sink Current, I _{OL}	V _{DD} = 3V, V _{OUT} = 0.3V	-320	-500		μA
Backplane Out Source Current, I _{OH}	V _{DD} = 3V, V _{OUT} = 2.7V	320	500		μA
Segment Output Offset Voltage	Segment Load = 250pF ⁽¹⁾			+/-50	mV
Backplane Output Offset Voltage	Backplane Load = 8750pF ⁽¹⁾			+/-50	mV
Backplane Out Frequency	R _{OSC_IN} = 50kΩ, C _{OSC_IN} = 0.01μF		75		Hz
Clock Input Frequency, f _{CLOCK} ⁽²⁾	V _{DD} = 3V ^{(1) (3)}			500	kHz
	V _{DD} = 5V ⁽¹⁾			750	kHz
	V _{DD} = 10V ⁽¹⁾			1.0	MHz
Clock Input Duty Cycle ⁽²⁾		40		60	%
Data Input Set-Up Time, t _{DS}		300			ns
Data Input Hold Time, t _{DH}		300			ns
DataEnable Set-up Time, t _{DES}		100			ns

- (1) This parameter is ensured (but not production tested) over the operating temperature range and the operating supply voltage range. Not to be used in Q.A. testing.
- (2) Clock input rise time (t_r) and fall time (t_f) must not exceed 300ns
- (3) AC input waveform for test purposes: t_r ≤ 20ns, t_f ≤ 20ns, f_{CLOCK} = 500kHz, Duty Cycle = 50% ±10%

Connection Diagram

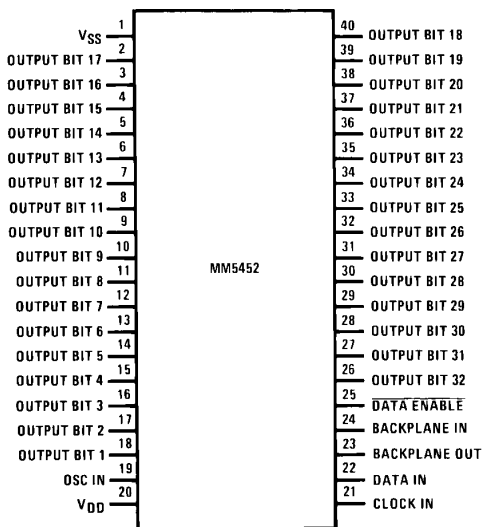

Figure 2. Top View
See Package Number NFJ0040A

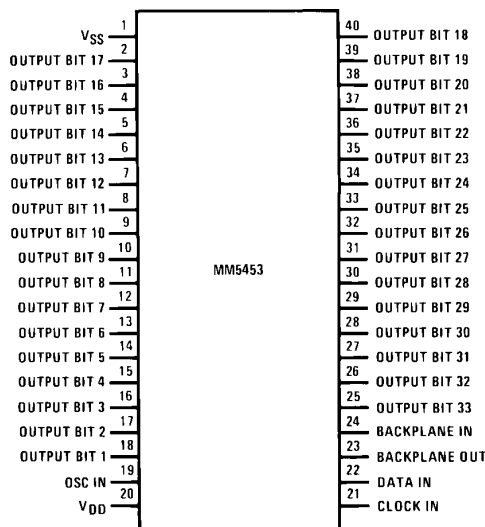

Figure 3. Top View
See Package Number NFJ0040A

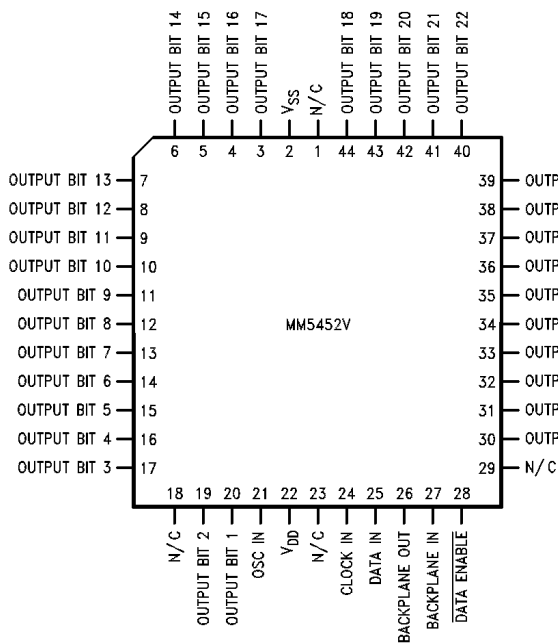

Figure 4. Top View
See Package Number FN0044A

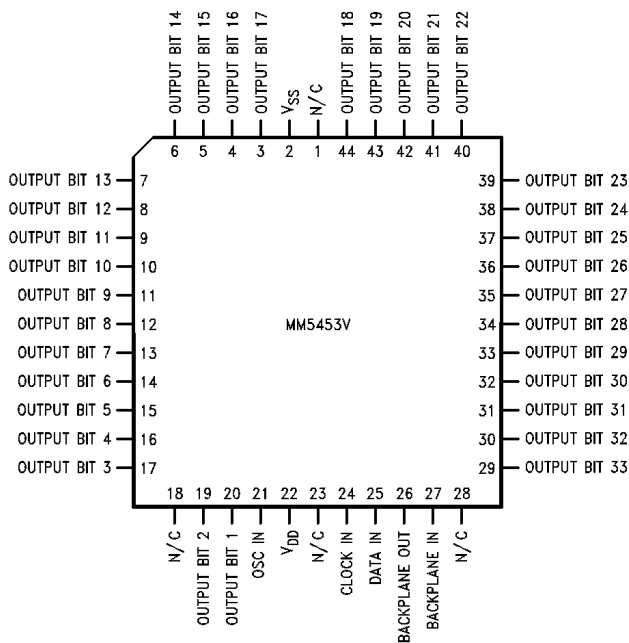

Figure 5. Top View
See Package Number FN0044A

FUNCTIONAL DESCRIPTION

The MM5452 is specifically designed to operate 4½-digit 7-segment displays with minimal interface with the display and the data source. Serial data transfer from the data source to the display driver is accomplished with 2 signals, serial data and clock. Since the MM5452 does not contain a character generator, the formatting of the segment information must be done prior to inputting the data to the MM5452. Using a format of a leading “1” followed by the 32 data bits allows data transfer without an additional load signal. The 32 data bits are latched after the 36th clock is complete, thus providing non-multiplexed, direct drive to the display. Outputs change only if the serial data bits differ from the previous time.

A block diagram is shown in Figure 1. For the MM5452 a DATA ENABLE is used instead of the 33rd output. If the DATA ENABLE signal is not required, the 33rd output can be brought out. This is the MM5453 device.

Figure 7 shows the input data format. A start bit of logical “1” precedes the 32 bits of data. At the 36th clock a LOAD signal is generated synchronously with the high state of the clock, which loads the 32 bits of the shift registers into the latches. At the low state of the clock a RESET signal is generated which clears all the shift registers for the next set of data. The shift registers are static master-slave configuration. There is no clear for the master portion of the first shift register, thus allowing continuous operation.

If the clock is not continuous, there must be at least a complete set of 36 clocks otherwise the shift registers will not load and clear.

Bit 1 is the first bit following the start bit and it will appear on device pin 18 of the MM5452N and MM5453N, and on device pin 20 of the MM5452V and MM5453V.

Figure 6 shows the timing relationships between data, clock and DATA ENABLE.

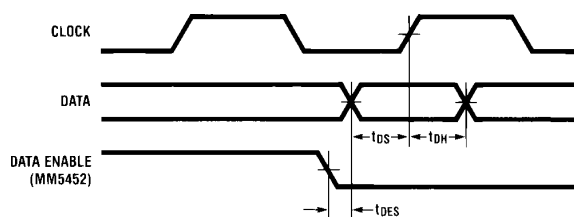

Figure 6. Timing Diagram

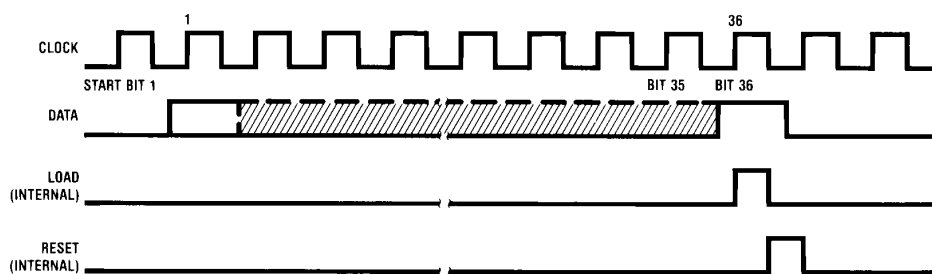
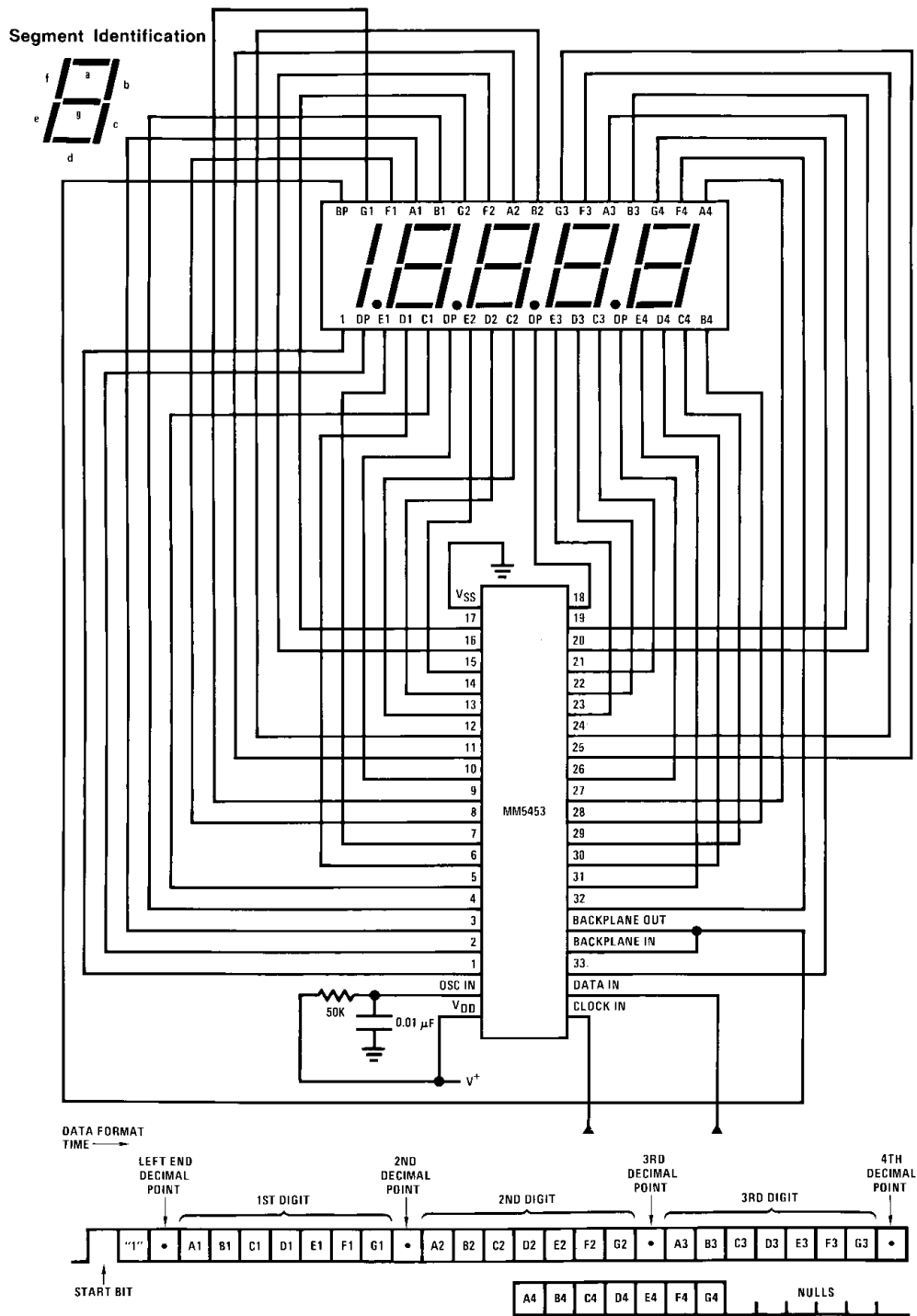

Figure 7. Input Data Format

Figure 8 shows a typical application. Note how the input data maps to the output pins and the display. The MM5452 and MM5453 do not have format restrictions, as all outputs are controllable. The application assumes a specific display pinout. Different display/driver connection patterns will, of course, yield a different input data format.



Consult LCD manufacturer's data sheet for specific pinouts.

Figure 8. Typical 4½-Digit Display Application

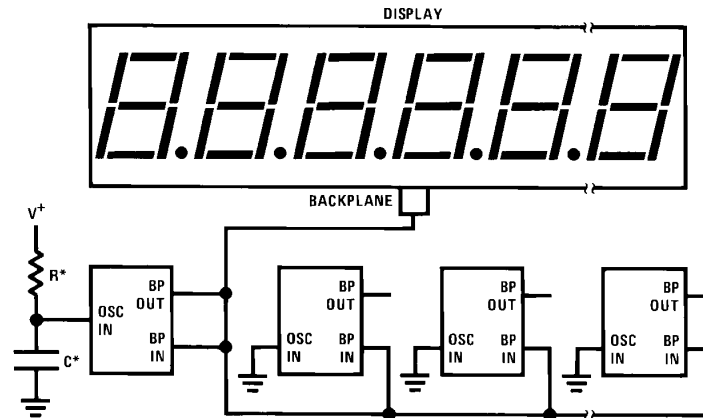

*The minimum recommended value for R for the oscillator input is 9 k Ω . An RC time constant of approximately 4.91×10^{-4} should produce a backplane frequency between 30 Hz and 150 Hz.

Figure 9. Parallel Backplane Outputs

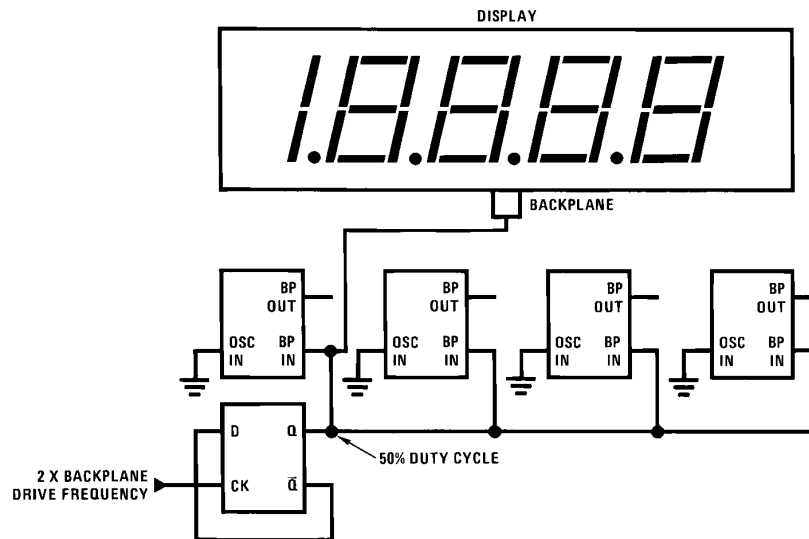

Figure 10. External Backplane Clock

Figure 11 shows a four wire remote display that takes advantage of the device's serial input to move many bits of display information on a few wires.

USING AN EXTERNAL CLOCK

The MM5452/MM5453 LCD Drivers can be used with an externally supplied clock, provided it has a duty cycle of 50%. Deviations from a 50% duty cycle result in an offset voltage on the LCD. In Figure 10, a flip-flop is used to assure a 50% duty cycle. The oscillator input is grounded to prevent oscillation and reduce current consumptions in the chips. The oscillator is not used.

Using an external clock allows synchronizing the display drive with AC power, internal clocks, or DVM integration time to reduce interference from the display.

Figure 12 is a general block diagram that shows how the device's serial input can be used to advantage in an analog display. The analog voltage input is compared with a staircase voltage generated by a counter and a digital-to-analog converter or resistor array. The result of this comparison is clocked into the MM5452, MM5453. The next clock pulse increments the staircase and clocks the new data in.

With a buffer amplifier, the same staircase waveform can be used for many displays. The digital-to-analog converter need not be linear; logarithmic or other non-linear functions can be displayed by using weighted resistors or special DACs. This system can be used for status indicators, spectrum analyzers, audio level and power meters, tuning indicators, and other applications.

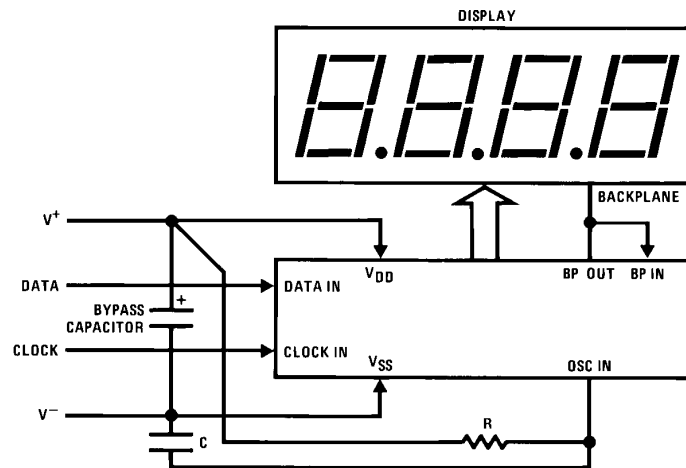
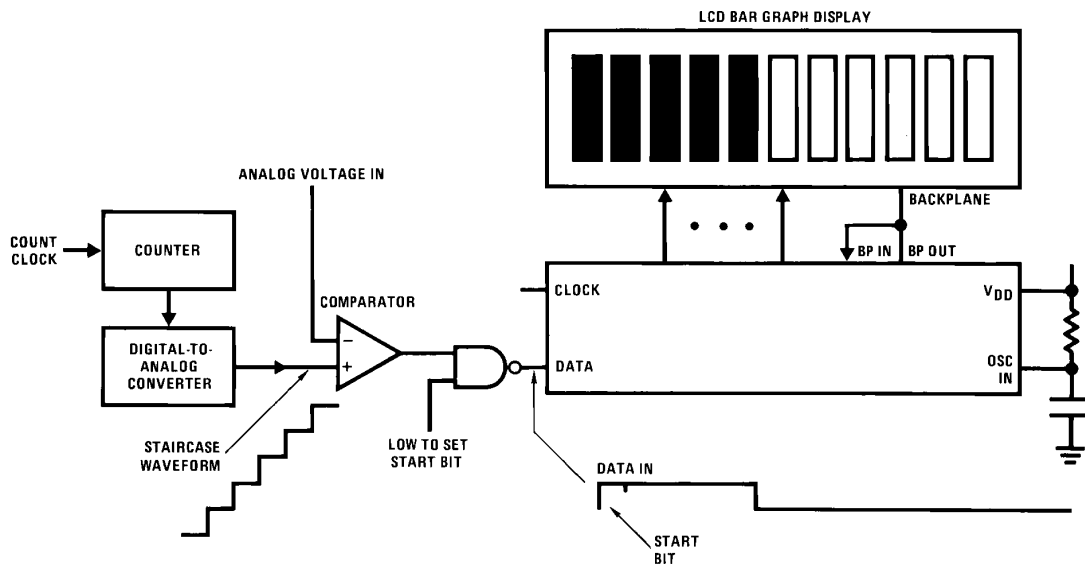

Figure 11. Four Wire Remote Display



Data is high until staircase > input

Figure 12. Analog Display

REVISION HISTORY

Changes from Revision B (March 2013) to Revision C	Page
• Changed layout of National Data Sheet to TI format	7

PACKAGING INFORMATION

Orderable Device	Status (1)	Package Type	Package Drawing	Pins	Package Qty	Eco Plan (2)	Lead/Ball Finish (6)	MSL Peak Temp (3)	Op Temp (°C)	Device Marking (4/5)	Samples
MM5452N/NOPB	LIFEBUY	PDIP	NFJ	40	9	Green (RoHS & no Sb/Br)	CU SN	Level-1-NA-UNLIM	-40 to 85	MM5452N	
MM5452V	NRND	PLCC	FN	44	25	TBD	Call TI	Call TI	-40 to 85	MM5452V	
MM5452V/NOPB	ACTIVE	PLCC	FN	44	25	Green (RoHS & no Sb/Br)	CU SN	Level-3-245C-168 HR	-40 to 85	MM5452V	Samples
MM5452VX/NOPB	ACTIVE	PLCC	FN	44	500	Green (RoHS & no Sb/Br)	CU SN	Level-3-245C-168 HR	-40 to 85	MM5452V	Samples
MM5453N	NRND	PDIP	NFJ	40	9	TBD	Call TI	Call TI	-40 to 85	MM5453N	
MM5453N/NOPB	LIFEBUY	PDIP	NFJ	40	9	Green (RoHS & no Sb/Br)	CU SN	Level-1-NA-UNLIM	-40 to 85	MM5453N	
MM5453V/NOPB	ACTIVE	PLCC	FN	44	25	Green (RoHS & no Sb/Br)	CU SN	Level-3-245C-168 HR	-40 to 85	MM5453V	Samples
MM5453VX/NOPB	ACTIVE	PLCC	FN	44	500	Green (RoHS & no Sb/Br)	CU SN	Level-3-245C-168 HR	-40 to 85	MM5453V	Samples

(1) The marketing status values are defined as follows:

ACTIVE: Product device recommended for new designs.

LIFEBUY: TI has announced that the device will be discontinued, and a lifetime-buy period is in effect.

NRND: Not recommended for new designs. Device is in production to support existing customers, but TI does not recommend using this part in a new design.

PREVIEW: Device has been announced but is not in production. Samples may or may not be available.

OBSELETE: TI has discontinued the production of the device.

(2) **RoHS:** TI defines "RoHS" to mean semiconductor products that are compliant with the current EU RoHS requirements for all 10 RoHS substances, including the requirement that RoHS substance do not exceed 0.1% by weight in homogeneous materials. Where designed to be soldered at high temperatures, "RoHS" products are suitable for use in specified lead-free processes. TI may reference these types of products as "Pb-Free".

RoHS Exempt: TI defines "RoHS Exempt" to mean products that contain lead but are compliant with EU RoHS pursuant to a specific EU RoHS exemption.

Green: TI defines "Green" to mean the content of Chlorine (Cl) and Bromine (Br) based flame retardants meet JS709B low halogen requirements of <=1000ppm threshold. Antimony trioxide based flame retardants must also meet the <=1000ppm threshold requirement.

(3) MSL, Peak Temp. - The Moisture Sensitivity Level rating according to the JEDEC industry standard classifications, and peak solder temperature.

(4) There may be additional marking, which relates to the logo, the lot trace code information, or the environmental category on the device.

(5) Multiple Device Markings will be inside parentheses. Only one Device Marking contained in parentheses and separated by a "~" will appear on a device. If a line is indented then it is a continuation of the previous line and the two combined represent the entire Device Marking for that device.

⁽⁶⁾ Lead/Ball Finish - Orderable Devices may have multiple material finish options. Finish options are separated by a vertical ruled line. Lead/Ball Finish values may wrap to two lines if the finish value exceeds the maximum column width.

Important Information and Disclaimer: The information provided on this page represents TI's knowledge and belief as of the date that it is provided. TI bases its knowledge and belief on information provided by third parties, and makes no representation or warranty as to the accuracy of such information. Efforts are underway to better integrate information from third parties. TI has taken and continues to take reasonable steps to provide representative and accurate information but may not have conducted destructive testing or chemical analysis on incoming materials and chemicals. TI and TI suppliers consider certain information to be proprietary, and thus CAS numbers and other limited information may not be available for release.

In no event shall TI's liability arising out of such information exceed the total purchase price of the TI part(s) at issue in this document sold by TI to Customer on an annual basis.

MECHANICAL DATA

NFJ0040A

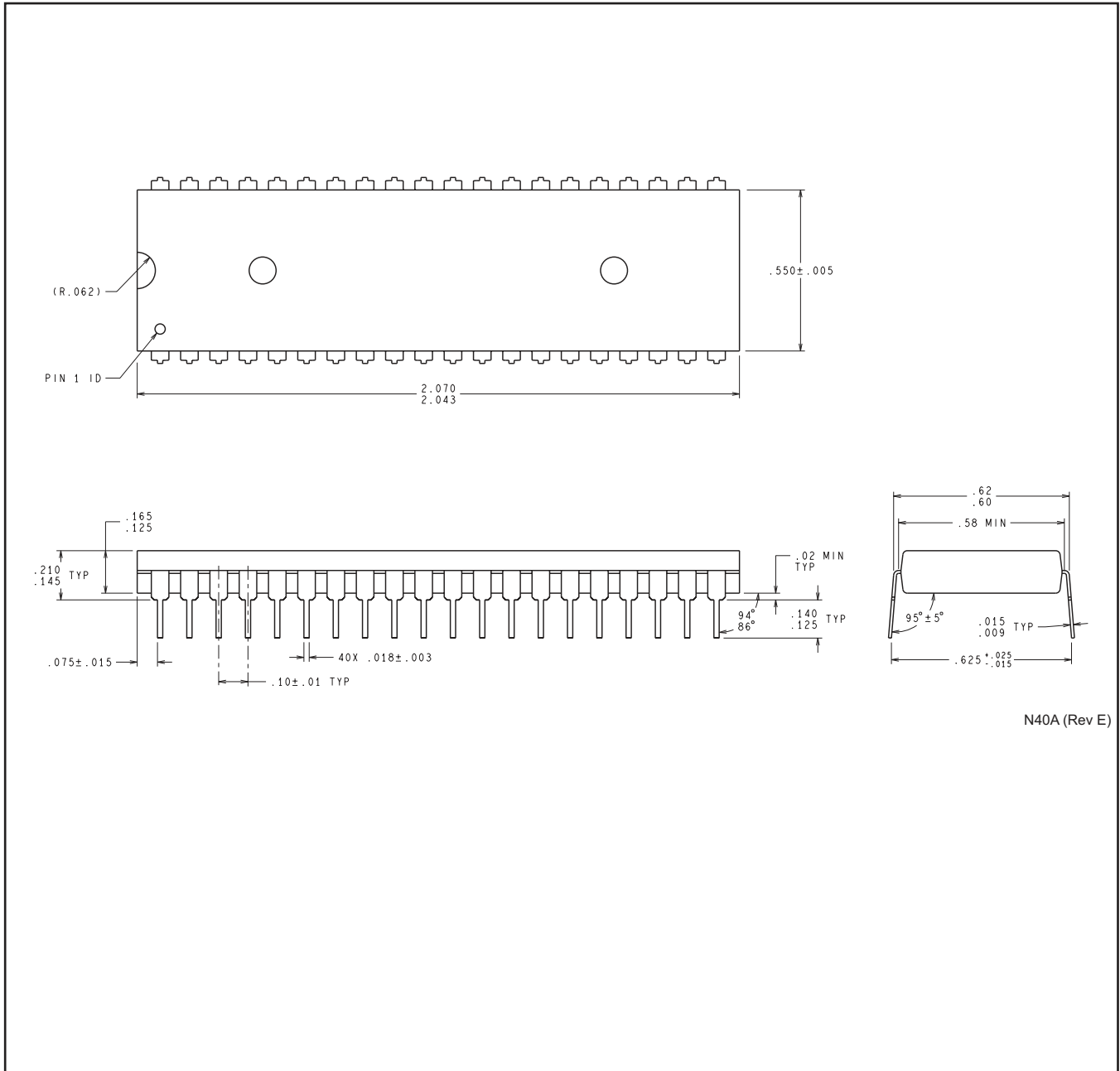

N40A (Rev E)

FN 44

GENERIC PACKAGE VIEW

PLCC - 4.57 mm max height

PLASTIC CHIP CARRIER



Images above are just a representation of the package family, actual package may vary.
Refer to the product data sheet for package details.

4040005-4/C

FN0044A



PACKAGE OUTLINE

PLCC - 4.57 mm max height

PLASTIC CHIP CARRIER

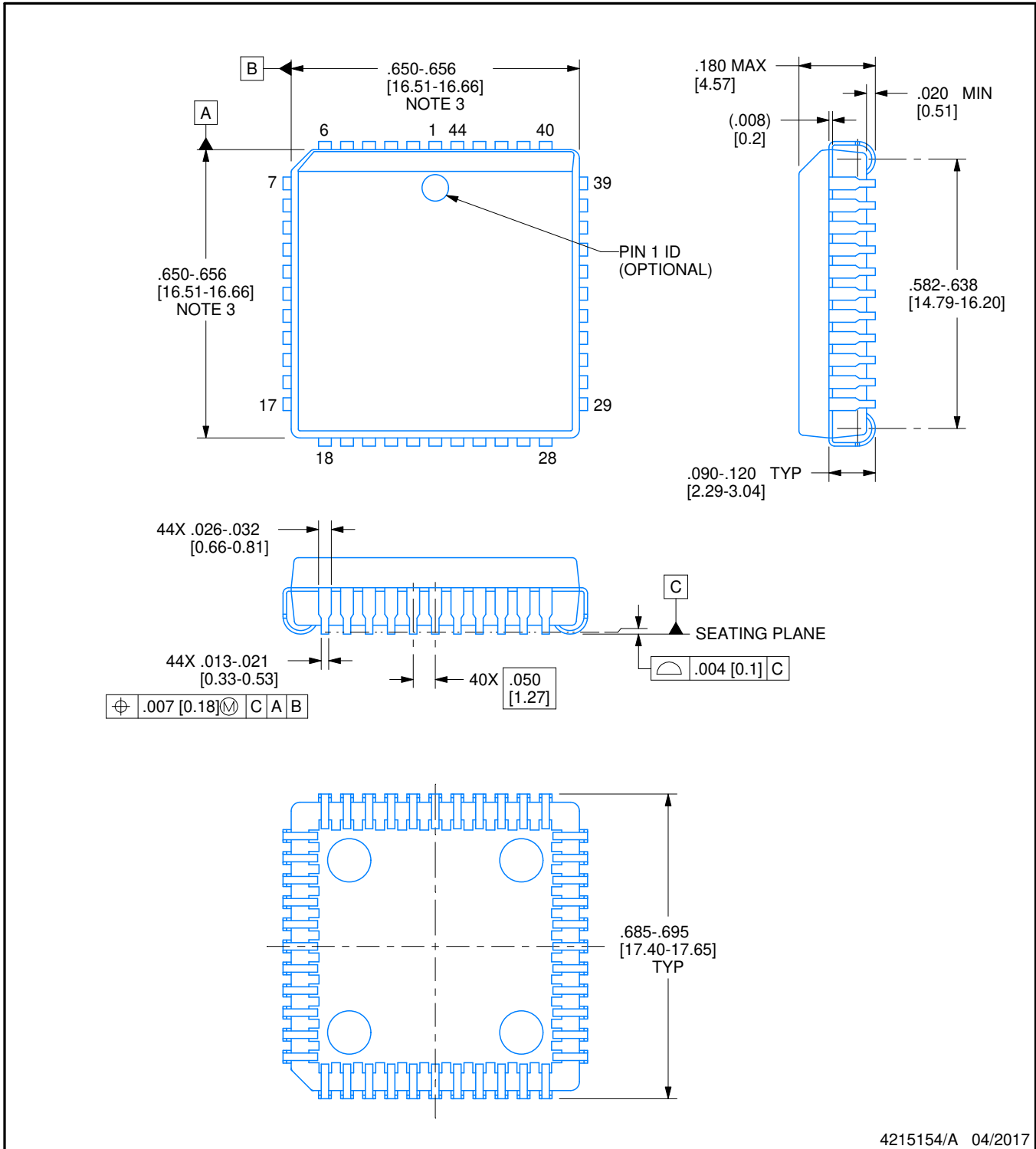

4215154/A 04/2017

NOTES:

1. All linear dimensions are in inches. Any dimensions in brackets are in millimeters. Any dimensions in parenthesis are for reference only. Controlling dimensions are in inches. Dimensioning and tolerancing per ASME Y14.5M.
2. This drawing is subject to change without notice.
3. Dimension does not include mold protrusion. Maximum allowable mold protrusion .01 in [0.25 mm] per side.
4. Reference JEDEC registration MS-018.

EXAMPLE BOARD LAYOUT

FN0044A

PLCC - 4.57 mm max height

PLASTIC CHIP CARRIER

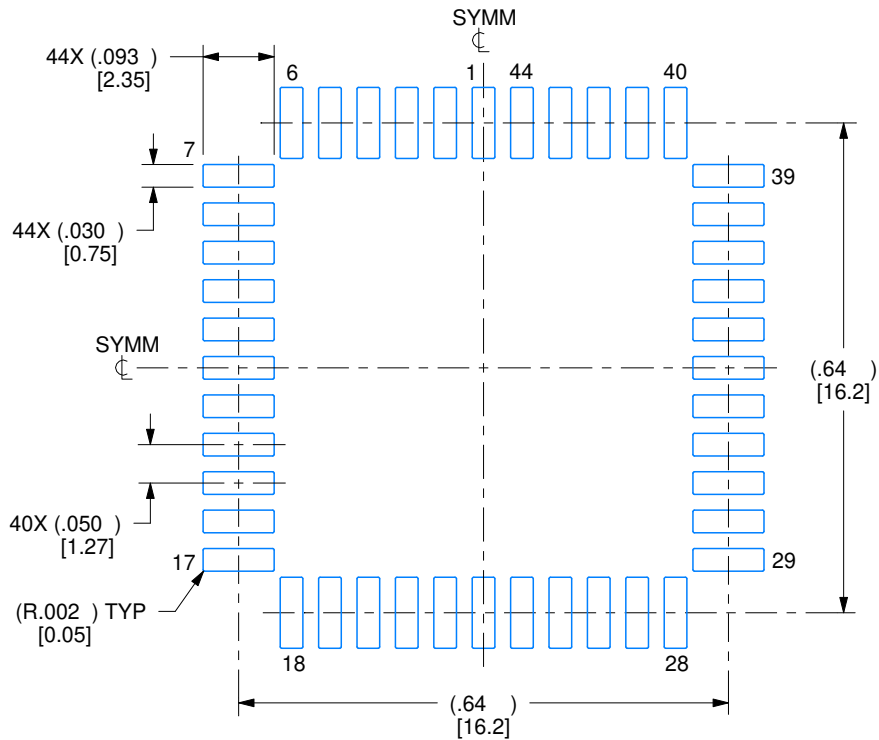

LAND PATTERN EXAMPLE
EXPOSED METAL SHOWN
SCALE:4X

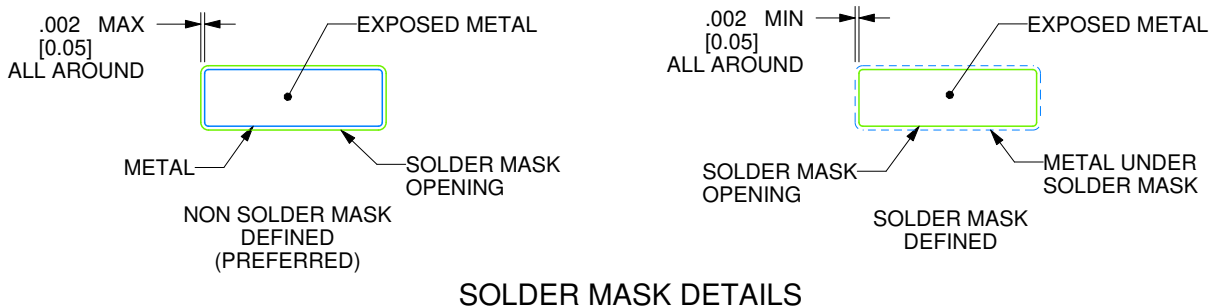

SOLDER MASK DETAILS

4215154/A 04/2017

NOTES: (continued)

- 5. Publication IPC-7351 may have alternate designs.
- 6. Solder mask tolerances between and around signal pads can vary based on board fabrication site.

EXAMPLE STENCIL DESIGN

FN0044A

PLCC - 4.57 mm max height

PLASTIC CHIP CARRIER

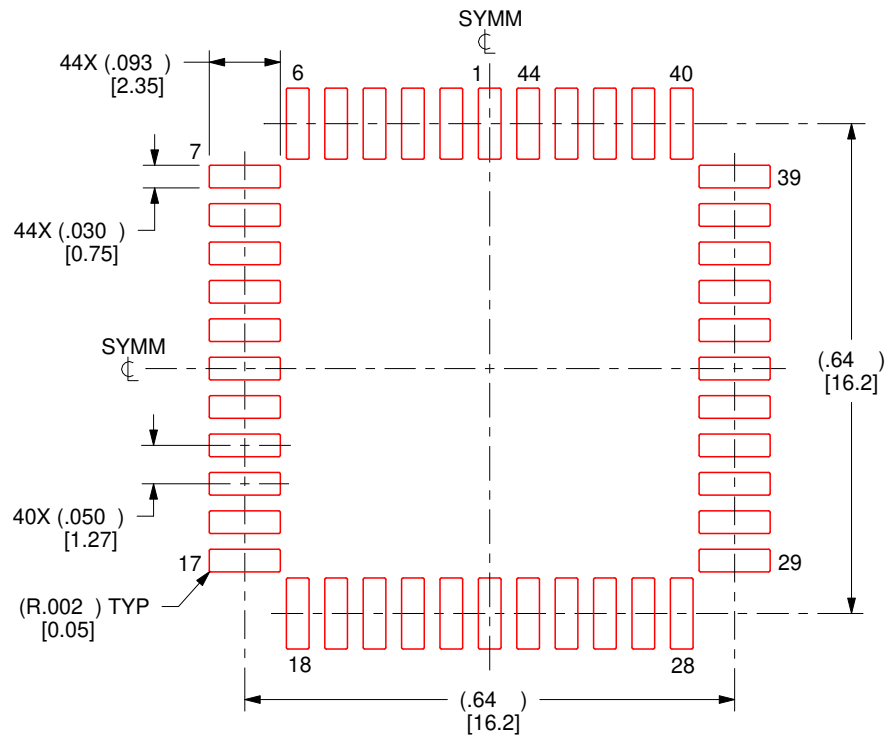

SOLDER PASTE EXAMPLE
BASED ON 0.125 mm THICK STENCIL
SCALE:4X

4215154/A 04/2017

NOTES: (continued)

7. Laser cutting apertures with trapezoidal walls and rounded corners may offer better paste release. IPC-7525 may have alternate design recommendations.
8. Board assembly site may have different recommendations for stencil design.

IMPORTANT NOTICE AND DISCLAIMER

TI PROVIDES TECHNICAL AND RELIABILITY DATA (INCLUDING DATASHEETS), DESIGN RESOURCES (INCLUDING REFERENCE DESIGNS), APPLICATION OR OTHER DESIGN ADVICE, WEB TOOLS, SAFETY INFORMATION, AND OTHER RESOURCES "AS IS" AND WITH ALL FAULTS, AND DISCLAIMS ALL WARRANTIES, EXPRESS AND IMPLIED, INCLUDING WITHOUT LIMITATION ANY IMPLIED WARRANTIES OF MERCHANTABILITY, FITNESS FOR A PARTICULAR PURPOSE OR NON-INFRINGEMENT OF THIRD PARTY INTELLECTUAL PROPERTY RIGHTS.

These resources are intended for skilled developers designing with TI products. You are solely responsible for (1) selecting the appropriate TI products for your application, (2) designing, validating and testing your application, and (3) ensuring your application meets applicable standards, and any other safety, security, or other requirements. These resources are subject to change without notice. TI grants you permission to use these resources only for development of an application that uses the TI products described in the resource. Other reproduction and display of these resources is prohibited. No license is granted to any other TI intellectual property right or to any third party intellectual property right. TI disclaims responsibility for, and you will fully indemnify TI and its representatives against, any claims, damages, costs, losses, and liabilities arising out of your use of these resources.

TI's products are provided subject to TI's Terms of Sale (www.ti.com/legal/termsofsale.html) or other applicable terms available either on ti.com or provided in conjunction with such TI products. TI's provision of these resources does not expand or otherwise alter TI's applicable warranties or warranty disclaimers for TI products.

Mailing Address: Texas Instruments, Post Office Box 655303, Dallas, Texas 75265
Copyright © 2018, Texas Instruments Incorporated