

REVISIONS					
#	CLM	DESCRIPTION	DATE	OWN	APVD
A5		Released as per ECR-07-012890	12-06-07	SK	TS
A6		REVISED PER ECO-09-027197	29DEC09	KK	AEG
A7		REVISED PER ECR-17-013084	08JAN2018	NC	MKO

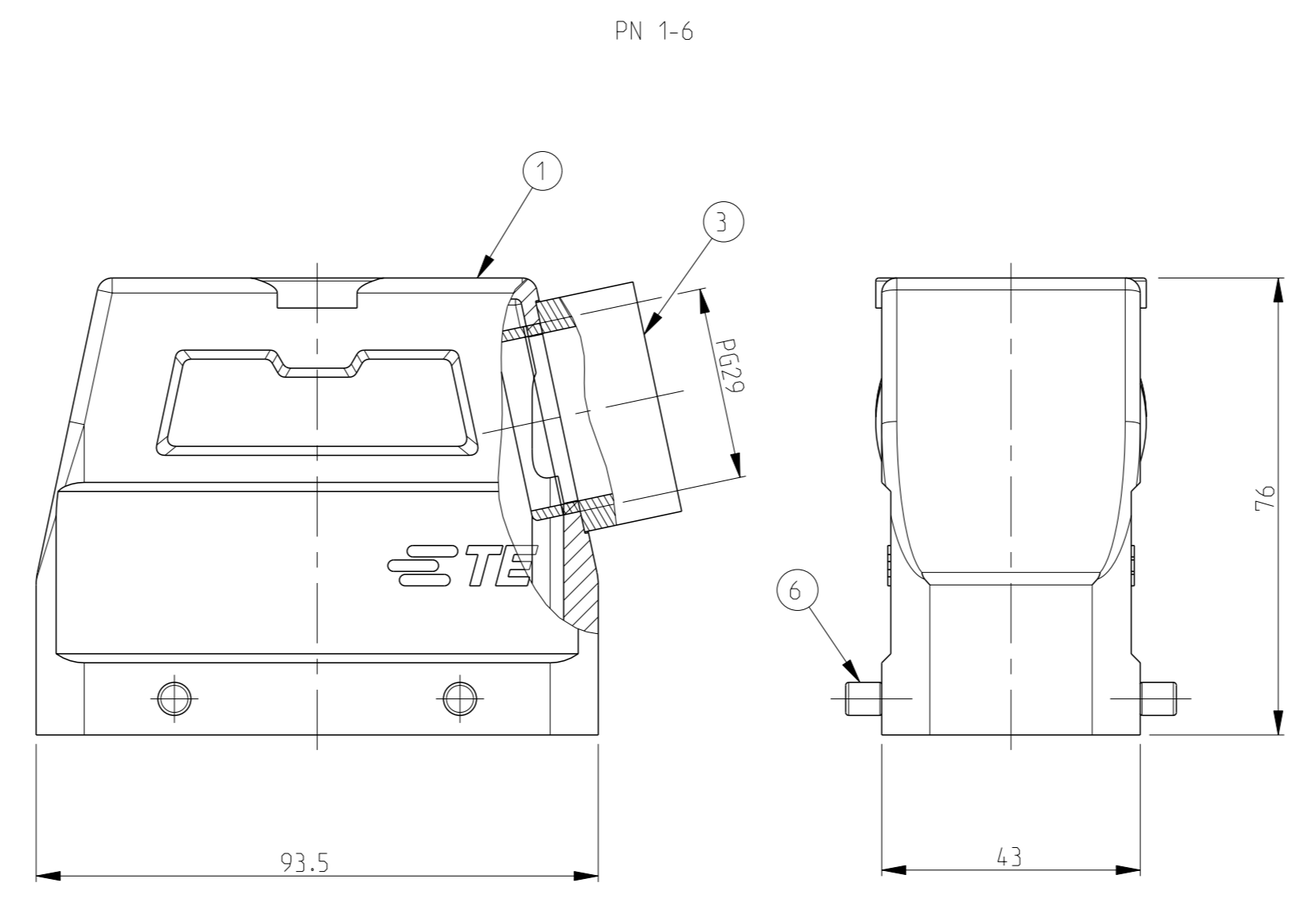

- NOTES
- 1 Material: Housing: aluminium diecasting alloy
 - 2 Surface:- powder varnish-grey
Varnish black
 - 3 Varnish on the inside not necessarily
 - 4 Packaging quantity 5 pieces
 - 5 OBSOLETE PARTS: OBSOLETE C IS STREAMLINING PER D.RENAUD/D.SINISI

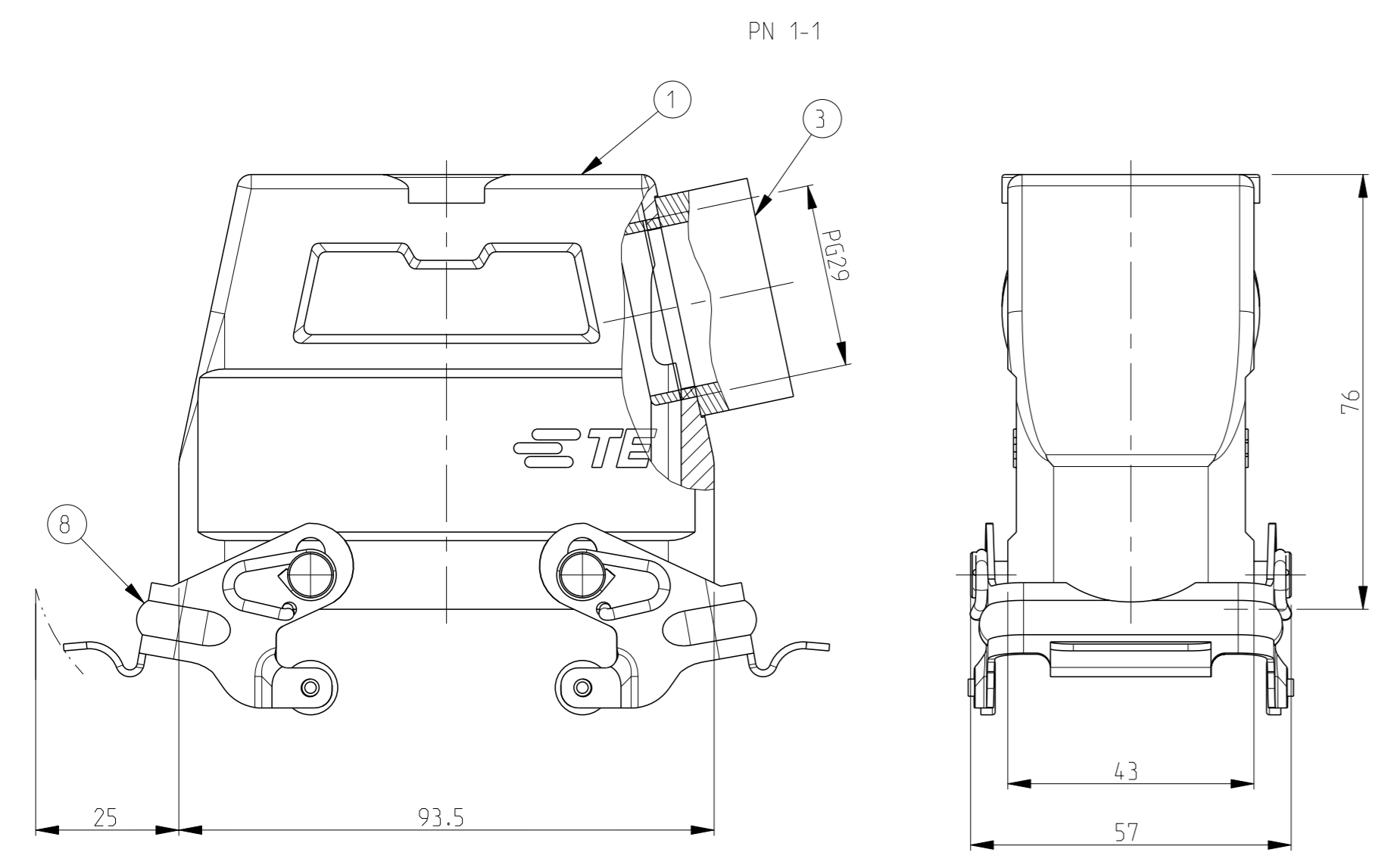
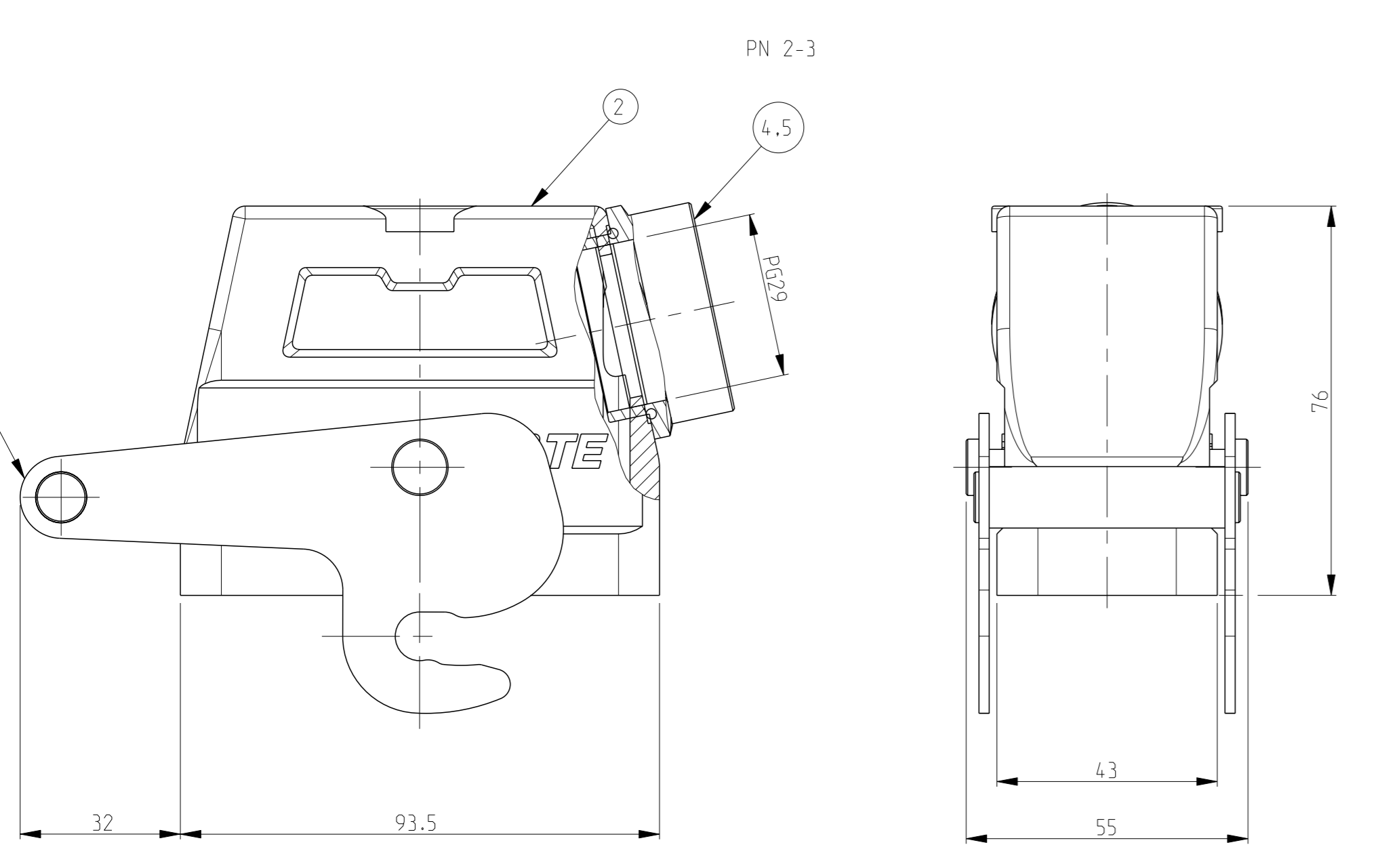
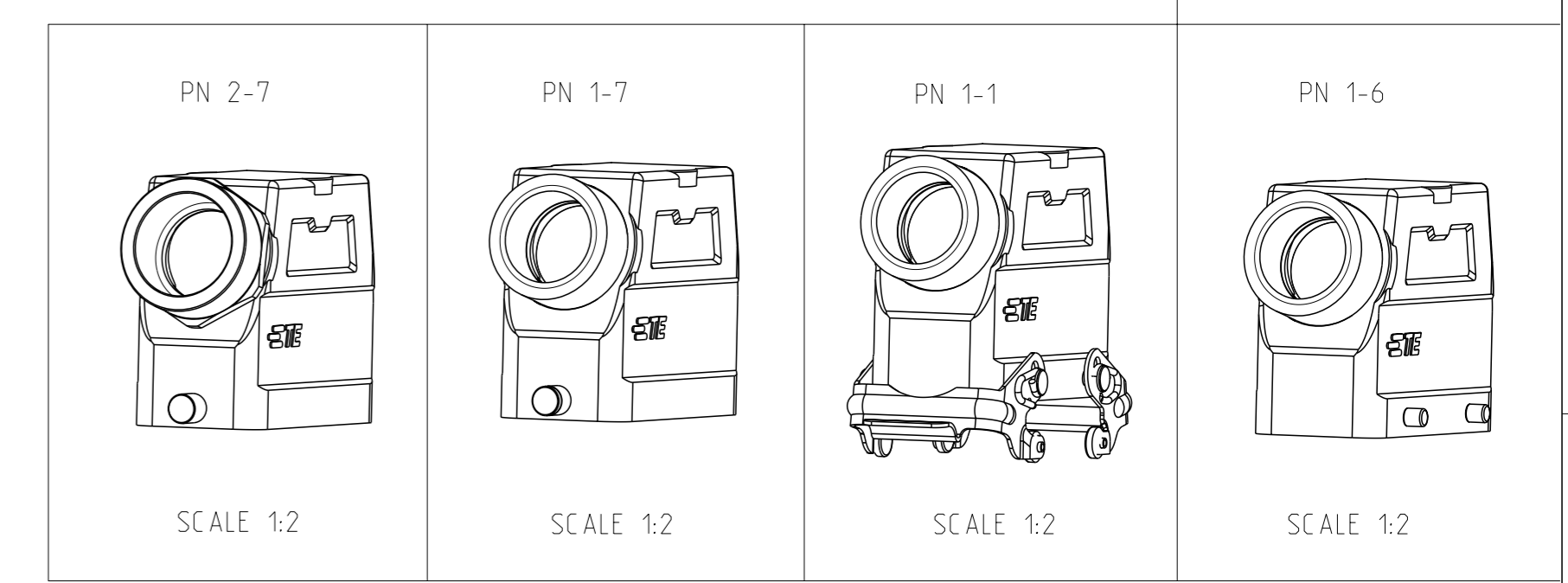
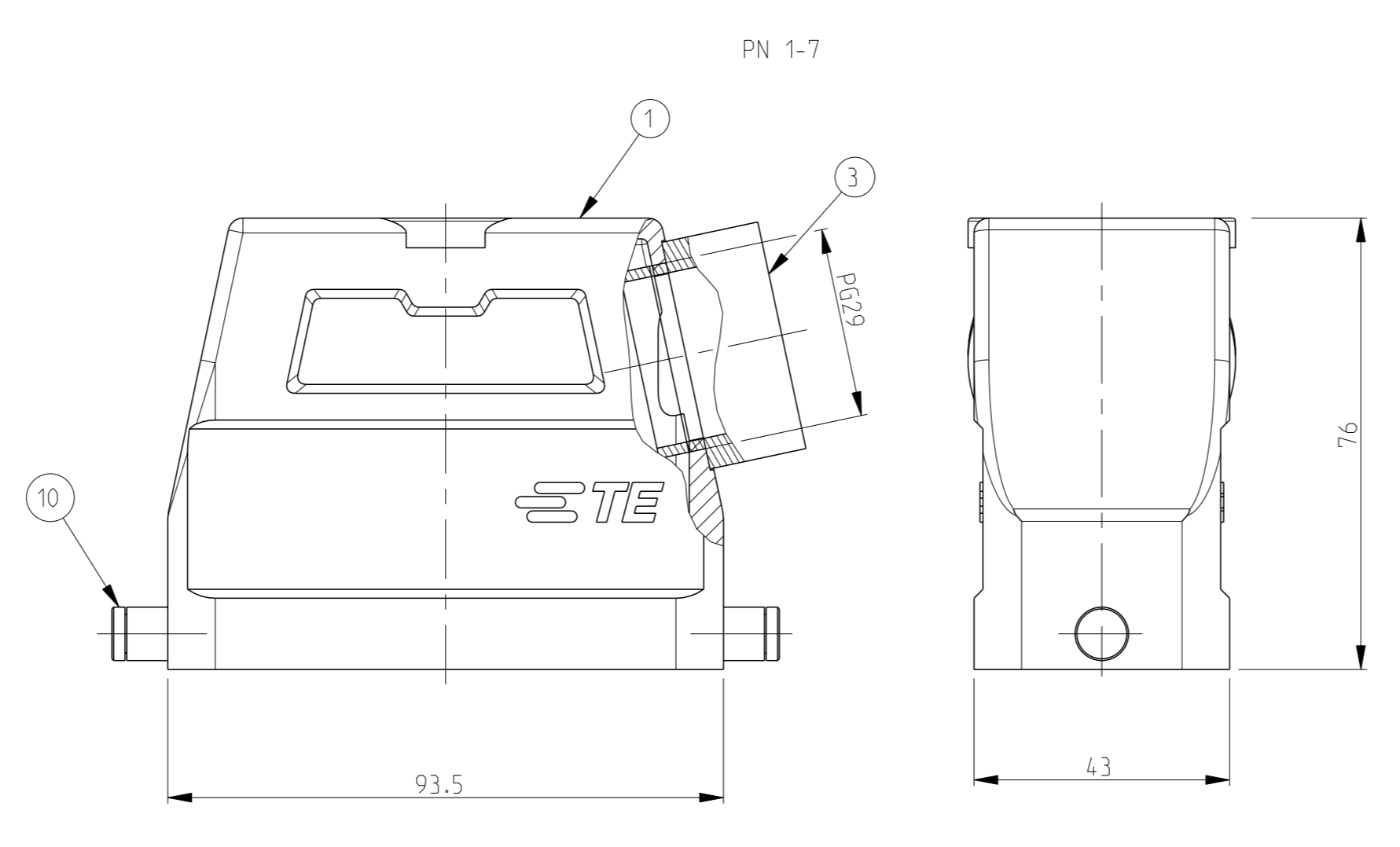
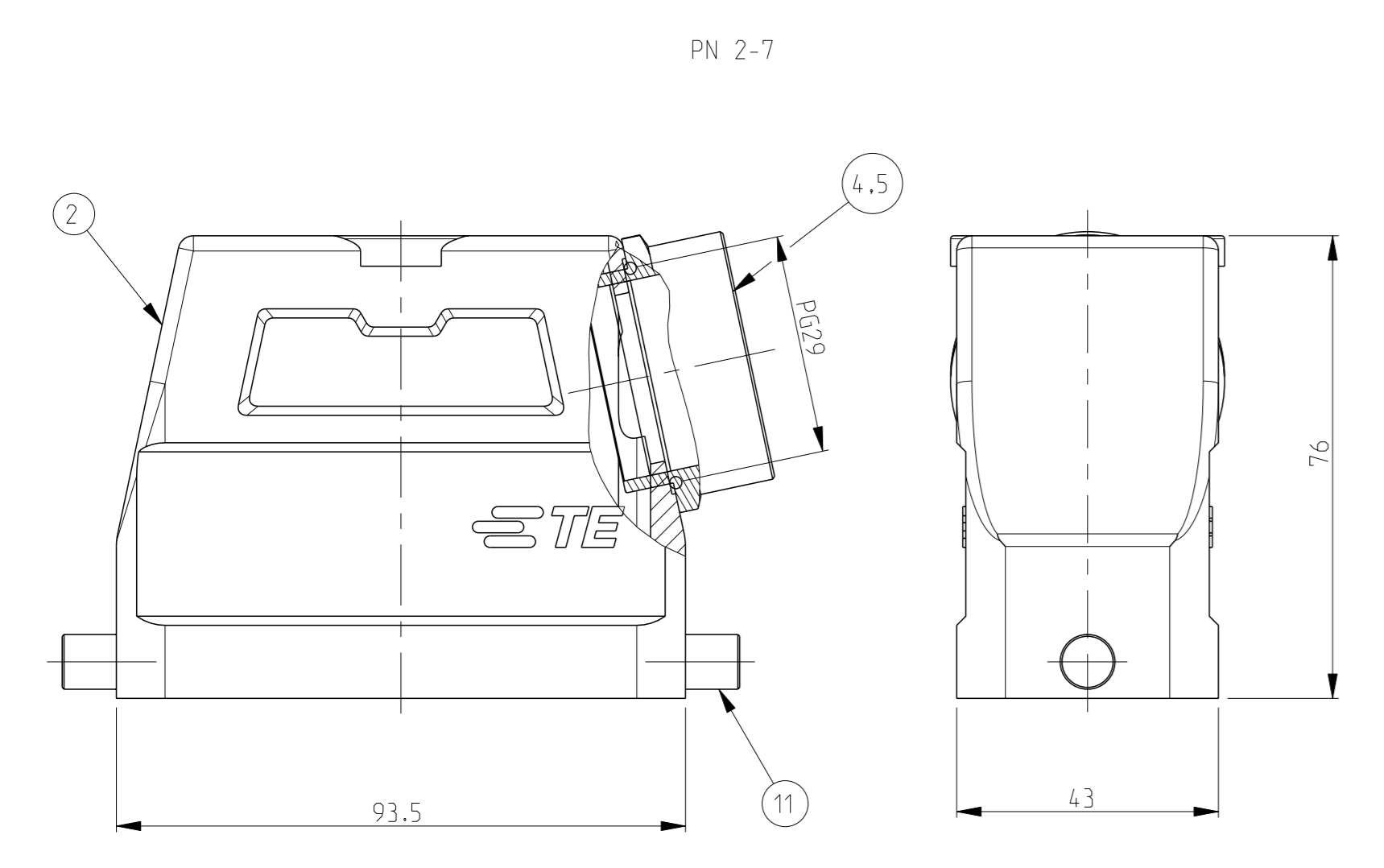
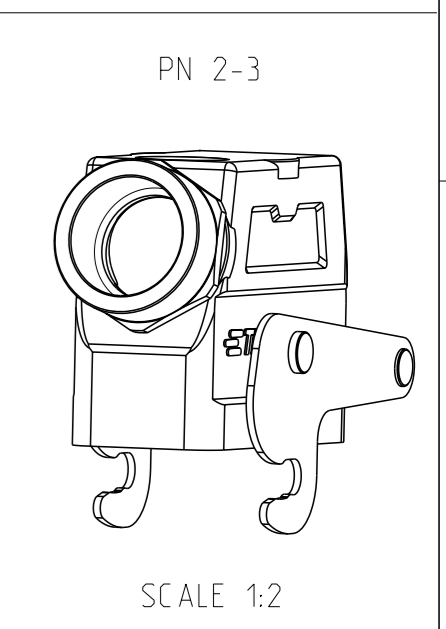

QTY	DESCRIPTION	MATERIAL	SURFACE	COLOR	ITEM NO	REMARKS
13	ZB-Locking clip	V2A	-	-	13	
12	ZB-Locking clip	Steel	Zinc plated	Blue	12	
11	LB-Clip bolt	V2A	-	-	11	
10	LB-Clip bolt	Steel	Zinc plated	Blue	10	
9	VS-Locking clip	V2A	-	-	9	
8	VS-Locking clip	Steel	Zinc plated	Blue	8	
7	VS-Clip bolt	V2A	-	-	7	
6	VS-Clip bolt	Steel	Zinc plated	Blue	6	
5	O-Ring PG29	Neoprene	-	Black	5	
4	6-K1 clip spring right PG29	Brass	Nickel plated	-	4	
3	Connecting piece round PG29	Brass	Nickel plated	-	3	
2	Hood HD40 Pg1.29	Aluminium	Aluminium oxide	Black	2	
1	Hood HD40 Pg1.29	Aluminium	-	Grey	1	
2-3	DESCRIPTION	MATERIAL	SURFACE	COLOR	ITEM NO	REMARKS
1-B	DESCRIPTION					
2-7	DESCRIPTION					
1-7	DESCRIPTION					
2-1	DESCRIPTION					
1-1	DESCRIPTION					
2-6	DESCRIPTION					
1-6	DESCRIPTION					
	HD-40-Sts-1.29-Z					
	HD-K-40-Sts-1.29-Z					
	HD-40-Sts-VS-1.29-Z					
	HDK-40-Sts-VS-1.29-Z					
	HD-40-Sts-GR-1.29-Z					
	HD-K-40-Sts-GR-1.29-Z					
	HD-Z-40-Sts-ZB-1.29-Z					
	HD-K-2-40-Sts-ZB-1.29-Z					

THIS DRAWING IS A CONTROLLED DOCUMENT. OWN: Gr-Stf 11.12.1997. CHK: Kramer 02.06.98. APVD: -

DIMENSIONS: mm. TOLERANCES UNLESS OTHERWISE SPECIFIED: 0 PLG ±, 1 PLG ±, 2 PLG ±, 3 PLG ±, 4 PLG ±, ANGLES FINISH *

MATERIAL: -

PRODUCT SPEC: -
APPLICATION SPEC: -

WEIGHT: -

CUSTOMER DRAWING

NAME: HOOD HD 40 STS1.29.Z
SIZE: A1
CAGE CODE: 00779
DRAWING NO: ©=1102566

RESTRICTED TO: -

SCALE: 1:1 SHEET: 1 OF 1 REV: A7