

### 3.3 VOLT COMMUNICATIONS CLOCK VCXO PLL

### MK2049-34A

#### Description

The MK2049-34A is a VCXO Phased Locked Loop (PLL) based clock synthesizer that accepts multiple input frequencies. With an 8 kHz clock input as a reference, the MK2049-34A generates T1, E1, T3, E3, ISDN, xDSL, and other communications frequencies. This allows for the generation of clocks frequency-locked and phase-locked to an 8 kHz backplane clock, simplifying clock synchronization in communications systems. The MK2409-34 can also accept a T1 or E1 input clock and provide the same output for loop timing. All outputs are frequency locked together and to the input.

This part also has a jitter-attenuated Buffer capability. In this mode, the MK2049-34A is ideal for filtering jitter from 27 MHz video clocks or other clocks with high jitter.

IDT can customize these devices for many other different frequencies.

#### Features

- Packaged in 20-pin SOIC
- Available in Pb (lead) free package
- 3.3 V  $\pm$  5% operation
- Fixed I/O phase relationship on all selections
- Meets the TR62411, ETS300 011, and GR-1244 specification for MTIE, Pull-in/Hold-in Range, Phase Transients, and Jitter Generation for Stratum 3, 4, and 4E
- Accepts multiple inputs: 8 kHz backplane clock, Loop Timing frequencies, or 10 to 36 MHz
- Locks to 8 kHz  $\pm$  100 ppm (External mode)
- Buffer Mode allows jitter attenuation of 10 to 36 MHz input and x1/x0.5 or x2/x4 outputs
- Exact internal ratios enable zero ppm error
- Output clock rates include T1, E1, T3, E3, ISDN, xDSL, and the OC3 submultiples
- See the MK2049-01, -02, and -03 for more selections at 5 V
- Industrial temperature range

**NOTE: EOL for non-green parts to occur on 5/13/10 per PDN U-09-01**

#### Block Diagram

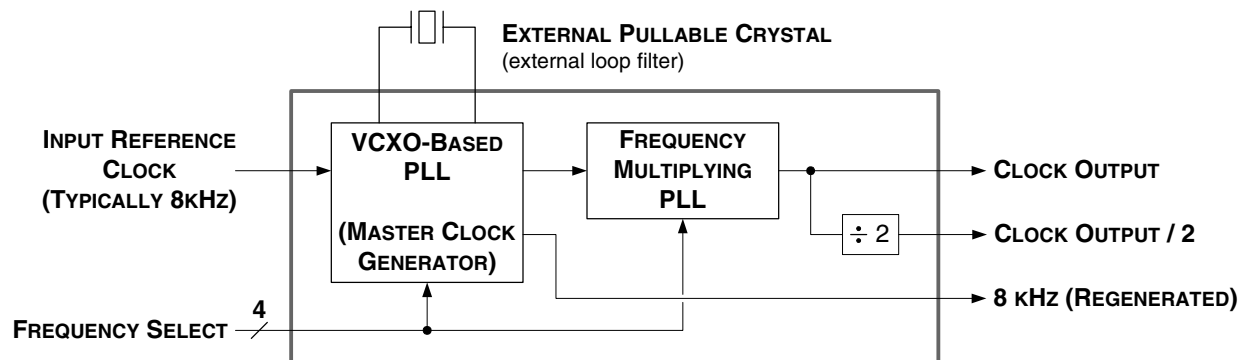

## Pin Assignment

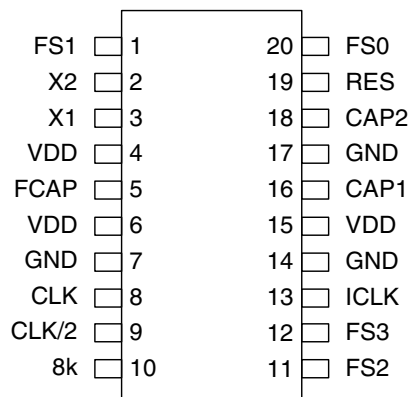

20-pin (300) mil SOIC

## Pin Descriptions

Pin Number	Pin Name	Pin Type	Pin Description
1	FS1	Input	Frequency select 1. Determines CLK input/outputs per table on page 3.
2	X2	XO	Crystal connection. Connect to a MHz crystal as shown in table on page 3.
3	X1	XI	Crystal connection. Connect to a MHz crystal as shown in table on page 3.
4	VDD	Power	Power supply. Connect to +3.3 V.
5	FCAP	—	Filter capacitor. Connect a 1000 pF ceramic capacitor to ground.
6	VDD	Power	Power supply. Connect to +3.3 V.
7	GND	Power	Connect to ground
8	CLK	Output	Clock output determined by status of FS3:0 per tables on page 3.
9	CLK/2	Output	Clock output determined by status of FS3:0 per tables page 3. Always 1/2 of CLK.
10	8k	Output	Recovered 8 kHz clock output.
11	FS2	Input	Frequency select 2. Determines CLK input/outputs per tables on page 3.
12	FS3	Input	Frequency select 3. Determines CLK input/outputs per tables on page 3.
13	ICLK	Input	Input clock connection. Connect to 8 kHz backplane or MHz clock.
14	GND	Power	Connect to ground.
15	VDD	Power	Power Supply. Connect to +3.3 V.
16	CAP1	Loop Filter	Connect the loop filter ceramic capacitors and resistor between this pin and CAP2.
17	GND	Power	Connect to ground.
18	CAP2	Loop	Connect the loop filter ceramic capacitors and resistor between this pin and
19	RES	—	Connect a 10-200kΩ resistor to ground. Contact IDT for recommended value for your application.
20	FS0	Input	Frequency select 0. Determines CLK input/outputs per table on page 3.

## Output Decoding Table - External Mode (MHz)

ICLK	FS3	FS2	FS1	FS0	CLK/2	CLK	8k	Crystal Used (MHz)	N
8 kHz	0	0	0	0	1.544	3.088	8 kHz	12.352	1544
8 kHz	0	0	0	1	2.048	4.096	8 kHz	12.288	1536
8 kHz	0	0	1	0	22.368	44.736	8 kHz	11.184	1398
8 kHz	0	0	1	1	17.184	34.368	8 kHz	11.456	1432
8 kHz	0	1	0	0	19.44	38.88	8 kHz	9.72	1215
8 kHz	0	1	0	1	16.384	32.768	8 kHz	8.192	1024
8 kHz	0	1	1	0	17.664	35.328	8 kHz	17.664	2208
8 kHz	0	1	1	1	18.688	37.376	8 kHz	9.344	1168
8 kHz	1	0	1	0	7.68	15.36	8 kHz	15.36	1920
8 kHz	1	0	1	1	10.752	21.504	8 kHz	10.752	1344
8 kHz	1	1	0	0	10.24	20.48	8 kHz	10.24	1280
8 kHz	1	1	0	1	38.88	77.76	8 kHz	9.72	1215

## Output Decoding Table - Loop Timing Mode (MHz)

ICLK	FS3	FS2	FS1	FS0	CLK/2	CLK	8k	Crystal	N
1.544	1	0	0	0	1.544	3.088	N/A	12.352	24
2.048	1	0	0	1	2.048	4.096	N/A	12.288	18

## Output Decoding Table - Buffer Mode (MHz)

ICLK	FS3	FS2	FS1	FS0	CLK/2	CLK	8k	Crystal	N
19 - 36	1	1	1	0	ICLK/2	ICLK	N/A	ICLK/2	3
10 - 18	1	1	1	1	2*ICLK	4*ICLK	N/A	ICLK	3

0 = connect directly to ground, 1 = connect directly to VDD

Crystal is connected to pins 2 and 3; clock input is applied to pin 13.

## Operating Modes

The MK2049-34A has three operating modes: External, Loop Timing, and Buffer. Although each mode uses an input clock to generate various output clocks, there are important differences in their input and crystal requirements.

### External Mode

The MK2049-34 accepts an external 8 kHz clock and will produce a number of common communication clock frequencies. The 8 kHz input clock does not need to have a 50% duty cycle; a “high” or “on” pulse as narrow as 10 ns is acceptable. In the MK2049-34, the rising edges of CLK and CLK/2 are both aligned with the rising edge of the 8 kHz ICLK; refer to Figure 1 on page 4 for more details.

### Loop Timing Mode

This mode can be used to remove the jitter from standard high-frequency communication clocks. For T1 and E1 inputs, the CLK/2 output will be the same as the input frequency, with CLK at twice the input frequency.

## Buffer Mode

Unlike the other two modes that accept only a single specified input frequency, Buffer Mode will accept a wider range of input clocks. The input jitter is attenuated and the outputs on CLK and CLK/2 also provide the option of getting x1, x2, x4, or 1/2 of the input frequency. For example, this mode can be used to remove the jitter from a 27 MHz clock, generating low-jitter 27 MHz and 13.5 MHz outputs.

## Input and Output Synchronization

As shown in the tables on page 3, the MK2049-34A offers a Zero Delay feature in all selections. There is an internal feedback path between ICLK and the output clocks, providing a fixed phase relationship between the input and output, a requirement in many communication systems.

The rising edge of ICLK will be aligned with the rising edges of CLK and CLK/2 (8 kHz is used in this illustration, but the same is true for the selections in the Loop Timing and Buffer Modes).

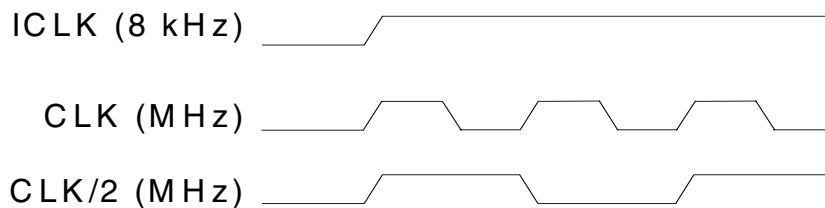

**Figure 1. MK2049-34 Input and Output Clock Waveforms**

## Measuring Zero Delay on the MK2049

The MK2049-34 produces low-jitter output clocks. In addition, this part has a very low bandwidth on the order of a few Hertz. Since most 8 kHz input clocks will have high jitter, this can make measuring the input-to-output skew (zero delay feature) very difficult. The MK2049 is designed to reject the input jitter; when the input and output clocks are both displayed on an oscilloscope, they may *appear* not to be locked because the scope trigger point is constantly changing with the input jitter. In fact, the input and output clocks probably are locked and the MK2049 will have zero delay to the average position of the 8 kHz input clock. In order to see this clearly, a low jitter 8 kHz input clock is necessary. Most lab frequency sources are NOT SUITABLE for this since they have high jitter at low frequencies.

## Frequency Locking to the Input

In all modes, the output clocks are frequency-locked to the input. The outputs will remain at the specified output frequency as long as the combined variation of the input frequency and the crystal does not exceed 100 ppm. For example, if the crystal can vary  $\pm 40$  ppm (initial accuracy + temperature + aging), then the input frequency can vary by up to 60 ppm and still have the output clock remain frequency-locked.

## PC Board Layout

A proper board layout is critical to the successful use of the MK2049-34A. In particular, the CAP1 and CAP2 pins are very sensitive to noise and leakage (CAP2 at pin 18 is the most sensitive). Traces must be as short as possible and the two capacitors and resistor must be mounted next to the device as shown below. The capacitor shown between pins 15 and 17, and the one between pins 4 and 7 are the power supply decoupling capacitors. The high frequency output clocks on pins 8 and 9 should have a series termination of  $33\Omega$  connected close to the pin. Additional improvements will come from keeping all components on the same side of the board, minimizing vias through other signal layers, and routing other signals away from the MK2049. You may also refer to application note MAN05 for additional suggestions on layout of the crystal selection.

The crystal traces should include pads for small capacitors from X1 and X2 to ground. These are used to adjust the stray capacitance of the board to match the crystal load capacitance. The typical telecom reference frequency is accurate to much less than 1 ppm, so the MK2049-34A may lock and run properly even if the board capacitance is not adjusted with these fixed capacitors. However, IDT recommends that the adjustment capacitors be included to minimize the effects of variation in individual crystals, temperature, and aging. The value of these capacitors (typically 0 - 4 pF) is determined once for a given board layout, using the procedure found in application note MAN05.

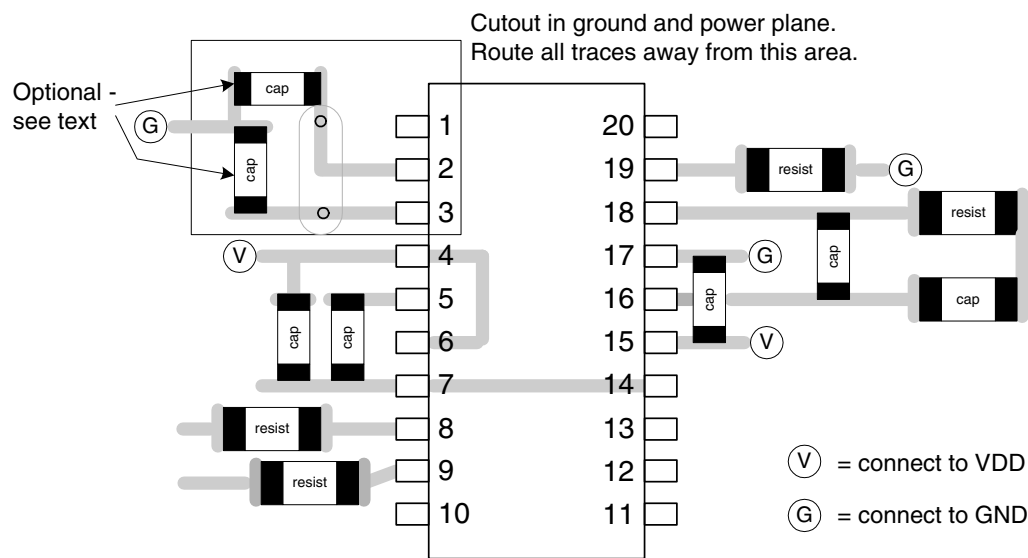

**Figure 2. Typical MK2049-34 Layout**

## External Component Selection

The MK2049-34A requires a minimum number of external components for proper operation. Decoupling capacitors of 0.01 $\mu$ F must be connected between VDD and GND pins close to the chip (especially pins 4 and 7, 15 and 17), and 33 $\Omega$  series terminating resistors should be used on clock outputs with traces longer than one inch (assuming 50 $\Omega$  traces). The selection of additional external components is described in the following sections.

## Loop Filter

Information on how to configure the external loop filter, connected between pins CAP1 and CAP2, can be found on the IDT web site.

## Crystal Operation

The MK2049-34A operates by phase locking the input signal to a VCXO which consists of the recommended pullable VCXO crystals and the integrated VCXO oscillator circuit on the MK2049-34A. To achieve the best performance and reliability, the layout guidelines shown on the previous page should be closely followed.

The frequency of oscillation of a quartz crystal is determined by its cut and by the load capacitors connected to it. The MK2049-34A has variable load capacitors on-chip which “pull” or change the frequency of the crystal. External stray capacitance must be kept to a minimum to ensure maximum pullability of the crystal. To achieve this, the layout should use short traces between the MK2049-34A and the crystal.

For the VCXO to operate correctly, a pullable crystal must be used. For more information, including a list of approved crystals, please refer to application note MAN05.

## Absolute Maximum Ratings

Stresses above the ratings listed below can cause permanent damage to the MK2049-34A. These ratings, which are standard values for IDT commercially rated parts, are stress ratings only. Functional operation of the device at these or any other conditions above those indicated in the operational sections of the specifications is not implied. Exposure to absolute maximum rating conditions for extended periods can affect product reliability. Electrical parameters are guaranteed only over the recommended operating temperature range.

Item	Rating
Supply Voltage, VDD	7 V
All Inputs and Outputs	-0.5 V to VDD+0.5 V
Ambient Operating Temperature	-40 to +85° C
Storage Temperature	-65 to +150° C
Junction Temperature	175° C
Soldering Temperature	260° C (10 to 20 seconds max.)

## Recommended Operation Conditions

Parameter	Min.	Typ.	Max.	Units
Ambient Operating Temperature	-40		+85	°C
Power Supply Voltage (measured in respect to GND)	+3.15	+3.3	+3.45	V

## DC Electrical Characteristics

Unless stated otherwise, **VDD = 3.3 V ±5%**, Ambient Temperature -40 to +85° C

Parameter	Symbol	Conditions	Min.	Typ.	Max.	Units
Operating Voltage	VDD		3.15	3.3	3.45	V
Input High Voltage	V <sub>IH</sub>		2			V
Input Low Voltage	V <sub>IL</sub>				0.8	V
Output High Voltage (CMOS Level)	V <sub>OH</sub>	I <sub>OH</sub> = -4 mA	VDD-0.4			V
Output High Voltage	V <sub>OH</sub>	I <sub>OH</sub> = -8 mA	2.4			V
Output Low Voltage	V <sub>OL</sub>	I <sub>OL</sub> = 8 mA			0.4	V
Operating Supply Current	I <sub>DD</sub>	No Load, VDD=3.3 V		7		mA
Short Circuit Current	I <sub>OS</sub>	Each Output		±50		mA
Input Capacitance	C <sub>IN</sub>	FS3:0		5		pF

## AC Electrical Characteristics

Unless stated otherwise, **VDD = 3.3 V ±5%**, Ambient Temperature -40 to +85° C

Parameter	Symbol	Conditions	Min.	Typ.	Max.	Units
Input Frequency		External Mode, Note 1 ICLK		8		kHz
Input Clock Pulse Width	t <sub>pi</sub>		10			ns
Propagation Delay		ICLK to ICLK		0	6	ns
Output-Output Skew		CLK to CLK/2			150	ps
Output Clock Rise Time	t <sub>OR</sub>	0.8 to 2.0 V			2	ns
Output Fall Time	t <sub>OF</sub>	2.0 to 0.8 V			2	ns
Output Clock Duty Cycle, High Time		at VDD/2, except 8 kHz	40		60	%
Actual mean frequency error versus target		Any clock selection		0	0	ppm

Note 1: For loop timing modes and buffer modes, see tables on page 3 for required input clock frequencies

## Package Outline and Package Dimensions (20-pin SOIC, 300 Mil. Wide Body)

Package dimensions are kept current with JEDEC Publication No. 95

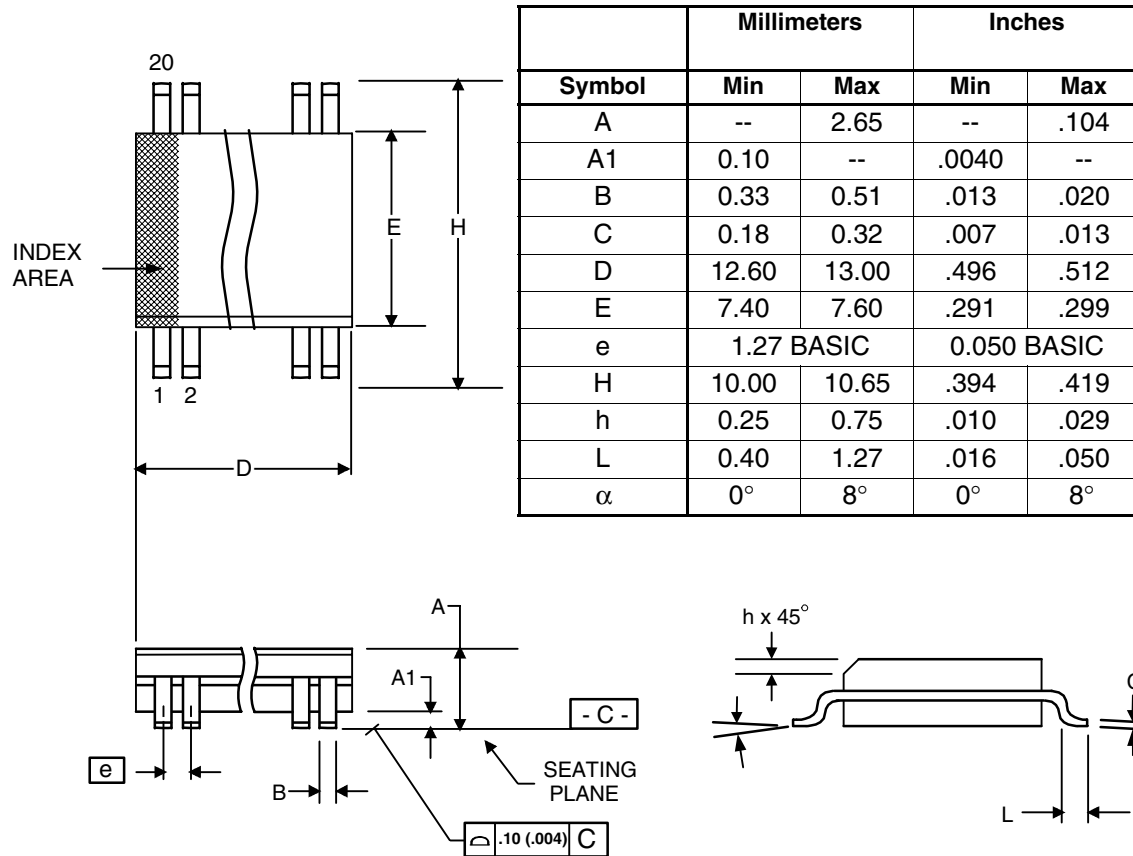

## Ordering Information

Part / Order Number	Marking	Shipping Packaging	Package	Temperature
MK2049-34SAI*	MK2049-34SAI	Tubes	20-pin SOIC	-40 to +85° C
MK2049-34SAITR*	MK2049-34SAI	Tape and Reel	20-pin SOIC	-40 to +85° C
MK2049-34SAILF	MK2049-34SAILF	Tubes	20-pin SOIC	-40 to +85° C
MK2049-34SAILFTR	MK2049-34SAILF	Tape and Reel	20-pin SOIC	-40 to +85° C

\*NOTE: EOL for non-green parts to occur on 5/13/10 per PDN U-09-01

Parts that are ordered with a "LF" suffix to the part number are the Pb-Free configuration and are RoHS compliant.

While the information presented herein has been checked for both accuracy and reliability, Integrated Device Technology (IDT) assumes no responsibility for either its use or for the infringement of any patents or other rights of third parties, which would result from its use. No other circuits, patents, or licenses are implied. This product is intended for use in normal commercial applications. Any other applications such as those requiring extended temperature range, high reliability, or other extraordinary environmental requirements are not recommended without additional processing by IDT. IDT reserves the right to change any circuitry or specifications without notice. IDT does not authorize or warrant any IDT product for use in life support devices or critical medical instruments.



Innovate with IDT and accelerate your future networks. Contact:

**www.IDT.com**

**For Sales**

800-345-7015  
408-284-8200  
Fax: 408-284-2775

**For Tech Support**

[www.idt.com/go/clockhelp](http://www.idt.com/go/clockhelp)

---

**Corporate Headquarters**

Integrated Device Technology, Inc.  
[www.idt.com](http://www.idt.com)



[www.IDT.com](http://www.IDT.com)