



# **GD25WD40C/20C**

# **DATASHEET**

**CONTENTS**

<b>1. FEATURES</b> .....	<b>4</b>
<b>2. GENERAL DESCRIPTION</b> .....	<b>5</b>
<b>3. MEMORY ORGANIZATION</b> .....	<b>8</b>
<b>4. DEVICE OPERATION</b> .....	<b>10</b>
<b>5. DATA PROTECTION</b> .....	<b>11</b>
<b>6. STATUS REGISTER</b> .....	<b>12</b>
<b>7. COMMANDS DESCRIPTION</b> .....	<b>13</b>
7.1. WRITE ENABLE (WREN) (06H) .....	15
7.2. WRITE DISABLE (WRDI) (04H).....	15
7.3. READ STATUS REGISTER (RDSR) (05H).....	16
7.4. WRITE STATUS REGISTER (WRSR) (01H) .....	16
7.5. READ DATA BYTES (READ) (03H) .....	17
7.6. READ DATA BYTES AT HIGHER SPEED (FAST READ) (0BH) .....	17
7.7. DUAL OUTPUT FAST READ (3BH).....	18
7.8. PAGE PROGRAM (PP) (02H).....	18
7.9. SECTOR ERASE (SE) (20H) .....	19
7.10. 32KB BLOCK ERASE (BE) (52H) .....	20
7.11. 64KB BLOCK ERASE (BE) (D8H) .....	20
7.12. CHIP ERASE (CE) (60/C7H).....	21
7.13. DEEP POWER-DOWN (DP) (B9H).....	22
7.14. RELEASE FROM DEEP POWER-DOWN / READ DEVICE ID (ABH) .....	22
7.15. READ MANUFACTURE ID/ DEVICE ID (REMS) (90H) .....	23
7.16. READ IDENTIFICATION (RDID) (9FH) .....	25
<b>8. ELECTRICAL CHARACTERISTICS</b> .....	<b>26</b>
8.1. POWER-ON TIMING .....	26
8.2. INITIAL DELIVERY STATE .....	26
8.3. ABSOLUTE MAXIMUM RATINGS.....	26
8.4. CAPACITANCE MEASUREMENT CONDITIONS .....	27
8.5. DC CHARACTERISTICS.....	28
8.6. AC CHARACTERISTICS .....	31
<b>9. ORDERING INFORMATION</b> .....	<b>37</b>
9.1. VALID PART NUMBERS.....	38
<b>10. PACKAGE INFORMATION</b> .....	<b>40</b>
10.1. PACKAGE SOP8 150MIL .....	40
10.2. PACKAGE SOP8 208MIL .....	41
10.3. PACKAGE TSSOP8 173MIL.....	42
10.4. PACKAGE DIP8 300MIL .....	43



**Uniform Sector  
Standard and Dual Serial Flash**

**GD25WD40C/20C**

---

10.5. PACKAGE USON8 (1.5*1.5MM) .....	44
10.6. PACKAGE USON8 (3*2MM, THICKNESS 0.45MM) .....	45
10.7. PACKAGE WLCSP .....	46
<b>11. REVISION HISTORY.....</b>	<b>47</b>

## 1. FEATURES

- ◆ 4M/2M-bit Serial Flash
  - 512K/256K-byte
  - 256 bytes per programmable page
- ◆ Standard, Dual Output
  - Standard SPI: SCLK, CS#, SI, SO, WP#
  - Dual Output: SCLK, CS#, IO0, O1, WP#
- ◆ Clock Frequency
  - 100MHz for fast read on 3.0~3.6V power supply
    - ◆ Dual Output Data Transfer up to 160Mbits/s
  - 70MHz for fast read on 2.1~3.0V power supply
    - ◆ Dual Output Data Transfer up to 120Mbits/s
  - 50MHz for fast read on 1.65~2.1V power supply
    - ◆ Dual Output Data Transfer up to 80Mbits/s
- ◆ Software/Hardware Write Protection
  - Write protect all/portion of memory via software
  - Enable/Disable protection with WP# Pin
- ◆ Minimum 100,000 Program/Erase Cycles
- ◆ Data Retention
  - 20-year data retention typical
- ◆ Fast Program/Erase Speed
  - Page Program time: 1.6ms typical
  - Sector Erase time: 150ms typical
  - Block Erase time: 0.5/0.8s typical
  - Chip Erase time: 6/3s typical
- ◆ Flexible Architecture
  - Uniform Sector of 4K-byte
  - Uniform Block of 32/64K-byte
- ◆ Low Power Consumption
  - 0.1uA typical standby current
  - 0.1uA typical power down current
- ◆ Single Power Supply Voltage
  - Full voltage range: 1.65~3.6V
- ◆ Package option
  - SOP8 150mil
  - SOP8 208mil
  - TSSOP8 173mil
  - DIP8 300mil
  - USON8 1.5\*1.5mm
  - USON8 3\*2mm
  - WLCSP

## 2. GENERAL DESCRIPTION

The GD25WD40C/20C (4M/2M-bit) Serial flash supports the standard Serial Peripheral Interface (SPI), and supports the Dual Output: Serial Clock, Chip Select, Serial Data I/O0 (SI), O1 (SO). The Dual Output data is transferred with maximum speed of 160Mbits/s.

### CONNECTION DIAGRAM

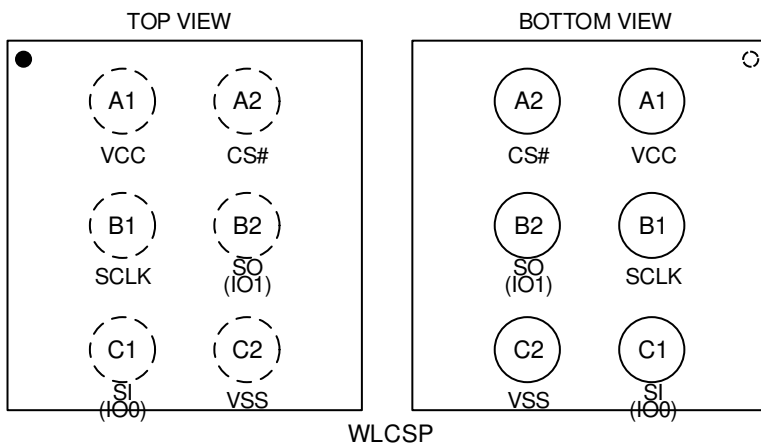
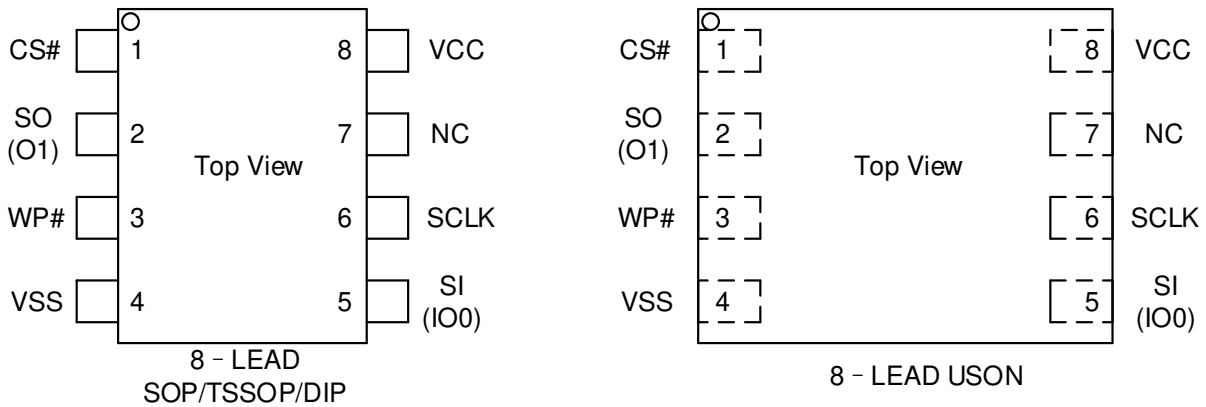

### PIN DESCRIPTION

Table 1. Pin Description for SOP/TSSOP/DIP/USON package

Pin Name	I/O	Description
CS#	I	Chip Select Input
SO (O1)	O	Data Output (Data Output 1)
WP#	I	Write Protect Input
VSS		Ground
SI (IO0)	I/O	Data Input (Data Input Output 0)
SCLK	I	Serial Clock Input
NC		No Connection
VCC		Power Supply

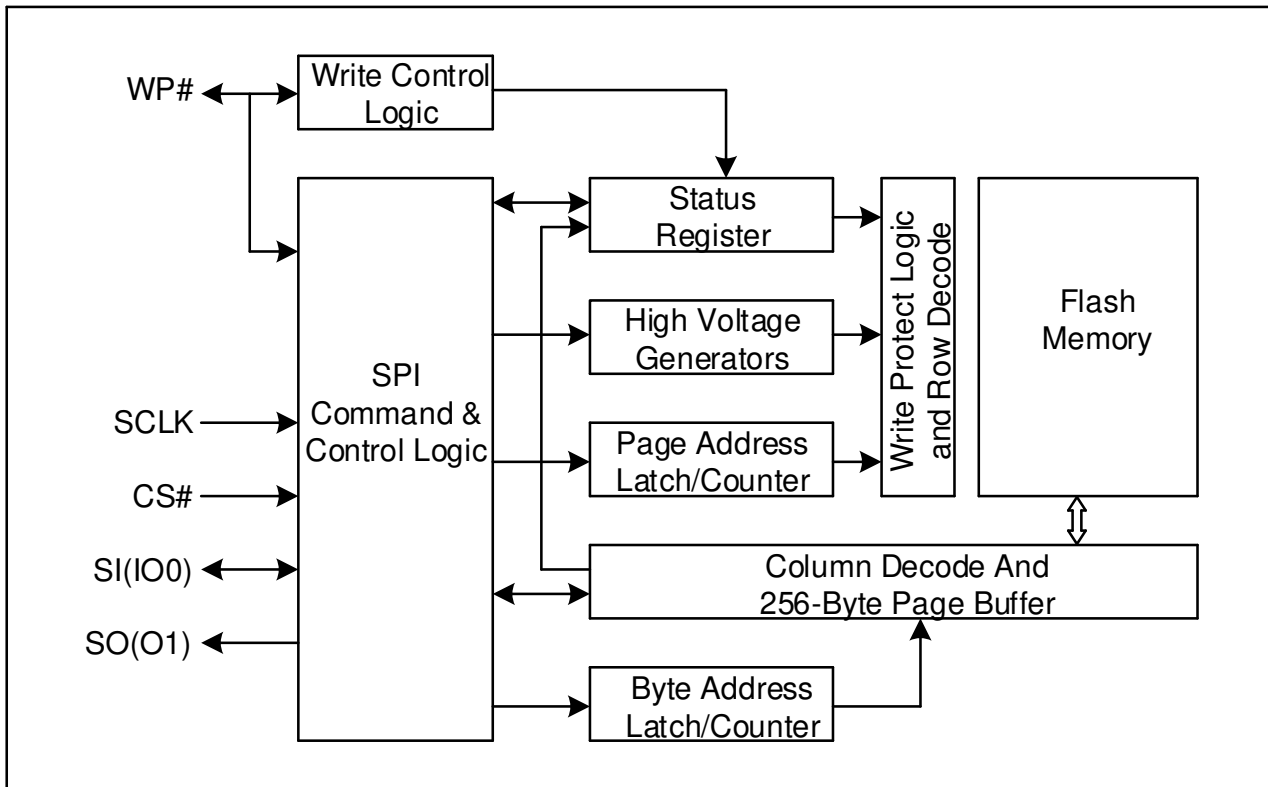

**Table 2. Pin Description for WLCSP package**

<b>Pin Name</b>	<b>Ball Name</b>	<b>I/O</b>	<b>Description</b>
<b>CS#</b>	<b>A2</b>	<b>I</b>	Chip Select Input
<b>SO (IO1)</b>	<b>B2</b>	<b>I/O</b>	Data Output (Data Input Output 1)
<b>VSS</b>	<b>C2</b>		Ground
<b>SI (IO0)</b>	<b>C1</b>	<b>I/O</b>	Data Input (Data Input Output 0)
<b>SCLK</b>	<b>B1</b>	<b>I</b>	Serial Clock Input
<b>VCC</b>	<b>A1</b>		Power Supply

Note: CS# must be driven high if chip is not selected. Please don't leave CS# floating any time after power is on.

BLOCK DIAGRAM





### 3. MEMORY ORGANIZATION

#### GD25WD40C

Each device has	Each block has	Each sector has	Each page has	
512K	64/32K	4K	256	bytes
2K	256/128	16	-	pages
128	16/8	-	-	sectors
8/16	-	-	-	blocks

#### GD25WD20C

Each device has	Each block has	Each sector has	Each page has	
256K	64/32K	4K	256	bytes
1K	256/128	16	-	pages
64	16/8	-	-	sectors
4/8	-	-	-	blocks

### UNIFORM BLOCK SECTOR ARCHITECTURE

#### GD25WD40C 64K Bytes Block Sector Architecture

Block	Sector	Address range	
7	127	07F000H	07FFFFH
	.....	.....	.....
	112	070000H	070FFFH
6	111	06F000H	06FFFFH
	.....	.....	.....
	96	060000H	060FFFH
.....	.....	.....	.....
	.....	.....	.....
	.....	.....	.....
.....	.....	.....	.....
	.....	.....	.....
	.....	.....	.....
2	47	02F000H	02FFFFH
	.....	.....	.....
	32	020000H	020FFFH
1	31	01F000H	01FFFFH
	.....	.....	.....
	16	010000H	010FFFH
0	15	00F000H	00FFFFH
	.....	.....	.....
	0	000000H	000FFFH





**GD25WD20C 64K Bytes Block Sector Architecture**

Block	Sector	Address range	
3	63	03F000H	03FFFFH
	.....	.....	.....
	48	030000H	030FFFH
2	47	02F000H	02FFFFH
	.....	.....	.....
	32	020000H	020FFFH
1	31	01F000H	01FFFFH
	.....	.....	.....
	16	010000H	010FFFH
0	15	00F000H	00FFFFH
	.....	.....	.....
	0	000000H	000FFFH

## 4. DEVICE OPERATION

### SPI Mode

#### Standard SPI

The GD25WD40C/20C features a serial peripheral interface on 4 signals bus: Serial Clock (SCLK), Chip Select (CS#), Serial Data Input (SI) and Serial Data Output (SO). Both SPI bus mode 0 and 3 are supported. Input data is latched on the rising edge of SCLK and data shifts out on the falling edge of SCLK.

#### Dual SPI

The GD25WD40C/20C supports Dual Output operation when using the “Dual Output Fast Read” (3BH) commands. These commands allow data to be transferred to or from the device at twice the rate of the standard SPI. When using the Dual Output command the SI and SO pins become bidirectional I/O pins: IO0 and O1.

## 5. DATA PROTECTION

The GD25WD40C/20C provides the following data protection methods:

- ◆ Write Enable (WREN) command: The WREN command is set the Write Enable Latch bit (WEL). The WEL bit will reset to 0 in the following situations:
  - Power-Up
  - Write Disable (WRDI)
  - Write Status Register (WRSR)
  - Page Program (PP)
  - Sector Erase (SE) / Block Erase (BE) / Chip Erase (CE)
- ◆ Software Protection Mode: The Block Protect (BP2, BP1, BP0) bits define the section of the protected memory area which is read-only and unalterable.
- ◆ Hardware Protection Mode: WP# goes low to protect the BP0~BP2 bits and SRP bits.
- ◆ Deep Power-Down Mode: In Deep Power-Down Mode, all commands are ignored except the Release from Deep Power-Down Mode command.
- ◆ Write Inhibit Voltage (VWI): Device would reset automatically when VCC is below a certain threshold VWI.

**Table3(a) GD25WD40C Protected area size**

Status Register Content			Memory Content			
BP2	BP1	BP0	Blocks	Addresses	Density	Portion
0	0	0	NONE	NONE	NONE	NONE
0	0	1	Sector 0 to 125	000000H-07DFFFH	504KB	Lower126/128
0	1	0	Sector 0 to 123	000000H-07BFFFH	496KB	Lower 124/128
0	1	1	Sector 0 to 119	000000H-077FFFH	480KB	Lower 120/128
1	0	0	Sector 0 to 111	000000H-06FFFFH	448KB	Lower 112/128
1	0	1	Sector 0 to 95	000000H-05FFFFH	384KB	Lower 96/128
1	1	0	Sector 0 to 63	000000H-03FFFFH	256KB	Lower 64/128
1	1	1	All	000000H-07FFFFH	512KB	ALL

**Table3(b) GD25WD20C Protected area size**

Status Register Content			Memory Content			
BP2	BP1	BP0	Blocks	Addresses	Density	Portion
0	0	0	NONE	NONE	NONE	NONE
0	0	1	Sector 0 to 61	000000H-03DFFFH	248KB	Lower 62/64
0	1	0	Sector 0 to 59	000000H-03BFFFH	240KB	Lower 60/64
0	1	1	Sector 0 to 55	000000H-037FFFH	224KB	Lower 56/64
1	0	0	Sector 0 to 47	000000H-02FFFFH	192KB	Lower 48/64
1	0	1	Sector 0 to 31	000000H-01FFFFH	128KB	Lower 32/64
1	1	X	All	000000H-03FFFFH	256KB	ALL

## 6. STATUS REGISTER

S7	S6	S5	S4	S3	S2	S1	S0
SRP	Reserved	Reserved	BP2	BP1	BP0	WEL	WIP

The status and control bits of the Status Register are as follows:

### WIP bit.

The Write In Progress (WIP) bit indicates whether the memory is busy in program/erase/write status register progress. When WIP bit is set to 1, it means the device is busy in program/erase/write status register progress. when WIP bit is cleared to 0, it means the device is not in program/erase/write status register progress. The default value of WIP is 0.

### WEL bit.

The Write Enable Latch (WEL) bit indicates the status of the internal Write Enable Latch. When set to 1 the internal Write Enable Latch is set, when set to 0 the internal Write Enable Latch is reset and no Write Status Register, Program or Erase command is accepted. The default value of WEL is 0.

### BP2, BP1, BP0 bits.

The Block Protect (BP2, BP1, BP0) bits are non-volatile. They define the size of the area to be software protected against Program and Erase commands. These bits are written with the Write Status Register (WRSR) command. When the Block Protect (BP2, BP1, BP0) bits are set to 1, the relevant memory area (as defined in Table3).becomes protected against Page Program (PP), Sector Erase (SE) and Block Erase (BE) commands. The Block Protect (BP2, BP1, BP0) bits can be written provided that the Hardware Protected mode has not been set. The Chip Erase (CE) command is executed, if the Block Protect (BP2, BP1, BP0) bits are all 0. The default value of BP2:0 are 0s.

### SRP bit

The Status Register Protect (SRP) bit operates in conjunction with the Write Protect (WP#) signal. The Status Register Write Protect (SRP) bit and Write Protect (WP#) signal set the device to the Hardware Protected mode. When the Status Register Protect (SRP) bit is set to 1, and Write Protect (WP#) is driven Low. In this mode, the non-volatile bits of the Status Register(SRP, BP2, BP1, BP0) become read-only bits and the Write Status Register (WRSR) instruction is not execution. The default value of SRP is 0.

## 7. COMMANDS DESCRIPTION

All commands, addresses and data are shifted in and out of the device by the host system, with the most significant bit first. On the first rising edge of SCLK after CS# is driven low, the one-byte command code must be shifted into the device, with the most significant bit first on SI, and each bit being latched on the rising edges of SCLK.

See Table4, every command sequence starts with a one-byte command code. Depending on the command, this might be followed by address bytes, or data bytes, or dummy bytes. CS# must be driven high after the last bit of the command sequence has been completed.

For the command of Read, Fast Read, Read Status Register or Release from Deep Power-Down, and Read Device ID, the shifted-in command sequence is followed by a data-out sequence. All read instruction can be completed after any bit of the data-out sequence is being shifted out, and then CS# must be driven high to return to deselected status.

For the command of Page Program, Sector Erase, Block Erase, Chip Erase, Write Status Register, Write Enable, Write Disable or Deep Power-Down command, CS# must be driven high exactly at a byte boundary, which means the clock pulse number should be an exact multiple of eight. Otherwise the command is rejected to executed. Especially for Page Program command, if at any time the input end is not a completed byte, nothing will be written into the memory array, neither would WEL bit be reset.

**Table4. Commands**

Command Name	Byte 1	Byte 2	Byte 3	Byte 4	Byte 5	Byte 6	n-Bytes
Write Enable	06H						
Write Disable	04H						
Read Status Register	05H	(S7-S0)					(continuous)
Write Status Register	01H	S7-S0					
Read Data	03H	A23-A16	A15-A8	A7-A0	(D7-D0)	(Next byte)	(continuous)
Fast Read	0BH	A23-A16	A15-A8	A7-A0	dummy	(D7-D0)	(continuous)
Dual Output Fast Read	3BH	A23-A16	A15-A8	A7-A0	dummy	(D7-D0) <sup>(1)</sup>	(continuous)
Page Program	02H	A23-A16	A15-A8	A7-A0	D7-D0	Next byte	
Sector Erase	20H	A23-A16	A15-A8	A7-A0			
Block Erase(32K)	52H	A23-A16	A15-A8	A7-A0			
Block Erase(64K)	D8H	A23-A16	A15-A8	A7-A0			
Chip Erase	C7/60 H						
Deep Power-Down	B9H						
Release From Deep Power-Down, And Read Device ID	ABH	dummy	dummy	dummy	(DID7- DID0)		(continuous)
Release From Deep Power-Down	ABH						
Manufacturer/ Device ID	90H	00H	00H	00H	(MID7- MID0)	(DID7- DID0)	(continuous)
Read Identification	9FH	(MID7- MID0)	(JDID15- JDID8)	(JDID7- JDID0)			(continuous)

NOTE:

1. Dual Output data

IO0 = (D6, D4, D2, D0)

O1 = (D7, D5, D3, D1)



**TABLE OF ID DEFINATION:**

**GD25WD40C**

<b>Operation Code</b>	<b>M7-M0</b>	<b>ID15-ID8</b>	<b>ID7-ID0</b>
9FH	C8	64	13
90H	C8		12
ABH			12

**GD25WD20C**

<b>Operation Code</b>	<b>M7-M0</b>	<b>ID15-ID8</b>	<b>ID7-ID0</b>
9FH	C8	64	12
90H	C8		11
ABH			11

### 7.1. Write Enable (WREN) (06H)

The Write Enable (WREN) command is for setting the Write Enable Latch (WEL) bit to 1. The Write Enable Latch (WEL) bit must be set prior to every Page Program (PP), Sector Erase (SE), Block Erase (BE), Chip Erase (CE) and Write Status Register (WRSR) command.

The Write Enable (WREN) command sequence: CS# goes low → sending the Write Enable command → CS# goes high.

**Figure1. Write Enable Sequence Diagram**

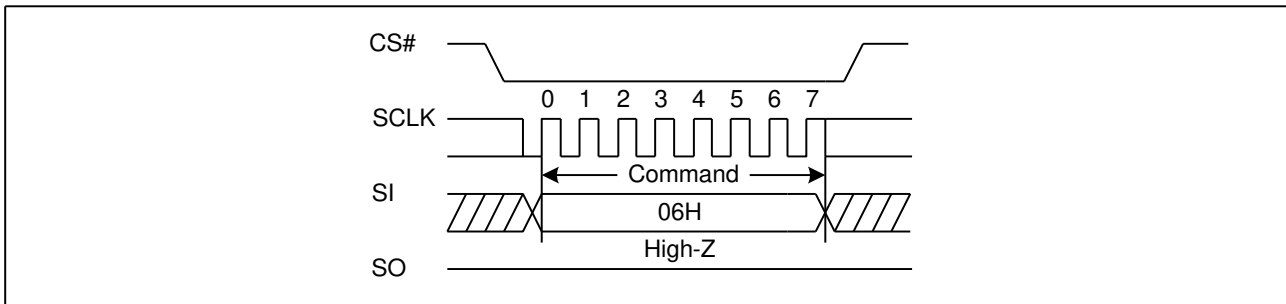

### 7.2. Write Disable (WRDI) (04H)

The Write Disable command is for resetting the Write Enable Latch (WEL) bit to 0. The WEL bit is reset by following condition: Power-up and upon completion of the Write Status Register, Page Program, Sector Erase, Block Erase and Chip Erase commands.

The Write Disable command sequence: CS# goes low → Sending the Write Disable command → CS# goes high.

**Figure2. Write Disable Sequence Diagram**

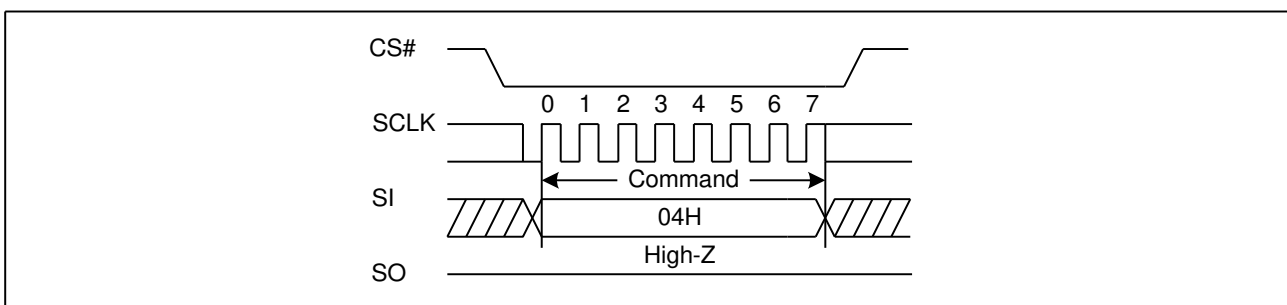

### 7.3. Read Status Register (RDSR) (05H)

The Read Status Register (RDSR) command is for reading the Status Register. The Status Register may be read at any time, even while a Program, Erase or Write Status Register cycle is in progress.

When one of these cycles is in progress, it is recommended to check the Write In Progress (WIP) bit before sending a new command to the device. It is also possible to read the Status Register continuously. For command code "05H", the SO will output Status Register bits S7~S0.

**Figure3. Read Status Register Sequence Diagram**

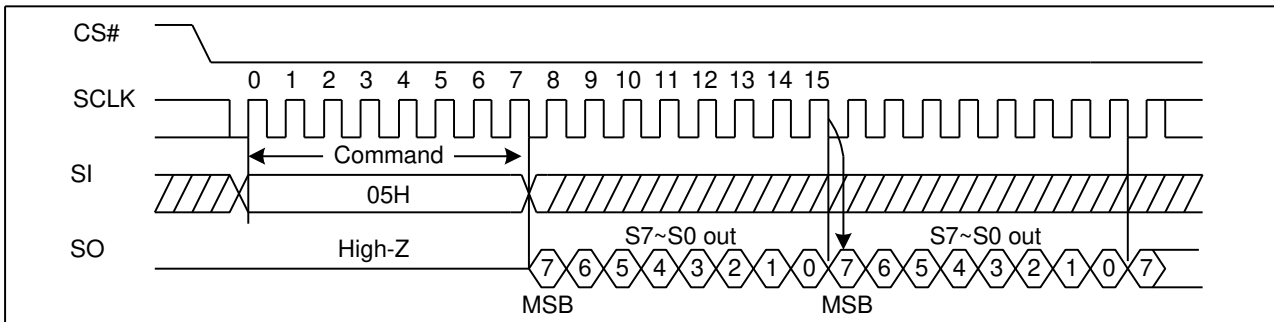

### 7.4. Write Status Register (WRSR) (01H)

The Write Status Register (WRSR) instruction allows new values to be written to the Status Register. A Write Enable (WREN) instruction must be executed previously to set the Write Enable Latch (WEL) bit, before it can be accepted.

The Write Status Register (WRSR) instruction is entered by driving Chip Select (CS#) Low, followed by the instruction code and the data byte on Serial Data Input (DI).

The Write Status Register (WRSR) instruction has no effect on S6, S5, S1 and S0 of the Status Register. S6 and S5 are always read as 0. Chip Select (CS#) must be driven High after the eighth bit of the data byte has been latched in. Otherwise, the Write Status Register (WRSR) instruction is not executed. As soon as Chip Select (CS#) is driven High, the self-timed Write Status Register cycle (the duration is  $t_W$ ) is initiated. While the Write Status Register cycle is in progress, reading Status Register to check the Write In Progress (WIP) bit is achievable.

The Write In Progress (WIP) bit is 1 during the self-timed Write Status Register cycle, and turn to 0 on the completion of the Write Status Register. When the cycle is completed, the Write Enable Latch (WEL) is reset to 0.

The Write Status Register (WRSR) instruction allows the user to change the values of the Block Protect (BP2, BP1, BP0) bits, which are utilized to define the size of the read-only area.

The Write Status Register (WRSR) instruction also allows the user to set or reset the Status Register Protect (SRP) bit in accordance with the Write Protect (WP#) signal, by setting which the device can enter into Hardware Protected Mode. The Write Status Register (WRSR) instruction is not executed once enter into the Hardware Protected Mode.



Figure4. Write Status Register Sequence Diagram

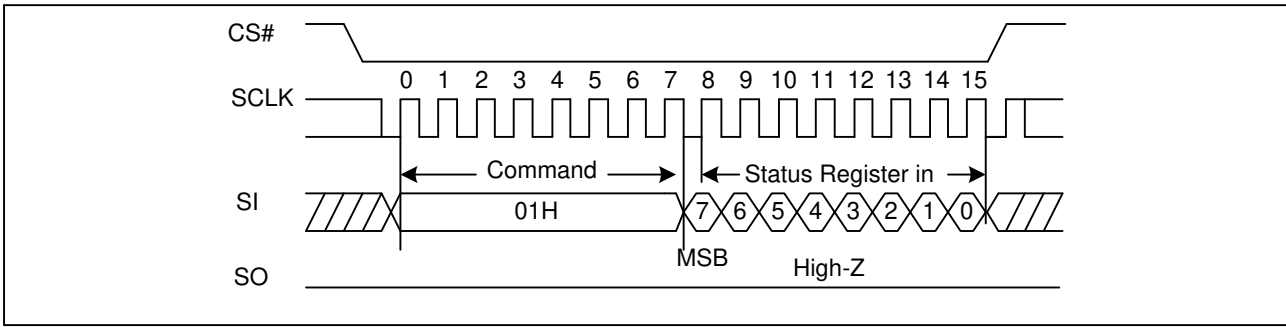

### 7.5. Read Data Bytes (READ) (03H)

The Read Data Bytes (READ) command is followed by a 3-byte address (A23-A0), and each bit being latched-in on the rising edge of SCLK. Then the memory content, at that address, is shifted out on SO, and each bit being shifted out, at a Max frequency  $f_R$ , on the falling edge of SCLK. The first byte addressed can be at any location. The address is automatically incremented to the next higher address after each byte of data is shifted out. The whole memory can, therefore, be read with a single Read Data Bytes (READ) command. Any Read Data Bytes (READ) command, while an Erase, Program or Write cycle is in progress, is rejected without having any effects on the cycle that is in progress.

Figure5. Read Data Bytes Sequence Diagram

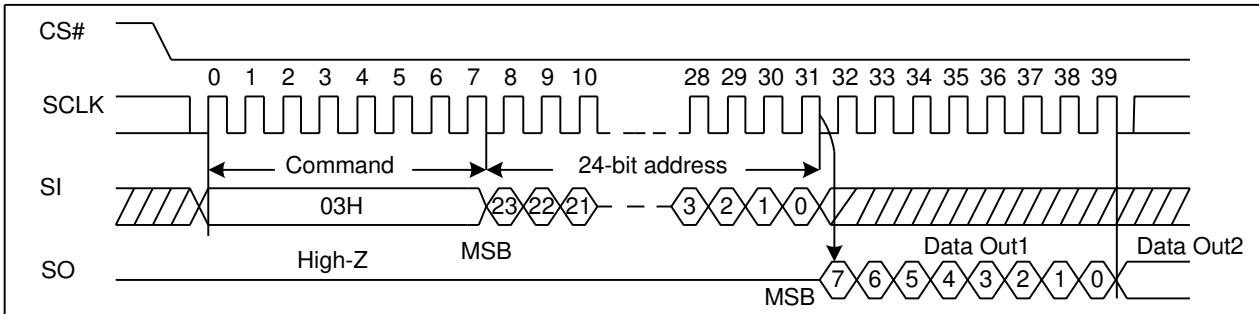

### 7.6. Read Data Bytes At Higher Speed (Fast Read) (0BH)

The Read Data Bytes at Higher Speed (Fast Read) command is for quickly reading data out. It is followed by a 3-byte address (A23-A0) and a dummy byte, and each bit being latched-in on the rising edge of SCLK. Then the memory content, at that address, is shifted out on SO, and each bit being shifted out, at a Max frequency  $f_c$ , on the falling edge of SCLK. The first byte addressed can be at any location. The address is automatically incremented to the next higher address after each byte of data is shifted out.

Figure6. Read Data Bytes at Higher Speed Sequence Diagram

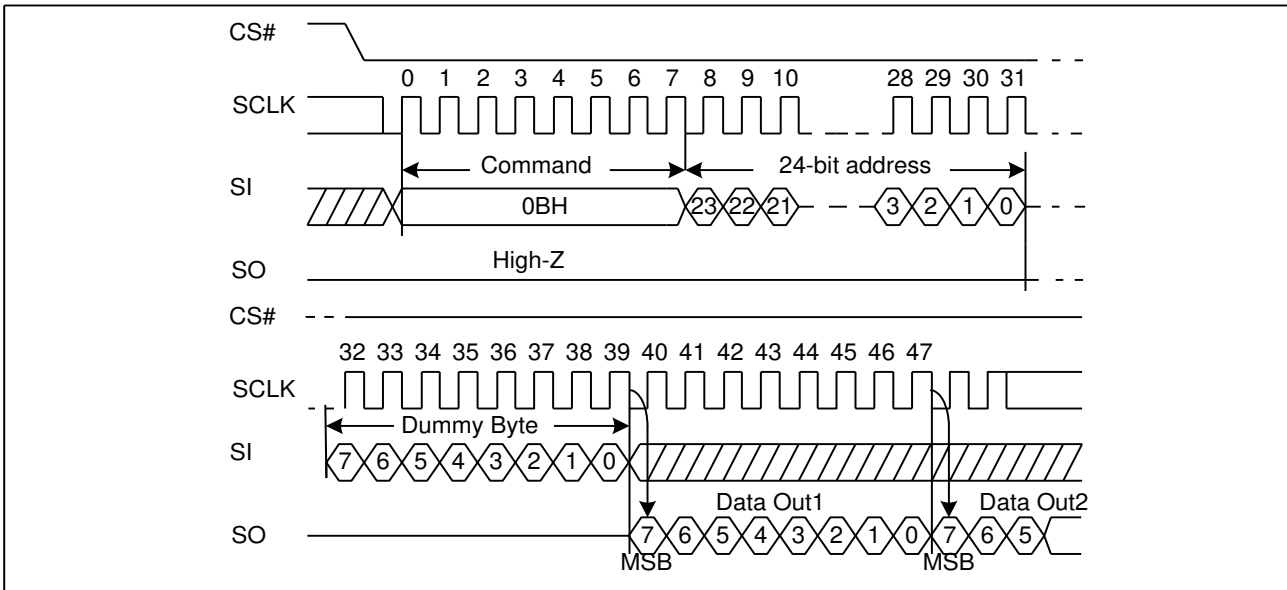

### 7.7. Dual Output Fast Read (3BH)

The Dual Output Fast Read command is followed by 3-byte address (A23-A0) and a dummy byte, and each bit being latched in on the rising edge of SCLK, then the memory contents are shifted out 2-bit per clock cycle from SI and SO. The command sequence is shown in followed Figure7. The first byte addressed can be at any location. The address is automatically incremented to the next higher address after each byte of data is shifted out.

Figure7. Dual Output Fast Read Sequence Diagram

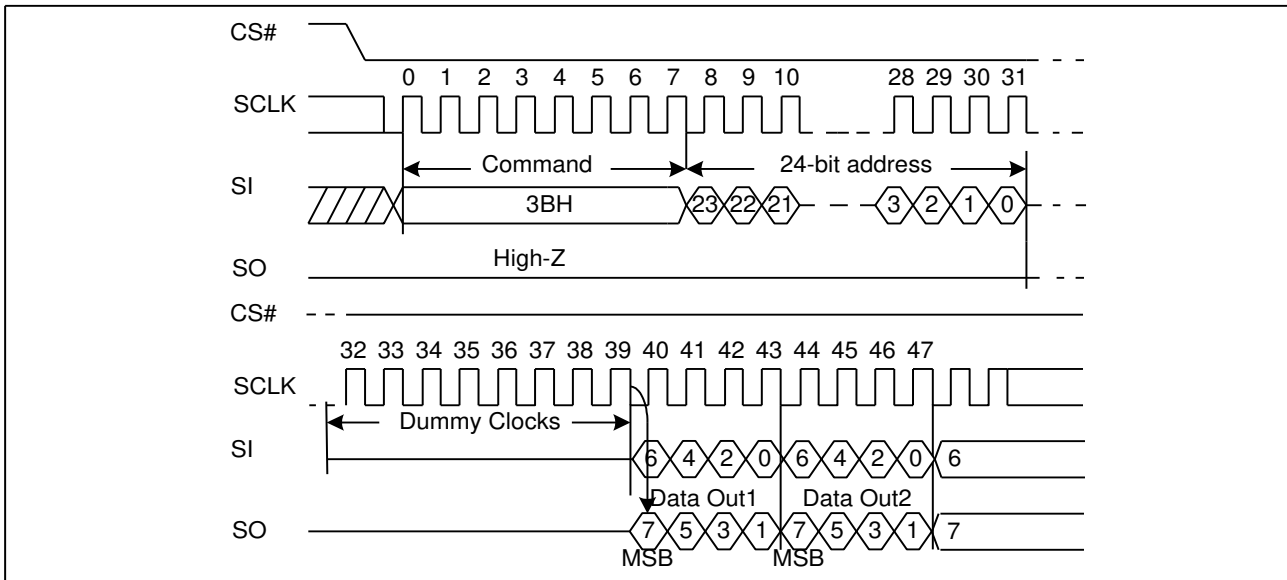

### 7.8. Page Program (PP) (02H)

The Page Program (PP) command is for programming the memory. A Write Enable (WREN) command must previously have been executed to set the Write Enable Latch (WEL) bit before sending the Page Program command.

The Page Program (PP) command is entered by driving CS# Low, followed by the command code, three address bytes and at least one data byte on SI.

If the 8 least significant address bits (A7-A0) are not all zero, all transmitted data that goes beyond the end of the current page are programmed from the start address of the same page (from the address whose 8 least significant bits (A7-A0) are all zero). CS# must be driven low for the entire duration of the sequence.

The Page Program command sequence: CS# goes low → sending Page Program command → 3-byte address on SI → at least 1 byte data on SI → CS# goes high. The command sequence is shown in Figure8.

If more than 256 bytes are sent to the device, previously latched data are discarded and the last 256 data bytes are guaranteed to be programmed correctly within the same page. If less than 256 data bytes are sent to device, they are correctly programmed at the requested addresses without having any effects on the other bytes of the same page. CS# must be driven high after the eighth bit of the last data byte has been latched in; otherwise the Page Program (PP) command is not executed.

As soon as CS# is driven high, the self-timed Page Program cycle (whose duration is  $t_{PP}$ ) is initiated. While the Page Program cycle is in progress, the Status Register may be read to check the value of the Write In Progress (WIP) bit. The Write In Progress (WIP) bit is 1 during the self-timed Page Program cycle, and is 0 when it is completed. At some unspecified time before the cycle is completed, the Write Enable Latch (WEL) bit is reset.

A Page Program (PP) command is not executed when it is applied to a page protected by the Block Protect (BP2, BP1, BP0).

**Figure8. Page Program Sequence Diagram**

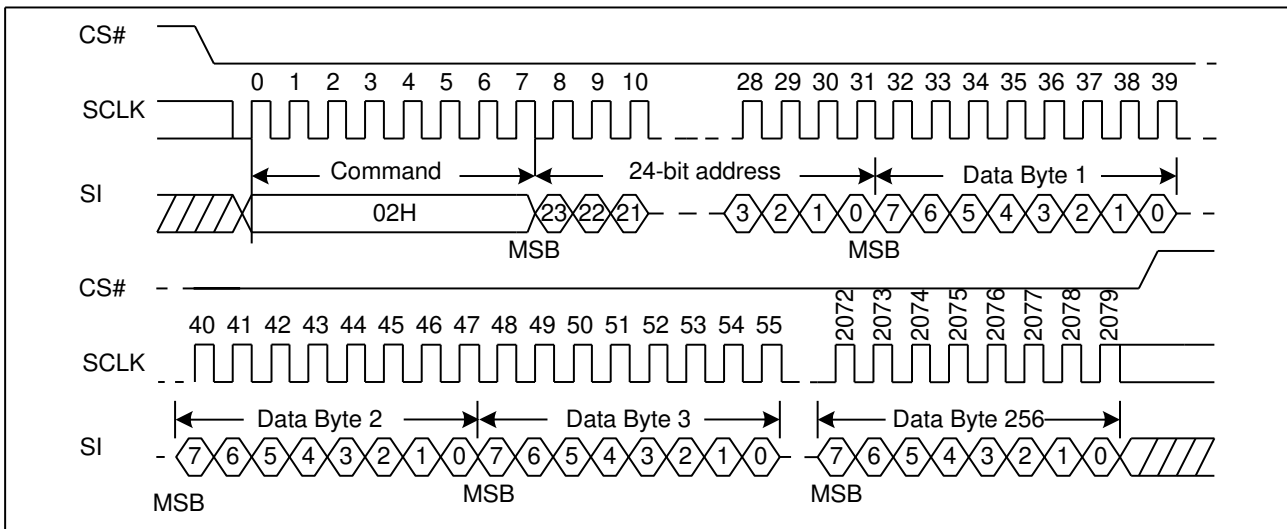

### 7.9. Sector Erase (SE) (20H)

The Sector Erase (SE) command is for erasing the all data of the specific sector. A Write Enable (WREN) command must previously have been executed to set the Write Enable Latch (WEL) bit. The Sector Erase (SE) command is entered by driving CS# low, followed by the command code, and 3-address byte on SI. Any address inside the sector is a valid address for the Sector Erase (SE) command. CS# must be driven low for the entire duration of the sequence.

The Sector Erase command sequence: CS# goes low → sending Sector Erase command → 3-byte address on SI → CS# goes high. The command sequence is shown in Figure9. CS# must be driven high after the eighth bit of the last address byte has been latched in; otherwise the Sector Erase (SE) command is not executed. As soon as CS# is driven high, the self-timed Sector Erase cycle (whose duration is  $t_{SE}$ ) is initiated. While the Sector Erase cycle is in progress, the Status

Register is accessed to check the value of the Write In Progress (WIP) bit. The Write In Progress (WIP) bit is 1 during the self-timed Sector Erase cycle, and becomes 0 when it is completed. At some unspecified time before the cycle is completed, the Write Enable Latch (WEL) bit is reset. A Sector Erase (SE) command applied to a sector which is protected by the Block Protect (BP2, BP1, BP0) bit (see Table3) is not executed.

**Figure9. Sector Erase Sequence Diagram**

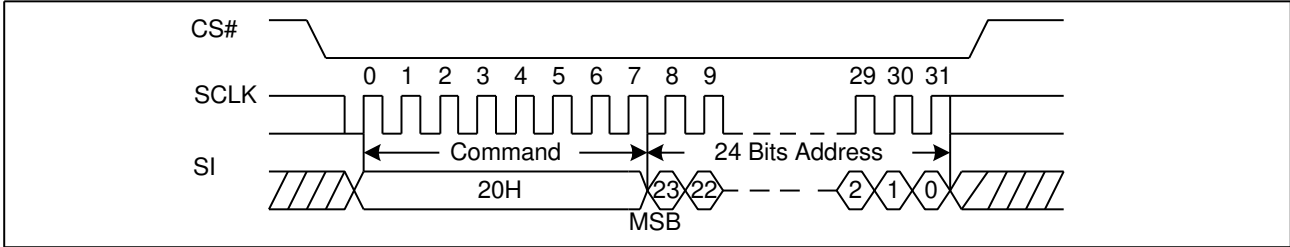

### 7.10. 32KB Block Erase (BE) (52H)

The 32KB Block Erase (BE) command is for erasing the all data of the chosen block. A Write Enable (WREN) command must previously have been executed to set the Write Enable Latch (WEL) bit. The 32KB Block Erase (BE) command is entered by driving CS# low, followed by the command code, and three address bytes on SI. Any address inside the block is a valid address for the 32KB Block Erase (BE) command. CS# must be driven low for the entire duration of the sequence.

The 32KB Block Erase command sequence: CS# goes low → sending 32KB Block Erase command → 3-byte address on SI → CS# goes high. The command sequence is shown in Figure10. CS# must be driven high after the eighth bit of the last address byte has been latched in; otherwise the 32KB Block Erase (BE) command is not executed. As soon as CS# is driven high, the self-timed Block Erase cycle (whose duration is  $t_{BE}$ ) is initiated. While the Block Erase cycle is in progress, the Status Register is accessed to check the value of the Write In Progress (WIP) bit. The Write In Progress (WIP) bit is 1 during the self-timed Block Erase cycle, and becomes 0 when it is completed. At some unspecified time before the cycle is completed, the Write Enable Latch (WEL) bit is reset. A 32KB Block Erase (BE) command applied to a block which is protected by the Block Protect (BP2, BP1, BP0) bits (see Table3) is not executed.

**Figure10. 32KB Block Erase Sequence Diagram**

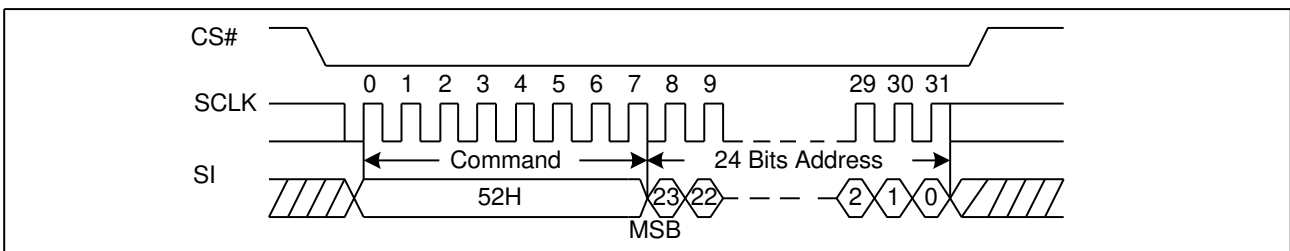

### 7.11. 64KB Block Erase (BE) (D8H)

The 64KB Block Erase (BE) command is for erasing the all data of the chosen block. A Write Enable (WREN) command must previously have been executed to set the Write Enable Latch (WEL) bit. The 64KB Block Erase (BE) command is entered by driving CS# low, followed by the command code, and three address bytes on SI. Any address inside the block is a valid address for the 64KB Block Erase (BE) command. CS# must be driven low for the entire duration of the

sequence.

The 64KB Block Erase command sequence: CS# goes low → sending 64KB Block Erase command → 3-byte address on SI → CS# goes high. The command sequence is shown in Figure11. CS# must be driven high after the eighth bit of the last address byte has been latched in; otherwise the 64KB Block Erase (BE) command is not executed. As soon as CS# is driven high, the self-timed Block Erase cycle (whose duration is  $t_{BE}$ ) is initiated. While the Block Erase cycle is in progress, the Status Register is accessed to check the value of the Write In Progress (WIP) bit. The Write In Progress (WIP) bit is 1 during the self-timed Block Erase cycle, and becomes 0 when it is completed. At some unspecified time before the cycle is completed, the Write Enable Latch (WEL) bit is reset. A 64KB Block Erase (BE) command applied to a block which is protected by the Block Protect (BP2, BP1, BP0) bits (see Table3) is not executed.

**Figure11. 64KB Block Erase Sequence Diagram**

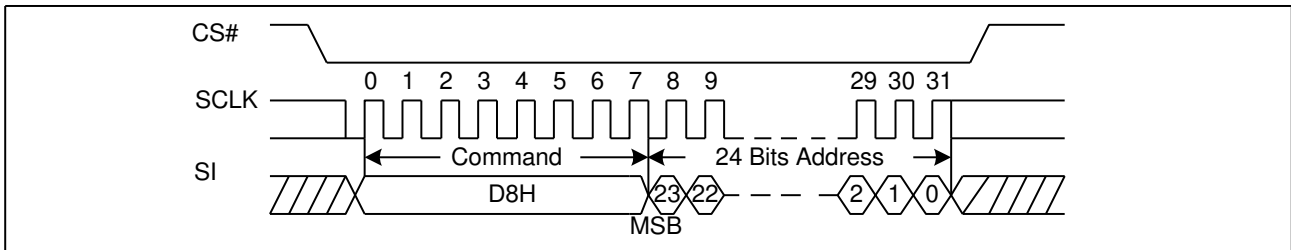

## 7.12. Chip Erase (CE) (60/C7H)

The Chip Erase (CE) command is for erasing the all data of the chip. A Write Enable (WREN) command must previously have been executed to set the Write Enable Latch (WEL) bit. The Chip Erase (CE) command is entered by driving CS# Low, followed by the command code on Serial Data Input (SI). CS# must be driven Low for the entire duration of the sequence.

The Chip Erase command sequence: CS# goes low → sending Chip Erase command → CS# goes high. The command sequence is shown in Figure12. CS# must be driven high after the eighth bit of the command code has been latched in, otherwise the Chip Erase command is not executed. As soon as CS# is driven high, the self-timed Chip Erase cycle (whose duration is  $t_{CE}$ ) is initiated. While the Chip Erase cycle is in progress, the Status Register may be read to check the value of the Write In Progress (WIP) bit. The Write In Progress (WIP) bit is 1 during the self-timed Chip Erase cycle, and is 0 when it is completed. At some unspecified time before the cycle is completed, the Write Enable Latch (WEL) bit is reset. The Chip Erase (CE) command is executed if the Block Protect (BP2, BP1, BP0) bits are all 0. The Chip Erase (CE) command is not executed if any sector is under protection.

**Figure12. Chip Erase Sequence Diagram**

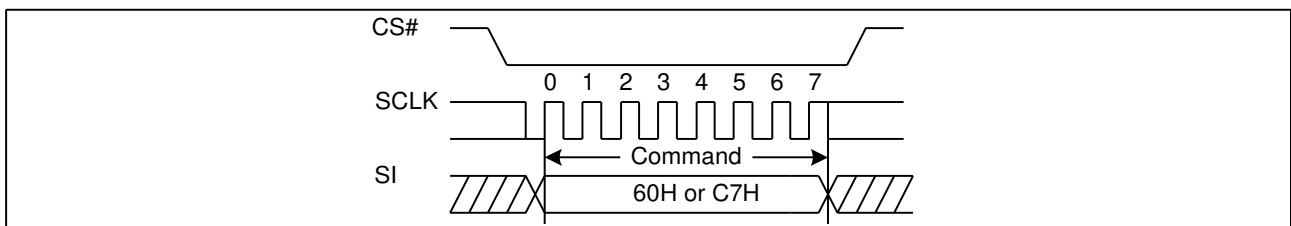

### 7.13. Deep Power-Down (DP) (B9H)

Executing the Deep Power-Down (DP) command is the only way to enter the lowest consumption mode (the Deep Power-Down Mode). Unlike deselecting the device by driving CS# high, or entering into the Standby Mode (if there is no internal cycle currently in progress), the Deep Power-Down Mode provides an extra software protection mechanism while the device is not in active use. The only access to this mode is by executing the Deep Power-Down (DP) command. Since in the Deep Power-Down mode, the device ignores all Write, Program and Erase commands. Once the device is in the Deep Power-Down Mode, all commands are ignored except the Release from Deep Power-Down and Read Device ID (RDI) command. This releases the device from this mode. The Release from Deep Power-Down and Read Device ID (RDI) command also allows the Device ID of the device to be output on SO.

The Deep Power-Down Mode automatically stops at Power-Down, and the device always Power-Up in the Standby Mode. The Deep Power-Down (DP) command is entered by driving CS# low, followed by the command code on SI. CS# must be driven low for the entire duration of the sequence.

The Deep Power-Down command sequence: CS# goes low → sending Deep Power-Down command → CS# goes high. The command sequence is shown in Figure13. CS# must be driven high after the eighth bit of the command code has been latched in; otherwise the Deep Power-Down (DP) command is not executed. As soon as CS# is driven high, it requires a delay of  $t_{DP}$  before the supply current is reduced to  $I_{CC2}$  and the Deep Power-Down Mode is entered. Any Deep Power-Down (DP) command, while an Erase, Program or Write cycle is in progress, is rejected without having any effects on the cycle that is in progress.

**Figure13. Deep Power-Down Sequence Diagram**

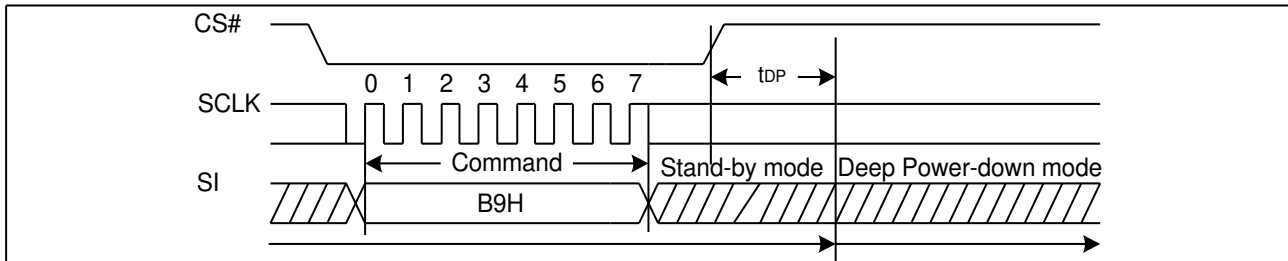

### 7.14. Release from Deep Power-Down / Read Device ID (ABH)

The Release from Power-Down and Read Device ID command is a multi-purpose command, which can be used to release the device from the Power-Down state or obtain the devices electronic identification (ID) number.

When used to release the device from the Power-Down state, the command is issued by driving the CS# pin low, shifting the instruction code “ABH” and driving CS# high as shown in Figure14. Release from Power-Down will take the time duration of  $t_{RES1}$  (See AC Characteristics) before the device will resume normal operation and other command are accepted. The CS# pin must keep high during the  $t_{RES1}$  time duration.

When used only to obtain the Device ID while not in the Power-Down state, the command is initiated by driving the CS# pin low and shifting the instruction code “ABH” followed by 3-dummy byte. The Device ID bits are then shifted out on the falling edge of SCLK with most significant bit (MSB) first as shown in Figure15. The Device ID value for the GD25WD40C/20C is listed in Manufacturer and Device Identification table. The Device ID can be read continuously. The command is completed by driving CS# high.

When used to release the device from the Power-Down state and obtain the Device ID, the command is the same as previously described, and shown in Figure15, except that after CS# is driven high it must remain high for a time duration of  $t_{RES2}$  (See AC Characteristics). After this time duration the device will resume normal operation and other

command will be accepted. If the Release from Power-Down and Read Device ID command is issued while an Erase, Program or Write cycle is in process (when WIP equal 1) the command is ignored and will not have any effects on the current cycle.

**Figure14. Release Power-Down Sequence Diagram**

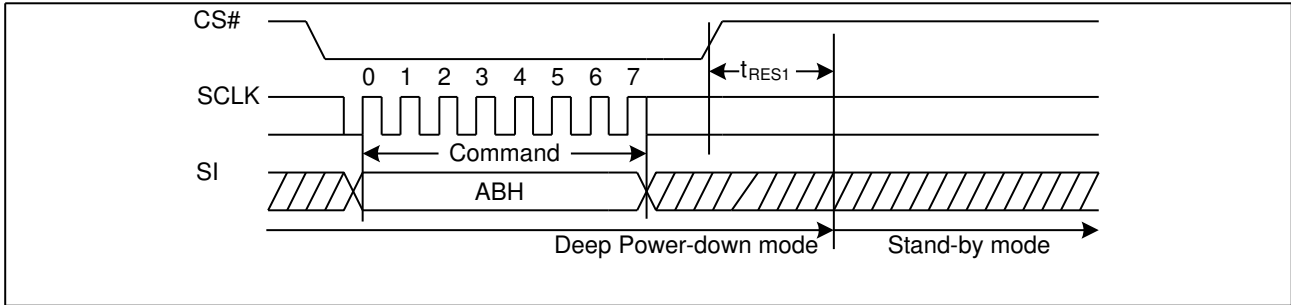

**Figure15. Release Power-Down and Read Device ID Sequence Diagram**

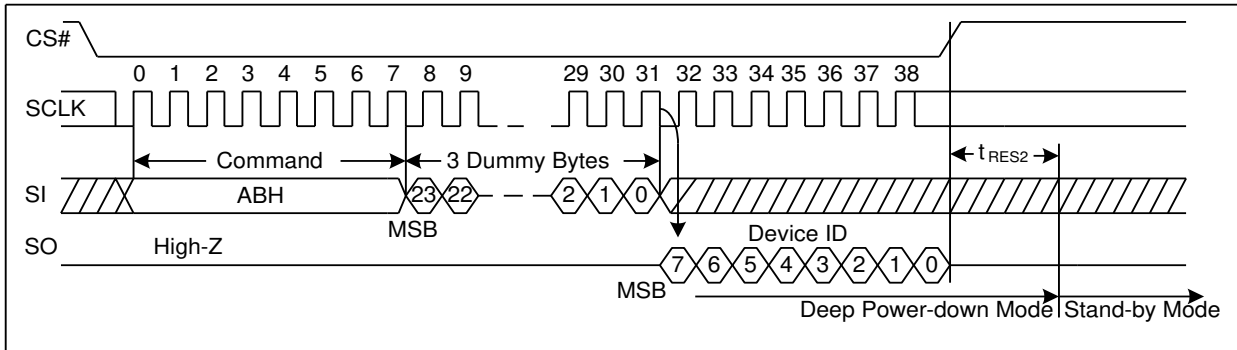

### 7.15. Read Manufacture ID/ Device ID (REMS) (90H)

The Read Manufacturer/Device ID command is an alternative to the Release from Power-Down / Device ID command that provides both the JEDEC assigned Manufacturer ID and the specific Device ID.

The command is initiated by driving the CS# pin low and shifting the command code “90H” followed by a 24-bit address (A23-A0) of 000000H. After that, the Manufacturer ID and the Device ID are shifted out on the falling edge of SCLK with most significant bit (MSB) first as shown in Figure16. If the 24-bit address is initially set to 000001H, the Device ID will be read first.

**Figure16. Read Manufacture ID/ Device ID Sequence Diagram**

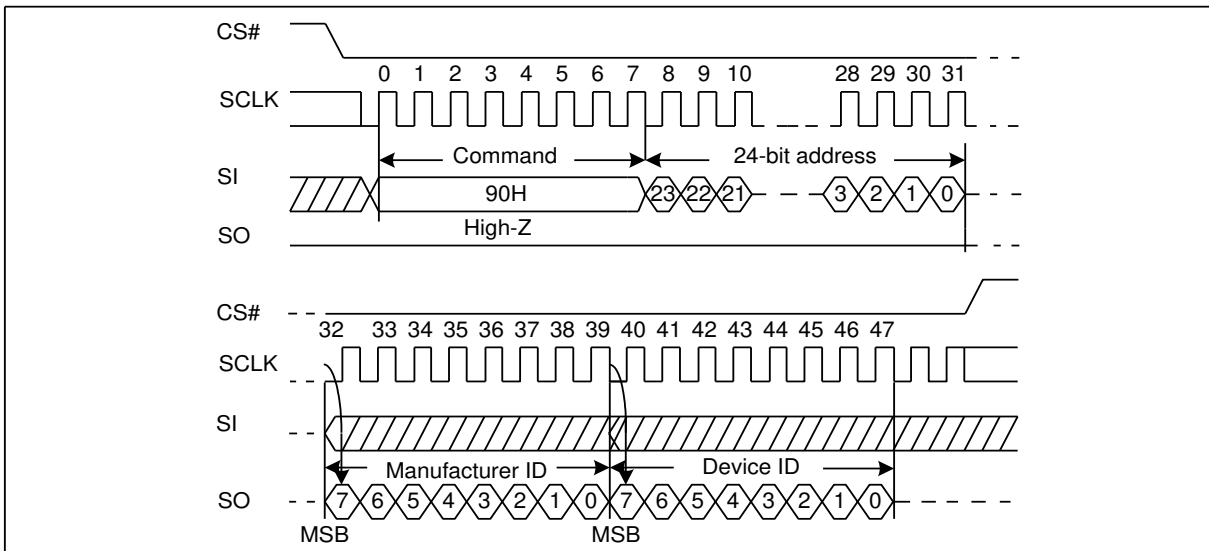



**7.16. Read Identification (RDID) (9FH)**

The Read Identification (RDID) command allows the 8-bit manufacturer identification to be read, followed by two bytes of device identification. The device identification indicates the memory type in the first byte, and the memory capacity of the device in the second byte. Any Read Identification (RDID) command while an Erase or Program cycle is in progress is not decoded, and has no effect on the cycle that is in progress. The Read Identification (RDID) command should not be issued while the device is in Deep Power-Down Mode.

The device is first selected by driving CS# low. Then, the 8-bit command code for the command is shifted in. This is followed by the 24-bit device identification, stored in the memory. Each bit is shifted out on the falling edge of Serial Clock. The command sequence is shown in Figure17. The Read Identification (RDID) command is terminated by driving CS# high at any time during data output. When CS# is driven high, the device is in the Standby Mode. Once in the Standby Mode, the device waits to be selected, so that it can receive, decode and execute commands.

**Figure17. Read Identification ID Sequence Diagram**

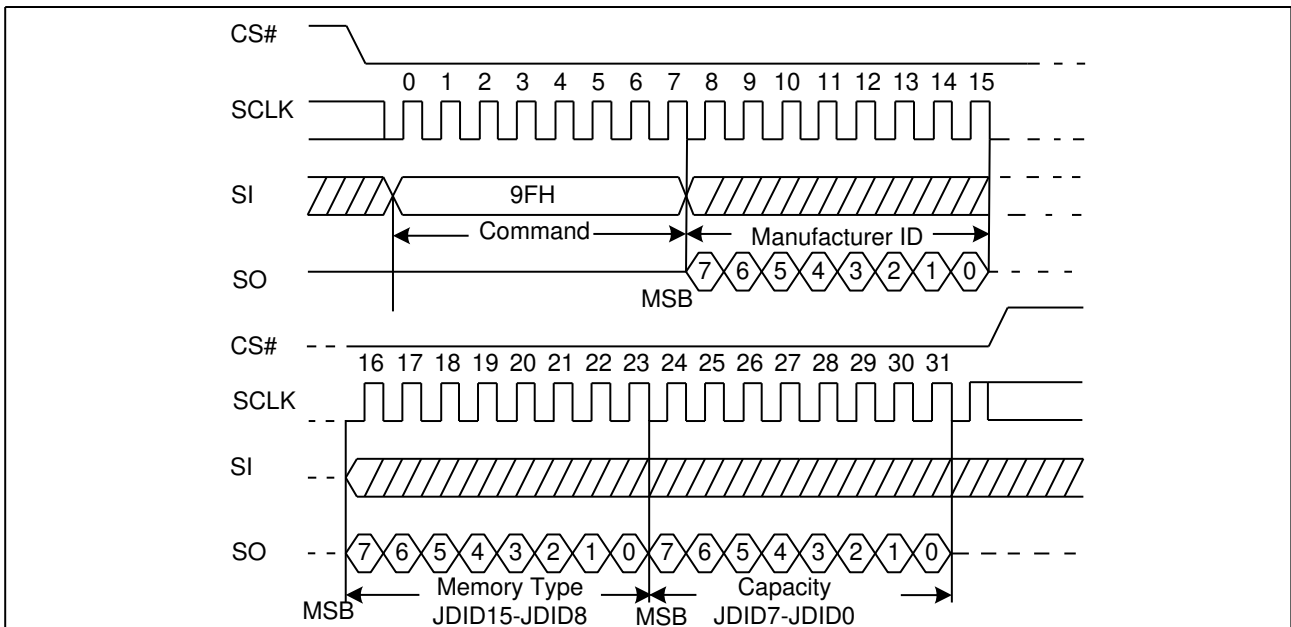

## 8. ELECTRICAL CHARACTERISTICS

### 8.1. POWER-ON TIMING

Figure18. Power-On Timing Sequence Diagram

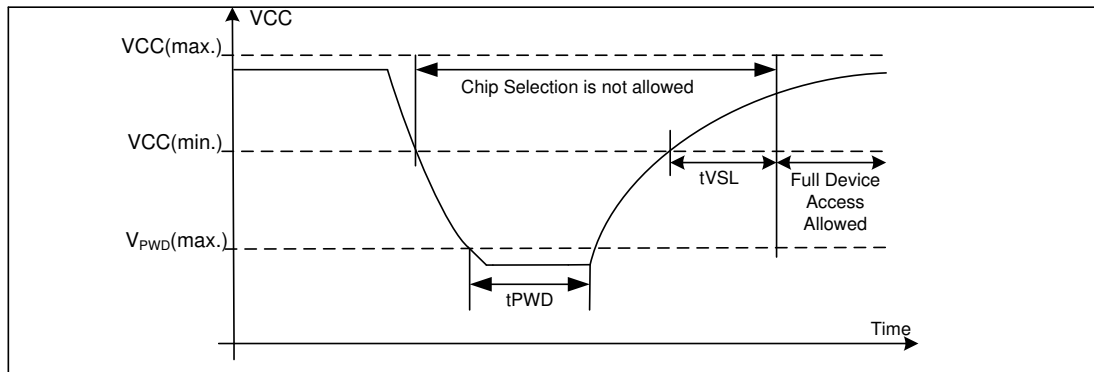

Table 5. Power-Up Timing and Write Inhibit Threshold

Symbol	Parameter	Min.	Max.	Unit
tVSL	VCC (min.) to device operation	0.3		ms
VWI	Write Inhibit Voltage	1	1.55	V
VPWD	VCC voltage needed to below VPWD for ensuring initialization will occur		0.5	V
tPWD	The minimum duration for ensuring initialization will occur	300		us

### 8.2. INITIAL DELIVERY STATE

The device is delivered with the memory array erased: all bits are set to 1 (each byte contains FFH). The Status Register contains 00H (all Status Register bits are 0).

### 8.3. ABSOLUTE MAXIMUM RATINGS

Parameter	Value	Unit
Ambient Operating Temperature	-40 to 85 -40 to 105 -40 to 125	°C
Storage Temperature	-65 to 150	°C
Applied Input/Output Voltage	-0.6 to VCC+0.4	V
Transient Input/Output Voltage (note: overshoot)	-2.0 to VCC+2.0	V
VCC	-0.6 to 4.2	V

Figure19. Maximum Negative/positive Overshoot Diagram

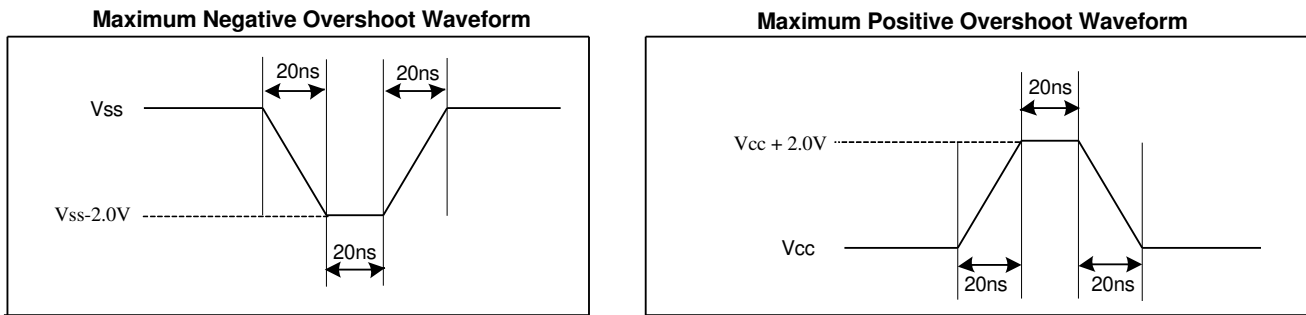

### 8.4. CAPACITANCE MEASUREMENT CONDITIONS

Symbol	Parameter	Min	Typ.	Max	Unit	Conditions
CIN	Input Capacitance			6	pF	VIN=0V
COUT	Output Capacitance			8	pF	VOUT=0V
CL	Load Capacitance	30			pF	
	Input Rise And Fall time			5	ns	
	Input Pulse Voltage	0.1VCC to 0.8VCC			V	
	Input Timing Reference Voltage	0.2VCC to 0.7VCC			V	
	Output Timing Reference Voltage	0.5VCC			V	

Figure 20. Input Test Waveform and Measurement Level

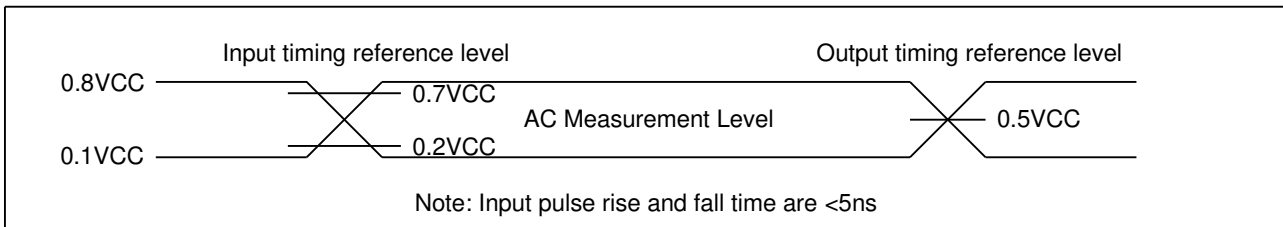

### 8.5. DC CHARACTERISTICS

(T= -40°C~85°C, VCC=1.65~3.6V)

Symbol	Parameter	Test Condition	Min.	Typ.	Max.	Unit.
I <sub>LI</sub>	Input Leakage Current				±2	μA
I <sub>LO</sub>	Output Leakage Current				±2	μA
I <sub>CC1</sub>	Standby Current	CS#=VCC, V <sub>IN</sub> =VCC or VSS		0.1	2	μA
I <sub>CC2</sub>	Deep Power-Down Current	CS#=VCC, V <sub>IN</sub> =VCC or VSS		0.1	2	μA
I <sub>CC3</sub>	Operating Current (Read)	CLK=0.1VCC / 0.9VCC at 100MHz, Q=Open(*1 I/O)		3	6	mA
		CLK=0.1VCC / 0.9VCC at 80MHz, Q=Open(*1 I/O,*2 Output)		2.5	4.5	mA
		CLK=0.1VCC / 0.9VCC at 50MHz, Q=Open(*1 I/O)		1.3	3.5	mA
		CLK=0.1VCC / 0.9VCC at 40MHz, Q=Open(*1 I/O,*2 Output)		1.6	4	mA
		CLK=0.1VCC / 0.9VCC at 16MHz, Q=Open(*1 I/O,*2 Output)		1.2	2.5	mA
I <sub>CC4</sub>	Operating Current (PP)	CS#=VCC			20	mA
I <sub>CC5</sub>	Operating Current (WRSR)	CS#=VCC			20	mA
I <sub>CC6</sub>	Operating Current (SE)	CS#=VCC			20	mA
I <sub>CC7</sub>	Operating Current (BE)	CS#=VCC			20	mA
I <sub>CC8</sub>	Operating Current (CE)	CS#=VCC			20	mA
V <sub>IL</sub>	Input Low Voltage		-0.5		0.2VCC	V
V <sub>IH</sub>	Input High Voltage		0.7VCC		VCC+0.4	V
V <sub>OL</sub>	Output Low Voltage	I <sub>OL</sub> =100μA			0.4	V
V <sub>OH</sub>	Output High Voltage	I <sub>OH</sub> =-100μA	VCC-0.2			V

Note:

1. Typical value tested at T = 25°C. I<sub>CC3</sub> (≥80MHz) tested at VCC = 3.3V. I<sub>CC3</sub> (<80MHz) tested at VCC = 1.8V.
2. Value guaranteed by design and/or characterization, not 100% tested in production.

(T= -40°C~105°C, VCC=1.65~3.6V)

Symbol	Parameter	Test Condition	Min.	Typ.	Max.	Unit.
I <sub>LI</sub>	Input Leakage Current				±2	μA
I <sub>LO</sub>	Output Leakage Current				±2	μA
I <sub>CC1</sub>	Standby Current	CS#=VCC, V <sub>IN</sub> =VCC or VSS		0.1	10	μA
I <sub>CC2</sub>	Deep Power-Down Current	CS#=VCC, V <sub>IN</sub> =VCC or VSS		0.1	10	μA
I <sub>CC3</sub>	Operating Current (Read)	CLK=0.1VCC / 0.9VCC at 100MHz, Q=Open(*1 I/O)		3	22	mA
		CLK=0.1VCC / 0.9VCC at 80MHz, Q=Open(*1 I/O,*2 Output)		2.5	20	mA
		CLK=0.1VCC / 0.9VCC at 40MHz, Q=Open(*1 I/O,*2 Output)		1.6	7	mA
		CLK=0.1VCC / 0.9VCC at 16MHz, Q=Open(*1 I/O,*2 Output)		1.2	5.5	mA
I <sub>CC4</sub>	Operating Current (PP)	CS#=VCC			30	mA
I <sub>CC5</sub>	Operating Current (WRSR)	CS#=VCC			30	mA
I <sub>CC6</sub>	Operating Current (SE)	CS#=VCC			30	mA
I <sub>CC7</sub>	Operating Current (BE)	CS#=VCC			30	mA
I <sub>CC8</sub>	Operating Current (CE)	CS#=VCC			30	mA
V <sub>IL</sub>	Input Low Voltage		-0.5		0.2VCC	V
V <sub>IH</sub>	Input High Voltage		0.7VCC		VCC+0.4	V
V <sub>OL</sub>	Output Low Voltage	I <sub>OL</sub> =100μA			0.4	V
V <sub>OH</sub>	Output High Voltage	I <sub>OH</sub> =-100μA	VCC-0.2			V

Note:

1. Typical value tested at T = 25°C. I<sub>CC3</sub> (≥80MHz) tested at VCC = 3.3V. I<sub>CC3</sub> (<80MHz) tested at VCC = 1.8V.
2. Value guaranteed by design and/or characterization, not 100% tested in production.

(T= -40°C~125°C, VCC=1.65~3.6V)

Symbol	Parameter	Test Condition	Min.	Typ.	Max.	Unit.
I <sub>LI</sub>	Input Leakage Current				±2	μA
I <sub>LO</sub>	Output Leakage Current				±2	μA
I <sub>CC1</sub>	Standby Current	CS#=VCC, V <sub>IN</sub> =VCC or VSS		0.1	15	μA
I <sub>CC2</sub>	Deep Power-Down Current	CS#=VCC, V <sub>IN</sub> =VCC or VSS		0.1	15	μA
I <sub>CC3</sub>	Operating Current (Read)	CLK=0.1VCC / 0.9VCC at 100MHz, Q=Open(*1 I/O)		3	22	mA
		CLK=0.1VCC / 0.9VCC at 80MHz, Q=Open(*1 I/O, *2 Output)		2.5	20	mA
		CLK=0.1VCC / 0.9VCC at 40MHz, Q=Open(*1 I/O, *2 Output)		1.6	7	mA
		CLK=0.1VCC / 0.9VCC at 16MHz, Q=Open(*1 I/O, *2 Output)		1.2	5.5	mA
I <sub>CC4</sub>	Operating Current (PP)	CS#=VCC			30	mA
I <sub>CC5</sub>	Operating Current (WRSR)	CS#=VCC			30	mA
I <sub>CC6</sub>	Operating Current (SE)	CS#=VCC			30	mA
I <sub>CC7</sub>	Operating Current (BE)	CS#=VCC			30	mA
I <sub>CC8</sub>	Operating Current (CE)	CS#=VCC			30	mA
V <sub>IL</sub>	Input Low Voltage		-0.5		0.2VCC	V
V <sub>IH</sub>	Input High Voltage		0.7VCC		VCC+0.4	V
V <sub>OL</sub>	Output Low Voltage	I <sub>OL</sub> =100μA			0.4	V
V <sub>OH</sub>	Output High Voltage	I <sub>OH</sub> =-100μA	VCC-0.2			V

Note:

1. Typical value tested at T = 25°C. I<sub>CC3</sub> (≥80MHz) tested at VCC = 3.3V. I<sub>CC3</sub> (<80MHz) tested at VCC = 1.8V.
2. Value guaranteed by design and/or characterization, not 100% tested in production.

## 8.6. AC CHARACTERISTICS

(T= -40°C~85°C, VCC=1.65~3.6V, C<sub>L</sub>=30pf)

Symbol	Parameter	Min.	Typ.	Max.	Unit.
f <sub>C1</sub>	Serial Clock Frequency For: Fast read (0BH), on 3.0 – 3.6V power supply			100	MHz
f <sub>C2</sub>	Serial Clock Frequency For: Fast read (0BH), on 2.1 – 3.0V power supply			70	MHz
f <sub>C3</sub>	Serial Clock Frequency For: Fast read (0BH), on 1.65 – 2.1V power supply			50	MHz
f <sub>R1</sub>	Serial Clock Frequency For: Read (03H), Dual Output (3BH), on 3.0 – 3.6V power supply			80	MHz
f <sub>R2</sub>	Serial Clock Frequency For: Read (03H), Dual Output (3BH), on 2.1 – 3.0V power supply			60	MHz
f <sub>R3</sub>	Serial Clock Frequency For: Read (03H), Dual Output (3BH), on 1.65 – 2.1V power supply			40	MHz
t <sub>CLH1</sub>	Serial Clock High Time for 2.1 – 3.6V Power Supply	4			ns
t <sub>CLH2</sub>	Serial Clock High Time for 1.65 – 2.1V Power Supply	8			ns
t <sub>CLL1</sub>	Serial Clock Low Time for 2.1 – 3.6V Power Supply	4			ns
t <sub>CLL2</sub>	Serial Clock Low Time for 1.65 – 2.1V Power Supply	8			ns
t <sub>CLCH</sub>	Serial Clock Rise Time (Slew Rate)	0.1			V/ns
t <sub>CHCL</sub>	Serial Clock Fall Time (Slew Rate)	0.1			V/ns
t <sub>SLCH</sub>	CS# Active Setup Time	10			ns
t <sub>CHSH</sub>	CS# Active Hold Time	10			ns
t <sub>SHCH</sub>	CS# Not Active Setup Time	10			ns
t <sub>CHSL</sub>	CS# Not Active Hold Time	10			ns
t <sub>SHSL</sub>	CS# High Time (Read/Write)	40			ns
t <sub>SHQZ</sub>	Output Disable Time			12	ns
t <sub>CLOX</sub>	Output Hold Time	0			ns
t <sub>DVCH</sub>	Data In Setup Time	4			ns
t <sub>CHDX</sub>	Data In Hold Time	4			ns
t <sub>CLQV</sub>	Clock Low To Output Valid			12	ns
t <sub>WHSL</sub>	Write Protect Setup Time Before CS# Low	20			ns
t <sub>SHWL</sub>	Write Protect Hold Time After CS# High	100			ns
t <sub>DP</sub>	CS# High To Deep Power-Down Mode			0.1	μs
t <sub>RES1</sub>	CS# High To Standby Mode Without Electronic Signature Read			0.1	μs
t <sub>RES2</sub>	CS# High To Standby Mode With Electronic Signature Read			0.1	μs
t <sub>w</sub>	Write Status Register Cycle Time		5	40	ms
t <sub>BP1</sub>	Byte Program Time (First Byte)		40	97	μs
t <sub>BP2</sub>	Addition Byte Program Time (After First Byte)		5	10	μs
t <sub>PP</sub>	Page Programming Time		1.6	6	ms
t <sub>SE</sub>	Sector Erase Time		150	500	ms



**Uniform Sector  
Standard and Dual Serial Flash**

**GD25WD40C/20C**

t <sub>BE1</sub>	Block Erase Time (32K Bytes)		0.5	2	s
t <sub>BE2</sub>	Block Erase Time (64K Bytes)		0.8	3	s
t <sub>CE</sub>	Chip Erase Time (GD25WD40C/20C)		6/3	15/7.5	s

Note:

1. Typical values given for TA=25°C VCC = 1.8V.
2. Value guaranteed by design and/or characterization, not 100% tested in production.



(T= -40°C~105°C, VCC=1.65~3.6V, CL=30pf)

Symbol	Parameter	Min.	Typ.	Max.	Unit.
f <sub>C1</sub>	Serial Clock Frequency For: Fast read (0BH), on 3.0 – 3.6V power supply			100	MHz
f <sub>C2</sub>	Serial Clock Frequency For: Fast read (0BH), on 2.1 – 3.0V power supply			70	MHz
f <sub>C3</sub>	Serial Clock Frequency For: Fast read (0BH), on 1.65 – 2.1V power supply			50	MHz
f <sub>R1</sub>	Serial Clock Frequency For: Read (03H), Dual Output (3BH), on 3.0 – 3.6V power supply			80	MHz
f <sub>R2</sub>	Serial Clock Frequency For: Read (03H), Dual Output (3BH), on 2.1 – 3.0V power supply			60	MHz
f <sub>R3</sub>	Serial Clock Frequency For: Read (03H), Dual Output (3BH), on 1.65 – 2.1V power supply			40	MHz
t <sub>CLH1</sub>	Serial Clock High Time for 2.1 – 3.6V Power Supply	4			ns
t <sub>CLH2</sub>	Serial Clock High Time for 1.65 – 2.1V Power Supply	8			ns
t <sub>CLL1</sub>	Serial Clock Low Time for 2.1 – 3.6V Power Supply	4			ns
t <sub>CLL2</sub>	Serial Clock Low Time for 1.65 – 2.1V Power Supply	8			ns
t <sub>CLCH</sub>	Serial Clock Rise Time (Slew Rate)	0.1			V/ns
t <sub>CHCL</sub>	Serial Clock Fall Time (Slew Rate)	0.1			V/ns
t <sub>SLCH</sub>	CS# Active Setup Time	10			ns
t <sub>CHSH</sub>	CS# Active Hold Time	10			ns
t <sub>SHCH</sub>	CS# Not Active Setup Time	10			ns
t <sub>CHSL</sub>	CS# Not Active Hold Time	10			ns
t <sub>SHSL</sub>	CS# High Time (Read/Write)	40			ns
t <sub>SHQZ</sub>	Output Disable Time			12	ns
t <sub>CLQX</sub>	Output Hold Time	0			ns
t <sub>DVCH</sub>	Data In Setup Time	4			ns
t <sub>CHDX</sub>	Data In Hold Time	4			ns
t <sub>CLQV</sub>	Clock Low To Output Valid			12	ns
t <sub>WHSL</sub>	Write Protect Setup Time Before CS# Low	20			ns
t <sub>SHWL</sub>	Write Protect Hold Time After CS# High	100			ns
t <sub>DP</sub>	CS# High To Deep Power-Down Mode			0.1	μs
t <sub>RES1</sub>	CS# High To Standby Mode Without Electronic Signature Read			0.1	μs
t <sub>RES2</sub>	CS# High To Standby Mode With Electronic Signature Read			0.1	μs
t <sub>W</sub>	Write Status Register Cycle Time		5	40	ms
t <sub>BP1</sub>	Byte Program Time (First Byte)		40	110	μs
t <sub>BP2</sub>	Addition Byte Program Time (After First Byte)		5	12	μs
t <sub>PP</sub>	Page Programming Time		1.6	6	ms
t <sub>SE</sub>	Sector Erase Time		150	550	ms
t <sub>BE1</sub>	Block Erase Time (32K Bytes)		0.5	2.2	s
t <sub>BE2</sub>	Block Erase Time (64K Bytes)		0.8	3.5	s



**Uniform Sector  
Standard and Dual Serial Flash**

**GD25WD40C/20C**

t <sub>CE</sub>	Chip Erase Time (GD25WD40C/20C)		6/3	18/9	s
-----------------	---------------------------------	--	-----	------	---

Note:

1. Typical values given for TA=25°C VCC = 1.8V.
2. Value guaranteed by design and/or characterization, not 100% tested in production.

(T= -40°C~125°C, VCC=1.65~3.6V, CL=30pf)

Symbol	Parameter	Min.	Typ.	Max.	Unit.
f <sub>C1</sub>	Serial Clock Frequency For: Fast read (0BH), on 3.0 – 3.6V power supply			100	MHz
f <sub>C2</sub>	Serial Clock Frequency For: Fast read (0BH), on 2.1 – 3.0V power supply			70	MHz
f <sub>C3</sub>	Serial Clock Frequency For: Fast read (0BH), on 1.65 – 2.1V power supply			50	MHz
f <sub>R1</sub>	Serial Clock Frequency For: Read (03H), Dual Output (3BH), on 3.0 – 3.6V power supply			80	MHz
f <sub>R2</sub>	Serial Clock Frequency For: Read (03H), Dual Output (3BH), on 2.1 – 3.0V power supply			60	MHz
f <sub>R3</sub>	Serial Clock Frequency For: Read (03H), Dual Output (3BH), on 1.65 – 2.1V power supply			40	MHz
t <sub>CLH1</sub>	Serial Clock High Time for 2.1 – 3.6V Power Supply	4			ns
t <sub>CLH2</sub>	Serial Clock High Time for 1.65 – 2.1V Power Supply	8			ns
t <sub>CLL1</sub>	Serial Clock Low Time for 2.1 – 3.6V Power Supply	4			ns
t <sub>CLL2</sub>	Serial Clock Low Time for 1.65 – 2.1V Power Supply	8			ns
t <sub>CLCH</sub>	Serial Clock Rise Time (Slew Rate)	0.1			V/ns
t <sub>CHCL</sub>	Serial Clock Fall Time (Slew Rate)	0.1			V/ns
t <sub>SLCH</sub>	CS# Active Setup Time	10			ns
t <sub>CHSH</sub>	CS# Active Hold Time	10			ns
t <sub>SHCH</sub>	CS# Not Active Setup Time	10			ns
t <sub>CHSL</sub>	CS# Not Active Hold Time	10			ns
t <sub>SHSL</sub>	CS# High Time (Read/Write)	40			ns
t <sub>SHQZ</sub>	Output Disable Time			12	ns
t <sub>CLQX</sub>	Output Hold Time	0			ns
t <sub>DVCH</sub>	Data In Setup Time	4			ns
t <sub>CHDX</sub>	Data In Hold Time	4			ns
t <sub>CLQV</sub>	Clock Low To Output Valid			12	ns
t <sub>WHSL</sub>	Write Protect Setup Time Before CS# Low	20			ns
t <sub>SHWL</sub>	Write Protect Hold Time After CS# High	100			ns
t <sub>DP</sub>	CS# High To Deep Power-Down Mode			0.1	μs
t <sub>RES1</sub>	CS# High To Standby Mode Without Electronic Signature Read			0.1	μs
t <sub>RES2</sub>	CS# High To Standby Mode With Electronic Signature Read			0.1	μs
t <sub>W</sub>	Write Status Register Cycle Time		5	40	ms
t <sub>BP1</sub>	Byte Program Time (First Byte)		40	120	μs
t <sub>BP2</sub>	Addition Byte Program Time (After First Byte)		5	14	μs
t <sub>PP</sub>	Page Programming Time		1.6	6	ms
t <sub>SE</sub>	Sector Erase Time		150	600	ms
t <sub>BE1</sub>	Block Erase Time (32K Bytes)		0.5	2.5	s
t <sub>BE2</sub>	Block Erase Time (64K Bytes)		0.8	4	s

t <sub>CE</sub>	Chip Erase Time (GD25WD40C/20C)		6/3	20/10	s
-----------------	---------------------------------	--	-----	-------	---

Note:

1. Typical values given for TA=25°C VCC = 1.8V.
2. Value guaranteed by design and/or characterization, not 100% tested in production.

**Figure21. Serial Input Timing**

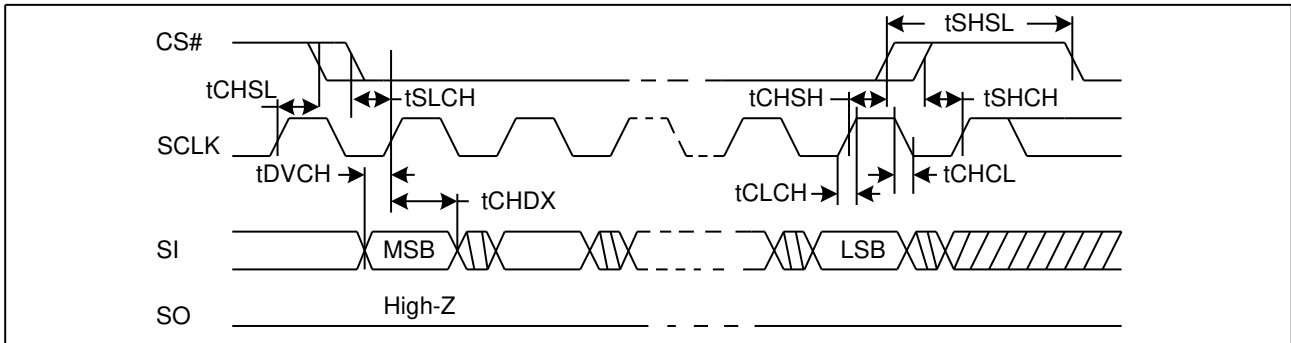

**Figure22. Output Timing**

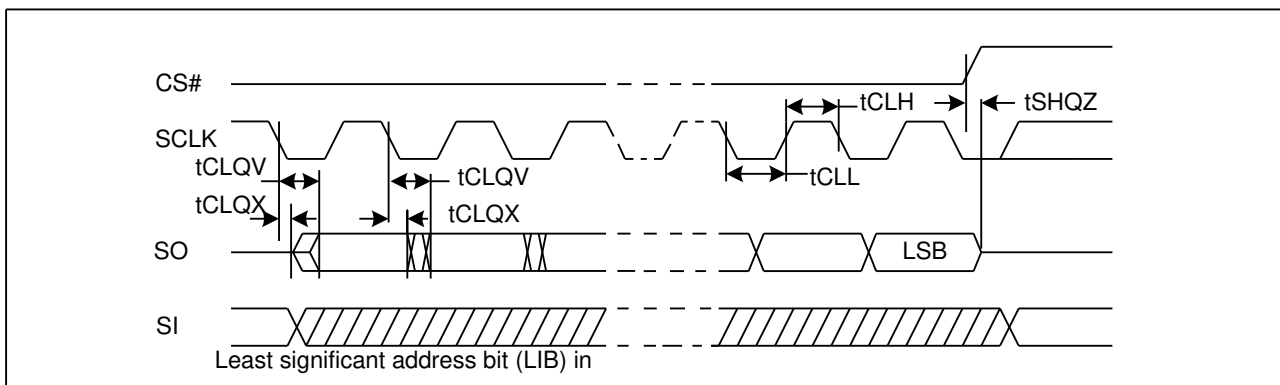

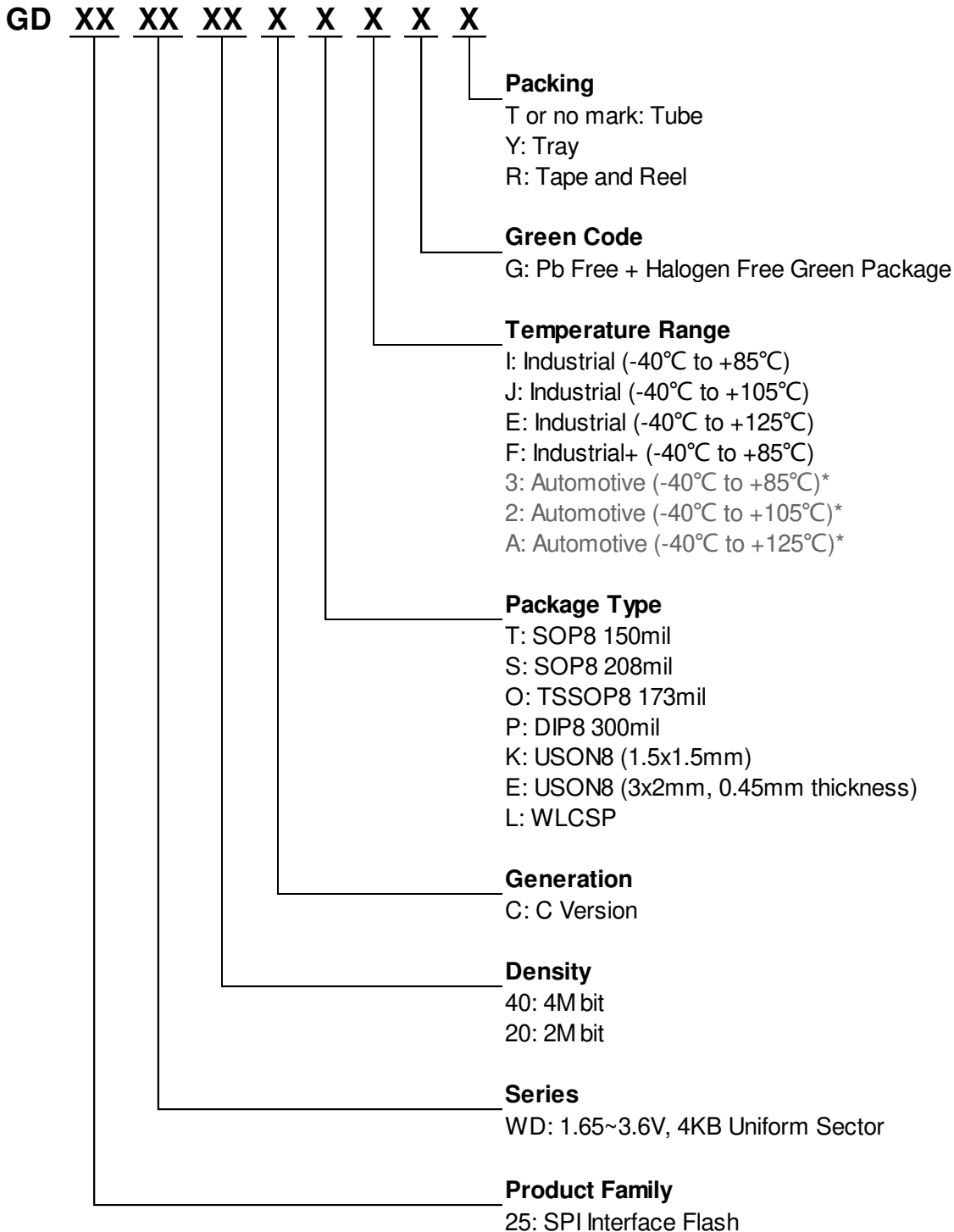
**9. ORDERING INFORMATION**

\* Please contact GigaDevice sales for automotive products.



**9.1. Valid Part Numbers**

Please contact GigaDevice regional sales for the latest product selection and available form factors.

**Temperature Range I: Industrial (-40°C to +85°C)**

Product Number	Density	Package Type
GD25WD40CTIG	4Mbit	SOP8 150mil
GD25WD20CTIG	2Mbit	
GD25WD40CSIG	4Mbit	SOP8 208mil
GD25WD20CSIG	2Mbit	
GD25WD40COIG	4Mbit	TSSOP8 173mil
GD25WD20COIG	2Mbit	
GD25WD40CPIG	4Mbit	DIP8 300mil
GD25WD20CPIG	2Mbit	
GD25WD40CKIG	4Mbit	USON8 (1.5x1.5mm)
GD25WD20CKIG	2Mbit	
GD25WD40CEIG	4Mbit	USON8 (3x2mm, 0.45mm thickness)
GD25WD20CEIG	2Mbit	
GD25WD40CLIGR	4Mbit	WLCSP

**Temperature Range J: Industrial (-40°C to +105°C)**

Product Number	Density	Package Type
GD25WD40CTJG	4Mbit	SOP8 150mil
GD25WD20CTJG	2Mbit	
GD25WD40CSJG	4Mbit	SOP8 208mil
GD25WD20CSJG	2Mbit	
GD25WD40COJG	4Mbit	TSSOP8 173mil
GD25WD20COJG	2Mbit	
GD25WD40CPJG	4Mbit	DIP8 300mil
GD25WD20CPJG	2Mbit	
GD25WD40CKJG	4Mbit	USON8 (1.5x1.5mm)
GD25WD20CKJG	2Mbit	
GD25WD40CEJG	4Mbit	USON8 (3x2mm, 0.45mm thickness)
GD25WD20CEJG	2Mbit	
GD25WD40CLJGR	4Mbit	WLCSP



**Temperature Range E: Industrial (-40°C to +125°C)**

Product Number	Density	Package Type
GD25WD40CTEG	4Mbit	SOP8 150mil
GD25WD20CTEG	2Mbit	
GD25WD40CSEG	4Mbit	SOP8 208mil
GD25WD20CSEG	2Mbit	
GD25WD40COEG	4Mbit	TSSOP8 173mil
GD25WD20COEG	2Mbit	
GD25WD40CEEG	4Mbit	DIP8 300mil
GD25WD20CEEG	2Mbit	
GD25WD40CKEG	4Mbit	USON8 (1.5x1.5mm)
GD25WD20CKEG	2Mbit	
GD25WD40CEEG	4Mbit	USON8 (3x2mm, 0.45mm thickness)
GD25WD20CEEG	2Mbit	
GD25WD40CLEGR	4Mbit	WLCSP

**Temperature Range F: Industrial+ (-40°C to +85°C)**

Product Number	Density	Package Type
GD25WD40CTFG	4Mbit	SOP8 150mil
GD25WD20CTFG	2Mbit	
GD25WD40CSFG	4Mbit	SOP8 208mil
GD25WD20CSFG	2Mbit	
GD25WD40COFG	4Mbit	TSSOP8 173mil
GD25WD20COFG	2Mbit	
GD25WD40CPFG	4Mbit	DIP8 300mil
GD25WD20CPFG	2Mbit	
GD25WD40CKFG	4Mbit	USON8 (1.5x1.5mm)
GD25WD20CKFG	2Mbit	
GD25WD40CEFG	4Mbit	USON8 (3x2mm, 0.45mm thickness)
GD25WD20CEFG	2Mbit	
GD25WD40CLFGR	4Mbit	WLCSP

## 10. PACKAGE INFORMATION

### 10.1. Package SOP8 150MIL

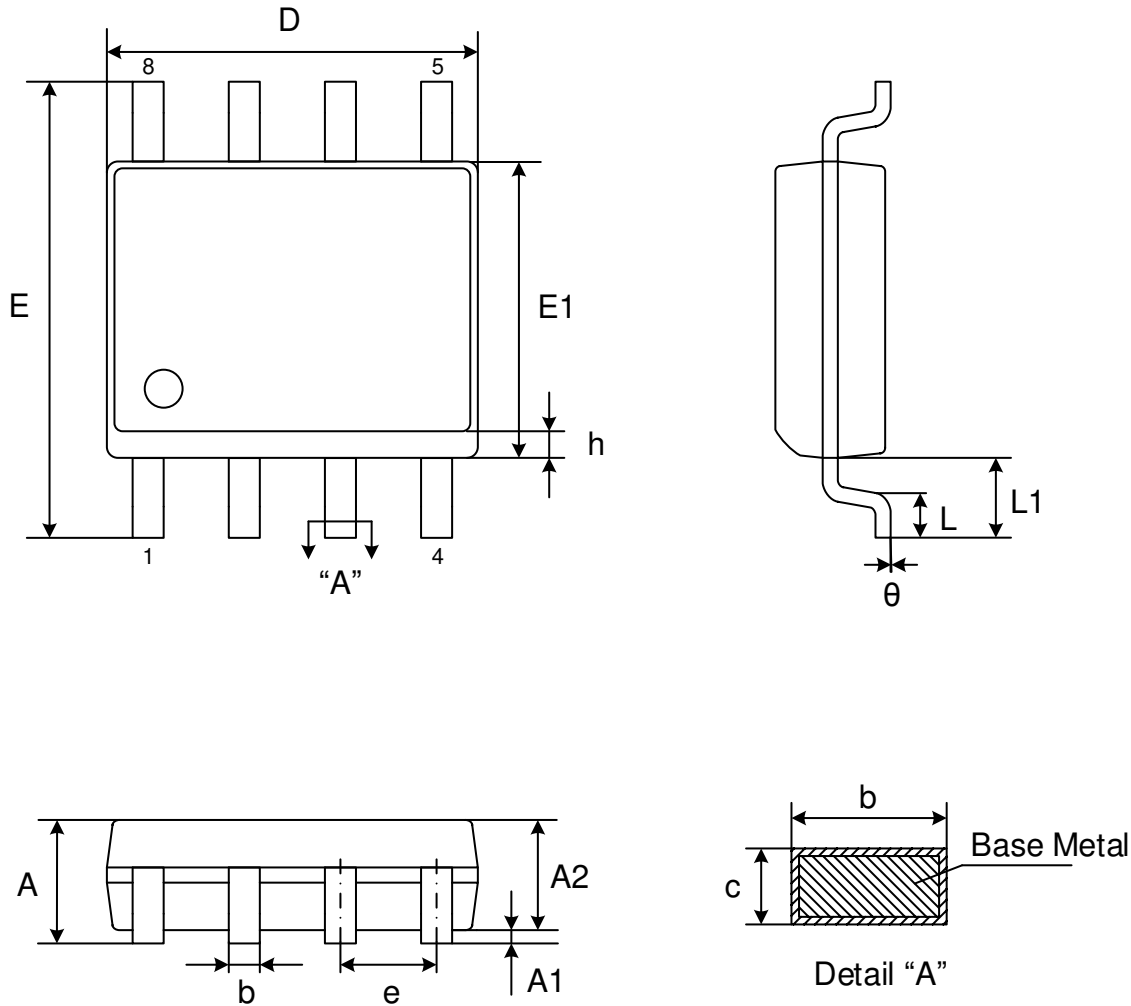

### Dimensions

Symbol		A	A1	A2	b	c	D	E	E1	e	L	L1	h	$\theta$
Unit														
mm	Min	-	0.10	1.25	0.31	0.10	4.80	5.80	3.80	1.27	0.40	1.04	0.25	0°
	Nom	-	0.15	1.45	0.41	0.20	4.90	6.00	3.90		-		-	
	Max	1.75	0.25	1.55	0.51	0.25	5.00	6.20	4.00		0.90		0.50	8°

Note:

- Both the package length and width include the mold flash.
- Seating plane: Max. 0.1mm.



10.2. Package SOP8 208MIL

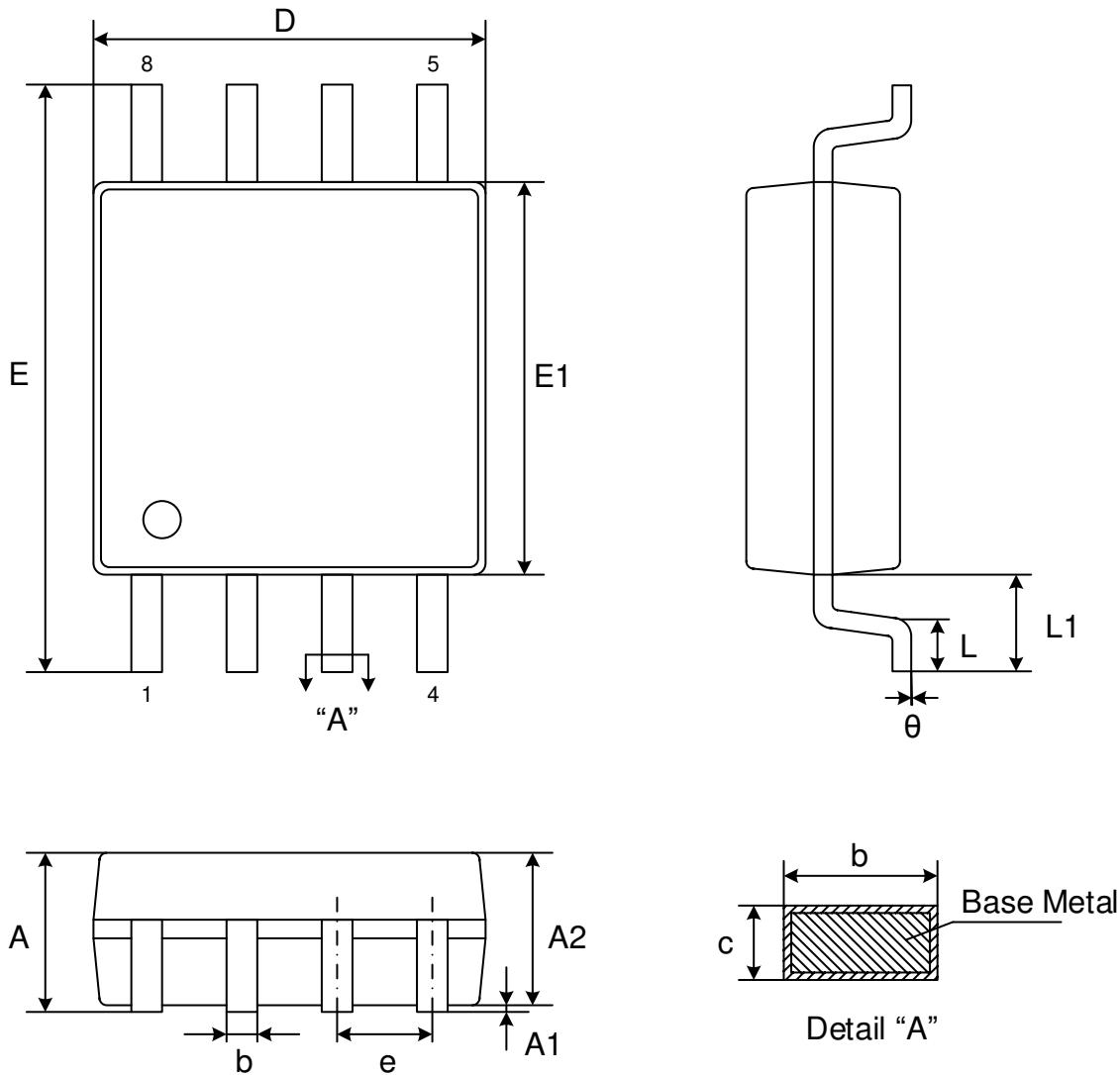

Dimensions

Symbol		A	A1	A2	b	c	D	E	E1	e	L	L1	θ
Unit													
mm	Min	-	0.05	1.70	0.31	0.15	5.13	7.70	5.18	1.27	0.50	1.31	0°
	Nom	-	0.15	1.80	0.41	0.20	5.23	7.90	5.28		-		-
	Max	2.16	0.25	1.90	0.51	0.25	5.33	8.10	5.38		0.85		8°

Note:

- Both the package length and width do not include the mold flash.
- Seating plane: Max. 0.1mm.

10.3. Package TSSOP8 173MIL

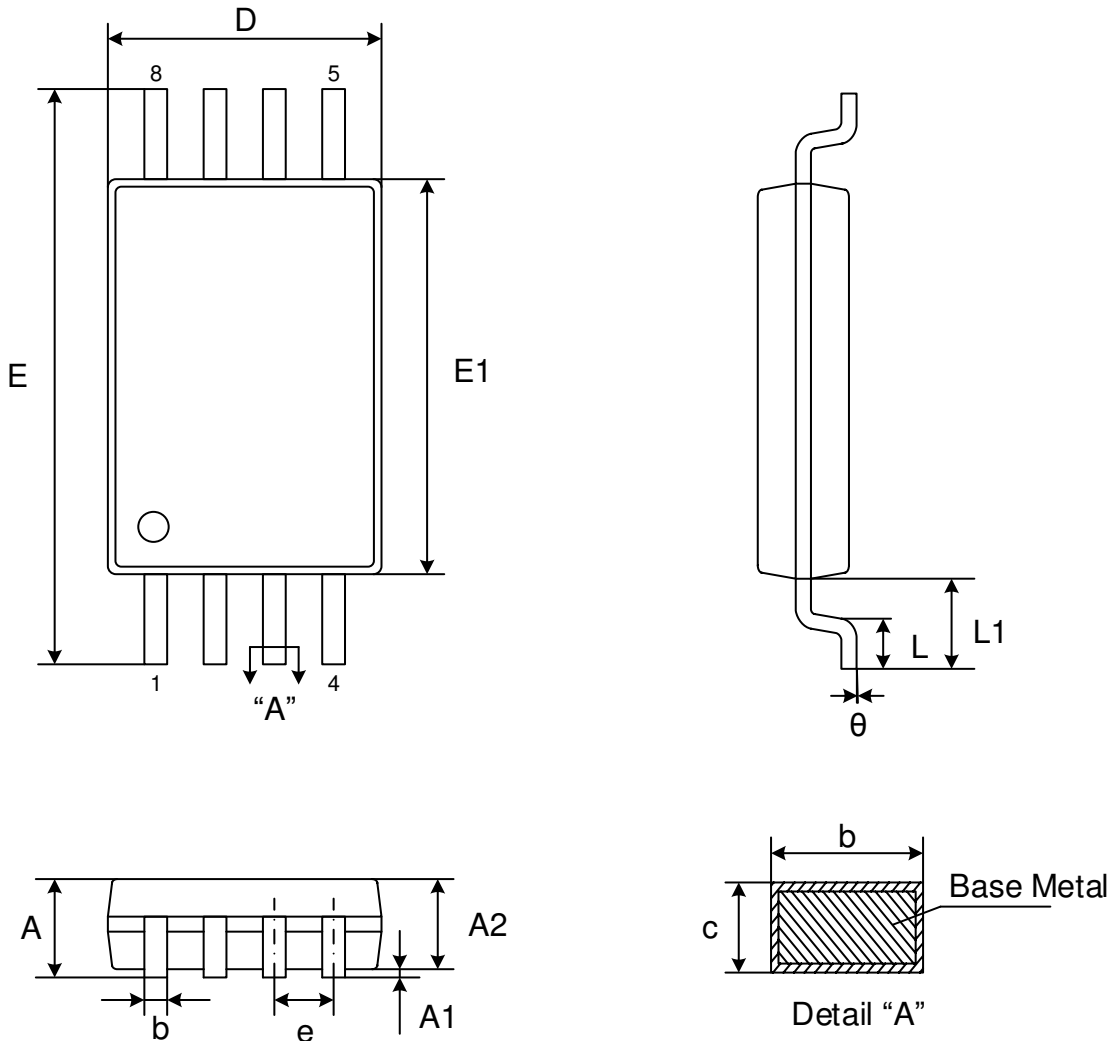

Dimensions

Symbol	A	A1	A2	b	c	D	E	E1	e	L	L1	theta	
Unit													
mm	Min	-	0.05	0.80	0.19	0.09	2.90	6.20	4.30	0.65	0.45	1.00	0°
	Nom	-	0.10	1.00	0.25	0.15	3.00	6.40	4.40		-		-
	Max	1.20	0.15	1.05	0.30	0.20	3.10	6.60	4.50		0.75		8°

Notes:

- Both package length and width do not include mold flash.
- Seating plane: Max. 0.1mm.

10.4. Package DIP8 300MIL

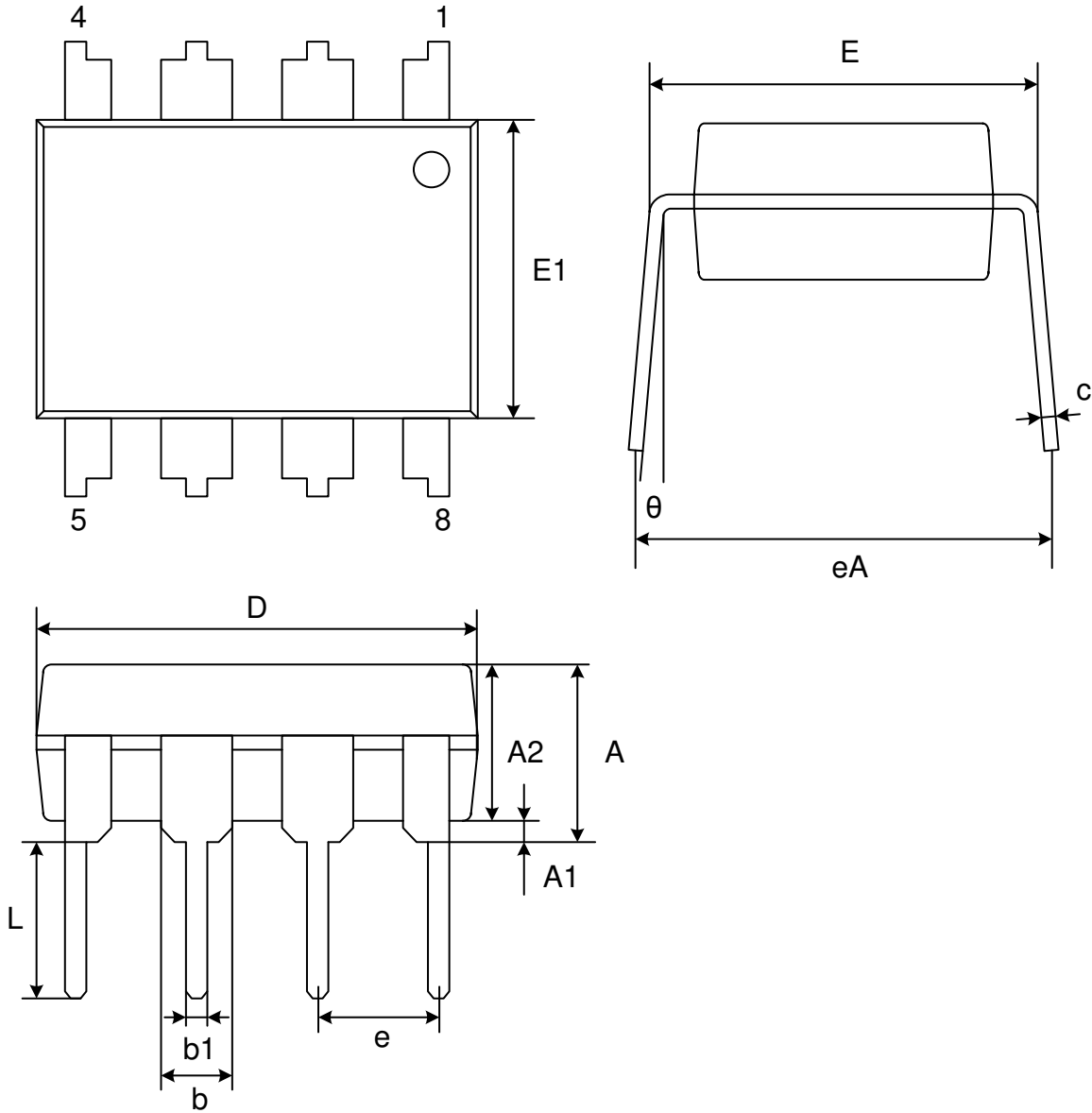

Dimensions

Symbol	A	A1	A2	b	b1	C	D	E	E1	e	L	eA	$\theta$	
Unit														
mm	Min	-	0.38	3.00	1.14	0.36	0.20	9.02	7.62	6.10	2.54	2.92	8.45	0°
	Nom	-	-	3.30	1.52	0.46	0.25	9.27	7.87	6.35		3.30	8.90	-
	Max	3.88	-	3.50	1.78	0.56	0.35	9.59	8.26	6.60		3.81	9.35	11°

Note: Both the package length and width do not include the mold flash.

10.5. Package USON8 (1.5\*1.5mm)

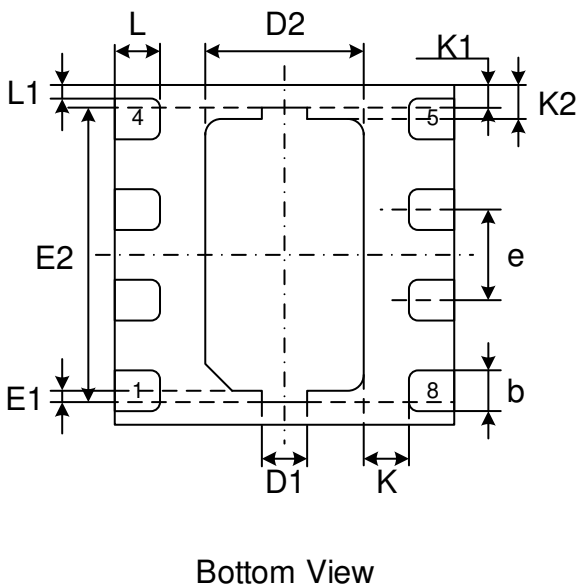
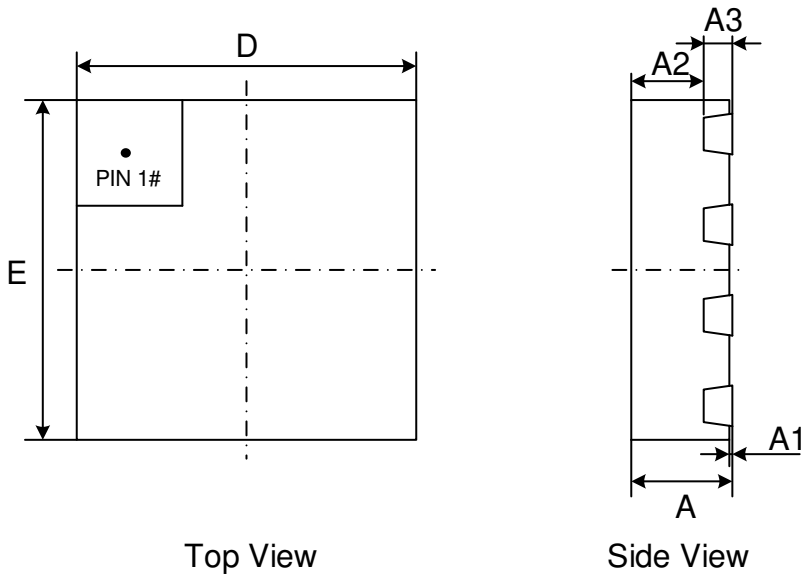

Dimensions

Symbol	A	A1	A2	A3	b	D	E	D1	E1	D2	E2	e	L	L1	K	K1	K2	
Unit																		
mm	Min	0.40	0.00	0.33	0.127	0.13	1.40	1.40	0.20	0.05	0.60	1.20	0.40	0.15	0.06	0.20	0.10	0.15
	Nom	0.45	0.02			REF	REF	0.18			1.50	1.50		REF				
	Max	0.50	0.05			0.25	1.60	1.60			0.80	1.40		0.25				

Note:

- Both the package length and width do not include the mold flash.
- The exposed metal pad area on the bottom of the package is floating.
- Coplanarity  $\leq 0.08\text{mm}$ . Package edge tolerance  $\leq 0.10\text{mm}$ .
- The lead shape may be of little difference according to different package factories. These lead shapes are compatible with each other.

**10.6. Package USON8 (3\*2mm, thickness 0.45mm)**

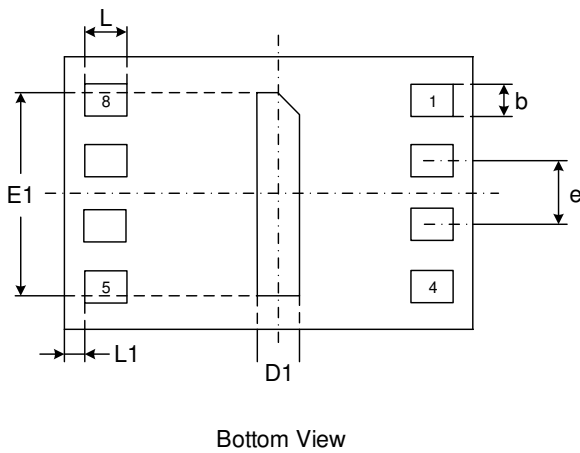
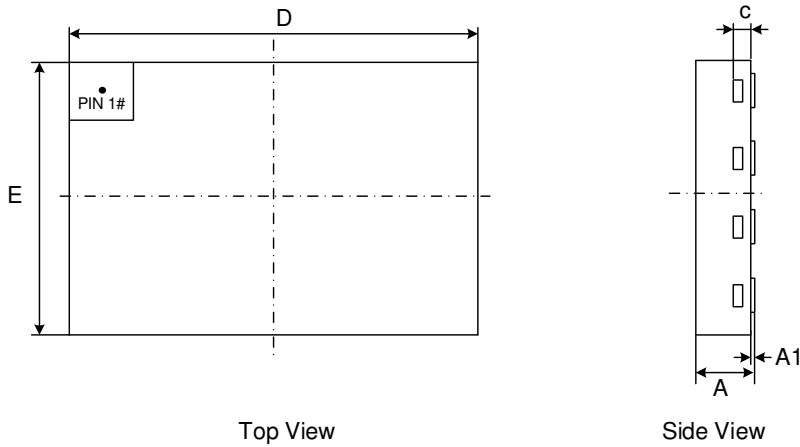

**Dimensions**

Symbol		A	A1	c	b	D	D1	E	E1	e	L	L1
Unit												
mm	Min	0.40	0.00	0.10	0.20	2.90	0.15	1.90	1.55	0.50	0.30	0.10
	Nom	0.45	0.02	0.15	0.25	3.00	0.20	2.00	1.60		0.35	
	Max	0.50	0.05	0.20	0.30	3.10	0.25	2.10	1.65		0.40	

Note:

1. Both the package length and width do not include the mold flash.
2. The exposed metal pad area on the bottom of the package is floating.
3. Coplanarity  $\leq 0.08\text{mm}$ . Package edge tolerance  $\leq 0.10\text{mm}$ .
4. The lead shape may be of little difference according to different package factories. These lead shapes are compatible with each other.

10.7. Package WLCSP

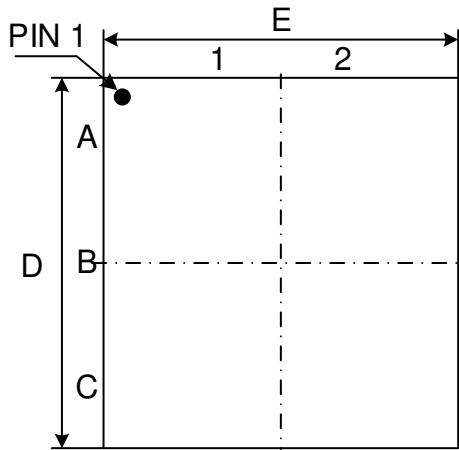

Top View  
(Mark Side)

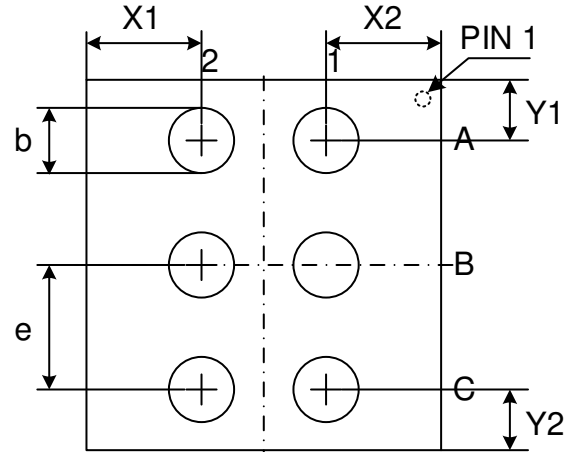

Bottom View  
(Ball Side)

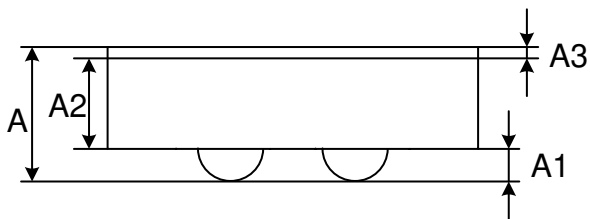

Side View

Dimensions

Symbol		A	A1	A2	A3	e	b
Unit							
mm	Min	0.280	0.072	0.175	0.025 BSC	0.275 BSC	0.144
	Nom	0.305	0.080	0.200			0.160
	Max	0.330	0.088	0.225			0.176

Note:

1. Please contact GigaDevice for full dimension information.

## 11. REVISION HISTORY

Version No	Description	Page	Date
1.0	Initial Release	ALL	2017-6-20
1.1	Modify AC CHARACTERISTICS: fc, fR	P27	2017-6-29
1.2	Modify VWI in Table 5 from 1.4 to 1.5 Add lcc3 at 50MHz. Typ.= 6mA; Max. = 8mA	P24 P24	2017-7-10
1.3	Modify ID15-ID8 from 40 to 64 Add Transient Input/Output Voltage of "-2.0V to VCC+2.0V" Modify tpp max. value from 4ms to 6ms	P13 P24 P27	2017-7-13
1.4	Modify lcc3 @50MHz from 6-8mA to 5-7mA Modify lcc3 @40MHz from 6-8mA to 3.5-5mA Add lcc3 @16MHz of 2.2-4mA	P26 P26 P26	2017-8-23
1.5	Modify the description of 60/C7H command: delete "or all 1" at the end of the last but one sentence. Modify the description of ABH command: modify "figure 14" to "figure 15" at the end of 2 <sup>nd</sup> sentence in 3 <sup>rd</sup> paragraph. Modify VCC from "-0.5 to 4.2" to "-0.6 to 4.2". Modify tw from 4-30ms to 5-40ms Add lcc8 in DC CHARACTERISTICS, of which the max. value is 15mA. Add tBP1 of 15-30us and tBP2 of 2.5-5us in AC CHARACTERISTICS. Modify tCE of GD25WD40C from 5-10s to 6-15s. Modify tCE of GD25WD20C from 2.5-6s to 3-7.5s. Modify tBE(64K Bytes) max. value from 2.5s to 3s. Classify fC and fR by power supply. fc max. values are 100MHz, 70MHz and 50MHz for 3.0-3.6V, 2.1-3.0V, 1.65-2.1V. fR max values are 80MHz, 60MHz and 40MHz for 3.0-3.6V, 2.1-3.0V, 1.65-2.1V. Add lcc3 @100MHz of 13-18mA and @80MHz of 12-15mA. Modify tCLH and tCLL from 8ns to 4ns Delete lcc3 @50MHz Modify lcc4-lcc7 max value from 10mA to 15mA	P20 P21 P24 P27 P26 P27 P27 P27 P27 P27 P26 P27 P26 P26	2017-8-28
1.6	Modify tCLH and tCLL for 1.65 – 2.1V power supply from 4ns to 8ns Update the description all packages	P27 P31-35	2017-12-25
1.7	Modify lcc1 max. value from 1uA to 2uA Modify lcc2 max. value from 1uA to 2uA Modify tBP1 from 15~30us to 40~97us Modify tBP2 from 2.5~5us to 5~10us Modify tVSL min value from 5ms to 0.5ms Add "J" and "E" to 7 <sup>th</sup> code of Ordering Information	P26 P26 P27 P27 P24 P29	2018-4-19
1.8	Add DC/AC characteristics @-40°C~105°C Add DC/AC characteristics @-40°C~125°C Modify Ordering Information	P27/31 P28/32 P35	2018-7-11
1.9	Modify VWI max value from 1.5V to 1.55V Modify tVSL max value from 0.5ms to 0.3ms	P24 P24	2018-10-24



**Uniform Sector  
Standard and Dual Serial Flash**

**GD25WD40C/20C**

	Add Package USON8 1.5*1.5mm Add Package WLCSP	P43 P45	
2.0	Modify lcc3 typ. value @100MHz from 13mA to 3mA Modify lcc3 typ. value @80MHz from 12mA to 2.5mA Modify lcc3 typ. value @40MHz from 3.5mA to 1.6mA Modify lcc3 typ. value @16MHz from 2.2mA to 1.2mA Modify lcc3 max. value @100MHz @-40°C to 85°C from 18mA to 6mA Modify lcc3 max. value @80MHz @-40°C to 85°C from 15mA to 4.5mA Add lcc3 @50MHz @-40°C-85°C of 1.3~3.5mA Modify "L" (min) of USON8 1.5x1.5 package from 0.125mm to 0.15mm	P28, 29, 30 P28, 29, 30 P28, 29, 30 P28, 29, 30 P28 P28 P28 P44	2019-4-30



## Important Notice

This document is the property of GigaDevice Semiconductor (Beijing) Inc. and its subsidiaries (the "Company"). This document, including any product of the Company described in this document (the "Product"), is owned by the Company under the intellectual property laws and treaties of the People's Republic of China and other jurisdictions worldwide. The Company reserves all rights under such laws and treaties and does not grant any license under its patents, copyrights, trademarks, or other intellectual property rights. The names and brands of third party referred thereto (if any) are the property of their respective owner and referred to for identification purposes only.

The Company makes no warranty of any kind, express or implied, with regard to this document or any Product, including, but not limited to, the implied warranties of merchantability and fitness for a particular purpose. The Company does not assume any liability arising out of the application or use of any Product described in this document. Any information provided in this document is provided only for reference purposes. It is the responsibility of the user of this document to properly design, program, and test the functionality and safety of any application made of this information and any resulting product. Except for customized products which has been expressly identified in the applicable agreement, the Products are designed, developed, and/or manufactured for ordinary business, industrial, personal, and/or household applications only. The Products are not designed, intended, or authorized for use as components in systems designed or intended for the operation of weapons, weapons systems, nuclear installations, atomic energy control instruments, combustion control instruments, airplane or spaceship instruments, traffic signal instruments, life-support devices or systems, other medical devices or systems (including resuscitation equipment and surgical implants), pollution control or hazardous substances management, or other uses where the failure of the device or Product could cause personal injury, death, property or environmental damage ("Unintended Uses"). Customers shall take any and all actions to ensure using and selling the Products in accordance with the applicable laws and regulations. The Company is not liable, in whole or in part, and customers shall and hereby do release the Company as well as it's suppliers and/or distributors from any claim, damage, or other liability arising from or related to all Unintended Uses of the Products. Customers shall indemnify and hold the Company as well as it's suppliers and/or distributors harmless from and against all claims, costs, damages, and other liabilities, including claims for personal injury or death, arising from or related to any Unintended Uses of the Products. Customers shall discard the device according to the local environmental law.

**Information in this document is provided solely in connection with the Products. The Company reserves the right to make changes, corrections, modifications or improvements to this document and the Products and services described herein at any time, without notice.**