

**COMP-O-GIDE™****Industry Standard Snap-in Card Guides for 1/16<sup>th</sup> PCBs**

- 52 configurations to meet most standard requirements
- Precision Molded for rigidity, strength and heat resistance from 94V-2 UL rated materials
- Stainless Steel Conductive Inserts available for all sizes (see page 19)
- Two channel depths and two channel widths available to accommodate 1/16<sup>th</sup> & 3/32<sup>nd</sup> PCBs
- Common industry standards interchange with competitive devices

**COMP-O-GIDE**, was introduced in 1985 to provide second sources for previously single source card guides. The series has expanded to offer wider selection and application specific function. Rigid, strong and economical, COMP-O-GIDES provide the installed reliability that your most demanding products require. Retention is firm and there are no special tools or fixtures required for installation.

**Mounting Information:**

Snap-in metal plates: 0.047" - 0.090" (1.2mm - 2.3mm) thick  
Hole Size: 0.180" (4.6mm) diameter + 0.003 (0.08mm), - 0.001 (0.03mm) 3/16<sup>th</sup> drill

**Material Specifications:**

UL Rated 94V-2, natural, 6/6 Nylon per ASTM D4066 PA111  
Oxygen Index: +28%  
UL File #E135532

**Application Notes:**

Slotting or elongating of the second and third mounting hole is recommended to allow for length variations and to provide for easier assembly.

Prolonged pre-assembly exposure to high humidity can cause molded Nylon components to "grow" out of tolerance. Storage in a cool dry place is recommended. Open sealed vapor barrier bags at the time of production to assure optimum shelf life.

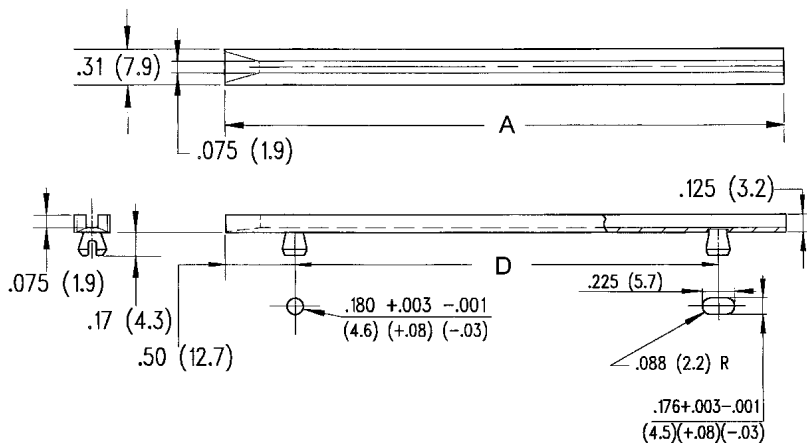
**Comp-O-Gide for 1/16<sup>th</sup> PCBs  
2 1/2" thru 8" Lengths**

Part No.	A ±.031 (.79)	B ±.016 (.41)
SFS-250	2.5 (63.5)	1.5 (38.1)
SFS-300	3.0 (76.2)	2.0 (50.8)
SFS-350	3.5 (88.9)	2.5 (63.5)
SFS-400	4.0 (101.6)	3.0 (76.2)
SFS-450	4.5 (114.3)	3.0 (76.2)
SFS-451	4.5 (114.3)	3.5 (88.9)
SFS-500	5.0 (127.0)	4.0 (101.6)
SFS-550	5.5 (139.7)	4.5 (114.3)
SFS-600	6.0 (152.4)	5.0 (127.0)
SFS-650	6.5 (165.1)	5.02 (127.5)
SFS-651	6.5 (165.1)	5.5 (139.7)
SFS-700	7.0 (177.8)	6.0 (152.4)
SFS-750	7.5 (190.5)	6.5 (165.1)
SFS-800	8.0 (203.2)	7.0 (177.8)