



STEVAL-IHM040V1

BLDC/PMSM driver demonstration board based on STM32 and the SLLIMM™ nano

Data brief

Features

- Extended AC input mains range: 115 or 230 VAC nominal at 50/60 Hz, or DC input voltage between 150 and 350 VDC
- Output current: 0.5 A_{RMS} to the motor
- Power stage: 3-phase inverter bridge implemented using the STGIPN3H60 SLLIMM-nano intelligent power module
- RoHS compliant

Description

The STEVAL-IHM040V1 is a 3-phase permanent magnet brushless motor driver designed to drive a motor using either the six step or field oriented control (FOC) commutation technique. The board can operate from an AC mains of either 115 or 230 V_{AC} nominal at 50/60 Hz, or from a DC input voltage between 150 and 350 VDC. The board can supply a continuous output current of 0.5 A_{RMS} to the motor.

The circuit consists of three main blocks. The first is the digital control block, which uses the STM32F100C8T6 microcontroller to implement the control algorithms and to generate the control signals for the power stage. The main outputs of the control block are the signals for the power stage.

The second block is the power stage, a 3-phase inverter bridge implemented using the STGIPN3H60 SLLIMM-nano intelligent power module. The SLLIMM includes the 6 IGBTs, gate drivers and level shift required to interface the logic signals from the digital control to the motor terminals. The SLLIMM also provides a hardware overcurrent shutdown and an op-amp used to scale and bias the current sensing.



The third block is the power supply, which employs the VIPER16 to convert the high voltage DC bus to a regulated 15 V supply that supplies the SLLIMM and analog circuitry on the board. The 15 V supply also supplies an L78L33 linear regulator that provides the 3.3 V logic supply for the microcontroller.

Two firmware control programs are available, one for six steps and one for FOC, which run on the same hardware platform.

1 Schematic diagrams

Figure 1. SLLIMM-based BLDC driver (1 of 3)

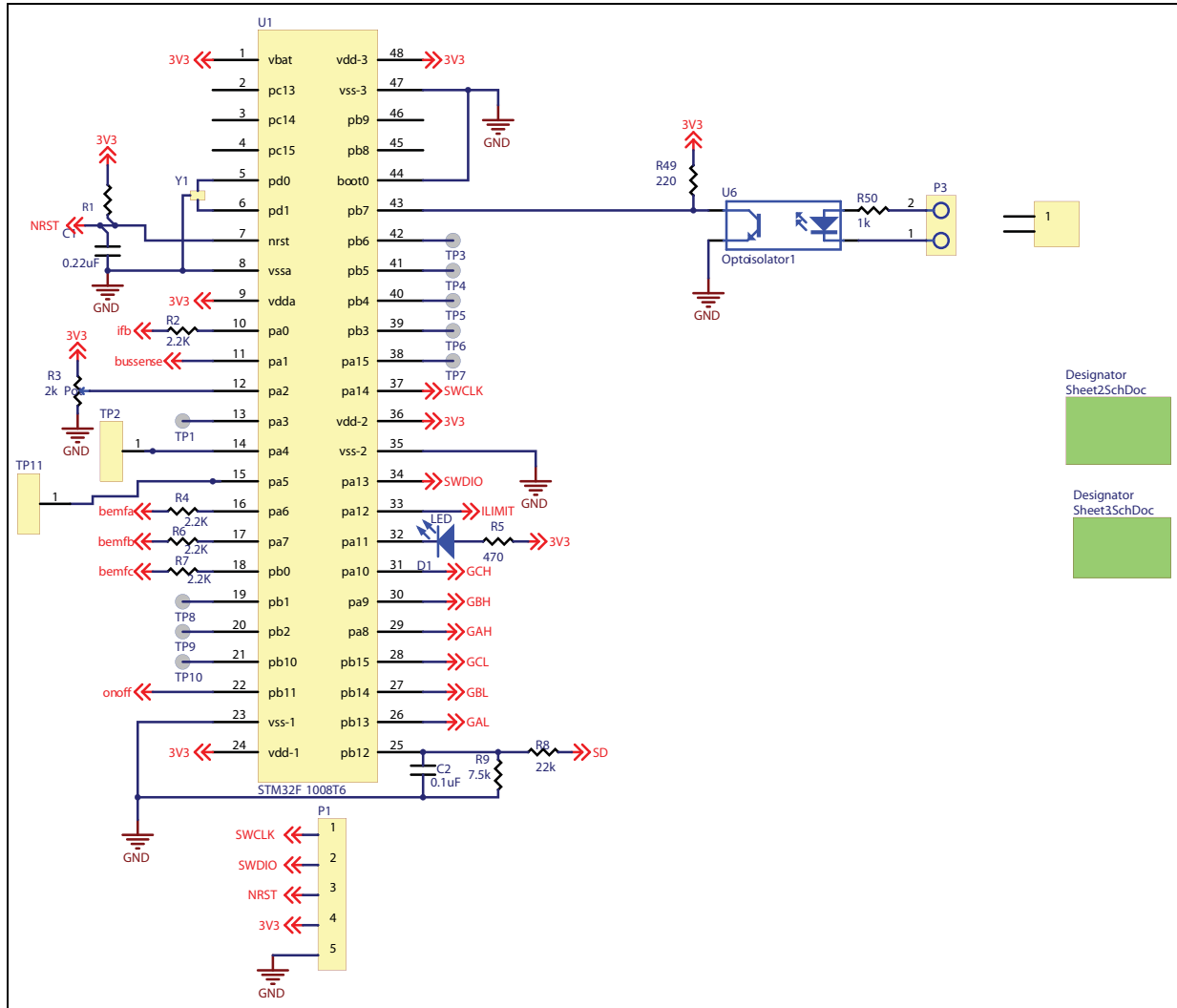

Designator Sheet2SchDoc

Designator Sheet3SchDoc

Figure 2. SLLIMM-based BLDC driver (2 of 3)

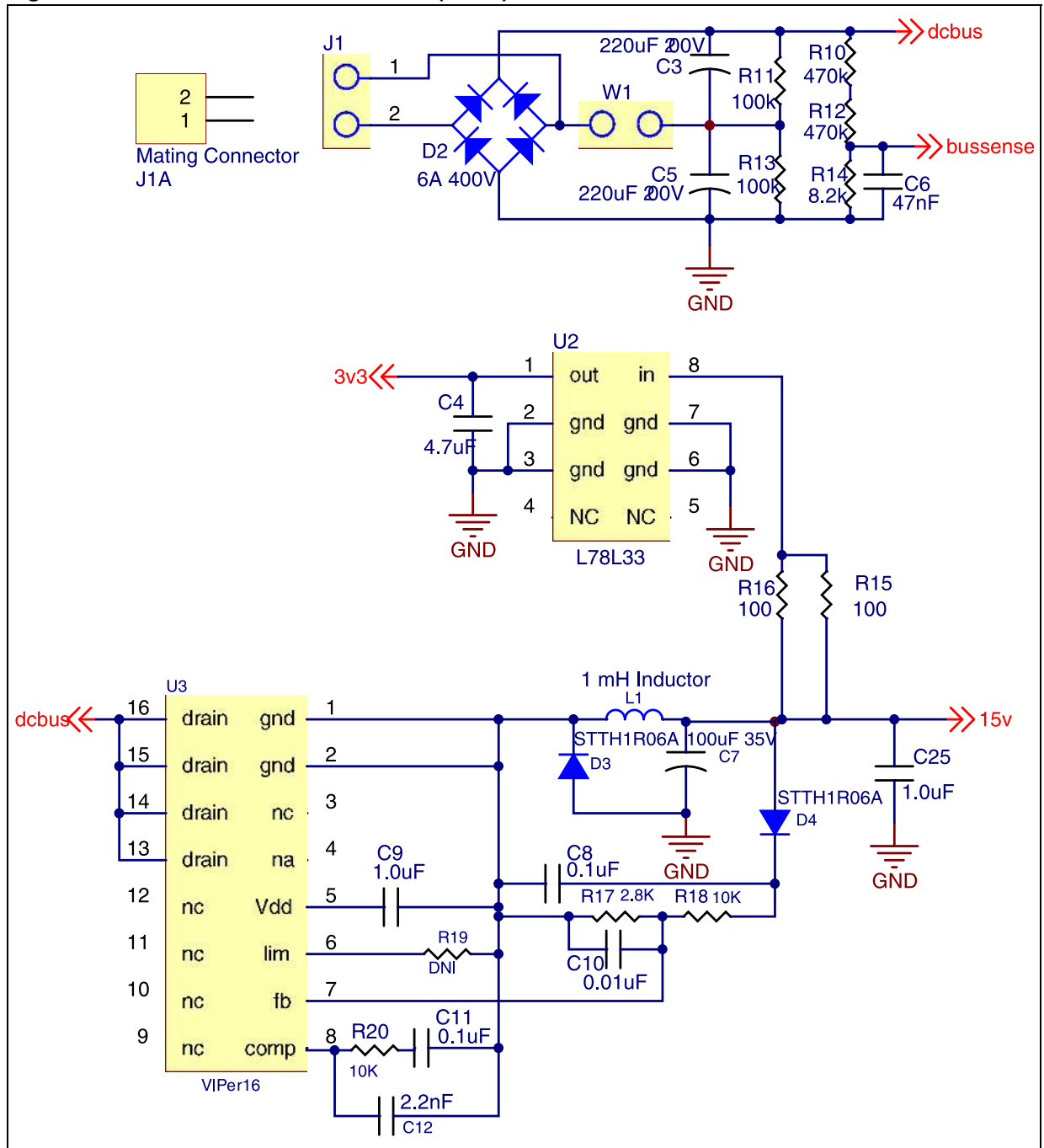

2 Revision history

Table 1. Document revision history

Date	Revision	Changes
19-Dec-2012	1	Initial release.

Please Read Carefully:

Information in this document is provided solely in connection with ST products. STMicroelectronics NV and its subsidiaries ("ST") reserve the right to make changes, corrections, modifications or improvements, to this document, and the products and services described herein at any time, without notice.

All ST products are sold pursuant to ST's terms and conditions of sale.

Purchasers are solely responsible for the choice, selection and use of the ST products and services described herein, and ST assumes no liability whatsoever relating to the choice, selection or use of the ST products and services described herein.

No license, express or implied, by estoppel or otherwise, to any intellectual property rights is granted under this document. If any part of this document refers to any third party products or services it shall not be deemed a license grant by ST for the use of such third party products or services, or any intellectual property contained therein or considered as a warranty covering the use in any manner whatsoever of such third party products or services or any intellectual property contained therein.

UNLESS OTHERWISE SET FORTH IN ST'S TERMS AND CONDITIONS OF SALE ST DISCLAIMS ANY EXPRESS OR IMPLIED WARRANTY WITH RESPECT TO THE USE AND/OR SALE OF ST PRODUCTS INCLUDING WITHOUT LIMITATION IMPLIED WARRANTIES OF MERCHANTABILITY, FITNESS FOR A PARTICULAR PURPOSE (AND THEIR EQUIVALENTS UNDER THE LAWS OF ANY JURISDICTION), OR INFRINGEMENT OF ANY PATENT, COPYRIGHT OR OTHER INTELLECTUAL PROPERTY RIGHT.

UNLESS EXPRESSLY APPROVED IN WRITING BY TWO AUTHORIZED ST REPRESENTATIVES, ST PRODUCTS ARE NOT RECOMMENDED, AUTHORIZED OR WARRANTED FOR USE IN MILITARY, AIR CRAFT, SPACE, LIFE SAVING, OR LIFE SUSTAINING APPLICATIONS, NOR IN PRODUCTS OR SYSTEMS WHERE FAILURE OR MALFUNCTION MAY RESULT IN PERSONAL INJURY, DEATH, OR SEVERE PROPERTY OR ENVIRONMENTAL DAMAGE. ST PRODUCTS WHICH ARE NOT SPECIFIED AS "AUTOMOTIVE GRADE" MAY ONLY BE USED IN AUTOMOTIVE APPLICATIONS AT USER'S OWN RISK.

Resale of ST products with provisions different from the statements and/or technical features set forth in this document shall immediately void any warranty granted by ST for the ST product or service described herein and shall not create or extend in any manner whatsoever, any liability of ST.

ST and the ST logo are trademarks or registered trademarks of ST in various countries.

Information in this document supersedes and replaces all information previously supplied.

The ST logo is a registered trademark of STMicroelectronics. All other names are the property of their respective owners.

© 2012 STMicroelectronics - All rights reserved

STMicroelectronics group of companies

Australia - Belgium - Brazil - Canada - China - Czech Republic - Finland - France - Germany - Hong Kong - India - Israel - Italy - Japan - Malaysia - Malta - Morocco - Philippines - Singapore - Spain - Sweden - Switzerland - United Kingdom - United States of America

www.st.com