

10

9

8

7

6

5

4

3

2

SD-19218-012

NEGATIVE MATERIAL NUMBER	NEGATIVE ENGINEERING NUMBER	POSITIVE MATERIAL NUMBER	NEGATIVE ENGINEERING NUMBER	WIRE GAUGE	COLOR CRIMP	BARREL ID	BARREL OD	L +.060, -.010 (+1.52, -0.25)	W ±.020/(±0.51)	H
192180158	SBTF10N	192180160	SBTF10P	1/0	BLACK	.47/(11.9)	.65/(16.5)	2.46/(62.5)	2.20/(55.9)	.65/(16.5)
192180162	SBTF20N	192180164	SBTF20P	2/0	ORANGE	.50/(12.7)	.65/(16.5)	2.46/(62.5)	2.20/(55.9)	.65/(16.5)
192180166	SBTF30N	192180168	SBTF30P	3/0	PURPLE	.53/(13.5)	.65/(16.5)	2.46/(62.5)	2.20/(55.9)	.65/(16.5)
192180170	SBTF40N	192180172	SBTF40P	4/0	YELLOW	.63/(16.0)	.83/(21.1)	2.50/(63.5)	2.08/(52.8)	.71/(18.0)

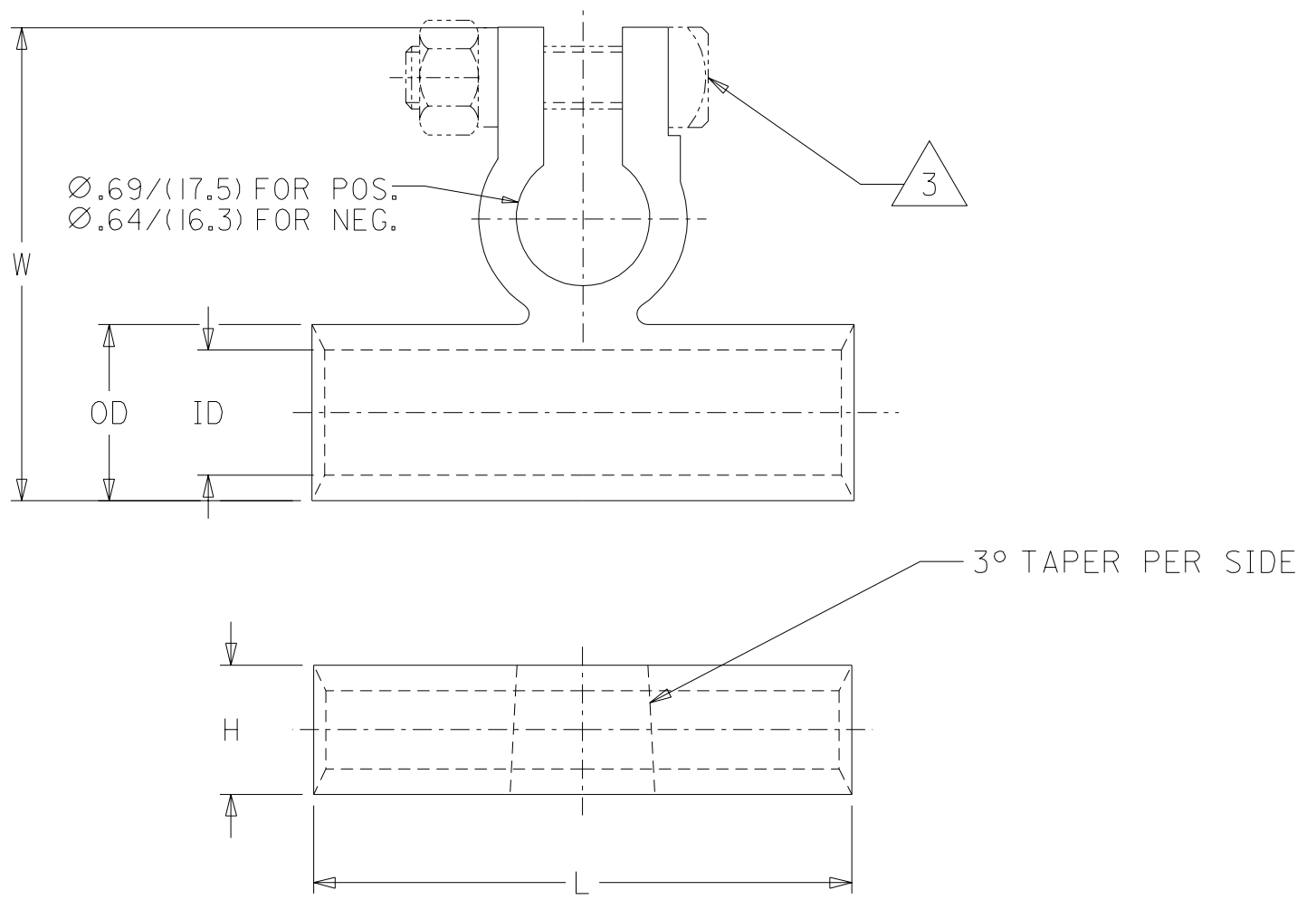

SALES DRAWING

- NOTES:
1. MATERIAL: DIE CAST COPPER.
 2. FINISH: TIN PLATED.
 3. INCLUDES 5/16 BOLT & SHOULDER NUT.

NEW RELEASE EC NO. ETC2003-0166 DRWN: BRE 03/01/10 CHK: HEB 03/01/10 APPR: RWD 03/01/10	QUALITY SYMBOLS	GENERAL TOLERANCES: (UNLESS SPECIFIED)	SCALE NO: NE	DESIGN UNITS <input type="checkbox"/> mm <input checked="" type="checkbox"/> INCH	THIRD ANGLE PROJECTION	DIMENSIONS: <input type="checkbox"/> mm <input checked="" type="checkbox"/> INCH <input type="checkbox"/> mm ONLY	SHT	REV	
	MAJOR =0	mm INCH	NO: NE	<input type="checkbox"/> mm <input checked="" type="checkbox"/> INCH	<input type="checkbox"/> mm <input checked="" type="checkbox"/> INCH				
	CRITICAL =0	4 PLACES ±0. ±.	DRAWN BY & DATE BRE 03/01/03	TITLE: DIE CAST COPPER BATTERY TERMINAL FLAG CONNECTOR					
		3 PLACES ±0. ±.	CHECKED BY & DATE HEB 03/01/03	MOLEX INCORPORATED					
	2 PLACES ±0. ±.020	APPROVED BY & DATE RWD 03/01/03	CAD FILENAME SD-19218-012 .DGN	MATERIAL NO. SEE CHART	DRAWING NO. SD-19218-012	SHEET NO. 1 OF 1			
	1 PLACE ±0.50 ±.	ANGULAR: ±1/2°	THIS DRAWING CONTAINS INFORMATION THAT IS PROPRIETARY TO MOLEX INCORPORATED AND SHOULD NOT BE USED WITHOUT WRITTEN PERMISSION.				SIZE B		
		DRAFT WHERE APPLICABLE MUST REMAIN WITHIN DIMENSIONS							

9

8

7

6

5

4

3

2

1