

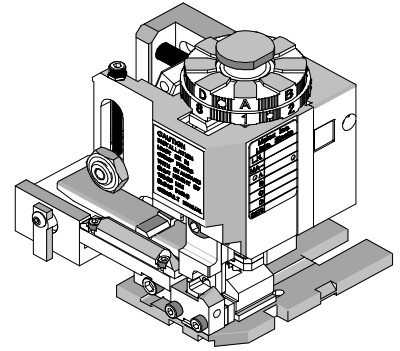

Mini-Mac Applicator Specification Sheet Part No. 63830-4000



FEATURES

- Quick set-up time; plus the crimp height, track and feed adjustments can be preset in applicator
- Conductor and insulation rings allow quick adjustment for conductor and insulation diameter change
- Applicator designed to industry standard mounting and shut height 135.80mm (5.346")
- Directly adapts to most automatic wire processing machines

SCOPE

Terminal Series No.	Wire Size		Insulation Diameter		Strip Length	
	AWG	mm ²	mm	In.	mm	In.
43178-100*	18	0.80	2.36-3.56	.093-.140	3.96-5.54	.156-.218

DEFINITION OF TERMS

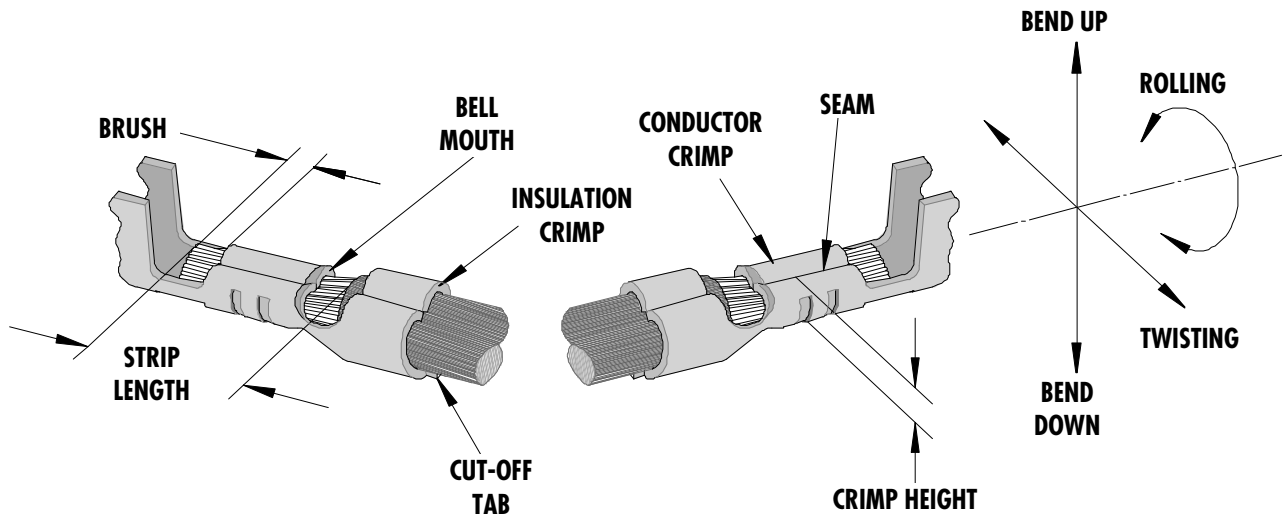

The above terminal drawing is a generic terminal representation. It is not an image of a terminal listed in the scope.

CRIMP SPECIFICATIONS

Terminal Series No.	Bell mouth		Cut-off Tab Max.		Conductor Brush	
	mm	In.	mm	In.	mm	In.
43178-100*	0.25-1.00	.010-.039	0.50	.019	1.50	.059

Terminal Series No.	Bend up Bend down		Twist Roll		Punch Width (Ref)				Seam
	Degree		Degree		Conductor		Insulation		
					mm	In	mm	In	
43178-100*	3	3	4	8	3.20	.126	4.30	.169	Seam shall not be open and no wire allowed out of the crimping area

After crimping, the conductor profile should measure the following.

Terminal Series No.	Wire Size		Crimp Height		Pull Force Min.	
	AWG	mm ²	mm	In.	N	Lb.
43178-100*	18	0.80	1.78-1.88	.070-.074	88.9	20

Pull Force should be measured with no influence from the insulation crimp.

The above specifications are guidelines to an optimum crimp.

PARTS LIST

Item	Order No	Engineering No.	Description	Quantity
	63830-4000	63830-4000	Mini-Mac Applicator	REF
1	11-18-5413	60842A106	Conductor Punch	1 Y
2	63445-3262	63445-3262	Conductor Anvil	1 Y
3	11-18-5419	60843A108	Insulation Punch	1 Y
4	63445-4322	63445-4322	Insulation Anvil	1 Y
5	63443-0047	63443-0047	Front Cut-Off Plunger	1 Y
6	63443-0012	63443-0012	Cut-off Plunger Retainer	1 Y
7	63700-0539	63700-0539	Heavy Duty Cut-off Plunger Spring	1
8	63830-3006	63830-3006	Front Plunger Striker	1
9	63443-0021	63443-0021	Lower Tooling Key	1
10	11-18-5440	60842A117	Rear Cover	1
11	11-18-5441	60842A123	Front Cover	1
12	63830-4002	63830-4002	Anvil Mount	1
13	63821-0015	63821-0015	Wire Stop	1
14	63830-3005	63830-3005	Tooling Washer	1
15	11-18-5016	60812A105	Conductor Adjusting Cam	1
16	63800-0100	63800-0100	Mini-Mac Applicator Frame	1
17	N/A	N/A	M3 by 6 Lg. SHCS	2**
18	N/A	N/A	M4 by 8 Lg. BHCS	4**
19	N/A	N/A	M4 by 10 Lg. BHCS	2**
20	N/A	N/A	M4 by 25 Lg. SHCS	2**
21	N/A	N/A	M5 by 12 Lg. SHCS	1**
22	N/A	N/A	3MM by 6 Lg. Roll Pin	1**
23	63830-4070	63830-4070	Tool Kit (All "Y" Items)	REF

** The following purchased parts are available from an Industrial supply company such as MSC (1-800-645-7270).

Assembly Drawing

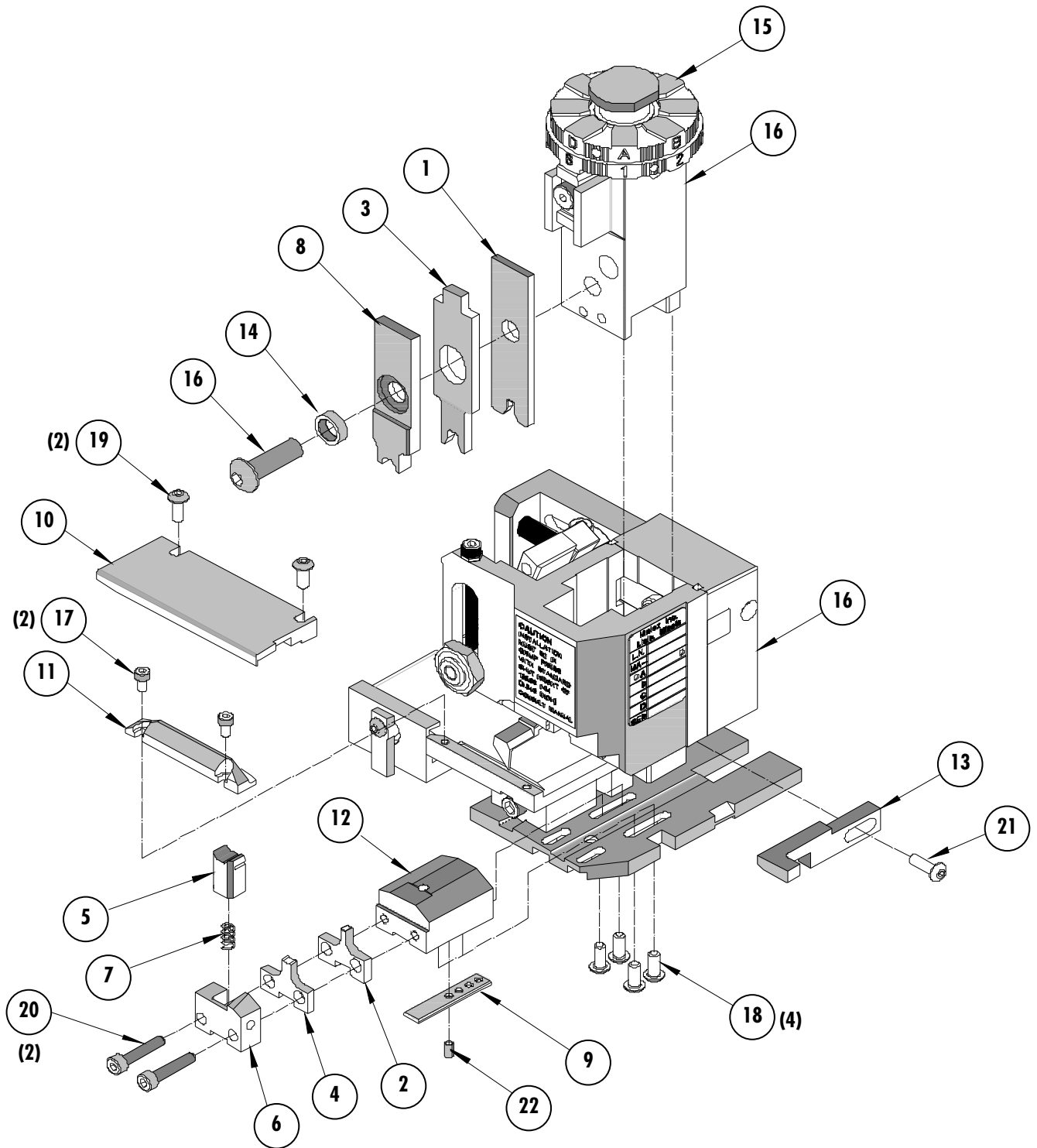

Figure 1

NOTES

1. Molex recommends an extra perishable tooling kit be maintained at your facility.
2. Verify tooling alignment by manually cycling the press and Applicator before crimping under power. Check that all screws are tight.
3. Slugs, Terminals, Dirt and Oil should be kept clear of work area.
4. Wear safety glasses at all times.
5. For recommended maintenance refer to the MiniMac Manual.

CAUTION: This applicator should only be used in a press with a shut height of 135.8 mm (5.346"). Tooling damage could result at a lower setting.

CAUTION: To prevent injury never operate this Applicator without the guards supplied with the press or wire-processing machine in place. Reference the press or wire processing manufacturer's instruction manual.

CAUTION: Molex crimp specifications are valid only when used with Molex terminals, applicators and tooling.

Molex Application Tooling Group

1150 E. Diehl Road
Naperville, IL 60563
Tel: (630) 969-4550
Fax: (630) 505-0049

Visit our Web site at <http://www.molex.com>