

REVISIONS				
ECN NO	REVISION	DATE	DESCRIPTION	CHANGER
CY10-5701	B	OCT 12,09	UPDATE BOM	JOE XIE

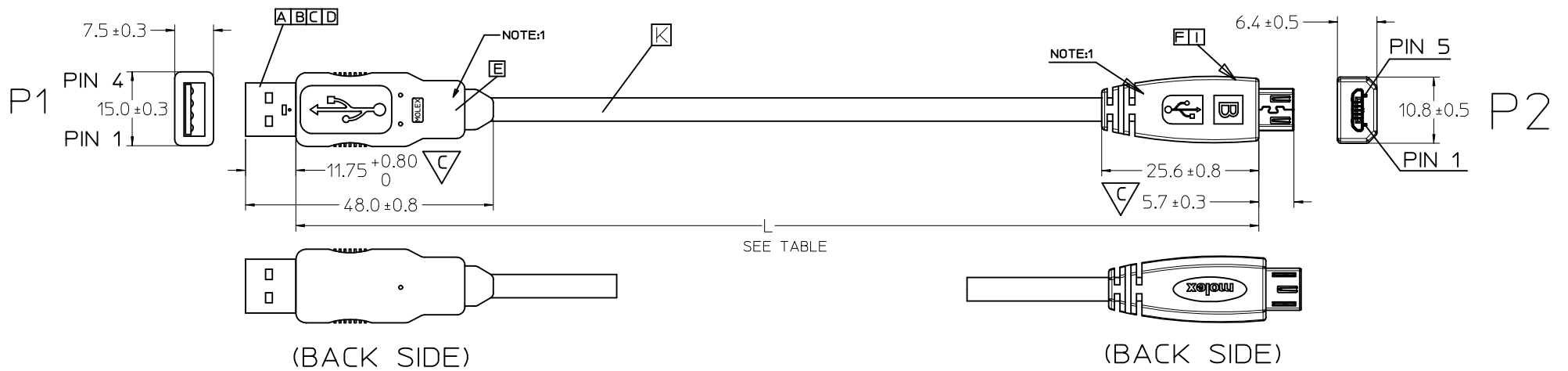

TABLE:

ITEM	MATERIAL NO.	DESCRIPTION	L
1	687840001	USB A TO MICRO B CABLE ASSY	1000±20
2	687840002	USB A TO MICRO B CABLE ASSY	1500±30
3	687840003	USB A TO MICRO B CABLE ASSY	2000±40

NOTE:

- OVERMOLD SPECIFICATION:
OUTER MOLDER WITH PVC RESIN
INNER MOLDER WITH PE RESIN
- THIS PRODUCT ELECTRICAL PERFORMANCE MUST MEET 2.0 COMPLIANCE.
- THIS PRODUCT MUST MEET ROHS COMPLIANCE.

SHELL	BRAID WIRE	SHELL
4	28AWG BLACK	5
3	28AWG GREEN	3
2	28AWG WHITE	2
1	28AWG RED	1
P1	Wire Color	P2
	PIN ASSIGNMENTS	

ITEM	DESCRIPTION	L(REF)	QTY.
K	USB2.0 1P*28AWG+2C*28AWG		
I	COPPER FOIL		1
F	MICRO USB PLUG B		1
E	COPPER FOIL		1
D	TERMINAL (AWG26/28)		4
C	REAR SHELL		1
B	FRONT SHELL		1
A	CRIMP HOUSING		1

ENTER DESCRIPTION EC NO: DG2011-0455 DRW: ZHANG01 2011/05/27 CHK: CHRIS 2011/05/27 APPR: ZXDENG 2011/05/27	QUALITY SYMBOLS ▽=0 ▽=2	GENERAL TOLERANCES (UNLESS SPECIFIED)		DIMENSION STYLE MM ONLY		SCALE ---	DESIGN UNITS METRIC	THIRD ANGLE PROJECTION	
		4 PLACES ±--- ±--- 3 PLACES ±--- ±--- 2 PLACES ±--- ±--- 1 PLACE ±--- ±---	mm INCH ±--- ±--- ±--- ±--- ±--- ±--- ±--- ±---	DRAWN BY JTHUANG	DATE 08-09-30	TITLE USB A PLUG TO MICRO B PLUG CABLE ASSY			
		ANGULAR ±---°		CHECKED BY BENTZ, LIU	DATE 08-09-30	MATERIAL NO. SEE TABLE			
		DRAFT WHERE APPLICABLE MUST REMAIN WITHIN DIMENSIONS		APPROVED BY ZXDENG	DATE 2011/05/27	MOLEX INCORPORATED		DOCUMENT NO. SD-68784-001	SHEET NO. 1 OF 1