

COMM

User Manual

HSMC Communication Card

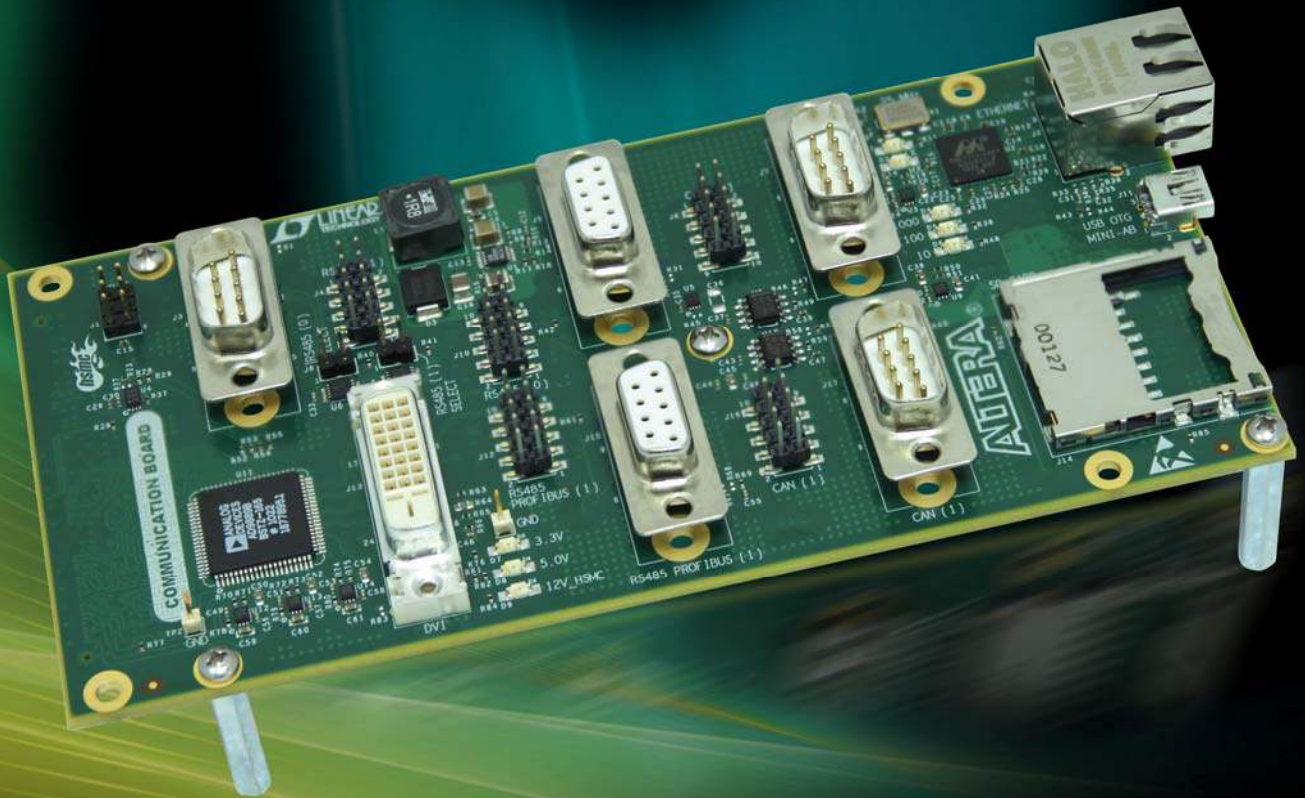

terasic
www.terasic.com

ALTERA

Chapter 1	Introduction	3
1.1	Features	3
1.2	Getting Help	4
Chapter 2	Architecture	5
2.1	Block Diagram	6
Chapter 3	Pin Description	7
3.1	HSMC Expansion Connector	7
Chapter 4	Components	14
4.1	RGMII Ethernet PHY	14
4.2	USB 2.0 OTG PHY	16
4.3	RS-485/RS-232 Interface	17
4.4	CAN Interface	21
4.5	GPIO Interface	21
4.6	DVI Output	22
4.7	SD/SDIO/MMC reader	24
4.8	EEPROM	25
4.9	Power	25
Chapter 5	Appendix	27
5.1	Revision History	27
5.2	Copyright Statement	27

Chapter 1

Introduction

The HSMC Communication card adds key interfaces to support a wide range of industrial, image processing, scientific and measurement requirements. From 10/100/1000 Ethernet PHY, to CAN, RS232, RS485, the HSMC Communication card can quickly get you started with your designs. Also included is a digital DVI transmitter port to display FPGA driven video content. The card allows users to evaluate included interfaces with any HSMC interface host boards.

1.1 Features

Figure 1-1 shows the photo of the HSMC Communication card. The important features are listed below:

- RGMII Ethernet PHY, RJ-45 connector
- USB 2.0 OTG PHY with ULPI
- RS-485 x2 with 2x5 0.1" header
- CAN x2 with DB9 connector
- GPIO with 2x3 0.1" connector
- SD Card Socket
- DVI Transmitter with DVI-D Connector
- HSMC identification is facilitated via the on board I2C EEPROM.



Figure 1-1 Picture of the HSMC Communication card

1.2 Getting Help

Here are some places to get help if you encounter any problem:

- Email to support@terasic.com
- Taiwan & China: +886-3-550-8800
- Korea : +82-2-512-7661
- Japan: +81-428-77-7000

This chapter describes the architecture of the HSMC Communication card including block diagram and components.

A photograph of the HSMC Communication card is shown in **Figure 2-1** and **Figure 2-2**. It depicts the layout of the board and indicates the location of the connectors and key components.

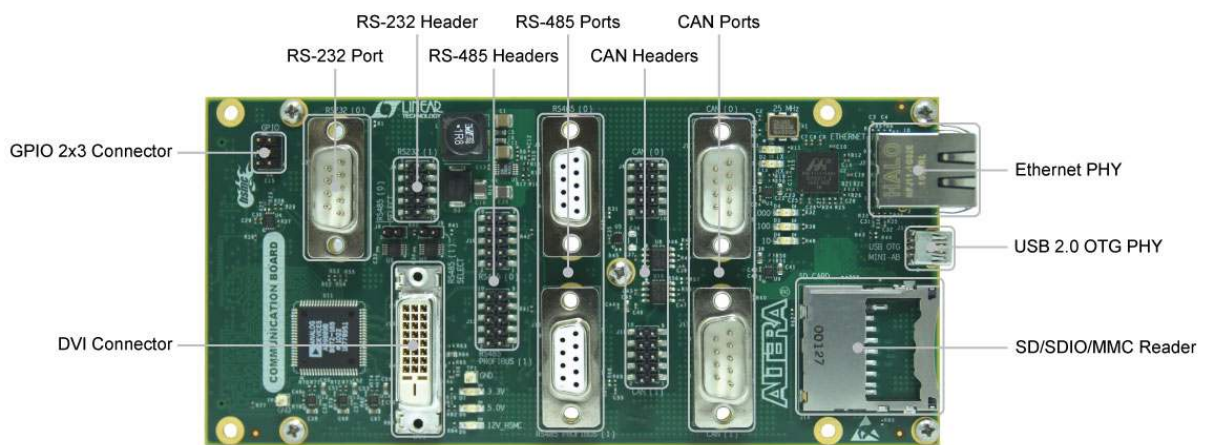

Figure 2-1 The HSMC Communication PCB and component diagram



Figure 2-2 The HSMC Communication card back side

2.1 Block Diagram

Figure 2-3 shows the block diagram of the HSMC Communication card.

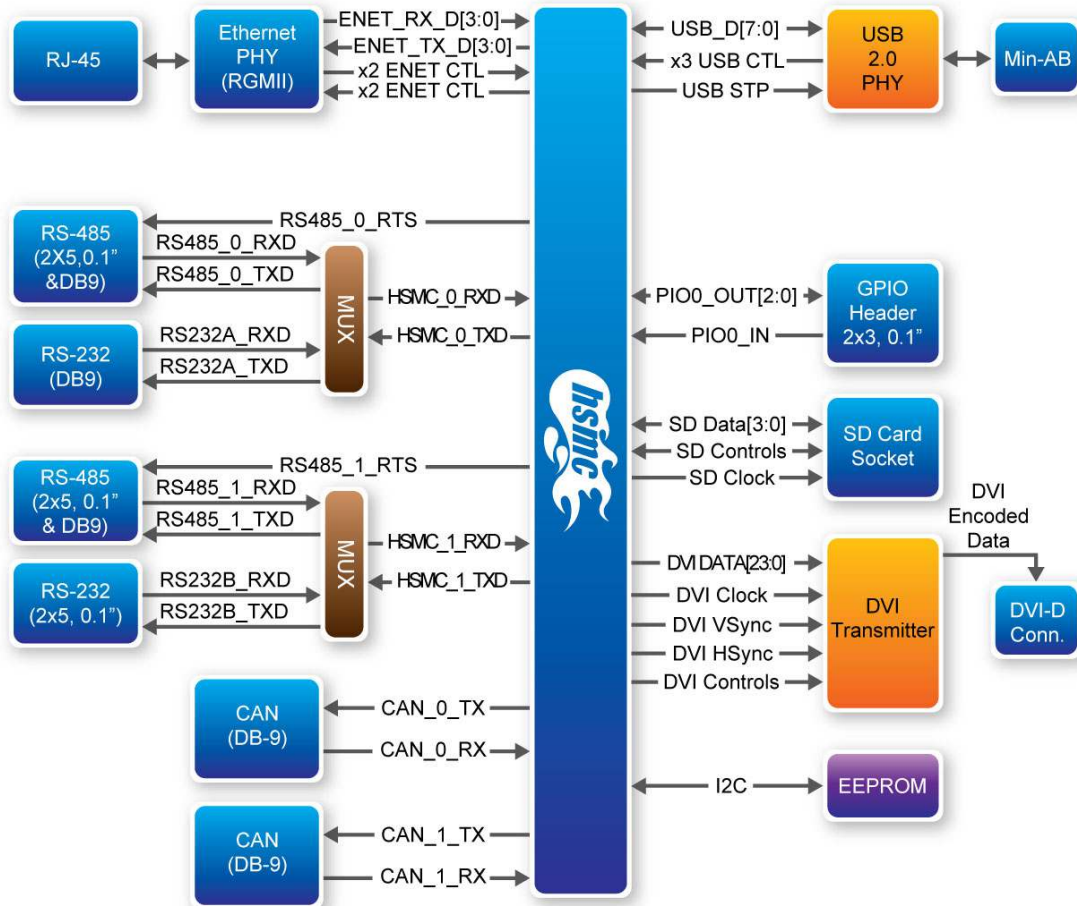

Figure 2-3 Block diagram of the HSMC Communication card

Chapter 3

Pin Description

This chapter describes the detailed information of the connector interfaces, and the pin description on the HSMC Communication card.

3.1 HSMC Expansion Connector

The HSMC Communication card contains a HSMC connector. **Figure 3-1**, **Figure 3-2** and **Figure 3-3** show the pin-outs of the HSMC connector on the Mass Storage and Video card.

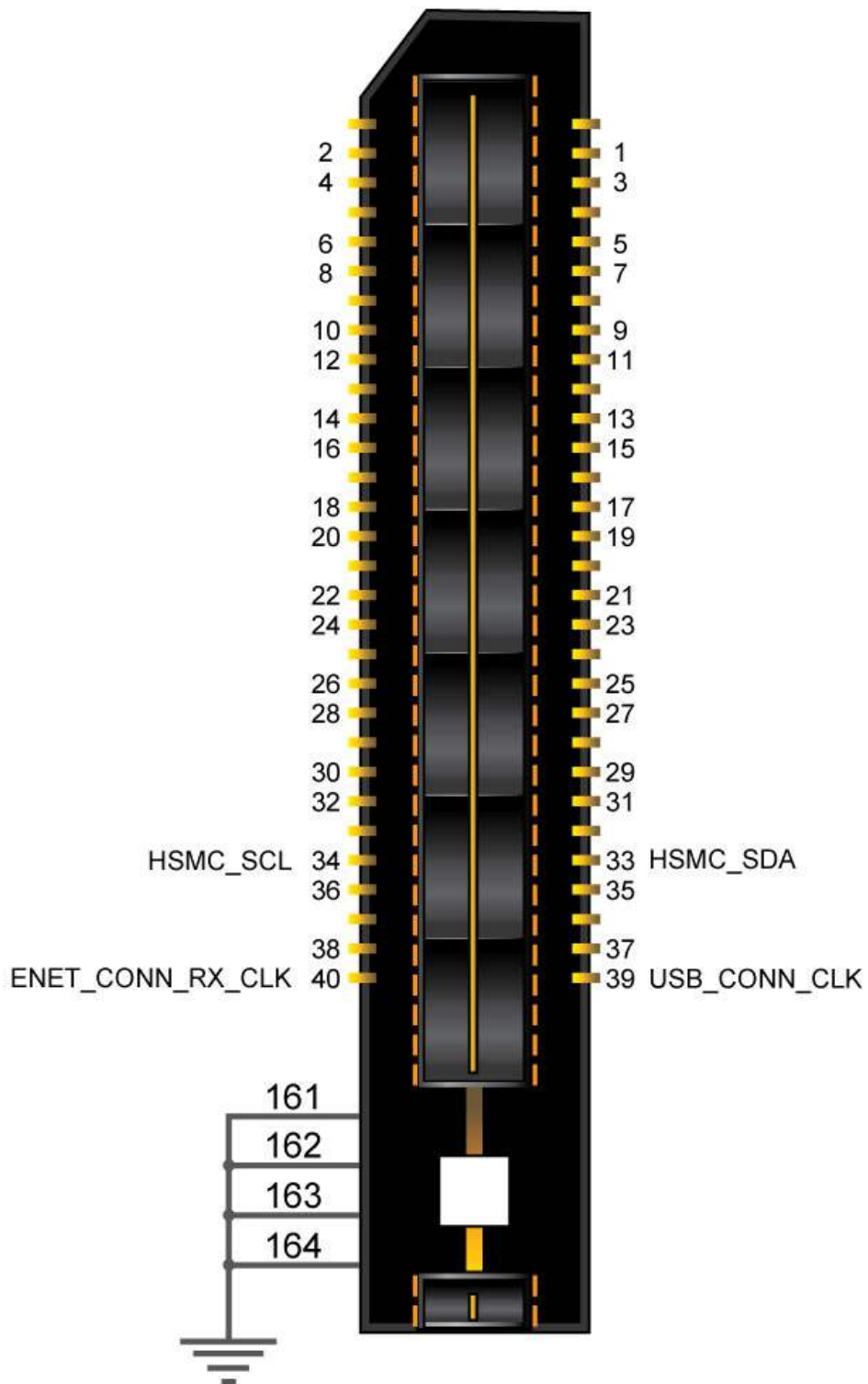

Figure 3-1 Pin-outs of Bank 1 on the HSMC connector

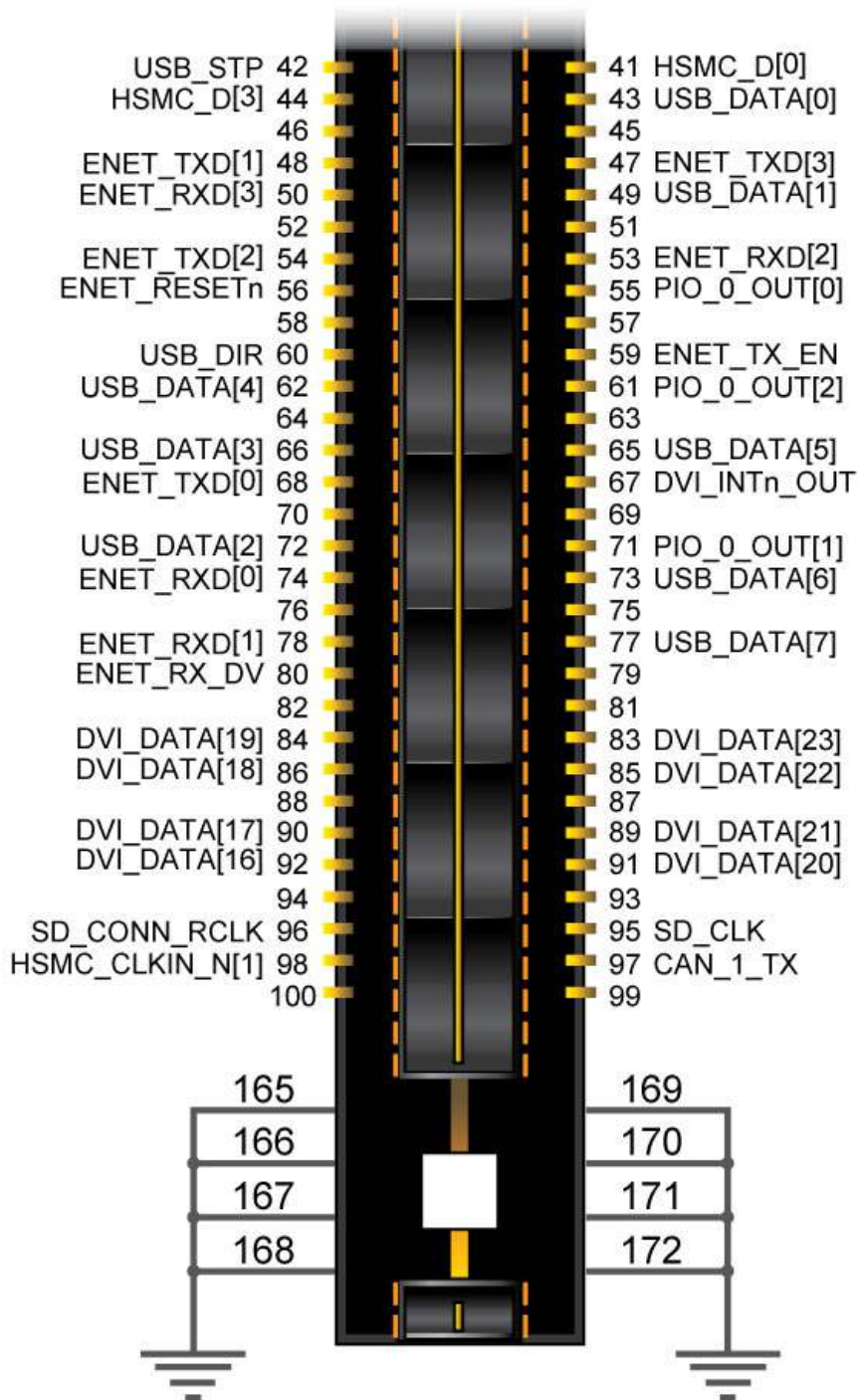

Figure 3-2 Pin-outs of Bank 2 on the HSMC connector

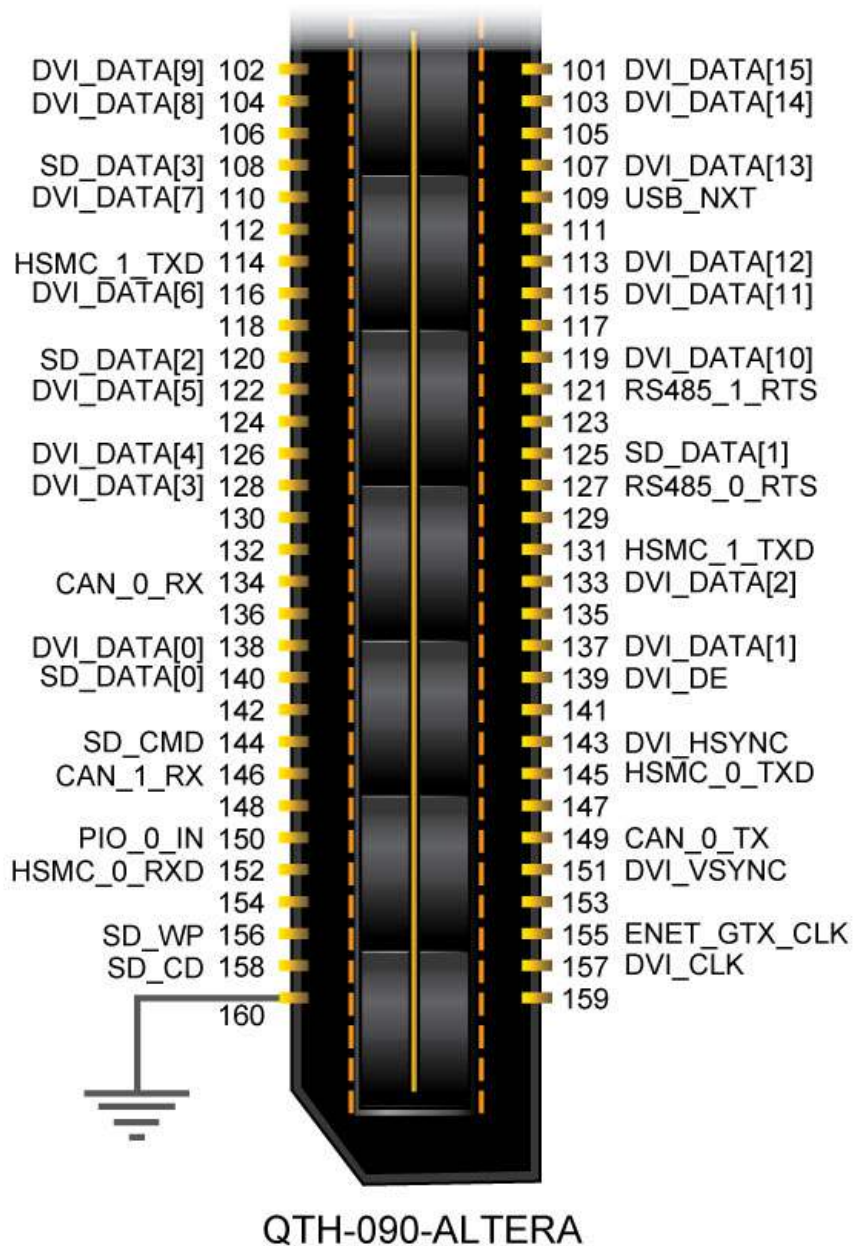

Figure 3-3 Pin-outs of Bank 3 on the HSMC connector

Table 3-1 shows the pin description of the HSMC connector.

Table 3-1 The pin mappings of the HSMC connector

<i>HSMC Expansion Connector</i>			
Pin Number	Signal Name	Direction	Function
134	CAN_0_RX	Output	CAN Receive Data Output
149	CAN_0_TX	Input	CAN Transmit Data Input
146	CAN_1_RX	Output	CAN Receive Data Output
97	CAN_1_TX	Input	CAN Transmit Data Input
157	DVI_CLK	Input	DVI Transmitter CLK
138	DVI_DATA[0]	Input	DVI Transmitter Data Bit 0
137	DVI_DATA[1]	Input	DVI Transmitter Data Bit 1
119	DVI_DATA[10]	Input	DVI Transmitter Data Bit 10
115	DVI_DATA[11]	Input	DVI Transmitter Data Bit 11
113	DVI_DATA[12]	Input	DVI Transmitter Data Bit 12
107	DVI_DATA[13]	Input	DVI Transmitter Data Bit 13
103	DVI_DATA[14]	Input	DVI Transmitter Data Bit 14
101	DVI_DATA[15]	Input	DVI Transmitter Data Bit 15
92	DVI_DATA[16]	Input	DVI Transmitter Data Bit 16
90	DVI_DATA[17]	Input	DVI Transmitter Data Bit 17
86	DVI_DATA[18]	Input	DVI Transmitter Data Bit 18
84	DVI_DATA[19]	Input	DVI Transmitter Data Bit 19
133	DVI_DATA[2]	Input	DVI Transmitter Data Bit 2
91	DVI_DATA[20]	Input	DVI Transmitter Data Bit 20
89	DVI_DATA[21]	Input	DVI Transmitter Data Bit 21
85	DVI_DATA[22]	Input	DVI Transmitter Data Bit 22
83	DVI_DATA[23]	Input	DVI Transmitter Data Bit 23
128	DVI_DATA[3]	Input	DVI Transmitter Data Bit 3
126	DVI_DATA[4]	Input	DVI Transmitter Data Bit 4
122	DVI_DATA[5]	Input	DVI Transmitter Data Bit 5
116	DVI_DATA[6]	Input	DVI Transmitter Data Bit 6
110	DVI_DATA[7]	Input	DVI Transmitter Data Bit 7
104	DVI_DATA[8]	Input	DVI Transmitter Data Bit 8
102	DVI_DATA[9]	Input	DVI Transmitter Data Bit 9
139	DVI_DE	Input	DVI Transmitter Data Valid
143	DVI_HSYNC	Input	DVI Transmitter HSYNC
67	DVI_INTn_OUT	Output	DVI Transmitter VSYNC
151	DVI_VSYNC	Input	RGMIIC Receive Clock
40	ENET_CONN_RX_CLK	Output	RGMIIC Transmit Clock
155	ENET_GTX_CLK	Input	Management Interrupt
98	ENET_INTn	Output	Management Data Clock
41	ENET_MDC	Input	Management Data
44	ENET_MDIO	Bi-directional	Ethernet Hardware Reset
56	ENET_RESETh	Input	RGMIIC Receive Control

80	ENET_RX_DV	Output	RGMII Receive Data bit 0
74	ENET_RXD[0]	Output	RGMII Receive Data bit 1
78	ENET_RXD[1]	Output	RGMII Receive Data bit 2
53	ENET_RXD[2]	Output	RGMII Receive Data bit 3
50	ENET_RXD[3]	Output	RGMII Transmit Control
59	ENET_TX_EN	Input	RGMII Transmit Data bit 0
68	ENET_TXD[0]	Input	RGMII Transmit Data bit 1
48	ENET_TXD[1]	Input	RGMII Transmit Data bit 2
54	ENET_TXD[2]	Input	RGMII Transmit Data bit 3
47	ENET_TXD[3]	Input	RS-485/RS-232 Receive Data
152	HSMC_0_RXD	Output	RS-485/RS-232 Transmit
145	HSMC_0_TXD	Input	RS-485/RS-232 Receive
114	HSMC_1_RXD	Output	RS-485/RS-232 Transmit
131	HSMC_1_TXD	Input	EEPROM Serial Clock
34	HSMC_SCL	Input	EEPROM Serial Address/
33	HSMC_SDA	Bi-directional	GPIO Input Data
150	PIO_0_IN	Output	GPIO Bi-directional Data
55	PIO_0_OUT[0]	Bi-directional	GPIO Bi-directional Data
71	PIO_0_OUT[1]	Bi-directional	GPIO Bi-directional Data
61	PIO_0_OUT[2]	Bi-directional	RS-485 Request to Send
127	RS485_0_RTS	Input	RS-485 Request to Send
121	RS485_1_RTS	Input	SD Card Detection
158	SD_CD	Output	SD Card Reader Clock
95	SD_CLK	Input	SD Card Reader Command
144	SD_CMD	Bi-directional	SD Card Reader Readback
96	SD_CONN_RCLK	Output	from Level Translator
140	SD_DATA[0]	Bi-directional	SD Card Reader Data Bit
125	SD_DATA[1]	Bi-directional	SD Card Reader Data Bit
120	SD_DATA[2]	Bi-directional	SD Card Reader Data Bit
108	SD_DATA[3]	Bi-directional	SD Card Reader Data Bit
156	SD_WP	Output	SD Card Write Protect
39	USB_CONN_CLK	Output	USB 60MHz Reference
43	USB_DATA[0]	Bi-directional	USB Data bit 0
49	USB_DATA[1]	Bi-directional	USB Data bit 1
72	USB_DATA[2]	Bi-directional	USB Data bit 2
66	USB_DATA[3]	Bi-directional	USB Data bit 3
62	USB_DATA[4]	Bi-directional	USB Data bit 4
65	USB_DATA[5]	Bi-directional	USB Data bit 5
73	USB_DATA[6]	Bi-directional	USB Data bit 6
77	USB_DATA[7]	Bi-directional	USB Data bit 7
60	USB_DIR	Output	USB Data Direction
109	USB_NXT	Output	USB NXT

42	USB_STP	Input	USB STP
132	-	-	-
79	-	-	-

Table 3-2 below outlines HSMC power levels that host boards guarantee from on-board power supplies (minimum) according to the HSMC specification. These power rails will be delivered via designated pins on the HSMC connector.

Table 3-2 HSMC Power Levels

<i>Voltage</i>	<i>Current Rating</i>	<i>WAX Wattage</i>
12V	1.0A	12.0W
3.3V_HSMC	2.0A	6.6W
Total		18.6W

Components

This chapter gives a simple description of the on board components, such as operational mode, signaling standard. For more detailed information you could refer to its datasheet which is available on manufacturer’s website or from our provided system CD.

4.1 RGMII Ethernet PHY

This card supports copper RJ-45 10/100/1000 base-T Ethernet using an external Marvell 88E1111. The PHY-to-MAC interface employs an RGMII interface. A block diagram is shown in **Figure 4-1** where the MAC is found in the FPGA.

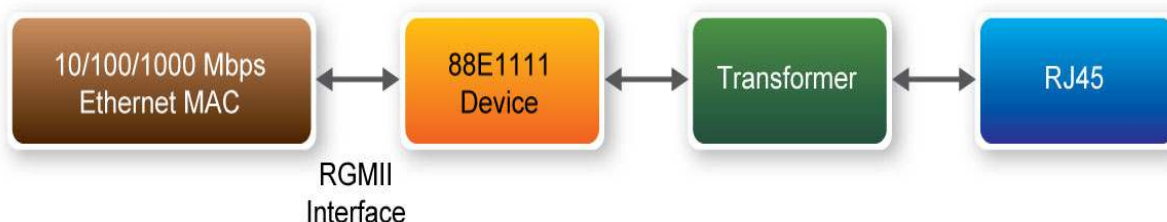

Figure 4-1 Marvell RGMII Diagram

This device uses 2.5V and 1.1V power rails and requires a 25MHz reference clock (+/-50ppm tolerance) to be driven from a dedicated oscillator. It interfaces to a HALO HFJ11-1G02E model RJ-45 with internal magnetics. The bootstrapping pins are wired to default to “RGMII to copper mode” (HWCFG_MODE[3:0] = 1011). The table below summarizes the pins of the 10/100/1000 Ethernet interface. Signal names and directions are relative to the host board.

Table 4-1 Ethernet PHY Interface I/O

Signal Name	Description	Type
ENET_GTX_CLK	125MHz GMII Transmit Clock	2.5V CMOS output
ENET_TX_CLK	25MHz MII Transmit Clock	n/a
ENET_TX_ER	GMII Transmit Error	n/a (tie to GND)

ENET_TX_EN	GMII Transmit Enable	2.5V CMOS output
ENET_TXD(7:4)	GMII Transmit Data Bus	GND
ENET_TXD(3:0)	RGMII Transmit Data Bus	2.5V CMOS output
ENET_RX_CLK	GMII Receive Clock	2.5V CMOS input
ENET_RX_ER	GMII Receive Error	n/a
ENET_RX_DV	RGMII Receive Control	2.5V CMOS input
ENET_RXD(7:4)	GMII Receive Data Bus	n/a
ENET_RXD(3:0)	RGMII Receive Data Bus	2.5V CMOS input
ENET_CR_S	GMII Carrier Sense	n/a
ENET_COL	GMII Collision	n/a
ENET_RESE _{Tn}	Reset	2.5V CMOS input
ENET_MDC	Management Bus Data Clock	2.5V CMOS input
ENET_MDIO	Management Bus Data	2.5V CMOS input
ENET_INT _n	Management Bus Interrupt	2.5V CMOS input
ENET_MDI(3:0) _{p/n}	Media Dependent Interface	n/a (to RJ-45 and transformers)
ENET_S_CLK _{p/n}	SGMII 625MHz Clock	n/a
ENET_S_OUT _{p/n}	SGMII Receive Data	n/a
ENET_S_IN _{p/n}	SGMII Receive Data	n/a
ENET_LED_LINK10	10Mb Link LED	n/a (driven to LED)
ENET_LED_LINK100	100Mb Link LED	n/a (driven to LED)
ENET_LED_LINK1000	1000Mb Link LED	n/a (driven to LED)
ENET_LED_DUPLEX	Duplex/Collision LED	n/a
ENET_LED_RX	RX Data Active LED	n/a (driven to LED)
ENET_LED_TX	TX Data Active LED	n/a (driven to LED)
TMS	JTAG Mode Select	n/a
TCK	JTAG Clock	n/a
TDO	JTAG Data Out	n/a
TDI	JTAG Data In	n/a
TRST _n	JTAG Reset	Pull to GND with 4.7k _Ω
CONFIG0	Mode configuration pin 0	n/a (tie to GND)
CONFIG1	Mode configuration pin 1	n/a (tie to GND)
CONFIG2	Mode configuration pin 2	n/a (tie to 2.5V)
CONFIG3	Mode configuration pin 3	n/a (tie to GND)
CONFIG4	Mode configuration pin 4	n/a (tie to LED_DUPLEX)
CONFIG5	Mode configuration pin 5	n/a (tie to LED_LINK100)
CONFIG6	Mode configuration pin 6	n/a (tie to LED_RX)

VDDO	I/O Power Pin	2.5V
VDDH	I/O Power Pin	2.5V
VDDX	I/O Power Pin	2.5V
AVDD	Analog Power Input	2.5V
DVDD	Digital Power Input	1.2V
GND	-	Ground

Ethernet PHY

The 88E1111 uses a multi-level bootstrap encoding scheme to allow a small set of pins (7) to set up a very large number of default settings within the device. The level encoding scheme is shown in the table below from the Marvel datasheet. The CONFIG[6:0] signals should be tied directly to VDDO, GND or the defined Ethernet pin as described below.

Table 4-2 Ethernet PHY Bootstrap Encoding

<i>Pin</i>	<i>Bit[2:0]</i>
VDDO	111
LED_LINK10	110
LED_LINK100	101
LED_LINK1000	100
LED_DUPLEX	011
LED_RX	010
LED_TX	001
VSS	000

Table 4-3 Ethernet PHY Bootstrap Settings

<i>Pin</i>	<i>Pin Connection</i>	<i>Setting</i>	<i>Definition</i>
CONFIG0	GND	000	MDIO PHY Address bit (2:0) = 000
CONFIG1	GND	000	Enable Pause = 0, PHY Address bits (4:3) = 00
CONFIG2	VDDO (2.5V)	111	Auto-negotiate, advertise all capabilities, prefer
CONFIG3	GND	000	Disable crossover, disable CLK125
CONFIG4	LED_DUPLEX	011	Hardware Config Mode Reg (2:0) = 011
CONFIG5	LED_LINK100	101	Disable fiber/copper autosel, enable sleep mode
CONFIG6	LED_RX	010	(enable energy detect), Hardware Config Mode

4.2 USB 2.0 OTG PHY

The USB 2.0 PHY interface supports the On-The-Go (OTG) protocol and is pinned out with UTMI+Low Pin Interface (ULPI). The USB transceiver will be routed to a mini-AB type connector.

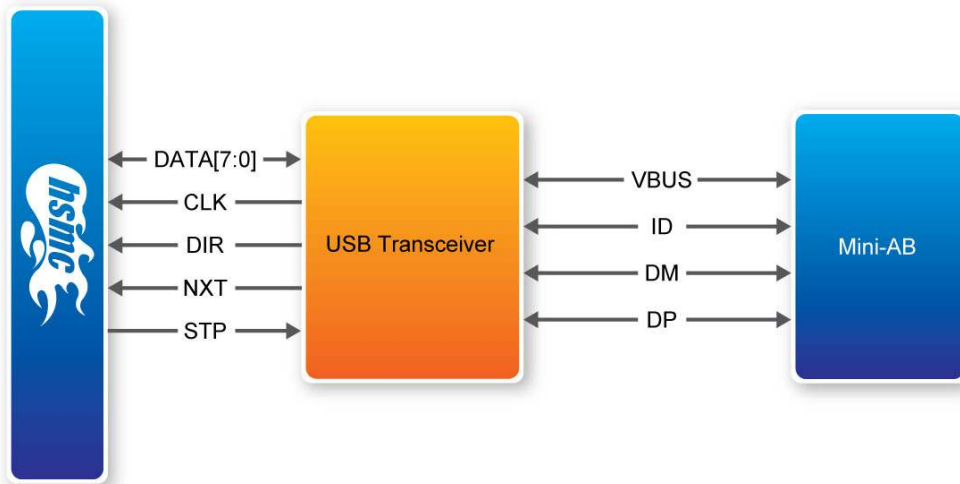

Figure 4-2 USB 2.0 Block Diagram

4.3 RS-485/RS-232 Interface

There are two multiplexer circuit allowing the ability to switch between an RS-232 or RS-485 interface. This interface contains two independent RS-485 ports and two independent RS-232 ports. Each RS-485 interface is routed to a 2x5 0.1” header and a DB-9 female connector. One RS-232 interface is routed to a 2x5 0.1” header and the second RS-232 interface is routed to a DB-9 male connector. A jumper is used on the board to select between RS-485 port 0 or RS-232 port 0 and RS-485 port 1 or RS-232 port 1.

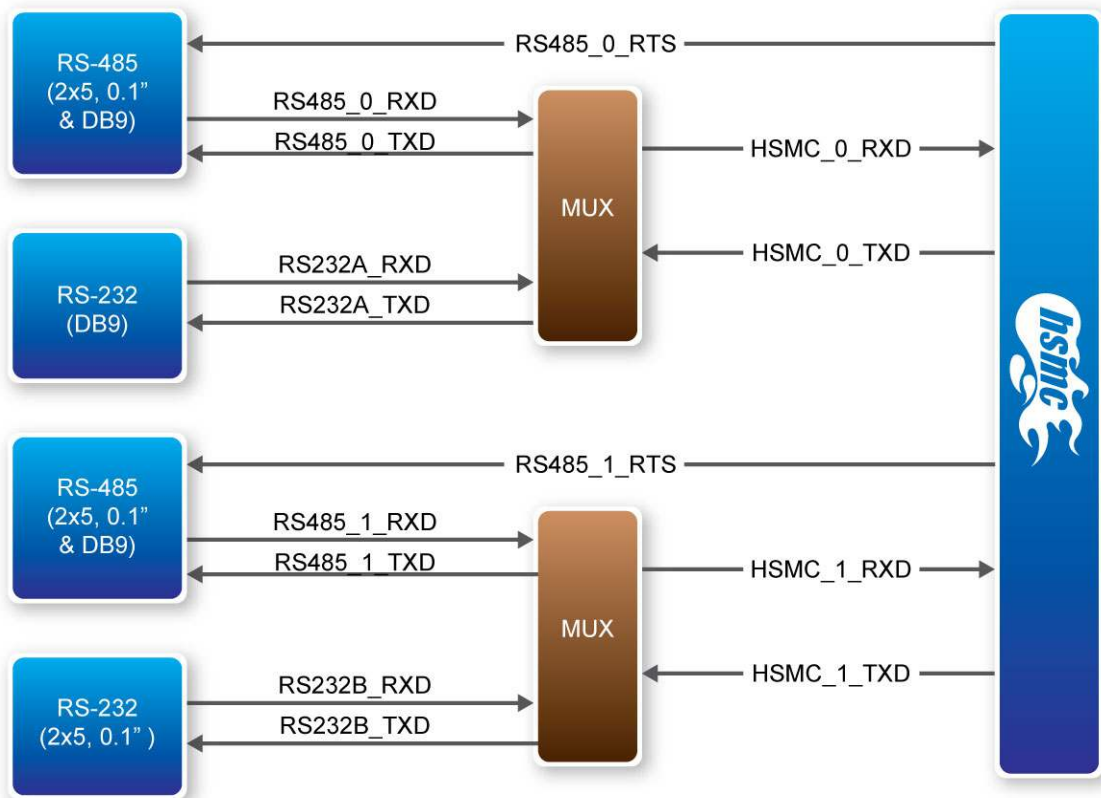

Figure 4-3 RS-485/RS-232 Interface Block Diagram

RS-485 port 0 is connected to the 2x5 header and DB-9 connector as described in the table below, pin-out and signal description are relative to the header:

Table 4-4 RS485 Port 0 Interface Connector Pin-out

<i>Pin 2x5</i>	<i>Name</i>	<i>Direction</i>	<i>Description</i>
1	NC	-	Not Connected
2	5.0V	Power	5V
3	NC	-	Not Connected
4	NC	-	Not Connected
5	B	Bidirectional	inverting driver output/receiver input.
6	A	Bidirectional	Non-inverting driver output/receiver input.
7	DE	Input	Driver Enable
8	NC	-	Not Connected
9	GND	Power	Signal Ground
10	NC	-	Not Connected

<i>Pin DB9</i>	<i>Name</i>	<i>Direction</i>	<i>Description</i>
1	GND	Power	Signal Ground
2	NC	-	Not Connected
3	B	Bidirectional	inverting driver output/receiver input.
4	DE	Input	Driver Enable
5	GND	Power	Signal Ground
6	5.0V	Power	5V
7	NC	-	Not Connected
8	A	Bidirectional	Non-Inverting driver output/receiver input.
9	-	-	-

RS-485 port 1 is a profibus type connection. It is connected to the 2x5 header and DB-9 connector as described in the table below, pin-out and signal description are relative to the header:

Table 4-5 RS485 (profibus) Port 1 Interface Connector Pin-out

<i>Pin 2x5</i>	<i>Name</i>	<i>Direction</i>	<i>Description</i>
1	NC	-	Not Connected
2	5.0V	Power	5V
3	NC	-	Not Connected
4	NC	-	Not Connected
5	A	Bidirectional	Non-inverting driver output/receiver input.
6	B	Bidirectional	Inverting driver output/receiver input.
7	DE	Input	Driver Enable
8	NC	-	Not Connected
9	GND	Power	Signal Ground
10	NC	-	Not Connected -
<i>Pin DB9</i>	<i>Name</i>	<i>Direction</i>	<i>Description</i>
1	GND	Power	Signal Ground
2	NC	-	Not Connected
3	A	Bidirectional	Non-inverting driver output/receiver input.
4	DE	Input	Driver Enable
5	GND	Power	Signal Ground
6	5.0V	Power	5V
7	NC	-	Not Connected
8	B	Bidirectional	Inverting driver output/receiver input.
9	-	-	-

RS-232 port 0 is routed to the DB-9 connector as described in **Table 4-6** below, pin-out and signal description are relative to the connector:

Table 4-6 RS232 Port 0 Interface Connector Pin-out

<i>Pin DB9</i>	<i>Name</i>	<i>Direction</i>	<i>Description</i>
1	NC	-	Not Connected
2	RXD	Output	Receive Data Line
3	TXD	Input	Transmit Data Line
4	NC	-	Not Connected
5	GND	Power	Signal Ground
6	NC	-	Not Connected
7	NC	-	Not Connected
8	NC	-	Not Connected
9	NC	-	Not Connected

RS-232 port 1 is routed to the 2x5 header as described in the table below, pin-out and signal description are relative to the connector:

Table 4-7 RS232 Port 1 Interface Connector Pin-out

<i>Pin DB9</i>	<i>Name</i>	<i>Direction</i>	<i>Description</i>
1	NC	-	Not Connected
2	NC	-	Not Connected
3	RXD	Output	Receive Data Line
4	NC	-	Not Connected
5	TXD	Input	Transmit Data Line
6	NC	-	Not Connected
7	NC	-	Not Connected
8	NC	-	Not Connected
9	GND	Power	Signal Ground
10	NC	-	Not Connected

4.4 CAN Interface

There are two CAN interfaces from the HSMC to two DB9 male connectors.

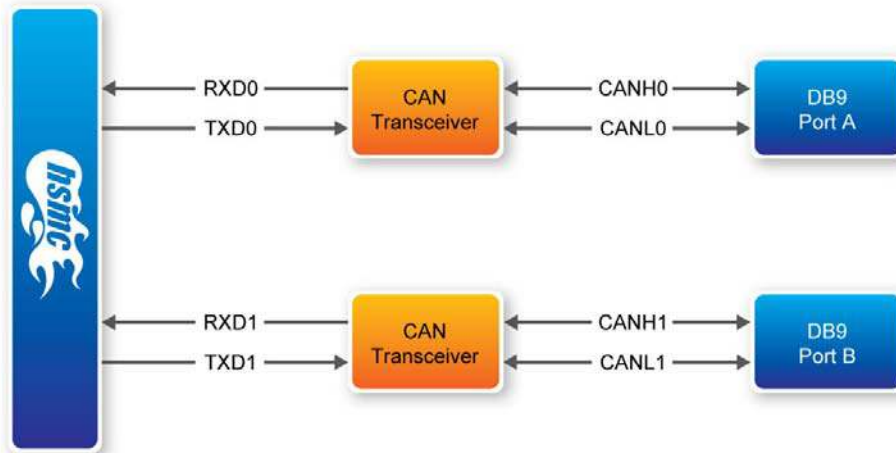

Figure 4-4 CAN Interface Block Diagram

Both CAN circuits are connected the same.

Table 4-8 CAN DB9 Connector Pin-out

<i>Pin DB9</i>	<i>Name</i>	<i>Direction</i>	<i>Description</i>
1	NC	-	Not Connected
2	CANL	2	CAN bus line low
3	GND	Power	Signal Ground
4	NC	-	Not Connected
5	GND	Power	Signal Ground
6	GND	Power	Signal Ground
7	CANH	7	CAN bus line high
8	NC	-	Not Connected
9	NC	-	Not Connected

4.5 GPIO Interface

There is one 2x3 0.1” header for a GPIO interface. This interface contains 4 single ended lines that can be used for general purpose I/O. However there are some limitations on the IO direction. GPIO_Out lines can be used for bi-directional signals, however GPIO_Input can only be used as a host board input signal.

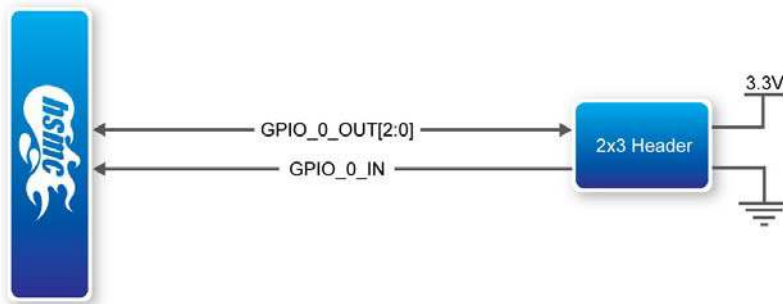

Figure 4-5 GPIO Interface Block Diagram

The GPIO head contains 6 pins with the following pin-out:

Table 4-9 GPIO Header Pin-out

Pin	Name	Direction	Description
1	GPIO_In	Input	GPIO Input
2	GPIO_Out[0]	Bi-Dir	GPIO Bi-directional 0
3	GPIO_Out[1]	Bi-Dir	GPIO Bi-directional 1
4	GPIO_Out[2]	Bi-Dir	GPIO Bi-directional 2
5	+3.3V	-	3.3V Power
6	GND	-	Ground

4.6 DVI Output

DVI Output will be able to support standard DVI-D interface, targeting UXGA resolution, that implies pixel rate of 165MHz. The block diagram is presented on the next figure:

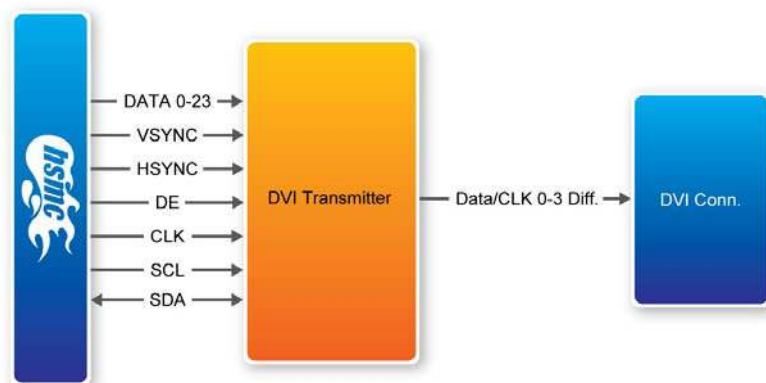

*I2C can be shared with other devices

Figure 4-6 DVI Interface Block Diagram

The purpose of DVI transmitter is to arrange the inbound pixels and generic sync signals to be compatible with DVI interface standard and transmit the encoded data over 4 differential lanes. These lanes are routed to standard DVI connector so it can be connected to imaging device with standard cable. The image data is loaded to transmitter through HSMC interface accompanied by required line and field synchronization signals.

Transmitter has I2C port that is used for configuration and diagnostic tasks and it can be shared with other on board I2C enabled devices. In addition this interface is used to communicate with DDC enabled monitors.

Here is the pin description of DVI connector:

Table 4-10 DVI Connector Pin-out

<i>Pin</i>	<i>Name</i>	<i>Direction</i>	<i>Description</i>
1	TMDS Data2-	Out	Digital red -
2	TMDS Data2+	Out	Digital red +
3	TMDS Data2/4 Shield	-	shield
4	TMDS Data4-	Out	Not in use
5	TMDS Data4+	Out	Not in use
6	SCL	Out	DDC channel clock
7	SDA	Bidir	DDC channel data
8	Analog vertical sync	Out	Not in use
9	TMDS Data1-	Out	Digital green -
10	TMDS Data1+	Out	Digital green +
11	TMDS Data1/3 Shield	-	shield
12	TMDS Data3-	Out	Not in use
13	TMDS Data3+	Out	Not in use
14	+5V	Power	Power for monitor during stand-by
15	Ground	Power	Return for +5V (pin 14)
16	Hot plug detect	In	Hot plug detect
17	TMDS Data0-	Out	Digital blue -
18	TMDS Data0+	Out	Digital blue +
19	TMDS Data0/5 Shield	-	shield
20	TMDS Data5-	Out	Not in use
21	TMDS Data5+	Out	Not in use
22	TMDS Clock Shield	-	shield
23	TMDS Clock+	Out	Digital clock -
24	TMDS Clock-	Out	Digital clock +
C1	Analog red	Out	Not in use
C2	Analog green	Out	Not in use
C3	Analog blue	Out	Not in use
C4	Analog horizontal sync	Out	Not in use
C5	Analog ground	-	Not in use

*The signal direction is referred to HSMC card.

4.7 SD/SDIO/MMC reader

Memory Card Reader interface block diagram is shown on the next figure:

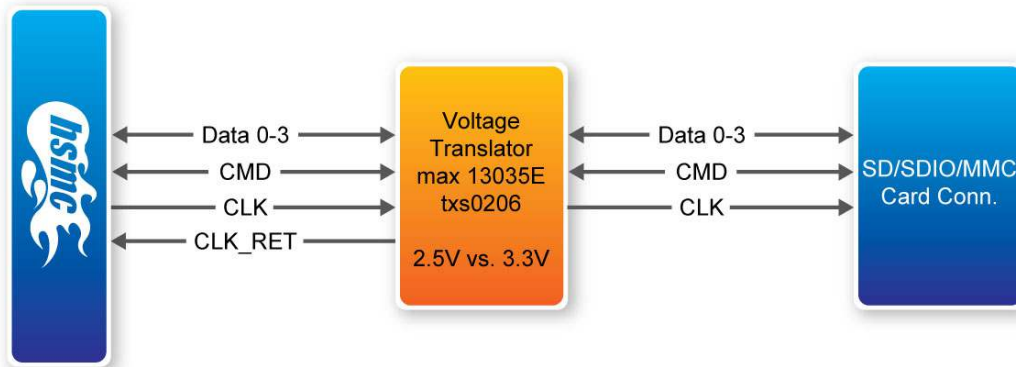

Figure 4-7 SD Card Reader Block Diagram

This interface should include bi-directional voltage translators in order to be compatible with SD/SDIO cards standard voltage levels. The Storage Cards will be plugged into on-board connector, which will support hot-plugging of the card.

The following table describes the SD Card pin-out:

Table 4-11 SD Card Reader Socket Pin-out

<i>Pin</i>	<i>Name</i>	<i>Direction</i>	<i>Description</i>
1	CD/DAT3	Bidir	Card Detect/Data line
2	CMD	Bidir	Command/Response
3	Vss1	Power	Ground
4	Vdd	Power	Supply Voltage
5	CLK	Input	Clock
6	Vss2	Power	Ground
7	DAT0	Bidir	Data line 0
8	DAT1	Bidir	Data line 1
9	DAT2	Bidir	Data line 2

In addition to card interface, the card socket contains two physical switches that used to detect card insertion/de-insertion and status on the write protect switch on the card. The status of these switches is routed to HSMC interface as well. SD Card bus time diagram is shown below:

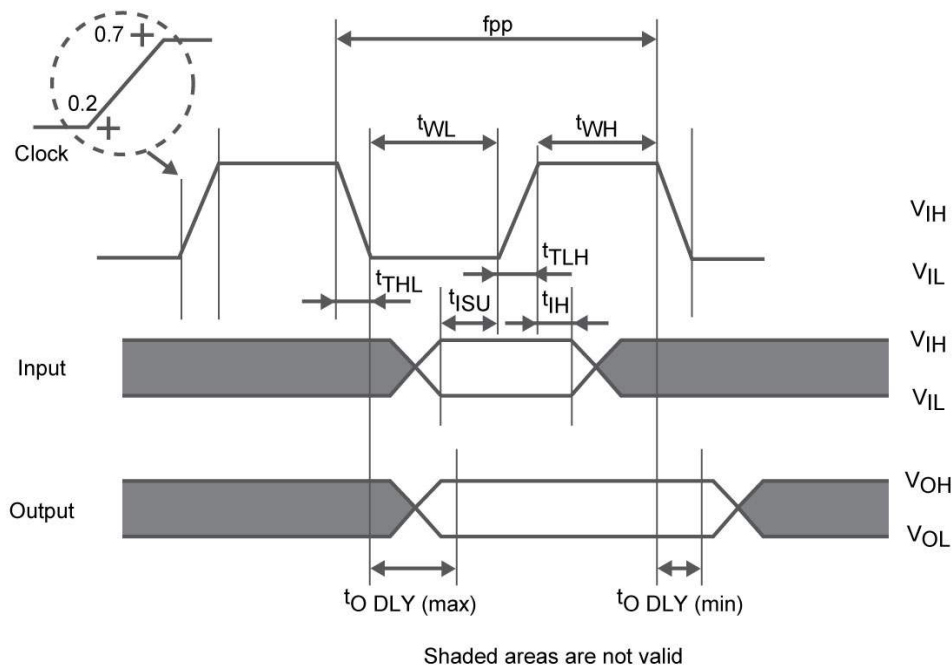

Figure 4-8 SD Card Signal Timing

4.8 EEPROM

The Microchip Technology Inc. 24AA08/24LC08B (24XX08*) is an 8 Kbit Electrically Erasable PROM. The device is organized as four blocks of 256 x 8-bit memory with a 2-wire serial interface. Low-voltage design permits operation down to 1.7V, with standby and active currents of only 1 μ A and 1 mA, respectively. The 24XX08 also has a page write capability for up to 16 bytes of data. The 24XX08 is available in the standard 8-pin PDIP, surface mount SOIC, TSSOP, 2x3 DFN, 2x3 TDFN and MSOP packages, and is also available in the 5-lead SOT-23 package.

4.9 Power

There are two power rails that are supplied through HSMC connector +12V and +3.3V. All the required on-board voltages are generated from these voltage rails. However due to possible excessive power requirements to support two hard drives, there is an option to supply the power from external power supply through power plug. On board DC/DC regulator will generate +12V and supply it to all the downstream power rails. This option is selected by on-board jumper.

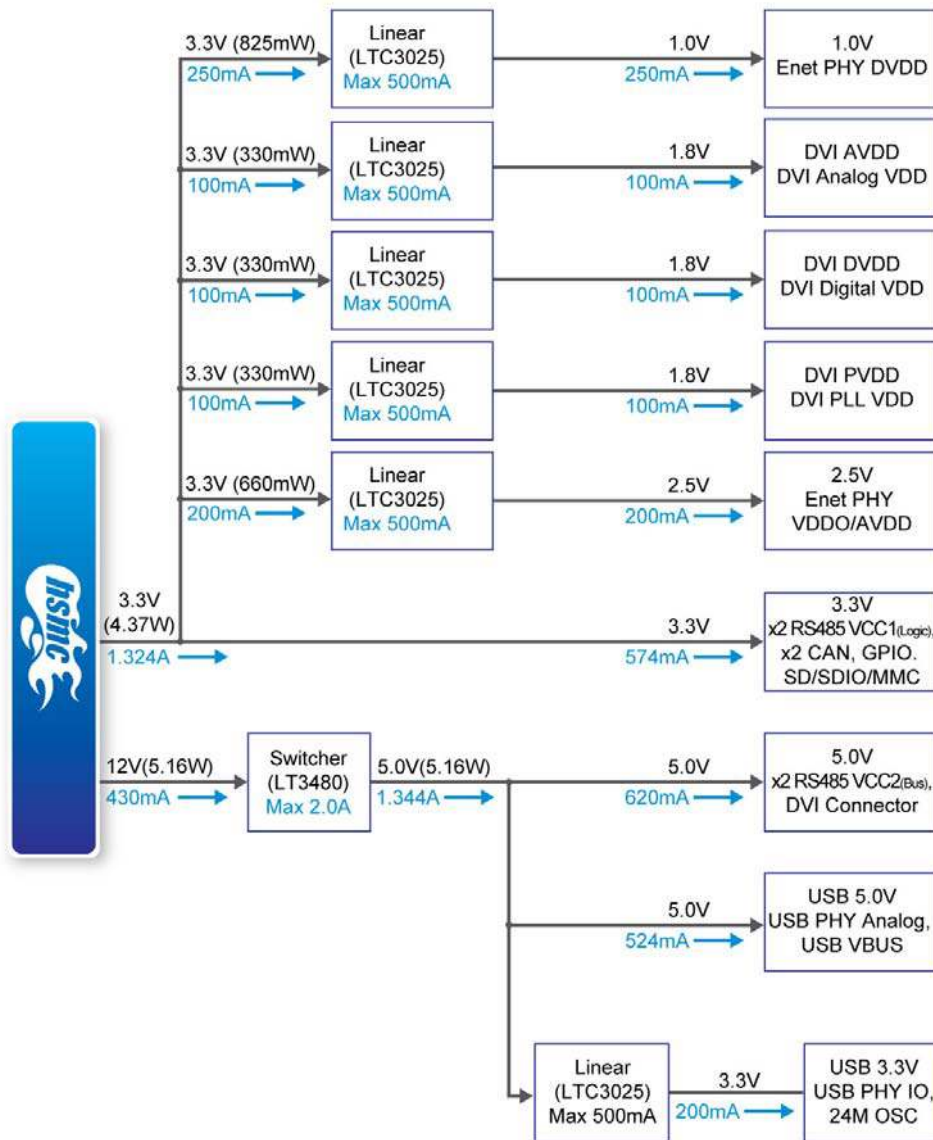

Figure 4-9 Power Tree

5.1 Revision History

<i>Version</i>	<i>Change Log</i>
V1.0	Initial Version (Preliminary)
V1.1	Modify Table 4-9

5.2 Copyright Statement

Copyright © 2011 Terasic Technologies. All rights reserved.