

300 W very high AC input voltage LED driver with digital power control



Features

- System architecture based on transition mode boost PFC, half bridge LCC and synchronous rectification (full bridge)
- 270-480 V_{AC} input voltage range
- Output can be configured in constant current (CC) or constant voltage (CV) mode:
 - 300 W maximum O/P power rating
 - CV mode: 48.5 V ± 1%
 - CC mode: 6.25 A ± 2.5% with voltage drop from 36 to 48 V
- Peak efficiency >93.5%
- Power Factor > 0.9 for load > 33% of max. load of the input voltage range
- THD < 20% for load > 25% of max. load of the input voltage range
- Dimming control in CC mode configuration:
 - 0-10 V control
 - 1% resolution
 - analog dimming
- Soft start
- Protections: I/P and O/P under and overvoltage protection, O/P open/no load circuit protection, O/P short/overload circuit protection
- Digitally controlled by [STM32F334R8](#)
- RoHS compliant
- WEEE compliant (2012/19/UE RAEE II)

Product summary	
300 W output digitally controlled HV AC Input HB LED driver	STEVAL-LLL009V1
Firmware for STEVAL-LLL009V1 based on STM32F334R8 MCU	STSW-LLL009FW
Mainstream mixed signal MCU ARM Cortex-M4 core with DSP and FPU	STM32F334R8
Galvanically isolated 4 A half-bridge dual channel gate driver	STGAP2D
N-channel 950 V, 0.275 Ohm typ., 17.5 A MDmesh DK5 Power MOSFET in TO-247 package	STW20N95DK5
N-channel 950 V, 0.275 Ohm typ., 17.5 A MDmesh K5 Power MOSFET	STW20N95K5
N-channel 100 V, 0.0068 Ohm typ., 80 A STripFET F7 Power MOSFET in TO-220 package	STP100N10F7
Applications	LED Lighting and Controls

Description

The [STEVAL-LLL009V1](#) digitally controlled 300 W power supply consists of power factor correction (PFC) and half-bridge LCC resonant converter power stages. An [STM32F334R8](#) microcontroller implements DC-DC and output synchronous rectification digital control, while the PFC is driven in transition mode by the [L6562AT](#) controller. The system supports constant voltage (CV) and constant current (CC) operation.

MDmesh K5 and MDmesh DK5 Power MOSFETs are used in the PFC and LCC half-bridge, respectively, to ensure maximum efficiency, while the STripFET F7 Power MOSFET is employed to reduce conduction losses in the synchronous rectification stage on the secondary side.

Both the primary and secondary sections are supplied by an off-line flyback circuit based on [VIPER267KDTR](#) high voltage converter for ultra-wide input which provides regulated voltages to the control board, the gate driver ICs and the signal conditioning circuits.

Formal testing and measurement results confirm the ability and performance of ST power products combined with comprehensive digital control to deliver high efficiency, power factor near unity, and low THD across wide input voltage and load conditions.

1 Block diagram

Figure 1. STEVAL-LLL009V1 functional block diagram

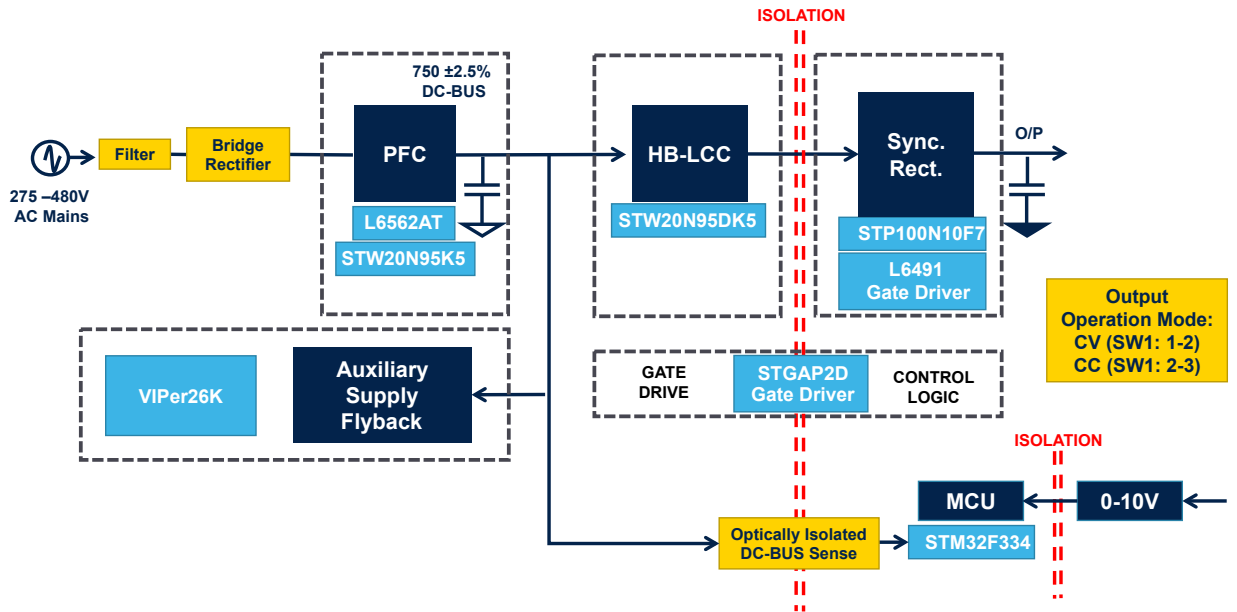

Figure 3. Power board - DC-DC converter

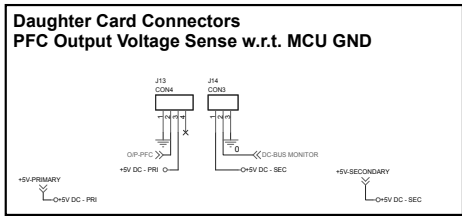
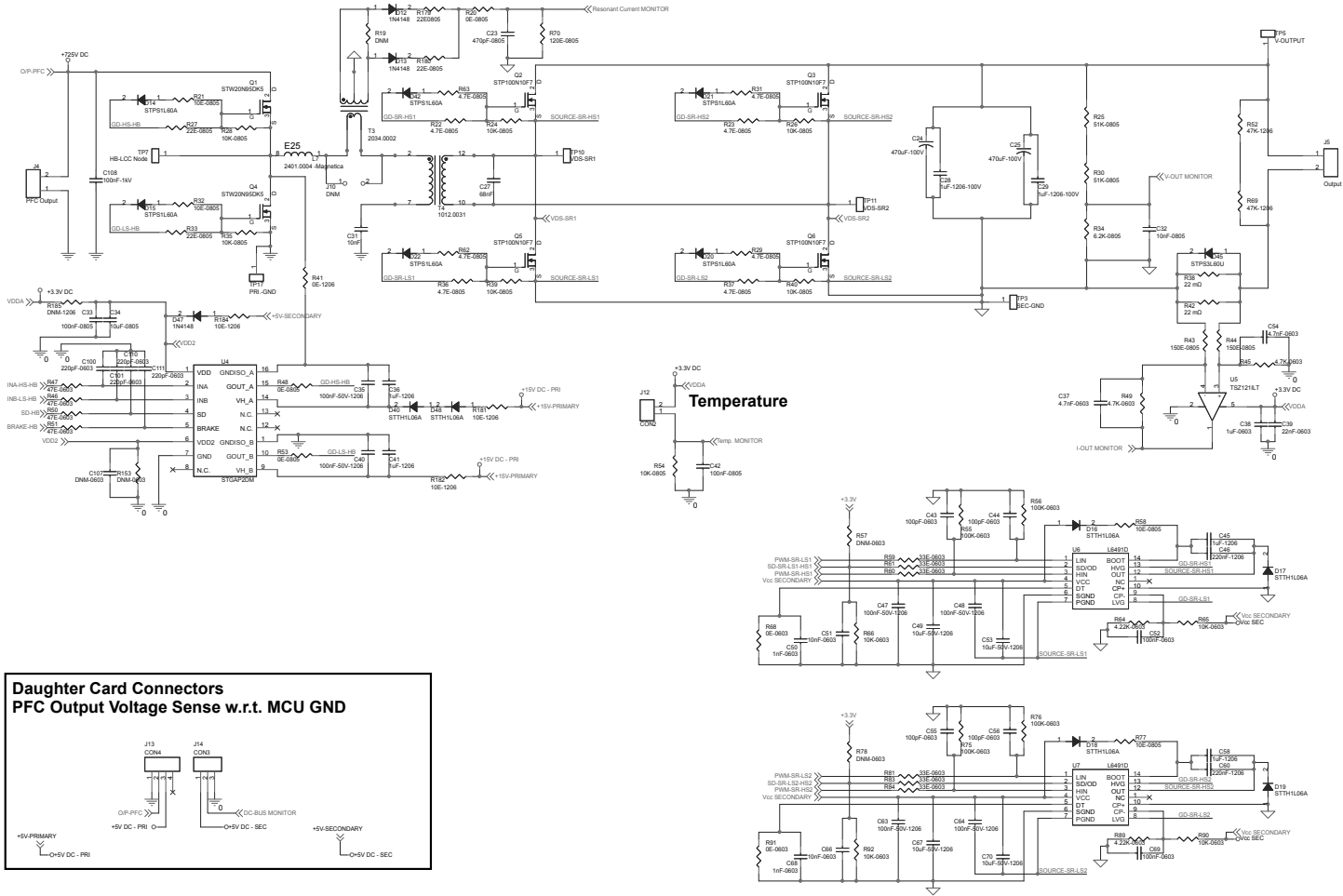

Figure 4. Power board - Aux power supply

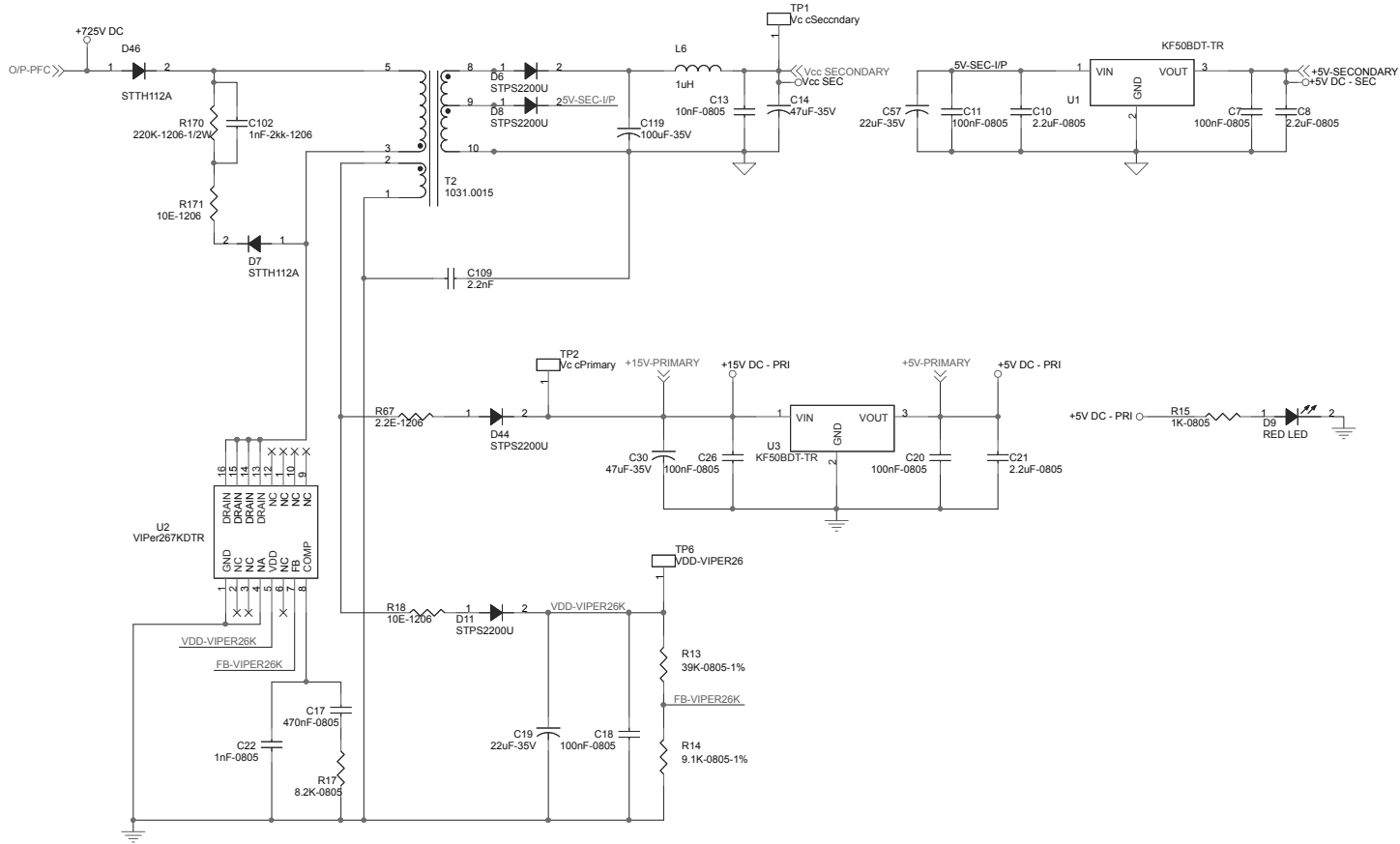
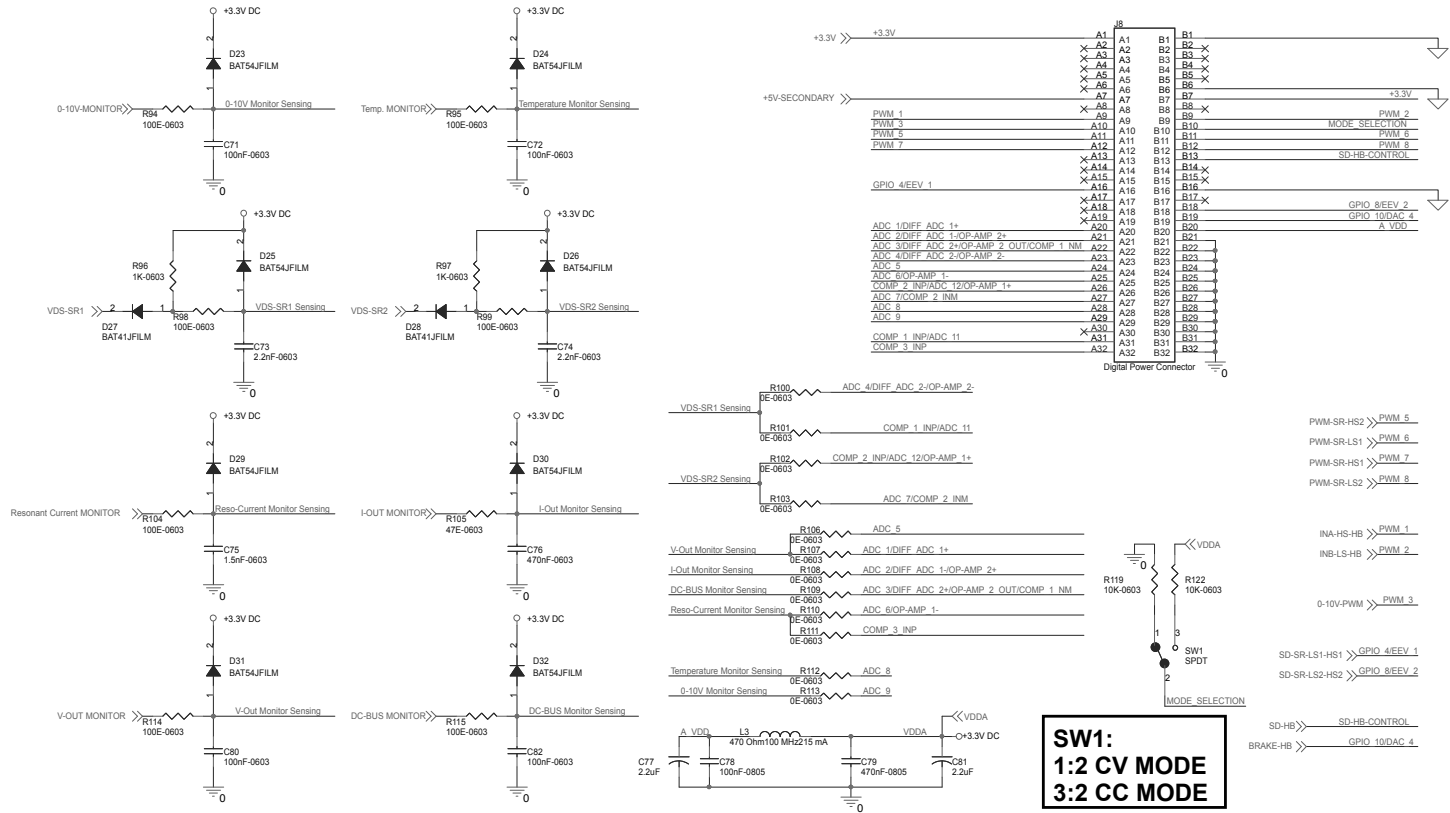

Figure 5. Power board - MCU connector



Note: The microcontroller ground is referenced to the power converter secondary side. The secondary side ground of the power converter and the ground denoted by 0 are combined on the microcontroller daughter card. The analog and control signals ground are denoted by 0 to get star ground connection and reduce switching noise interference.



Figure 6. Daughter board - PFC voltage read with isolation

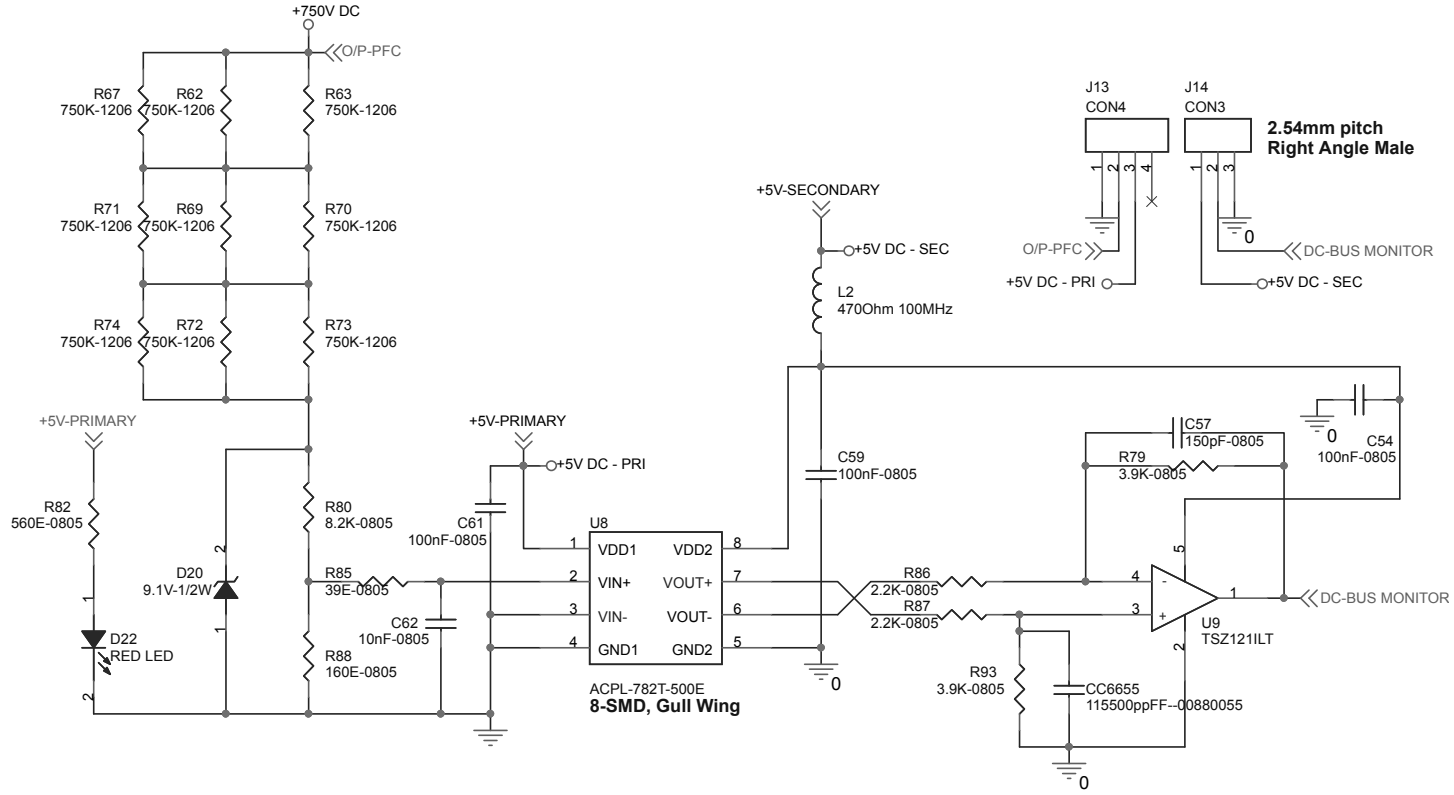
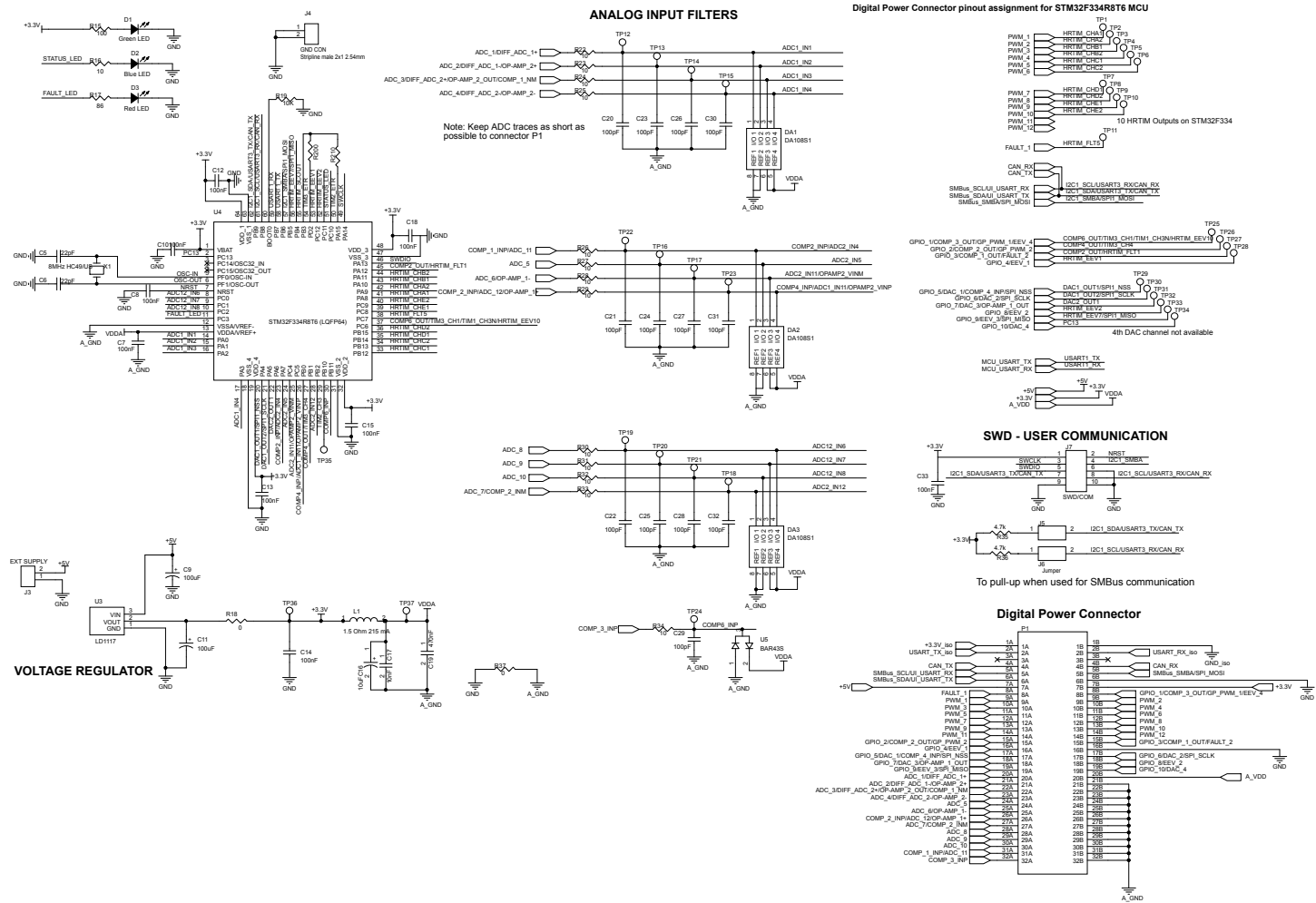

Figure 7. Control board - MCU and connector schematic



Note: The microcontroller ground is referenced to the power converter secondary side. On the microcontroller schematic, the ground symbol is denoted by GND and A_GND (Analog Signal Ground). Different symbols have been used for better PCB layout. Both GND and A_GND are combined on the microcontroller at R37.



Figure 8. Control board - opto-isolated communication

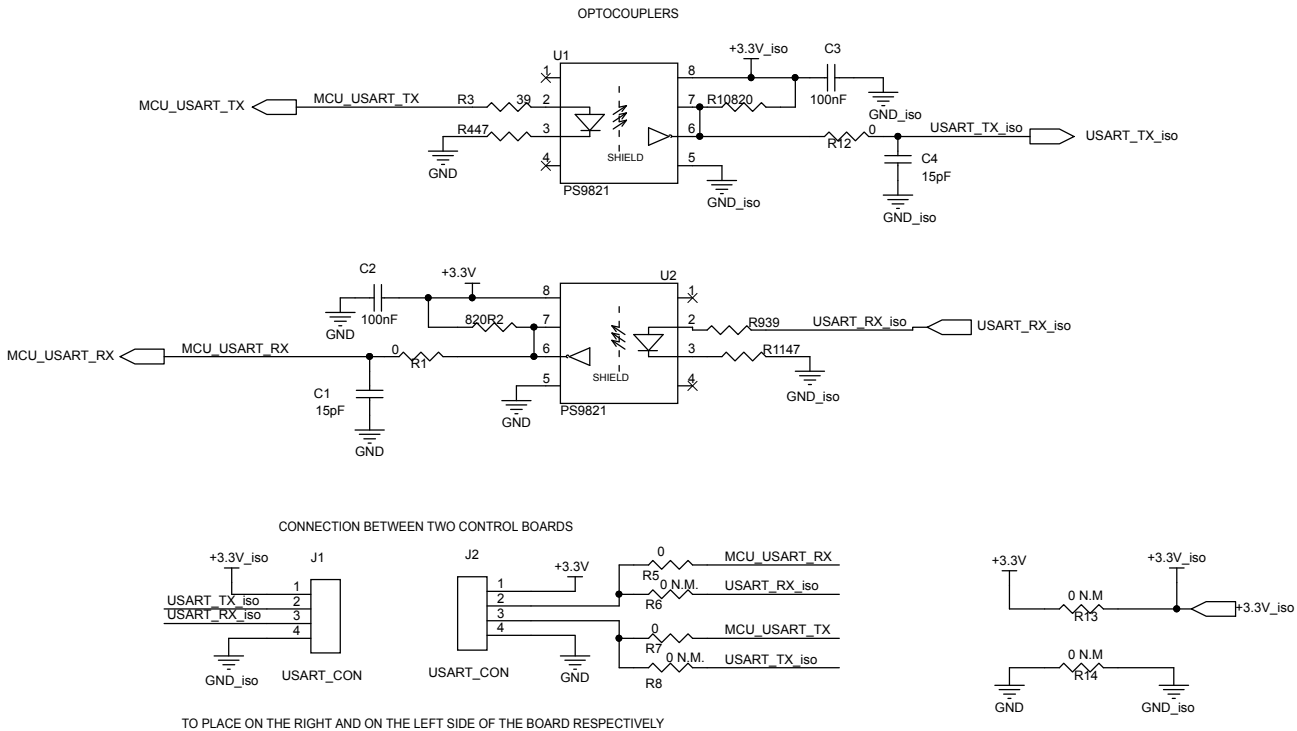
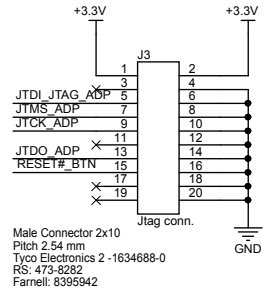
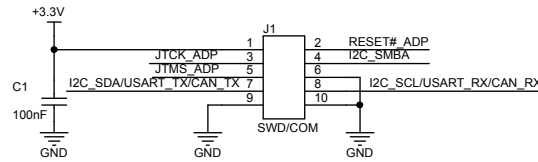

Figure 9. Adapter board

JTAG



SWD - USER COMMUNICATION



USER COMMUNICATION CONFIG

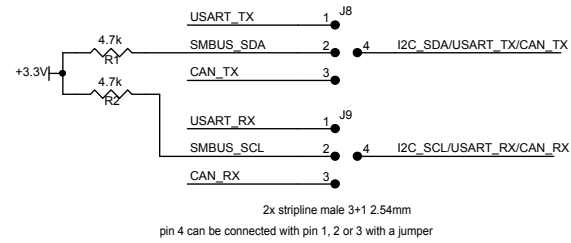

CAN

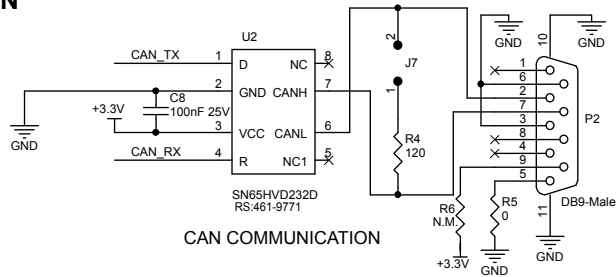

SMBUS

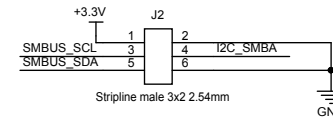

RESET BUTTON

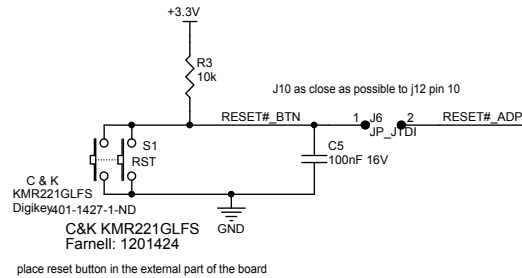

RS-232

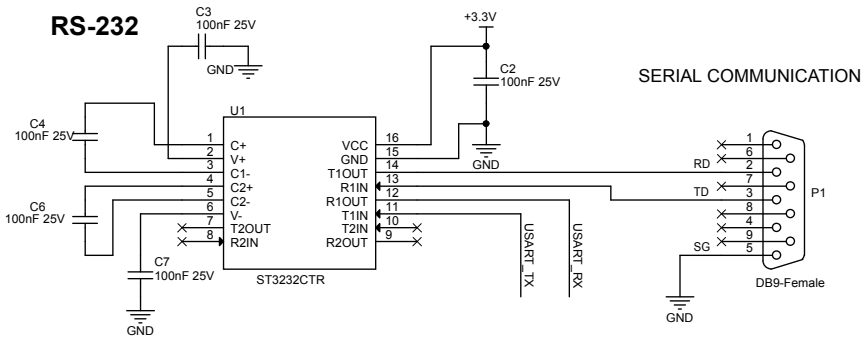

Revision history

Table 1. Document revision history

Date	Version	Changes
17-Nov-2020	1	Initial release.

IMPORTANT NOTICE – PLEASE READ CAREFULLY

STMicroelectronics NV and its subsidiaries (“ST”) reserve the right to make changes, corrections, enhancements, modifications, and improvements to ST products and/or to this document at any time without notice. Purchasers should obtain the latest relevant information on ST products before placing orders. ST products are sold pursuant to ST’s terms and conditions of sale in place at the time of order acknowledgement.

Purchasers are solely responsible for the choice, selection, and use of ST products and ST assumes no liability for application assistance or the design of Purchasers’ products.

No license, express or implied, to any intellectual property right is granted by ST herein.

Resale of ST products with provisions different from the information set forth herein shall void any warranty granted by ST for such product.

ST and the ST logo are trademarks of ST. For additional information about ST trademarks, please refer to www.st.com/trademarks. All other product or service names are the property of their respective owners.

Information in this document supersedes and replaces information previously supplied in any prior versions of this document.

© 2020 STMicroelectronics – All rights reserved