



ICD-SERIES // HIGH PRECISION MEASUREMENT

Index

1.	Introduction.....	2
2.	Application.....	2
3.	Additional features.....	2
4.	Block Diagram.....	3
4.1.	Ranges.....	3
4.2.	Communication interface.....	3
4.3.	System integration.....	4
5.	Technical Data.....	5
5.1.	Maximum ratings.....	5
5.2.	Operation conditions.....	5
5.3.	Current measurement.....	5
5.4.	Supply voltage measurement.....	6
5.5.	Temperature measurement (on-chip).....	6
5.6.	Communication.....	6
5.7.	Connector (only suggestion).....	6
5.8.	Mechanical dimension.....	7
5.9.	Bus bar connection.....	7
5.10.	Pin configuration.....	8
5.11.	Part description.....	9
6.	CAN-Protocol.....	10
6.1.	Message types and layout.....	10
6.2.	Request - message.....	11
6.3.	Multiplexed Request-messages (measurement).....	11
6.4.	Multiplexed Request-messages (configuration).....	11
6.5.	Multiplexed Request-messages (control).....	14
6.6.	Multiplexed Request-messages (information).....	14
6.7.	Response - Message.....	16
6.8.	Multiplexed Response – messages (measurement).....	16
6.9.	Multiplexed Response – messages (configuration).....	17
6.10.	Multiplexed Response – messages (control).....	18
6.11.	Multiplexed Response – messages (information).....	19
6.12.	Result – message.....	22
6.13.	Access-Mode / Storing and reset.....	23
6.14.	Default values.....	24
6.15.	Startup Messages.....	24
7.	Qualification.....	25
7.1.	MBN LV 124-2, 2009-11 / DIN 40 050-9.....	25
7.2.	ISO 16750-2:2003.....	26
7.3.	ISO 7637-2:2004 (ICD-A).....	26
7.4.	ISO 10605:2008 (ICD-A).....	26
7.5.	ISO 11452-2 (ICD-A).....	26
7.6.	EN 55025 (ICD-A).....	26
7.7.	IEC/EN 61000-4-2 (ICD-C).....	26
7.8.	IEC/EN 61000-6-2 (ICD-C).....	27
7.9.	EN 55011 (ICD-C).....	27

1. Introduction

The ICD series is a highly compact precision current measurement system. The system uses shunt-based current measurement technology for maximum accuracy. It consists of a 16Bit ADC for measurement acquisition and a microcontroller for processing and communication purposes. The current measurement value is available within a 24Bit range. An internal sampling rate of 1 kHz is used and a moving averaging filter can be programmed.

The communication is based on CANbus 2.0a/b with a data rate up to 1Mbit/s. A CANbus data base container (DBC) is available to support fast system integration.

The ICD series is covered with a molded housing to resist a wide range of environmental influences. With the highly compact design it can easily be integrated where installation space is limited.

2. Applications

The ICD series is designed for a wide range of DC applications.

For example:

- UPS systems
- Energy storage systems
- Battery applications
- automotive and industrial application

3. Additional features

Sleep mode:

During the sleep mode the own current consumption is very low. The current measurement and the ampere-hour meter runs in the background. It's possible to realize the wake up over different functions (timer, rest, current threshold...)

The ICD can measure its own current consumption.

4. Block Diagram

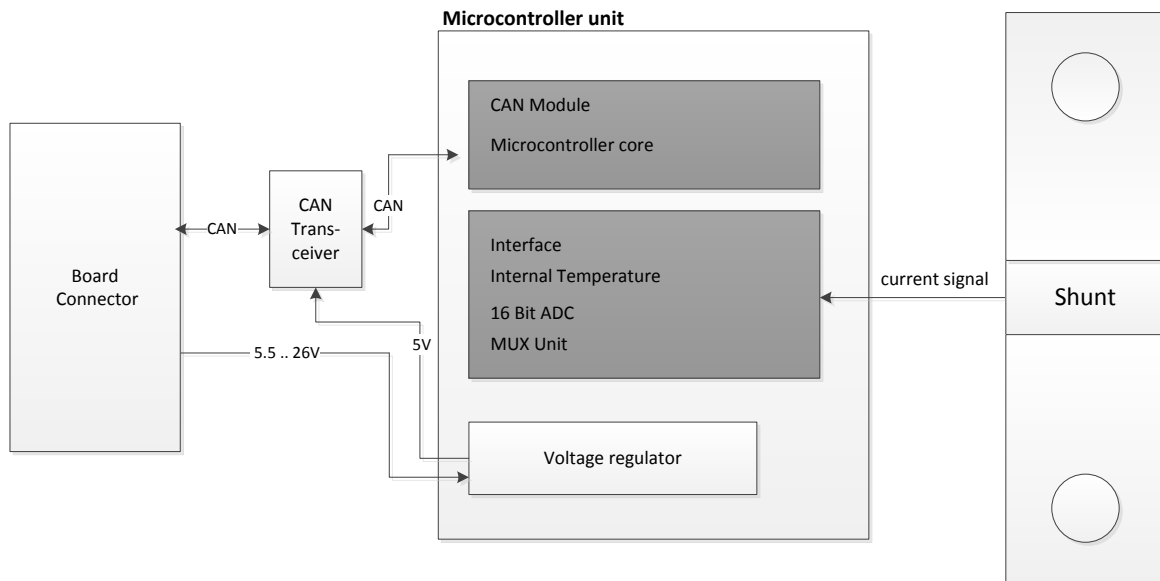

4.1. Ranges

The ICD product family offers three different, customers selectable current measurement ranges. The selection of a required measurement range determines the shunt resistance.

Every shunt value has unique characteristics (see chapter “technical data”). One limitation characteristic is the maximum load of the shunt resistor. The limitation is based on the internal thermal resistance and a maximum tolerable heating of 20 Kelvin.

Note:

To ensure that the measurement limits are in the specified range, care has to be taken to the thermal connection between shunt and busbar. In case of an inadequate shunt to busbar connection the sensor can possibly overheat due to the internal power dissipation.

4.2. Communication interface

The ICD series use the standard CAN 2.0 a/b protocol.

CANbus termination: The standard configuration is without 120 Ω CANbus termination on board. It is possible to order the sensor with internal CANbus termination.

4.3. System integration

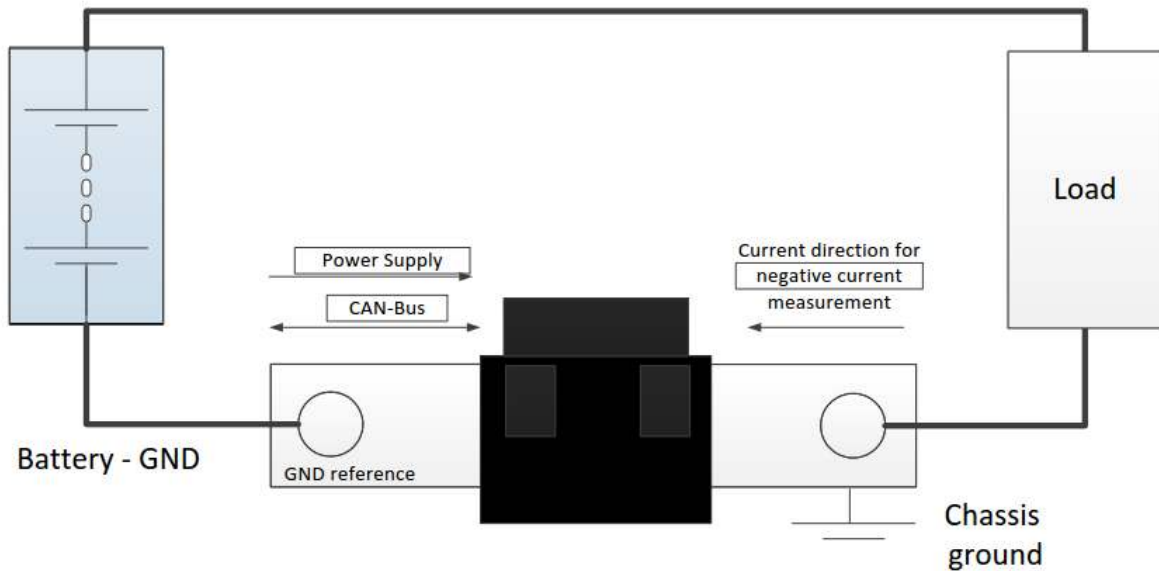

Important note:

Don't connect PIN 3 (V_{SS}) with the Battery GND. It's usable as reference point for laboratory application. Otherwise with a bad connection between Battery and Shunt GND the current would flow through PIN 3, which can damage the sensor!

5. Technical Data

5.1. Maximum ratings

Parameter	Min		max	Unit
Storage temperature	-40	-	+125	°C
Supply voltage	-36	-	+38	V

Parameter	100	300	500	
Extended load (max. time)				
5min	±120	±320	±730	A
30s	±200	±430	±860	A
10s	±300	±600	±1000	A
1s	±900	±1600	±2700	A
200ms	±2000	±3600	±6000	A

5.2. Operation conditions

Parameter	min.	typ.	Max.	Unit
Operating temperature	-40		+105	°C
Storage temperature	-40		+125	°C
Supply voltage	5.5	12	26	V
Current consumption	< 15	< 30	< 50	mA
Current consumption In sleep mode		< 100	< 250	µA
Re-/ Startup time		250		ms
Waiting time power on/off	2			ms

5.3. Current measurement

Parameter				Unit
Nominal measurement range (depending on shunt)	±100	±300	±500	A
Power loss	< 3	< 9	< 9	W
Overcurrent measurement range	±500	±1500	±2500	A
Initial accuracy		±0.1		% of rdg ¹
Total accuracy (-25°C ... 85°C)		±0.5		% of rdg ¹
Total accuracy (-40°C ... 105°C)		±0.8		% of rdg ¹
Offset	< ±10	< ±35	< ±60	mA
Noise ²	< ±8	< ±20	< ±35	mA (RMS)
Linearity ³		0.1		% of range
Resolution		1		mA

¹ Failure of reading

² Without averaging

³ In nominal measurement range

5.4. Supply voltage measurement

Parameter	Min	Max	Unit
Measurement range	+5.5	+26	V
Initial accuracy		±0.1	% of rdg
Total accuracy		±0.8	% of rdg
Offset		±35	mV
Noise		±60	mV (rms)
Resolution		0.5	mV

5.5. Temperature measurement (on-chip)

Parameter	Min	Max	Unit
Measurement range	-40	+125	°C
Initial accuracy		± 3	°C
Total accuracy		± 5	°C
Resolution		0.1	°C

5.6. Communication

Interface	Specification	Speed	Max. number of Unit
CANbus	2.0 a/b	250kbit/s; 500kbits/s; 1Mbit/s	6

Direction		MIN	MAX	UNIT	
V _{CC}	Supply voltage for CAN	4.75	5.25	V	
V _I or V _{IC}	Voltage at any bus terminal (separately or common mode)	-12	12	V	
V _{max}	Voltage at any bus terminal (max. rating)	-26	26	V	
V _{IH}	High-level input voltage	TXD,S	2	5.25	V
V _{IL}	Low-level input voltage	TXD,S	0	0.8	V
V _{ID}	Differential input voltage		-6	6	V
I _{OH}	High-level output current	Driver	-70		mA
		Receiver	2		mA
I _{OL}	Low-level output current	Driver	70		mA
		Receiver	2		mA

5.7. Connector (only suggestion)

For ICD - A

	Manufacturer	Type	No. of Pins	Color	Man. Part no.
Wire connector	TE connectivity		6	Black	1-1718646-1
Crimp contact					1452671-1
Sealing					967067-1

For ICD - C

	Manufacturer	Type	No. of Pins	Color	Man. Part no.
Wire connector	PHOENIX CONTACT		6	green	1893724

5.8. Mechanical dimension

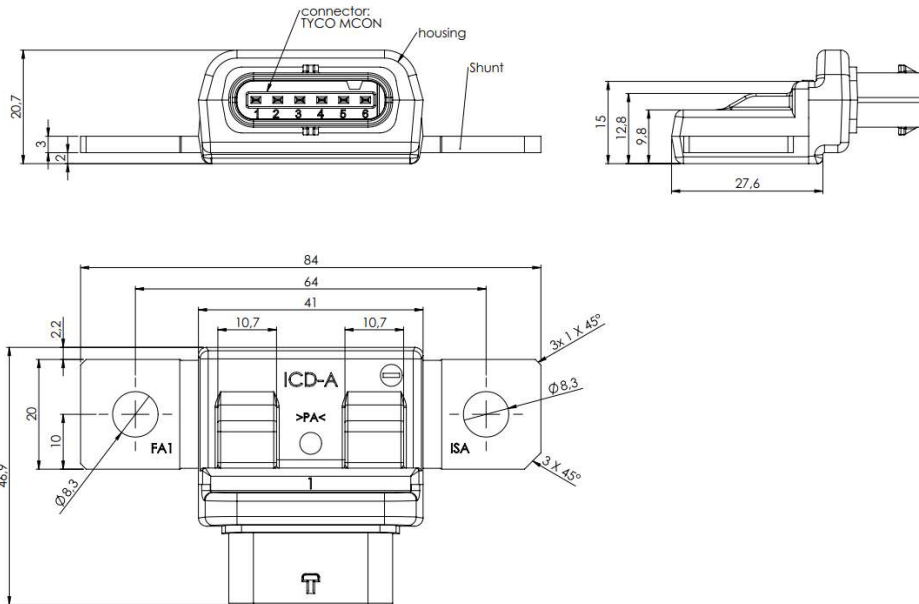

Product: ICD-A

Note: These drawings show only the basic dimensions. Detailed dimensions and tolerances can be requested.

5.9. Bus bar connection

The accuracy and repeatability of current measurement depends from the quality of the connection between customer's bus bar and the shunt bus bar

To ensure a good and useful connection between customer's bus bar and the shunt consider the following instructions:

- Mounting the sensor on a bus bar is highly recommended (instead of mounting a cable onto the shunt)
- Screwing the sensor on a bus bar by using all mounting holes, never use less than the available hole for screwing
- Always use screws with an outer diameter of 8 mm (M8), using smaller screws (e. g. M6 or M5) is NOT recommended
- Never use flat washers between the bus bar and the shunt!
- All screws using for mounting must be tightened with a torque as equal as possible!
- The recommended torque is **15 – 20 Nm**
- Shunt and bus bar must be clean and free of grease

5.10. Pin configuration



Figure 1 Pin configuration

Connector	PIN	Description	Remark (module or basic)
1	CAN-L	CAN LOW	
2	CAN-H	CAN HIGH	
3	V _{ss}	(connected to Shunt GND, not needed if Shunt is connected to battery GND)	Only for laboratory application!
4	V _{cc}	(Ref. to Shunt GND)	
5	n/a	Do not connect pin e or pin f to any signal source!	
6	n/a	Do not connect pin e or pin f to any signal source!	

5.11. Part description

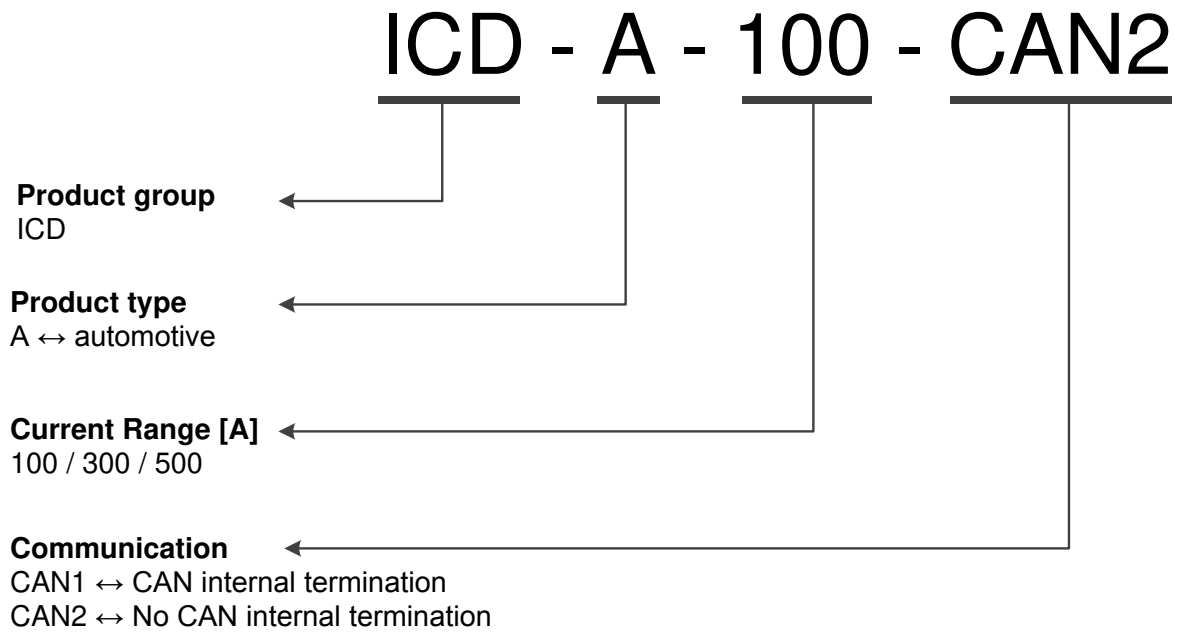

6. CAN-Protocol

2.0 a Format (11-bit-Identifier)

Start	Identifier	RTR	IDE	r0	DLC	DATA	CRC	ACK	EOF+IFS
1 Bit	11 Bit	1 Bit	1 Bit	1 Bit	4 Bit	0...8 Byte	16 Bit	2 Bit	10 Bit

2.0 b Format (29-bit-Identifier)

Start	Identifier	SRR	IDE	Identifier	RTR	r1	r0	DLC	DATA	CRC	ACK	EOF+IFS
1 Bit	11 Bit	1 Bit	1 Bit	18 Bit	1 Bit	1 Bit	1 Bit	4 Bit	0...8 Byte	16 Bit	2 Bit	10 Bit

Selectable bitrate

- 1.000.000 bit/s
- 500.000 bit/s
- 250.000 bit/s

Default parameters:

CAN bitrate = 500.000 bit/s

6.1. Message types and layout

Description	CAN-ID Default	DLC	Time	Remark
request	0x0500	8	Triggered	Function commands, SET and GET commands. A command-ID.byte is included for identification
response	0x0501	8	Triggered	Response to SET- and GET- commands from the <i>Request-message</i>
result	0x0502	8	Cyclic 1 ms (continuous mode)	Contains the results of <i>I</i> , <i>Ubatt</i> and <i>Status</i>

Table 1: Message types and layout

6.2. Request - message

The communication of the sensor is based on two CAN-frames. For getting and setting any information from/to the sensor the *cmd* (command)-Message with the ID 0x500 is required. Table 2 pictures the details of the cmd-message structure with its signals.

CAN msg cmd	D0	D1	D2	D3	D4	D5	D6	D7
0x500	MUX ID	P0...P6						

Table 2: CAN frame

Databyte 0 (D0) is a *multiplexor-signal* which controls the type of information for get-/set frames. It's named *Multiplex ID* (MUX ID).

6.3. Multiplexed Request-messages (measurement)

If not otherwise mentioned blank filed are don't care.

Message	MUX ID	P0	P1	P2	P3	P4	P5	P6
Trigger Result	0x00							
Get Result Temperature	0x01							
Get Result Ah Counter	0x02							

Table 3: MUX request messages

6.4. Multiplexed Request-messages (configuration)

Message	MUX ID	P0	P1	P2	P3	P4	P5	P6
Set Operation Mode	0x10	<Mode> 0x00 stop 0x01 continuous (def) 0x02 triggered	<output rate continuous mode [ms]> Ignored in mode 0x00, 0x02 unsigned 16 bit	<Option as bitfield> (0x00 – 0xff) 0b0000 0001 – invert current direction (*-1)				

Table 4: Set operation mode

Message	MUX ID	P0	P1	P2	P3	P4	P5	P6
Get Device ID	0x60							

Table 5: Get operation mode

Message	MUX ID	P0	P1	P2	P3	P4	P5	P6
Set Access Mode (for User access)	0x11	0x00 (def) no configuration possible						
		0x01 configuration mode for customer	0x30(0)	0x30(0)	0x30(0)	0x30(0)	0x30(0)	0x30(0)

Table 6: Set access mode

Message	MUX ID	P0	P1	P2	P3	P4	P5	P6
Get Access Mode (of User access)	0x61							

Table 7: Get access mode

Message	MUX ID	P0	P1	P2	P3	P4	P5	P6
Set Averaging	0x20	<Dept of averaging> 0x00 – 0xff						

Table 8: Set Averaging

Set number of averaged values, within measurement result. Averaged filter implemented to response floating averaged value.

Message	MUX ID	P0	P1	P2	P3	P4	P5	P6
Get Averaging	0x70							

Table 9: Get Averaging

Message	MUX ID	P0	P1	P2	P3	P4	P5	P6
Set OC limit	0x21	<activation limit positive [A]> unsigned 24 bit			<activation limit negative [A]> unsigned 24 bit			

Table 10: Set OC limit

Set OC signal within status of result message.

Message	MUX ID	P0	P1	P2	P3	P4	P5	P6
Get OC limit	0x71							

Table 11: Get OC limit

Message	MUX ID	P0	P1	P2	P3	P4	P5	P6
Set CAN configuration	0x22	<Baudrate> 0x00 – 250kBaud 0x01 – 500kBaud (def) 0x02 – 1MBaud	<CAN Mode> 0x00 – 2.0 a 0x01 – 2.0 b					

Table 12: Set CAN configuration

New configuration valid after restart

Message	MUX ID	P0	P1	P2	P3	P4	P5	P6
Get CAN configuration	0x72							

Table 13: Get CAN configuration

Message	MUX ID	P0	P1	P2	P3	P4	P5	P6
Set CAN ID request	0x23	<S/N HL byte>	<S/N LH byte>	<S/N LL byte>	<ID HH byte>	<ID HL byte>	<ID LH byte>	<ID LL byte>

Table 14: Set CAN ID request

Parameters including lower 3 bytes of serial number, 4 bytes new CAN-ID

Message	MUX ID	P0	P1	P2	P3	P4	P5	P6
Get CAN ID request	0x73							

Table 15: Get CAN ID request

Message	MUX ID	P0	P1	P2	P3	P4	P5	P6
Set CAN ID response	0x24	<S/N HL byte>	<S/N LH byte>	<S/N LL byte>	<ID HH byte>	<ID HL byte>	<ID LH byte>	<ID LL byte>

Table 16: Set CAN ID response

Parameters including lower 3 bytes of serial number, 4 bytes new CAN-ID

Message	MUX ID	P0	P1	P2	P3	P4	P5	P6
Get CAN ID response	0x74							

Table 17: Get CAN ID response

Message	MUX ID	P0	P1	P2	P3	P4	P5	P6
Set CAN ID result	0x25	<S/N HL byte>	<S/N LH byte>	<S/N LL byte>	<ID HH byte>	<ID HL byte>	<ID LH byte>	<ID LL byte>

Table 18: Set CAN ID result

Parameters including lower 3 bytes of serial number, 4 bytes new CAN-ID

Message	MUX ID	P0	P1	P2	P3	P4	P5	P6
Get CAN ID result	0x75							

Table 19: Get CAN ID result

Message	MUX ID	P0	P1	P2	P3	P4	P5	P6
Set user p/w	0x26	<new P/W> 0x20 – 0x7e	<new P/W> 0x20 – 0x7e	<new P/W> 0x20 – 0x7e	<new P/W> 0x20 – 0x7e	<new P/W> 0x20 – 0x7e	<new P/W> 0x20 – 0x7e	

Table 20: Set user P/W

Set password only in related user mode

Message	MUX ID	P0	P1	P2	P3	P4	P5	P6
Get user p/w	0x76							

Table 21: Get user P/W

Set password only in related user mode

6.5. Multiplexed Request-messages (control)

Message	MUX ID	P0	P1	P2	P3	P4	P5	P6
Reset	0x40	<Reset option > 0x01 – Reset all parameters to default 0x02 – Force hard reset						

Table 22: Reset

Message	MUX ID	P0	P1	P2	P3	P4	P5	P6
Goto sleep	0x41	<Wakeup source as bitfield> 0b0000 0001 – timer 0b0000 0010 – I-threshold 0b0000 0100 – Ah - threshold	<Timer value[1 s]> Unsigned 16 bit 0 s – 65000 s		<I – threshold [1 mA]> Unsigned 16 bit 0 mA to 250 mA		<Ah – threshold [1 mAs]> Unsigned 16 bit 0 mAs to 65000 mAs	

Table 23: Goto sleep

Message	MUX ID	P0	P1	P2	P3	P4	P5	P6
Clear Ah counter	0x42							

Table 24: Clear Ah counter

Message	MUX ID	P0	P1	P2	P3	P4	P5	P6
Clear Status Bits	0x43							

Table 25: Clear Status Bits

Message	MUX ID	P0	P1	P2	P3	P4	P5	P6
Store settings	0x44							

Table 26: Store Settings

Storing of trigger mode, CAN configuration, averaging setting, CAN ID request, CAN ID response, CAN ID result and Result structure,

Message	MUX ID	P0	P1	P2	P3	P4	P5	P6
Clear event counter	0x45							

Table 27: Clear event counter

6.6. Multiplexed Request-messages (information)

Message	MUX ID	P0	P1	P2	P3	P4	P5	P6
Get device ID	0x50							

Table 28: Get device ID

Message	MUX ID	P0	P1	P2	P3	P4	P5	P6
Get SFW Version	0x51							

Table 29: Get FW version

Message	MUX ID	P0	P1	P2	P3	P4	P5	P6
Get Serial no.	0x52							

Table 30: Get serial no.

Message	MUX ID	P0	P1	P2	P3	P4	P5	P6
Get HW Version	0x53							

Table 31: Get HW version

Message	MUX ID	P0	P1	P2	P3	P4	P5	P6
Get article no	0x54							

Table 32: Get article no.

Message	MUX ID	P0	P1	P2	P3	P4	P5	P6
Get revision	0x55							

Table 33: Get revision

Message	MUX ID	P0	P1	P2	P3	P4	P5	P6
Get up time	0x56							

Table 34: Get up time

Message	MUX ID	P0	P1	P2	P3	P4	P5	P6
Get lifetime counter	0x57							

Table 35: Get lifetime counter

Message	MUX ID	P0	P1	P2	P3	P4	P5	P6
Get status bits	0x58							

Table 36: Get status bits

Requests bitmask of measurement status and system status

Message	MUX ID	P0	P1	P2	P3	P4	P5	P6
Get CRC code	0x59							

Table 37: Get CRC Code

Message	MUX ID	P0	P1	P2	P3	P4	P5	P6
Get Event Counters	0x5b	<Measurement status> 0x01 – 0xff error counter 0x01 – adc interrupt 0x02 – overflow adc ch1 0x03 – overflow adc ch 2 0x04 – overflow adc ch 3 0x05 – open circuit I 0x06 – open circuit U 0x07 – open circuit Tchip 0x08 – open circuit Text 0x09 – calibration data 0x0a – OCS ative	<System Status> 0x01 – 0xff Error Counter 0x01 – code crc 0x02 – calibration data crc 0x03 – CAN Rx 0x04 – CAN Tx 0x05 – overtemp 0x06 – undertemp 0x07 – power failure 0x08 – system clock 0x09 – system init 0x0a – configuration 0x0b – eeprom r/w 0x10 – power on reset 0x20 – low voltage reset 0x30 – ext. pin reset 0x40 – clock mon. reset 0x50 – COP ED reset					

Table 38: Get event counters

Request counters of measurement status and system status

6.7. Response - Message

Response to the get/set request messages are given in the response message. Layout and byte order correspond to the structure from response *message*, shown in the table below.

CAN msg msg	ID	D0	D1	D2	D3	D4	D5	D6	D7
Message	0x501	Response MUX ID	P0	P1	P2	P3	P4	P5	P6

Table 39: Response message – CAN frame

6.8. Multiplexed Response – messages (measurement)

Message	Response to Message	Response MUX ID	P0	P1	P2	P3	P4	P5	P6
Temperature	Get result temperature	0x91	<T_{chip}> 1/10 °C signed 16 bit		<T_{ext}> 1/10 °C signed 16 bit		0x00	0x00	0x00

Table 40: Temperature

Message	Response to Message	Response MUX ID	P0	P1	P2	P3	P4	P5	P6		
Ah Counter	Get Result Ah Counter	0x92	<Ah counter [mAs]> signed 32 bit						0x00	0x00	0x00
	Clear Ah counter										

Table 41: Ah counter

6.9. Multiplexed Response – messages (configuration)

Message	Response to Message	Response MUX ID	P0	P1	P2	P3	P4	P5	P6
Operation mode	Set Operation Mode Get Operation Mode	0xA0	<Mode> 0x00 – stop 0x01- continuous 0x02 – triggered	<Output rate [ms]> Mode 0x00 → 0x00 Mode 0x01 → 0x01 – 0xff Mode 0x02 → 0x01 unsigned 16 bit		<Option as field> 0x00 – 0xff 0b0000 0001 – invert current direction (*-1)	0x00	0x00	0x00

Table 42: Operation mode

Message	Response to Message	Response MUX ID	P0	P1	P2	P3	P4	P5	P6
Access mode	Set Access Mode Get Access Mode	0xA1	<Access mode> 0x00 – no cfg possible 0x01 - cfg possible	0x00	0x00	0x00	0x00	0x00	0x00

Table 43: Access mode

Message	Response to Message	Response MUX ID	P0	P1	P2	P3	P4	P5	P6
Averaging	Set Averaging Get Averaging	0xB0	<Depth of averaging> 0x00 – 0xff	0x00	0x00	0x00	0x00	0x00	0x00

Table 44: Averaging

Message	Response to Message	Response MUX ID	P0	P1	P2	P3	P4	P5	P6
OC limit	Set OC Limit Get OC Limit	0xB1	<Activation limit positive [A]> unsigned 24 bit			<Activation limit negative [A]> unsigned 24 bit			0x00

Table 45: OC limit

Message	Response to Message	Response MUX ID	P0	P1	P2	P3	P4	P5	P6
CAN configuration	Set CAN Configuration Get CAN Configuration	0xB2	<Baudrate> 0x00 – 250kBaud 0x01 – 500kBaud 0x02 – 1MBaud	<CAN Mode> 0x00 – 2.0 a 0x01 – 2.0 b		0x00	0x00	0x00	0x00

Table 46: CAN configuration

Message	Response to Message	Response MUX ID	P0	P1	P2	P3	P4	P5	P6
CAN ID request	Set CAN ID Request Get CAN ID Request	0xB3	<S/N HL byte>	<S/N LH byte>	<S/N LL byte>	<ID HH byte>	<ID HL byte>	<ID LH byte>	<ID LL byte>

Table 47: CAN ID request

Includes lower 3 bytes of Serial number, 4 bytes data

Message	Response to Message	Response MUX ID	P0	P1	P2	P3	P4	P5	P6
CAN ID response	Set CAN ID Response Get CAN ID Response	0xB4	<S/N HL byte>	<S/N LH byte>	<S/N LL byte>	<ID HH byte>	<ID HL byte>	<ID LH byte>	<ID LL byte>

Table 48: CAN ID response

Includes lower 3 bytes of Serial number, 4 bytes data

Message	Response to Message	Response MUX ID	P0	P1	P2	P3	P4	P5	P6
CAN ID result	Set CAN ID Result Get CAN ID Result	0xB5	<S/N HL byte>	<S/N LH byte>	<S/N LL byte>	<ID HH byte>	<ID HL byte>	<ID LH byte>	<ID LL byte>

Table 49: CAN ID result

Includes lower 3 bytes of Serial number, 4 bytes data

Message	Response to Message	Response MUX ID	P0	P1	P2	P3	P4	P5	P6
User P/W	Set User P/W Get User P/W	0xB6	<New P/W> 0x20 – 0x7e	<New P/W> 0x20 – 0x7e	<New P/W> 0x20 – 0x7e	<New P/W> 0x20 – 0x7e	<New P/W> 0x20 – 0x7e	<New P/W> 0x20 – 0x7e	0x00

Table 50: User P/W

Only of activated mode

6.10. Multiplexed Response – messages (control)

Message	Response to Message	Response MUX ID	P0	P1	P2	P3	P4	P5	P6
Reset	Reset	0xD0	<Reset option > 0x01 – Reset all parameters to default 0x02 – Force hard reset	0x00	0x00	0x00	0x00	0x00	0x00

Table 51: Reset

Send right before reset

Message	Response to Message	Response MUX ID	P0	P1	P2	P3	P4	P5	P6
Goto sleep	Goto Sleep	0xD1	<Wakeup source as bitfield> 0b0000 0001 – timer 0b0000 0010 – I-threshold 0b0000 0100 – Ah - threshold	<Timer value[1 s]> Unsigned 16 bit 0 s – 65000 s		<I – threshold [1 mA]> Unsigned 16 bit 0 mA to 250 mA		<Ah – threshold [1 mAs]> Unsigned 16 bit 0 mAs to 65000 mAs	

Table 52: Goto sleep

Send right before entering sleep mode

Message	Response to Message	Response MUX ID	P0	P1	P2	P3	P4	P5	P6
Store Settings	Store Settings	0xD4	0x00	0x00	0x00	0x00	0x00	0x00	0x00

Table 53: Store Settings

6.11. Multiplexed Response – messages (information)

Message	Response to Message	Response MUX ID	P0	P1	P2	P3	P4	P5	P6
Device ID	Get Device ID	0xE0	<Message counter multiframemessage> 0x00	0x49 (I)	0x43 (C)	0x44 (D)	0x2D (-)	Depending on variant 0x41 (A) 0x43 (C) 0x52 (R)	0x00

Table 54: Device ID

Device ID response includes 4 messages with message counter 0x00- 0x03

Message	Response to Message	Response MUX ID	P0	P1	P2	P3	P4	P5	P6
Device ID	Get Device ID	0xE0	<Message counter multiframemessage> 0x01	0x2D (-)	Depending on current range 0x30(0100A) 0x30(0300A) 0x30(0500A)	Depending on current range 0x31(0100A) 0x33(0300A) 0x35(0500A)	Depending on current range 0x30(0100A) 0x30(0300A) 0x30(0500A)	Depending on variant 0x30(0100A) 0x30(0300A) 0x30(0500A)	0x00

Table 55: Device ID

Device ID response includes 4 messages with message counter 0x00- 0x03

Message	Response to Message	Response MUX ID	P0	P1	P2	P3	P4	P5	P6
Device ID	Get Device ID	0xE0	<Message counter multiframemessage> 0x02	0x2D (-)	0x43 (C)	0x41 (A)	0x4E (N)	Depending on communication setup 0x31 (with termination) 0x32 (no termination) 0x33 (selectable termination)	0x00

Table 56: Device ID

Device ID response includes 4 messages with message counter 0x00- 0x03

Message	Response to Message	Response MUX ID	P0	P1	P2	P3	P4	P5	P6
Device ID	Get Device ID	0xE0	<Message counter multiframemessage> 0x03	0x2D (-)	Depending on supply voltage range 0x31 (12V)	Depending on supply voltage range 0x32 (12V)	0x00	0x00	0x00

Table 57: Device ID

Device ID response includes 4 messages with message counter 0x00- 0x03

Message	Response to Message	Response MUX ID	P0	P1	P2	P3	P4	P5	P6
F/W Version	Get FW Version	0xE1	<Major Version> 0x30 – 0x39	<Minor Version> 0x30 – 0x39	<Release Version> 0x30 – 0x39	0x00	0x00	0x00	0x00

Table 58: F/W Version

Message	Response to Message	Response MUX ID	P0	P1	P2	P3	P4	P5	P6
Serial number	Get Serial Number	0xE2	<Serial number> unsigned 32				0x00	0x00	0x00

Table 59: Serial number

Message	Response to Message	Response MUX ID	P0	P1	P2	P3	P4	P5	P6
H/W Version	Get H/W Version	0xE3	<Message counter multiframe message> 0x00	Identifier 0x49 (I)	Identifier 0x4D (M)	Depending on PCB no 0x30 – 0x39	Depending on PCB no 0x30 – 0x39	Depending on PCB no 0x30 – 0x39	Depending on layout version

Table 60: H/W version (1/2)

Device ID response includes 2 messages with message counter 0x00- 0x01

Message	Response to Message	Response MUX ID	P0	P1	P2	P3	P4	P5	P6
H/W Version	Get H/W Version	0xE3	<Message counter multiframe message> 0x01	0x5F (L)	0x41 (A)	Depending on BOM 0x30 – 0x39	Depending on BOM 0x30 – 0x39	Depending on BOM 0x30 – 0x39	Depending on BOM 0x30 – 0x39

Table 61: H/W version (2/2)

Device ID response includes 2 messages with message counter 0x00- 0x01

Message	Response to Message	Response MUX ID	P0	P1	P2	P3	P4	P5	P6
Article number	Get Article Number	0xE4	<Article number> unsigned 56 bit						

Table 62: Article number

Message	Response to Message	Response MUX ID	P0	P1	P2	P3	P4	P5	P6
Revision	Get Revision	0xE5	0x52 (R)	0x45 (E)	0x56 (V)	Depending on BOM 0x30 – 0x39	Depending on BOM 0x30 – 0x39	Depending on BOM 0x30 – 0x39	Depending on BOM 0x30 – 0x39

Table 63: Revision

Message	Response to Message	Response MUX ID	P0	P1	P2	P3	P4	P5	P6
Up time	Get Up time	0xE6	<Up Time [minute]> unsigned 32 bit				0x00	0x00	0x00

Table 64: Up time // time of operation

Message	Response to Message	Response MUX ID	P0	P1	P2	P3	P4	P5	P6
Lifetime	Get Lifetime	0xE7	<Lifetime [minute]> unsigned 32 bit				0x00	0x00	0x00

Table 65: Lifetime

Message	Response to Message	Response MUX ID	P0	P1	P2	P3	P4	P5	P6
Status	Get Status Clear Status	0xE8	0x00	0x00	<measurement status> 16 bit 0b0000 0000 0000 0001 – adc interrupt 0b0000 0000 0000 0010 – overflow adc ch 1 0b0000 0000 0000 0100 – overflow adc ch 2 0b0000 0000 0000 1000 – overflow adc ch 3 0b0000 0000 0001 0000 – open circuit I 0b0000 0000 0010 0000 – open circuit U 0b0000 0000 0100 0000 – open circuit Tchip 0b0000 0000 1000 0000 – open circuit Text 0b0000 0001 0000 0000 – calibration data 0b0000 0010 0000 0000 – OCS active		<system status> 16 bit 0b0000 0000 0000 0001 – code crc 0b0000 0000 0000 0010 – calibration data crc 0b0000 0000 0000 0100 – CAN Rx 0b0000 0000 0000 1000 – CAN Tx 0b0000 0000 0001 0000 – overtemp 0b0000 0000 0010 0000 – undertemp 0b0000 0000 0100 0000 – power failure 0b0000 0000 1000 0000 – system clock 0b0000 0001 0000 0000 – system init 0b0000 0010 0000 0000 – configuration 0b0000 0100 0000 0000 – eeprom r/w 0b0000 1000 0000 0000 – power on reset 0b0001 0000 0000 0000 – low voltage reset 0b0010 0000 0000 0000 – ext. pin reset 0b0100 0000 0000 0000 – clock mon. reset 0b1000 0000 0000 0000 – COP WD reset		0x00

Table 66: Status

Message	Response to Message	Response MUX ID	P0	P1	P2	P3	P4	P5	P6
Event counter	Get Event Counter Clear Event Counter	0xEB	<Measurement event counter> 0x01 – adc interrupt 0x02 – overflow adc ch1 0x03 – overflow adc ch2 0x04 – overflow adc ch3 0x05 – open circuit I 0x06 – open circuit U 0x07 – open circuit Tchip 0x08 – open circuit Text 0x09 – calibration data 0x0a OCS active	<System event counter> 0x01 – code crc 0x02 – calibration data crc 0x03 – CAN Rx 0x04 – CAN Tx 0x05 – overtemp 0x06 – undertemp 0x07 – power failure 0x08 – system clock 0x09 – system init 0x0a – configuration 0x0b – eeprom r/w 0x10 – power on reset 0x20 – low voltage reset 0x30 – ext. pin reset 0x40 – clock mon. reset 0x50 – COP WD reset	<Event Counter Value Measurement > 0x0000 – 0xffff	<Event Counter Value System> 0x0000 – 0xffff	0 x 0 0		

Table 67: Event counter

Message	Response to Message	Response MUX ID	P0	P1	P2	P3	P4	P5	P6
Non valid command		0xFF	0x00	0x00	0x00	0x00	0x00	0x00	0x00

Table 68: Non valid command

Only send if command is not valid, within MUX ID

6.12. Result – message

The result message includes the signal information about current (*I*) and battery voltage (*U_{bat}*). Layout and the specific byte order are shown in the table below.

CAN msg result	ID	D0	D1	D2	D3	D4	D5	D6	D7
Message	0x502	Result values							
Result		<Message counter and Status>	<Result I> signed 32 bit				<Result Ubat> unsigned 16 bit		0x00

Table 69: result message – CAN frame

Data byte	High nibble (upper 4 byte)	Low nibble (lower 4 byte)
<D0>	<Message counter> 0x0 – 0xf (restart at 0x0 after 0xf)	<Status> 0b0000 – no issue 0b0001 – OCS 0b0010 – measurement error 0b0100 – system error

Table 70: Shared byte D0 within Result Message

The signal attributes of this message are fixed in the position. There is no multiplexor byte like in the messages *cmd* and *response*.

6.13. Access-Mode / Storing and reset

The following Table shows in which Access-Mode the user has access to which related command. Also it can be seen which command related parameter is stored by the Store command and Reset to the default value by the Reset command.

Message	MUX ID	Access Mode 0x00	Access Mode 0x01	storing / Reset to default
Trigger Result	0x00	x	x	
Get Result Temperature	0x01	x	x	
Get Result Ah Counter	0x02	x	x	
Set Operation Mode	0x10	x	x	x / x
Get Operation Mode	0x60	x	x	x / x
Set Access Mode (user access)	0x11	x	x	
Set Access Mode (user access)	0x11	x	x	
Set Access Mode (user access)	0x11	x	x	
Get Access Mode (user access)	0x61	x	x	
Set Averaging	0x20		x	x / x
Get Averaging	0x70		x	x / x
Set OC limit	0x21		x	x / x
Get OC limit	0x71		x	x / x
Set CAN configuration	0x22		x	x / x
Get CAN configuration	0x72		x	x / x
Set CAN ID request	0x23		x	x / x
Get CAN ID request	0x73		x	x / x
Set CAN ID response	0x24		x	x / x
Get CAN ID response	0x74		x	x / x
Set CAN ID result	0x25		x	x / x
Get CAN ID result	0x75		x	x / x
Set user PW only in related mode	0x26		x	x / x
Get user PW only in related mode	0x76		x	x / x
Reset	0x40		x	
Goto Sleep	0x41	x	x	
Clear Ah Counter	0x42	x	x	
Clear status Bits	0x43	x	x	
store setting (Trigger mode, CAN config, averaging, CAN ID, Result struct)	0x44		x	
Clear Event Counter	0x45	x	x	
Get Device ID	0x50	x	x	
Get FW Version	0x51	x	x	
Get Serial no.	0x52	x	x	
Get HW Version	0x53	x	x	
Get Article No.	0x54	x	x	
Get Revision	0x55	x	x	
Get up time	0x56	x	x	x / x
Get lifetime counter	0x57	x	x	
Get status Bits	0x58	x	x	
Get CRC Code	0x59		x	
Get CRC calibration Data	0x5a		x	
Get Event Counters	0x5B	x	x	

Table 71: Table access mode / storing and reset

6.14. Default values

If using the Reset command with parameter 0x01 (reset all parameters to default) the following values are reset to its related default value.

Message	Parameter	Value
Operation Mode	Mode Output rate Current direction	0x01 - continues 0x01 - 1 ms 0x00 - positive
Result Ah Counter	Ah-Counter value	0x00 - 0 mAs
Averaging	Average value	0x01 - 1
OC limit	Activation limit positive Activation limit negative	0x00 00 00 0x00 00 00
CAN configuration	Baudrate CAN mode	0x01 - 500k Baud 0x00 – 2.0 a
CAN ID request	CAN ID	0x500
CAN ID response	CAN ID	0x501
CAN ID result	CAN ID	0x502
User PW	Mode 0x01	0x30; 0x30; 0x30; 0x30; 0x30; 0x30
Result MSG Structure	Result MSG Structure value	0x00 - UBat
Up time	Up time value	0x00 00 00 00
Status Bits	Measurement status bits value System status bits value	0x00 00 0x00 00
Event Counter	All measurement counter values All system counter values	0x00 00 0x00 00

Table 72: Default values

6.15. Startup Messages

During startup the sensors indicated that it is working with several messages. After sending these messages the sensor is fully functional. All Messages are send within a response message (0x501 by default), one by one.

Message no.	Message	MUX ID	Remark
1	Device ID	0xE0	4 Messages with message counter (P0) 0x00 to 0x03
2	Serial Number	0xE2	
3	F/W Version	0xE1	

Table 73: Startup messages

7. Qualification

7.1. MBN LV 124-2, 2009-11 / DIN 40 050-9

Mechanical tests	Description	Profile	Parameter
M-01	Free fall		
M-04	Vibration test	Vibration profile D	

Climatic tests	Description	Profile	Parameter
K-05	Temperature shock		$\Delta T_{FIELD} = 34K$ $T_{MIN} = -40^{\circ}C$ $T_{MAX} = 125^{\circ}C$ Period of application = 10 years Cycles for 10 years = 7300 (2*Day)
K-14	Humid heat	SG2	$T_{FIELD} = 23^{\circ}C$ $RH_{FIELD} = 65\%$ $T_{TEST} = 65^{\circ}C$ $RH_{TEST} = 93\%$ Period of application = 10 years

Life test	Description	Profile	Parameter
L-03	Life test – temperature cycle test		$\Delta T_{FIELD} = 34K$ $T_{MIN} = -40^{\circ}C$ $T_{MAX} = 105^{\circ}C$ Period of application = 10 years Cycles for 10 years = 7300
---	Storage		$T_{TEST} = 125^{\circ}C$ TD according to IMC-M Storage time = 10 years
L-02	Life test – high-temperature endurance test		$T_{TEST} = 105^{\circ}C$ TD: [-40,2],[23,20],[50,74],[80,3],[105,1] Period of application = 10 years (see Storage) Application within the lifetime = 20000h $E_a = 0.45eV$

IP Class	Description	Profile	Parameter
Number 1 (DIN 40050 Part 9)	Dust-tight	6k	
Number 2 (DIN 40050 Part 9)	Protected against water	0	

7.2. ISO 16750-2:2003

Description
Supply voltage
Overvoltage
Superimposed alternating voltage
Slow decrease and increase of supply voltage
Momentary drop in supply voltage
Reset behaviour at voltage drop
Starting profile
Open circuit tests
Reversed voltage

7.3. ISO 7637-2:2004 (ICD-A)

Description
Transient Voltage emissions
Impulse 1
Impulse 2a / 2b
Impulse 3a / 3b
Impulse 4
Impulse 5a / 5b

7.4. ISO 10605:2008 (ICD-A)

Description
Contact discharge (direct and indirect)
Air discharge (direct and indirect)
handling and packaging discharge

7.5. ISO 11452-2 (ICD-A)

Description	Range	Parameter
Immunity to radiated electromagnetic fields	80 MHz – 2 GHz	100 V/m

7.6. EN 55025 (ICD-A)

Description	Range	Result
Interference field strength	150 kHz - 2,5 GHz	Class 3
Interference voltage on vehicle power supply	150 kHz – 108 MHz	Class 3
interference current on signal line and control line	150 kHz – 108 MHz	Class 3

7.7. IEC/EN 61000-4-2 (ICD-C)

Description	Parameter
Contact discharge (direct and indirect)	4 kV

7.8. IEC/EN 61000-6-2 (ICD-C)

Description	Range	Parameter
Immunity to radiated electromagnetic fields	80 MHz – 2.7 GHz	10 V/m 3 V/m

7.9. EN 55011 (ICD-C)

Description
interference field strength
Interference voltage on supply voltage
Interference current on signal line and control line