

Title	<i>Reference Design Report for a 300 W 3-Phase Inverter Using BridgeSwitch™ BRD1265C and LinkSwitch™-TN2 LNK3204D in FOC Operation</i>
Specification	340 VDC Input, 300 W Continuous Three-Phase Inverter Output Power, 0.92 A _{RMS} Continuous Motor Phase Current
Application	High-Voltage Brushless DC (BLDC) Motor Drive
Author	Applications Engineering Department
Document No.	RDR-853
Date	June 16, 2022
Revision	1.3

Summary and Features

- BridgeSwitch – high-voltage half-bridge motor driver
- Integrated 600 V FREDFETs with ultra-soft, fast recovery diodes
- No heat sink
- Fully self-biased operation – simplifies auxiliary power supply but can also support external bias operation as needed
- High-side and low-side cycle-by-cycle current limit
- Two level device over-temperature protection
- High-voltage bus monitor with four undervoltage threshold and one overvoltage threshold
- System level temperature monitor
- Single wire status update communication bus
- Supports any microcontroller (MCU) for sensorless field-oriented control (FOC) through the signal interface
- Instantaneous phase current output signal for each BridgeSwitch
- Fault reporting for each device through the FAULT BUS pin on the interface.
- +5 V supply ready through the interface

PATENT INFORMATION

The products and applications illustrated herein (including transformer construction and circuits external to the products) may be covered by one or more U.S. and foreign patents, or potentially by pending U.S. and foreign patent applications assigned to Power Integrations. A complete list of Power Integrations' patents may be found at www.power.com. Power Integrations grants its customers a license under certain patent rights as set forth at <https://www.power.com/company/intellectual-property-licensing/>.



Table of Contents

1	Introduction.....	5
2	Inverter Specification.....	7
3	Schematic.....	8
4	Circuit Description	12
4.1	Three-Phase BridgeSwitch Inverter	12
4.2	Input Stage.....	12
4.3	BridgeSwitch Bias Supply	12
4.4	PWM Input.....	13
4.5	Cycle-by-Cycle Current Limit.....	13
4.6	System Underoltage (UV) and Overvoltage (OV) Protection.....	13
4.7	System Level Temperature and Monitoring.....	13
4.8	Fault Bus.....	13
4.9	Device ID.....	13
4.10	Microcontroller (MCU) Interface.....	13
4.11	External Supply	14
4.12	Three-Phase Motor Interface.....	14
4.13	Auxiliary Power Supply Circuit.....	14
4.14	+5 V Linear Regulator.....	14
4.15	Current Sense Amplifier	14
5	Printed Circuit Board Layout.....	15
6	Bill of Materials	17
7	Performance Data	18
7.1	Start-Up Operation	18
7.1.1	BPL and BPH Start-Up Waveforms.....	18
7.1.2	Motor Start-Up Waveforms	19
7.2	Steady-State Operation	20
7.2.1	Phase Voltages (Drain-to-Source) During Steady-State.....	20
7.2.2	High-Side Drain-to-Source Voltage Slew Rate	21
7.2.3	Phase Currents During Steady-State.....	22
7.2.4	INL and /INH Signals	23
7.2.5	BPL and BPH during Steady-State	24
7.3	Thermal Performance.....	25
7.3.1	100 W Loading Condition (315 mA Average Motor Phase Current)	26
7.3.2	200 W Loading Condition (620 mA Average Motor Phase Current)	26
7.3.3	300 W Loading Condition (915 mA Average Motor Phase Current)	27
7.3.4	Thermal Scan Summary Table	27
7.3.4.1	Self Supply Mode.....	27
7.3.4.2	External Supply Mode	27
7.4	No-Load Input Power Consumption.....	28
7.5	Efficiency	29
7.5.1	Efficiency Table at Self Supply Mode	30
7.5.2	Efficiency Table at External Supply Mode.....	30
7.6	Device and System Level Protection / Monitoring.....	31



7.6.1	Overcurrent Protection (OCP)	31
7.6.2	Thermal Warning	32
7.6.3	Thermal Shutdown.....	33
7.6.4	Undervoltage (UV)	34
7.6.5	Overvoltage (OV).....	35
7.6.6	System Thermal Fault	36
7.7	Abnormal Motor Operation Test.....	37
7.7.1	Operation Under Stalled (Motor) Conditions.....	37
7.7.2	Operation with One Motor Phase / Winding Disconnected.....	38
7.7.3	Running Overload Test.....	40
8	Appendix	41
8.1	Board Quick Reference.....	41
8.1.1	The Microcontroller (MCU) Interface Contains the Following Pins / Signals	41
8.1.2	J4 Connector Pin Designation.....	42
8.1.3	J5 Connector Pin Designation.....	42
8.2	Recommended Start-up Sequence	43
8.3	Status Word Encoding.....	44
8.4	Suggested Microcontroller Actions to BridgeSwitch Fault Conditions.....	45
8.5	Inverter Output Power Measurement	46
8.6	Current Capability vs. Ambient Temperature	47
8.7	Efficiency Curves at Different Switching Frequencies.....	48
8.8	Test Bench Set-up	49
8.8.1	Equipment Used	50
9	Revision History	51

Important Note:

During operation, the reference design board is subject to hazards including high voltages, rotating parts, bare wires, and hot surfaces. Energized DC bus capacitors require time to discharge after DC input disconnection.

All testing should use an isolation transformer to provide the DC input to the board.



1 Introduction

This document describes a 300 W, 97% efficient, three-phase inverter for high-voltage brushless DC (BLDC) motor application using three BridgeSwitch BRD1265C devices. The design shows the device performance, internal level monitoring, system level monitoring, and fault protection facilitated by the high level of integration of the BridgeSwitch half-bridge motor driver IC. A high-voltage, low component count buck converter utilizing a LinkSwitch-TN2 LNK3204D device supplies the current sense amplifier and optionally provides external bias for the BridgeSwitch devices.

Also included in this report are the inverter specifications, schematic, bill of materials, printed circuit board (PCB) layout, performance data, and test setup. The provided waveforms and design performance are based on a sensorless field-oriented control (FOC) method employing the Space Vector Modulation (SVM) scheme commonly referred to as three-phase modulation in this document.

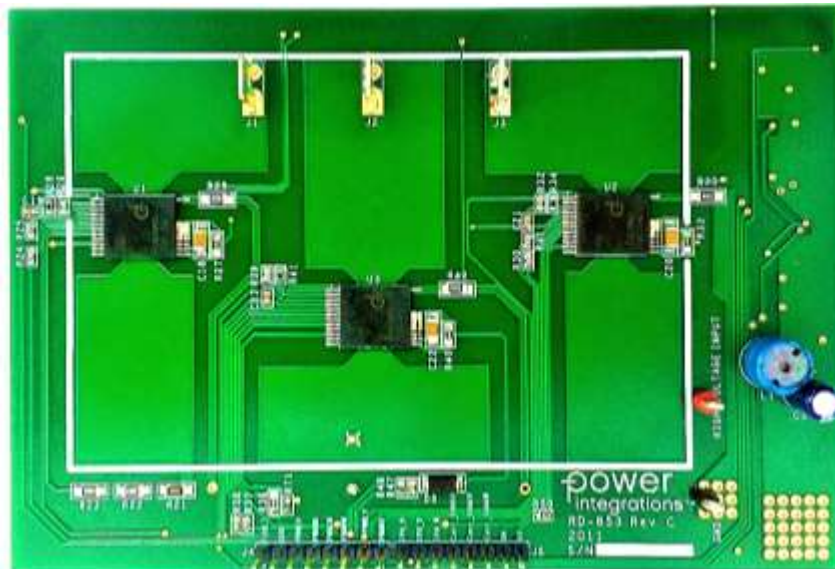

Figure 1 – Populated Circuit Board Top View.

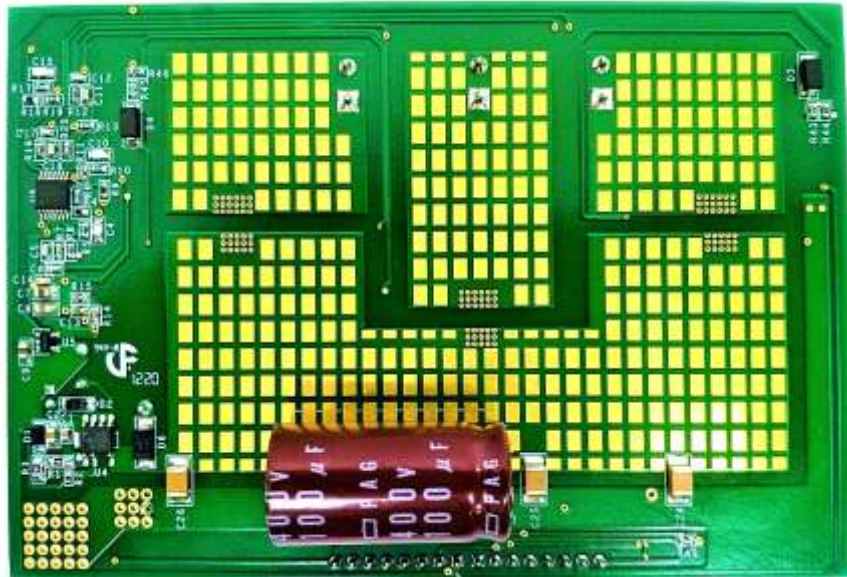

Figure 2 – Populated Circuit Board Bottom View.

2 Inverter Specification

The table below provides the electrical specification of the three-phase inverter design. The result section provides actual performance data.

Description	Symbol	Min	Typ	Max	Unit	Comment
Input						
Voltage	V_{IN}	270	340	365	V	2-Wire DC Input.
Current	I_{IN}		0.91		A _{RMS}	RMS
Power	P_{IN}		309		W	At Efficiency = 97%.
Output						
Power	P_{OUT}		300		W	Inverter Output Power
Motor Phase Current	$I_{MOT(RMS)}$		0.92		A _{RMS}	Continuous RMS per Phase.
Inverter Peak Output Current	$I_{INT(PK)}$		3		A	Inverter Peak Current.
PWM Carrier Frequency ¹	f_{PWM}		12	16	kHz	Three-Phase FOC Modulation.
Efficiency	η		97		%	Self-Supplied Operation.
Output Speed	ω		5000		RPM	Motor Speed at 300 W Inverter Output.
Environmental						
Ambient Temperature	T_{AMB}	-20	28	65	°C	Average Ambient Temperature. Closed-case. Free Convection.
Device Case Temperature	$T_{PACKAGE}$		87	124	°C	0.92 A _{RMS} Phase Current in Self-Supplied Operation.
System Level Monitoring						
DC Bus Sensing						Reported through Status Communication Bus (FAULT Pin).
OV Threshold	V_{OV}		422		V	
1 st UV Threshold	V_{UV100}		247		V	
2 nd UV Threshold	V_{UV85}		212		V	
3 rd UV Threshold	V_{UV60}		177		V	
4 th UV Threshold	V_{UV55}		142		V	
Over Current Protection ²	I_{OCP}		3		A _{PK}	At XL/XH = 44.2 kΩ
System Warning Temperature ³	T_{SYS}		90		°C	
Notes: 1. 20 kHz is the maximum recommended PWM frequency with self-supply or with external supply. 2. This can be manually configured by adjusting the value of the XL/XH resistors. For BRD1265C, the maximum current protection level is 1 A at an XL/XH resistance of 44.2 kΩ. 3. Sensed through an external thermistor, the temperature threshold depends on the chosen NTC and its location (requires verification in final application).						
Table 1 – Inverter Specification.						



3 Schematic

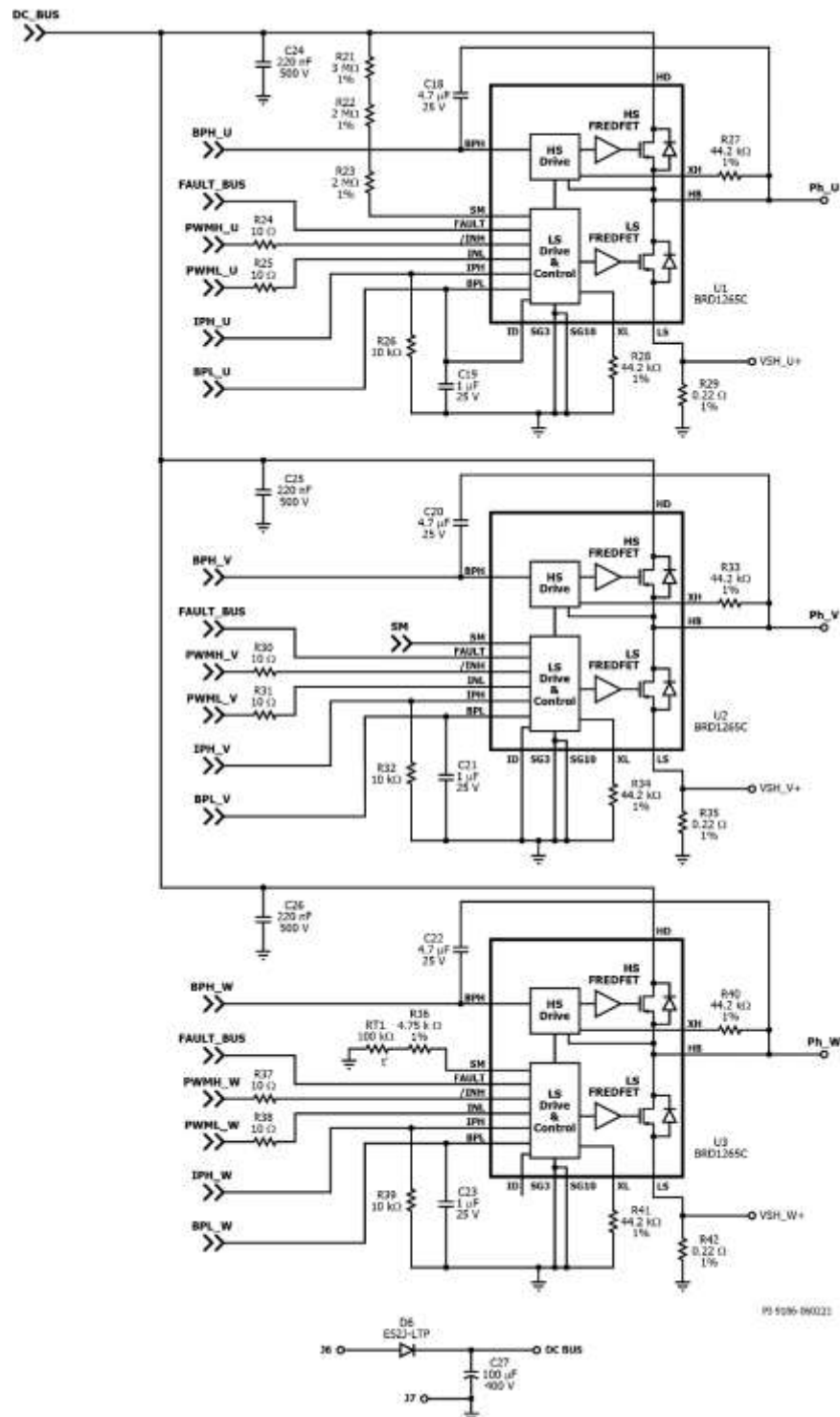

Figure 3 – BridgeSwitch Three-Phase Inverter Circuit Schematic.



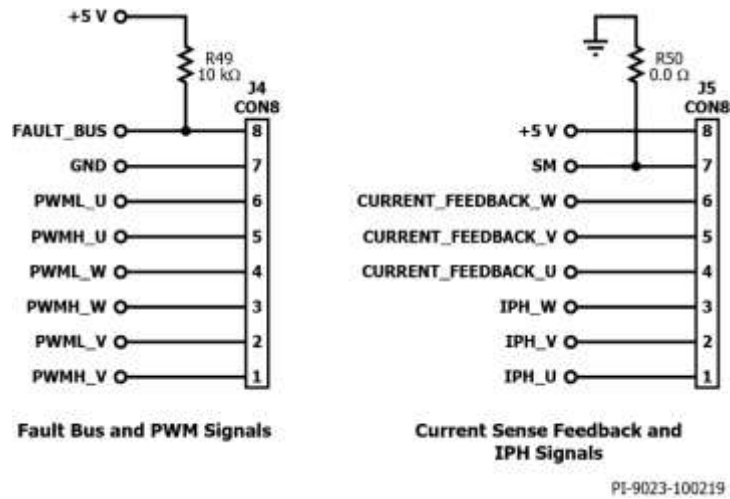

Figure 4 – Microcontroller Interface Schematic.

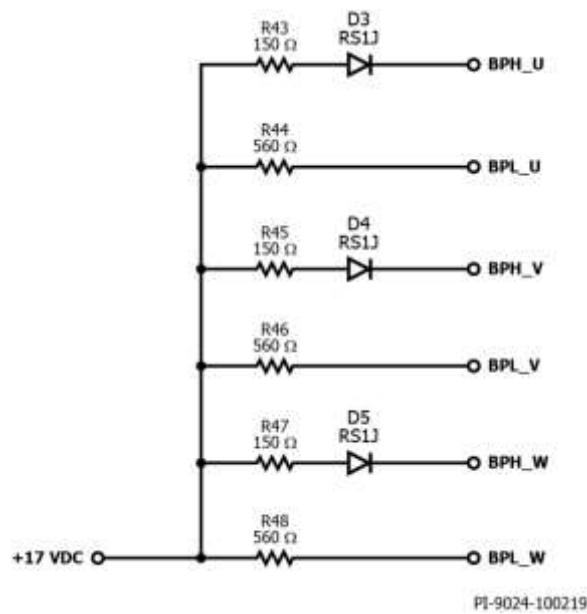

Figure 5 – External Supply Schematic.



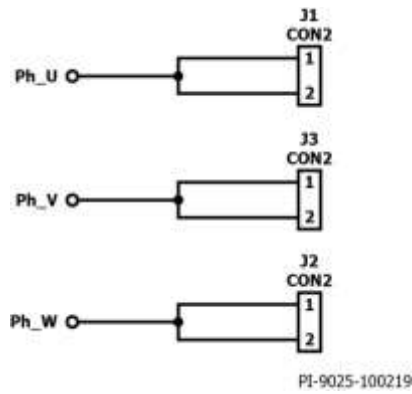

Figure 6 – Three-Phase Motor Interface Schematic.

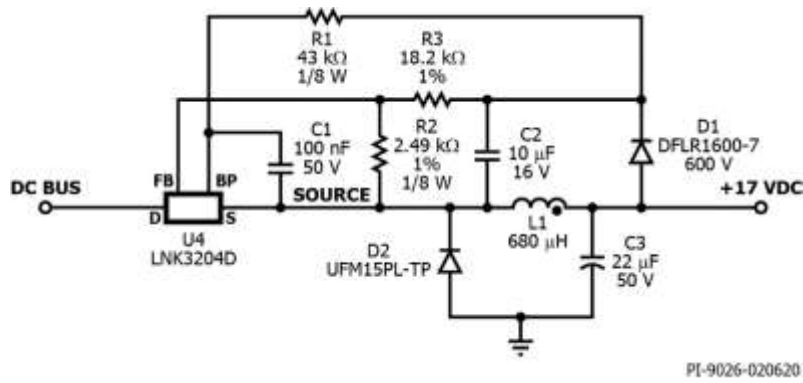

Figure 7 – Auxiliary Circuit Schematic.

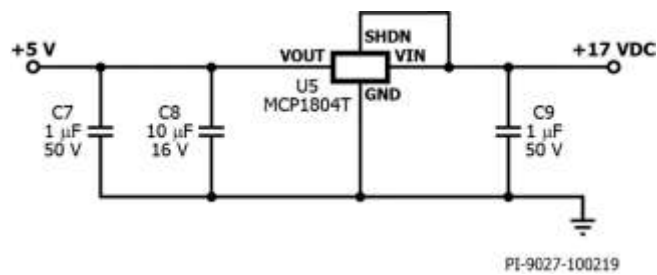

Figure 8 – +5 V Linear Regulator Schematic.

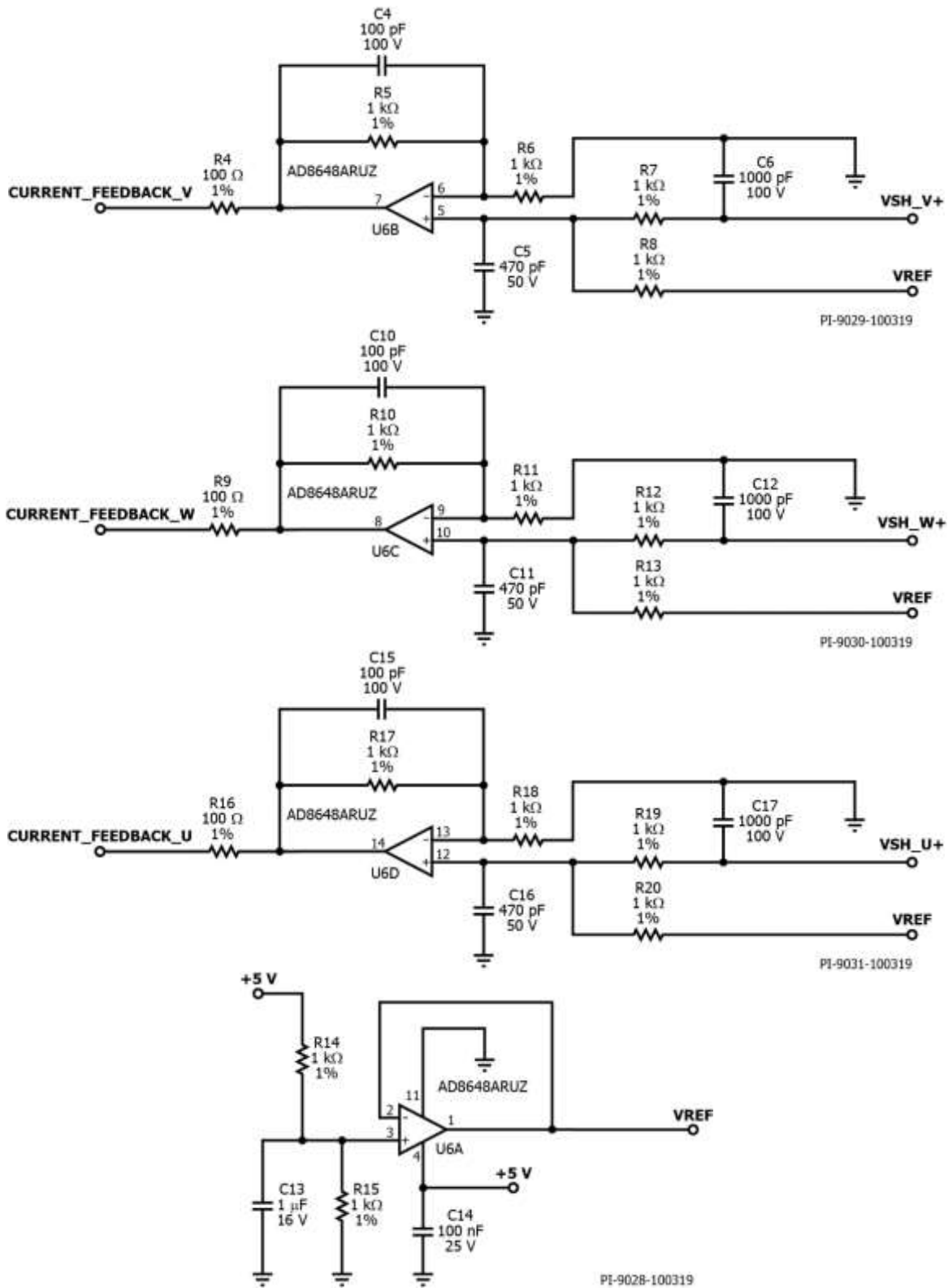

Figure 9 – Current Sense Amplifier Circuit Schematic.



4 Circuit Description

The overall schematic shows a three-phase inverter utilizing three BridgeSwitch BRD1265C devices. The circuit design drives a high-voltage, three-phase, brushless DC (BLDC) motor utilizing field-oriented control (FOC) for driving the motor. The BridgeSwitch IC combines two 600 V, N-channel power FREDFETs with their corresponding gate drivers into a low profile surface mount package. The BridgeSwitch power FREDFET features an ultra-soft, fast recovery diode ideally suited for inverter drives. Both drivers are fully self-supplied eliminating the need for the system power supply to provide gate drive power.

A LinkSwitch-TN2 LNK3204D device in a high-voltage buck converter configuration provides an optional +17 V supply for the BridgeSwitch device (external bias) and input DC voltage for the +5 V linear regulator that supplies the current sense amplifier circuit.

In addition, the BridgeSwitch IC incorporates internal fault protection and system level monitoring. Internal fault protection includes cycle-by-cycle current limit for both FREDFETs and a two level thermal overload protection. On the other hand, system level monitoring includes high-voltage DC bus sensing with multi-level undervoltage thresholds and one overvoltage threshold. The BridgeSwitch IC can also be configured using external sensors such as a thermistor for system temperature monitoring. A single wire open drain bus communicates all detected fault or change of status to the system microcontroller.

4.1 *Three-Phase BridgeSwitch Inverter*

The three BridgeSwitch devices U1, U2, and U3 form the three-phase inverter. The output of the inverter connects to the three-phase BLDC motor through connectors J1, J2, and J3.

4.2 *Input Stage*

The input stage consists of terminals J6 and J7, input diode D6, and bulk capacitor C27. Terminals J6 (positive terminal) and J7 (negative terminal) serve as connectors for the high-voltage DC bus. The bulk capacitor C27 minimizes the path for the high-voltage DC input from the supply to the board. It is protected by input diode D6 from reversed DC voltage in the case of the DC input connections being swapped.

4.3 *BridgeSwitch Bias Supply*

Capacitors C19, C21, and C23 provide self-supply decoupling for the integrated low-side controller and gate driver. An internal high-voltage current source recharges these capacitors as soon as the voltage level starts to dip. On the other hand, capacitors C18, C20, and C12 provide self-supply decoupling for the integrated high-side controller and gate driver. Internal high-voltage current sources recharge these capacitors whenever the half-bridge point of the respective device drops to the low-side source voltage level (i.e. the low-side FREDFET turns on).



4.4 **PWM Input**

Input PWM signals PWML_U, PWMH_U, PWML_V, PWMH_V, PWML_W, PWMH_W, control the switching state of the integrated high-side and low-side power FREDFETs. The system microcontroller provides the required PWM signal and desired switching frequency.

4.5 **Cycle-by-Cycle Current Limit**

Resistors R28, R34, R41, R27, R33, and R40 set the cycle-by-cycle current limit level for the integrated low-side and high-side power FREDFETs. A selected value of 44.2 k Ω set the current limit to 100% of the default level or 3 A_{PK}.

4.6 **System Undervoltage (UV) and Overvoltage (OV) Protection**

The BridgeSwitch device (U1) monitors the DC bus voltage through resistors R21 (3 M Ω), R22 (2 M Ω), and R23 (2 M Ω). The combined resistance of 7 M Ω sets the undervoltage thresholds to 247 V, 212 V, 177 V, and 142 V. The bus overvoltage threshold is at 422 V. The FAULT pin reports any detected bus voltage fault condition.

4.7 **System Level Temperature and Monitoring**

The BridgeSwitch device (U3) monitors the system temperature through thermistor RT1 connected to the SM pin. Resistor R36 tunes the threshold for a system level fault of 90 °C. The device reports a detected status change of the externally set system level temperature through the FAULT pin.

4.8 **Fault Bus**

The BridgeSwitch devices (U1, U2, and U3) reports any detected internal and system status change through pin 8 of connector J4. The system microcontroller can take action in accordance to the status update reported by the device. Such action could be for instance inverter shutdown, latch, restart, warning, etc.

4.9 **Device ID**

Each BRD1265C assigns itself a unique device ID through the connection of pin 11 (ID pin). The pin can be floating, connected to the SG pin, or connected to the BPL pin. The device ID allows the specific device flagging a fault to communicate its physical location to the system microcontroller.

4.10 **Microcontroller (MCU) Interface**

Connectors J4 and J5 serve as an interface between the system microcontroller and the BridgeSwitch three-phase inverter which contains the following signals:

- **FAULT_BUS** – Pin dedicated for fault reporting of all BridgeSwitch devices.
- **GND** – Common ground interface between the microcontroller and the inverter board.
- **PWMH_U, PWML_U, PWMH_V, PWML_V, PWMH_W, and PWML_W** – PWM input signal interface from the system microcontroller to the BridgeSwitch device.



- **+5 V** – Voltage supply pin for the microcontroller as needed.
- **SM** – Configurable system monitoring pin for the BridgeSwitch device (U2).
- **Curr_fdbkU, Curr_fdbkV, Curr_fdbkW** – Current feedback information needed by the microcontroller (MCU). This signal directly comes from the inverter current sense resistor passing through the current sense amplifier circuit.
- **IPH_U, IPH_V, IPH_W** – Instantaneous phase current information of the low-side power FREDFET Drain-to-Source current of each BridgeSwitch device coming from the IPH pin.

4.11 **External Supply**

Components R43, R44, R45, R46, R47, R48 and diodes D3, D4, and D5 are responsible for providing external supply to the BridgeSwitch BPL/BPH pin through device U4. External supply operation is optional for applications that require lower inverter no-load input power or operate at elevated ambient temperatures. Otherwise, these resistor and diode components can be depopulated. If depopulated, BPL/BPH supply will be drawn internally through the BridgeSwitch device (self-supply).

4.12 **Three-Phase Motor Interface**

Connectors J1, J2, and J3 are mechanical connectors that directly connect the BridgeSwitch three-phase inverter to the BLDC motor.

4.13 **Auxiliary Power Supply Circuit**

Device U4 (LNK3204D) is a high-side buck switcher IC responsible for providing optional +17 V supply for BPL/BPH (external bias) and +5 V linear regulator. It directly steps down the high input DC voltage to the desired low output voltage. For more information about LNK3204D, please refer to the datasheet through the following link:

<https://ac-dc.power.com/design-support/product-documents/data-sheets/linkswitch-tn2-data-sheet/>

4.14 **+5 V Linear Regulator**

Device U5 (MCP1804T) is a +5 V linear regulator that provides DC supply to the current sense amplifier circuit. It can also be used to supply an external microcontroller through pin 8 of connector J5.

4.15 **Current Sense Amplifier**

Components U6B, U6C, and U6D are current sense amplifiers, which receive data from sense resistors R29, R34, and R42. The current information from these sense resistors are offset to 2.5 VDC level in the current sense op-amp output pins. The U6A circuit provides the 2.5 VDC offset reference voltage. The current information from the output of U6B, U6C, and U6D are sent to the microcontroller (MCU) which modulates the PWM input to the BridgeSwitch inverter maintaining the desired power and RPM.

Note: U6A, U6B, U6C, and U6D are op-amps in one IC package (Quad op-amp, U6)



5 Printed Circuit Board Layout

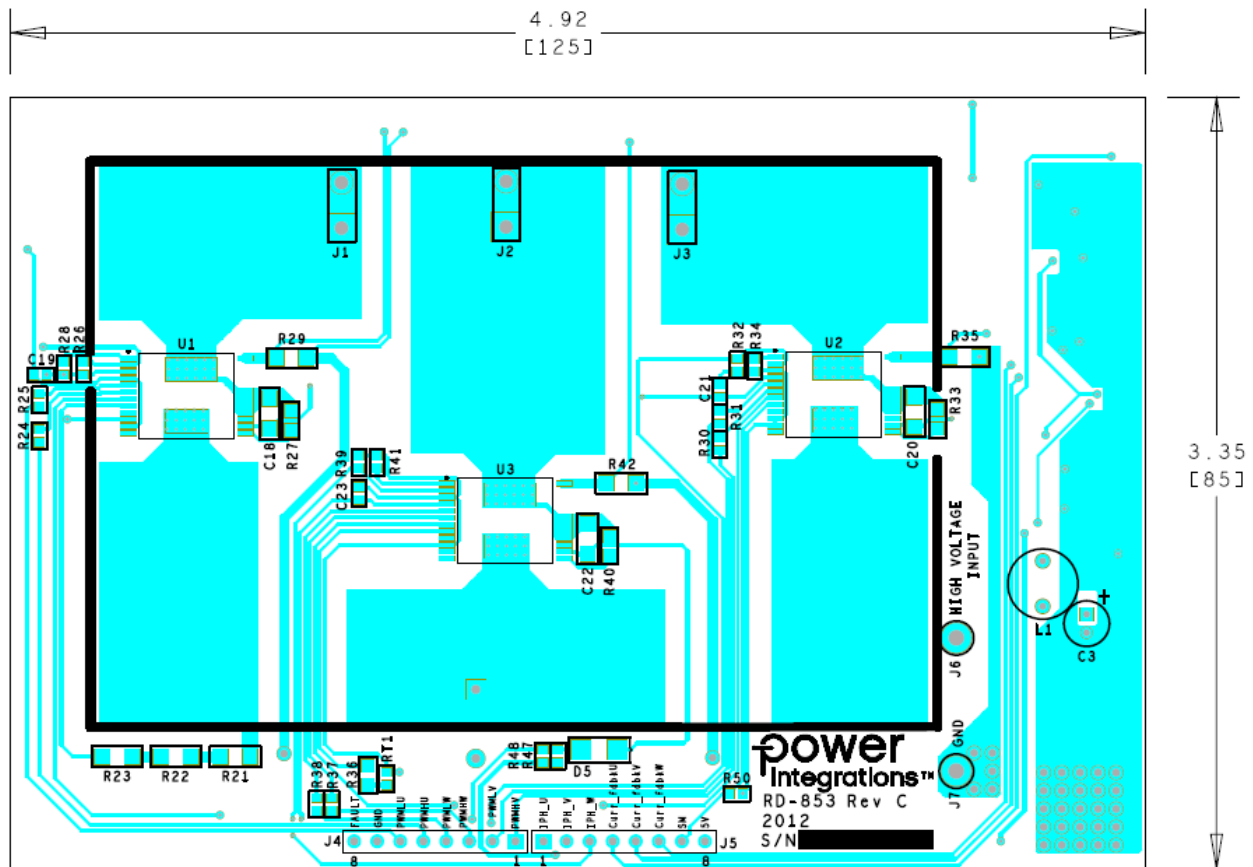

Figure 10 – Printed Circuit Board Layout (Top View).

Note:

1. The overall PCB dimension is 125mm X 85mm (L X W).
2. The inverter PCB dimension is 90mm x 60mm (L X W) – in black rectangle.
3. PCB Specifications:
 - Board thickness: 0.047 inches
 - Board material: FR4
 - Copper weight: 2 oz
 - No. of layers: 2



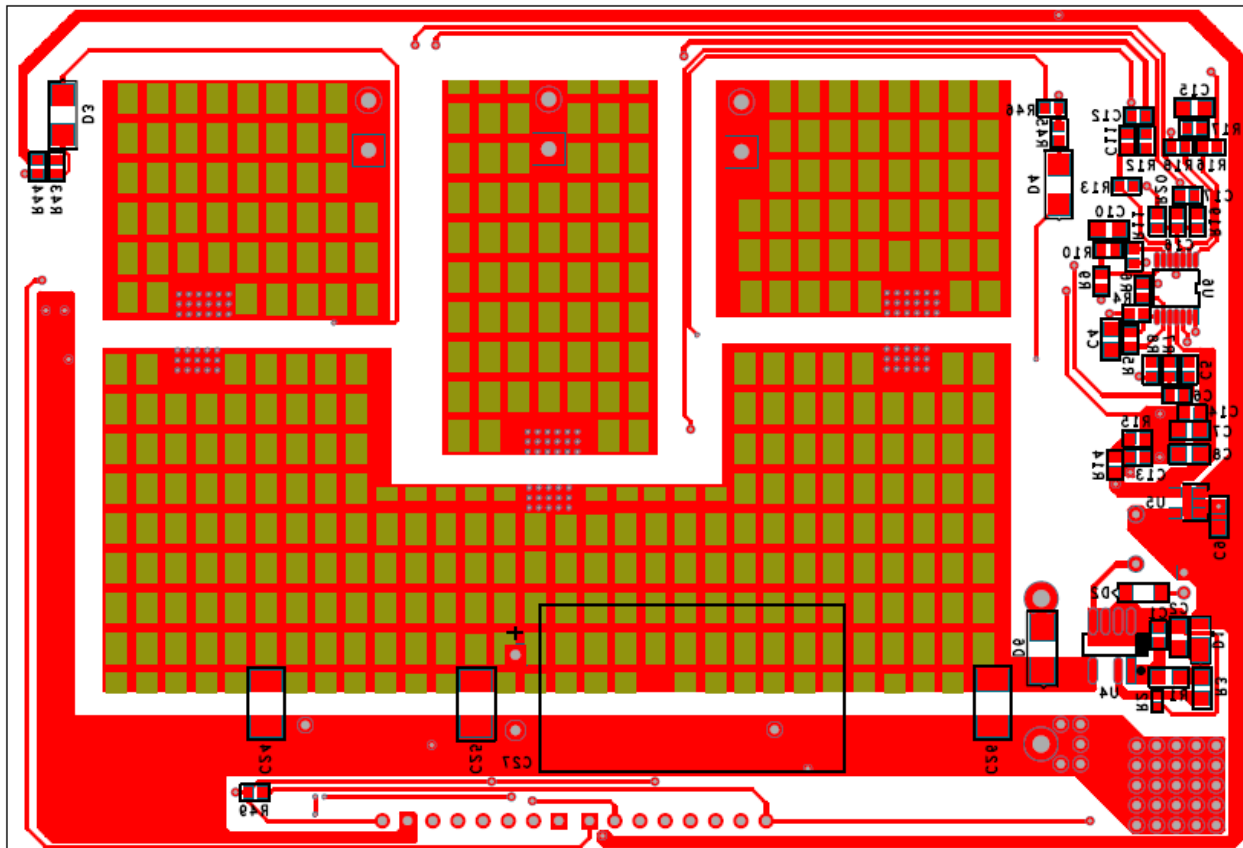

Figure 11 – Printed Circuit Board Layout (Bottom View).

Note:

1. The overall PCB dimension is 125mm X 85mm (L X W).
2. The inverter PCB dimension is 90mm x 60mm (L X W).
3. PCB Specifications:
 - Board thickness: 0.047 inches
 - Board material: FR4
 - Copper weight: 2 oz
 - No. of layers: 2

6 Bill of Materials

Item	Qty	Ref Des	Description	Mfg Part Number	Mfg
1	1	C1	100 nF, ±10%, 50 V, Ceramic, X7R, 0603	CGA3E2X7R1H104K080AA	TDK
2	2	C2,C8	10 µF, ±10%, 16 V, X7R, Ceramic, SMT, MLCC 0805	CL21B106KOQNNNE	Samsung
3	1	C3	22 µF, 50 V, Electrolytic, (5 x 11)	UPW1H220MDD	Nichicon
4	3	C4,C10,C15	100 pF, 100 V, Ceramic, COG, 0805	C0805C101J1GACTU	Kemet
5	3	C5,C11,C16	470 pF 50 V, Ceramic, COG/NP0, 0603	VJ0603A471JXAAC	Vishay
6	3	C6,C12,C17	1000 pF, 100 V, Ceramic, NP0, 0603	C1608C0G2A102J	TDK
7	2	C7,C9	1 µF, 50 V, Ceramic, X5R, 0805	08055D105KAT2A	AVX
8	1	C13	1 µF 16 V, Ceramic, X7R,0603	CL10B105K08VPNC	Samsung
9	1	C14	100 nF, 25 V, Ceramic, X7R, 0603	VJ0603Y104KXXAC	Vishay
10	3	C18,C20,C22	4.7 µF, ±10%, 25 V, Ceramic, X7R, 1206	GCM31CR71E475KA55L	Murata
11	3	C19,C21,C23	1 µF, ±10%, 25 V, Ceramic, X7R, 0603	CGA3E1X7R1E105K080AE	TDK
12	3	C24,C25,C26	220 nF, 500 V, Ceramic, X7R, 1812	C1812C224KCRCTU	Kemet
13	1	C27	100 µF, 400 V, Electrolytic, Low ESR, (16 x 30)	EPAG401ELL101ML30S	Nippon Chemi-Con
14	1	D1	600 V, 1 A, Rectifier, Glass Passivated, POWERDI123	DFLR1600-7	Diodes, Inc.
15	1	D2	600 V, 1 A, Ultrafast Recovery, 75 ns, SOD-123	UFM15PL-TP	Micro Commercial
16	3	D3,D4,D5	600 V, 1 A, Fast Recovery, 250 ns, SMA	RS1J-13-F	Diodes, Inc.
17	1	D6	600 V, 2 A, Super Fast, 35 ns, DO-214AC, SMA	ES2J-LTP	Micro Commercial
18	3	J1,J2,J3	CONN QC TAB 0.250 SOLDER	1287-ST	KeyStone
19	2	J4,J5	8 Pos (1 x 8) header, 0.1 pitch, Vertical, Au	P9101-08-D32-1	Protectron
20	1	J6	Test Point, RED, Thru-hole Mount	5010	Keystone
21	1	J7	Test Point, BLK, Thru-hole Mount	5011	Keystone
22	1	L1	680 µH, 0.36 A	SBC3-681-361	SUNX
23	1	R1	RES, 43 kΩ, 5%, 1/8 W, Thick Film, 0805	ERJ-6GEYJ433V	Panasonic
24	1	R2	RES, 2.49 kΩ, 1%, 1/10 W, Thick Film, 0402	ERJ-2RK2491X	Panasonic
25	1	R3	RES, 18.2 kΩ, 1%, 1/8 W, Thick Film, 0805	ERJ-6ENF1822V	Panasonic
26	3	R4,R9,R16	RES, 100 Ω, 1%, 1/16 W, Thick Film, 0603	ERJ-3EKF1000V	Panasonic
27	14	R5,R6,R7,R8, R10,R11,R12, R13,R14,R15, R17,R18,R19, R20	RES, 1 kΩ, 1%, 1/16 W, Thick Film, 0603	ERJ-3EKF1001V	Panasonic
28	1	R21	RES, 3 MΩ, 1%, 1/4 W, Thick Film, 1206	KTR18EZPF3004	Rohm Semi
29	2	R22,R23	RES, 2.00 MΩ, 1%, 1/4 W, Thick Film, 1206	ERJ-8ENF2004V	Panasonic
30	6	R24,R25,R30, R31,R37,R38	RES, 10 Ω, 5%, 1/10 W, Thick Film, 0603	ERJ-3GEYJ100V	Panasonic
31	4	R26,R32,R39, R49	RES, 10 kΩ, 5%, 1/10 W, Thick Film, 0603	ERJ-3GEYJ103V	Panasonic
32	3	R27,R33,R40	RES, 44.2 kΩ, 1%, 1/8 W, Thick Film, 0805	ERJ-6ENF4422V	Panasonic
33	3	R28,R34,R41	RES, 44.2 kΩ, 1%, 1/16 W, Thick Film, 0603	ERJ-3EKF4422V	Panasonic
34	3	R29,R35,R42	RES, 0.22 R, 5%, 1/4 W, Thick Film, 1206	ERJ8RQJR22U	Panasonic
35	1	R36	RES, 4.75 k, 1%, 1/8 W, Thick Film, 0805	ERJ-6ENF4751V	Panasonic
36	3	R43,R45,R47	RES, 150 Ω, 5%, 1/10 W, Thick Film, 0603	ERJ-3GEYJ151V	Panasonic
37	3	R44,R46,R48	RES, 560 Ω, 5%, 1/10 W, Thick Film, 0603	ERJ-3GEYJ561V	Panasonic
38	1	R50	RES, 0 Ω, 5%, 1/10 W, Thick Film, 0603	ERJ-3GEY0R00V	Panasonic
39	1	RT1	NTC Thermistor, 100 kΩ, 5%, 0603	ERT-J1VS104JA	Panasonic
40	3	U1,U2,U3	BridgeSwitch, BLDC Motor Current 5.5 A (DC)	BRD1265C	Power Integrations
41	1	U4	LinkSwitch-TN2, SO-8C	LNK3204D	Power Integrations
42	1	U5	IC, REG, LDO, 5.0 V, 0.15 A, 28 Vin max, SOT23-5, SC-74A, SOT-753	MCP1804T-5002I/OT	MicroChip
43	1	U6	IC, GP OPamp, Quad, R2R, 14-TSSOP	AD8648ARUZ-REEL	Analog Devices



7 Performance Data

This section presents waveform plots and performance data of the BridgeSwitch inverter. The high voltage (VBUS) level is 340 VDC unless stated otherwise. Light load measurements describe the inverter operating with no mechanical brake load applied to the motor. Full load operation describes the inverter operating at 300 W output power (refer to the Appendix for details on the method used to measure output power in a three-phase inverter). All measurements were performed at 12 kHz PWM frequency, 28°C average ambient temperature, and using three-phase modulation field-oriented control.

7.1 Start-Up Operation

7.1.1 BPL and BPH Start-Up Waveforms

The waveforms below show the low-side and high-side BYPASS pin voltages of device U3 (Phase W) after VBUS = 340 VDC bus turns on. The start-up power up sequence follows the recommended start-up sequence described in section 8.1. The VBUS turn-on slew rate is set at 5 V / ms.

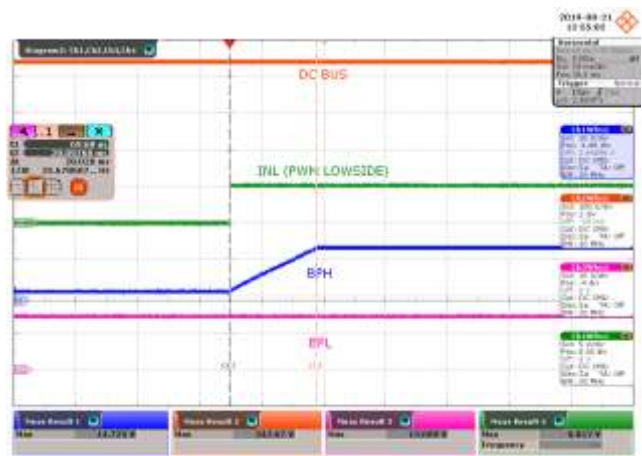
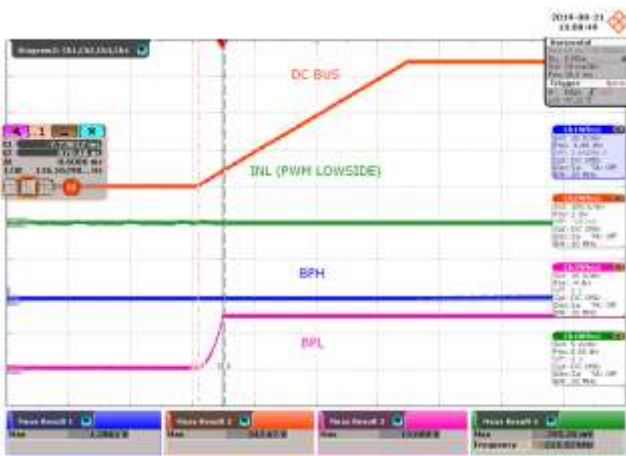

Figure 12 – BPL/BPH Start-up at Light Load, INL = 0 V.

CH2: V_{BUS} , 100 V / div.
 CH4: V_{INL} , 5 V / div.
 CH1: V_{BPH} , 10 V / div.
 CH3: V_{BPL} , 10 V / div.
 Time Scale: 20 ms / div.
 BPL Rise Time = 8.6 ms.

Figure 13 – BPL/BPH Start-up at Light Load, INL = 5 V.

CH2: V_{BUS} , 100 V / div.
 CH4: V_{INL} , 5 V / div.
 CH1: V_{BPH} , 10 V / div.
 CH3: V_{BPL} , 10 V / div.
 Time Scale: 20 ms / div.
 BPH Rise Time = 28 ms.

7.1.2 Motor Start-Up Waveforms

The waveforms below demonstrate the motor start-up of the BridgeSwitch FOC inverter at light load up to 100 W loading condition. The VBUS is set at 340 VDC and the motor maximum speed is set at 5000 RPM.

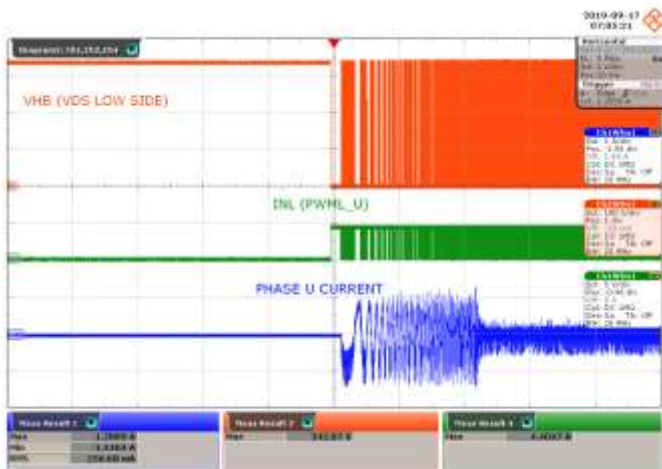

Figure 14 – Motor Start-up at Light Load.

CH2: V_{HB} , 100 V / div.

CH4: V_{INL} , 5 V / div.

CH1: $I_{PHASE_CURRENT}$, 1 A / div.

Time Scale: 2 s / div.

Maximum Phase Peak Current = 1.44 A_{PK}.

Maximum VHB Peak Voltage = 342.67 V_{PK}.

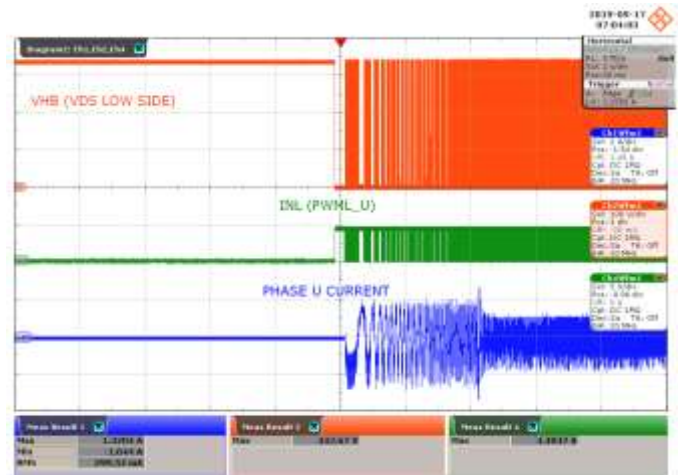

Figure 15 – Motor Start-up at 100 W Load.

CH2: V_{HB} , 100 V / div.

CH4: V_{INL} , 5 V / div.

CH1: $I_{PHASE_CURRENT}$, 1 A / div.

Time Scale: 2 s / div.

Maximum Phase Peak Current = 1.64 A_{PK}.

Maximum VHB Peak Voltage = 342.67 V_{PK}.

7.2 Steady-State Operation

7.2.1 Phase Voltages (Drain-to-Source) During Steady-State

The waveforms below show the phase voltages of the BridgeSwitch (low-side drain-to-source voltage) three-phase inverter using field-oriented control. The maximum peak voltage was measured from light to full load (inverter load) during steady-state operation. The VBUS is 340 VDC and the motor speed is 5000 RPM.

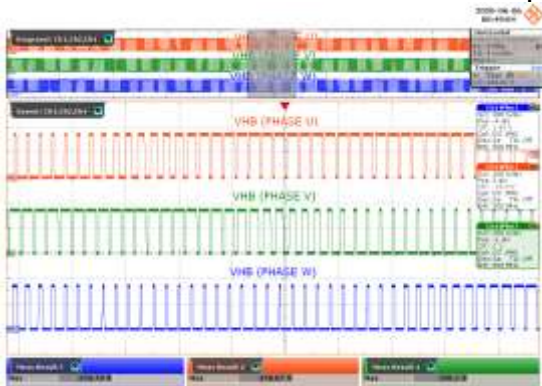

Figure 16 – Drain-to-Source Voltage at Light Load.

CH2: V_{HB_PHASEU} , 200 V / div.

CH4: V_{HB_PHASEV} , 200 V / div.

CH1: V_{HB_PHASEW} , 200 V / div.

Time Scale: 4 ms / div.

Maximum Peak Voltage (U) = 358.87 V_{PK} .

Maximum Peak Voltage (V) = 358.10 V_{PK} .

Maximum Peak Voltage (W) = 358.79 V_{PK} .

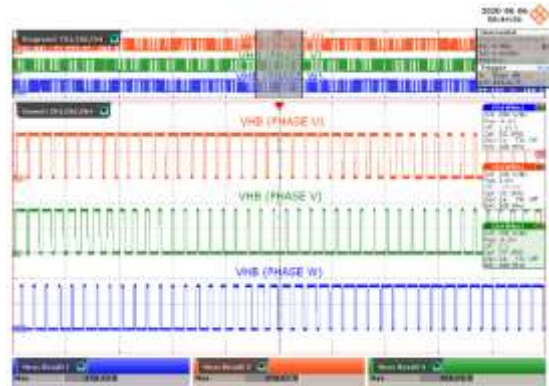

Figure 17 – Drain-to-Source Voltage at 100 W Load.

CH2: V_{HB_PHASEU} , 200 V / div.

CH4: V_{HB_PHASEV} , 200 V / div.

CH1: V_{HB_PHASEW} , 200 V / div.

Time Scale: 4 ms / div.

Maximum Peak Voltage (U) = 358.87 V_{PK} .

Maximum Peak Voltage (V) = 366.01 V_{PK} .

Maximum Peak Voltage (W) = 358.79 V_{PK} .

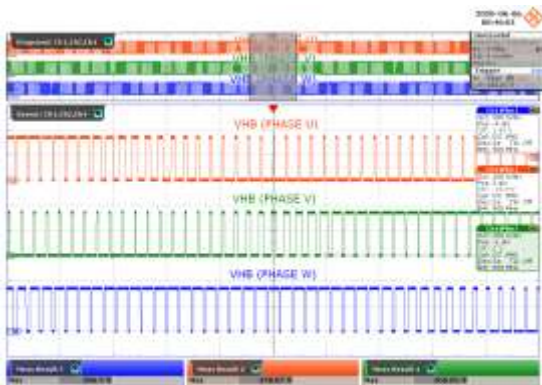

Figure 18 – Drain-to-Source Voltage at 200 W Load.

CH2: V_{HB_PHASEU} , 200 V / div.

CH4: V_{HB_PHASEV} , 200 V / div.

CH1: V_{HB_PHASEW} , 200 V / div.

Time Scale: 4 ms / div.

Maximum Peak Voltage (U) = 358.87 V_{PK} .

Maximum Peak Voltage (V) = 366.01 V_{PK} .

Maximum Peak Voltage (W) = 366.70 V_{PK} .

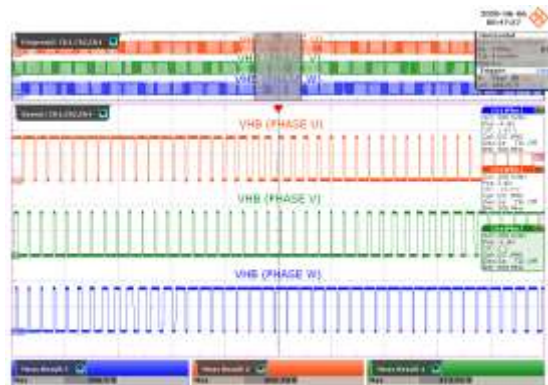

Figure 19 – Drain-to-Source Voltage at 300 W Load.

CH2: V_{HB_PHASEU} , 200 V / div.

CH4: V_{HB_PHASEV} , 200 V / div.

CH1: V_{HB_PHASEW} , 200 V / div.

Time Scale: 4 ms / div.

Maximum Peak Voltage (U) = 366.78 V_{PK} .

Maximum Peak Voltage (V) = 373.91 V_{PK} .

Maximum Peak Voltage (W) = 366.70 V_{PK} .

7.2.2 High-Side Drain-to-Source Voltage Slew Rate

The waveforms below show the voltage slew rate at TURN ON and TURN OFF transitions of the high-side BridgeSwitch FREDFET. The measurements were taken at 340 VDC, 5000 RPM, 200 W and 300 W loading condition.

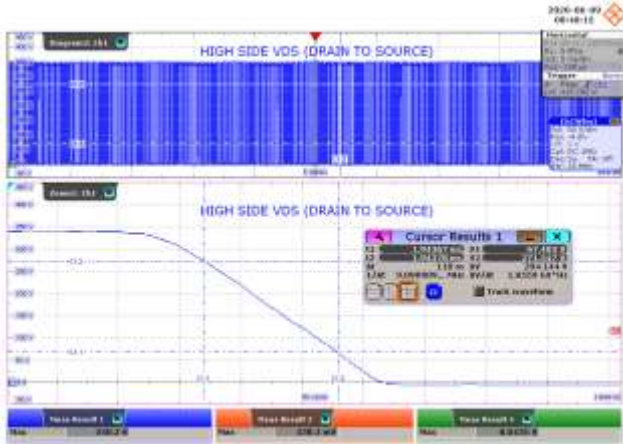

Figure 20 –TURN ON Slew Rate, 200 W Load.
 CH1: $V_{DS_HIGH_SIDE}$, 50 V / div.
 Time Scale: 5 ms / div.
 Time Scale (Zoomed Area): 50 ns / div.
 Measured Slew Rate = 1.86 V / ns.

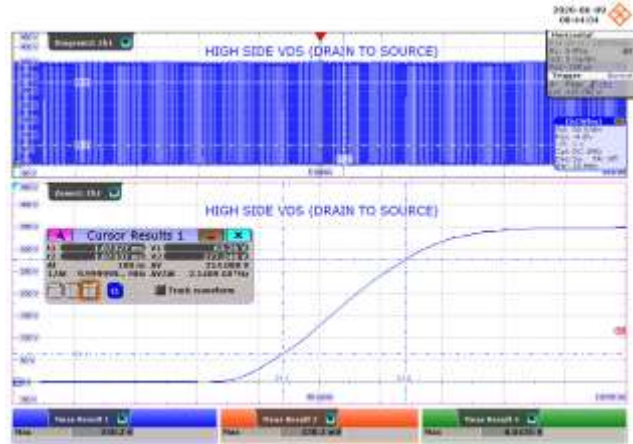

Figure 21 – TURN OFF Slew Rate, 200 W Load.
 CH1: $V_{DS_HIGH_SIDE}$, 50 V / div.
 Time Scale: 5 ms / div.
 Time Scale (Zoomed Area): 50 ns / div.
 Measured Slew Rate = 2.14 V / ns.

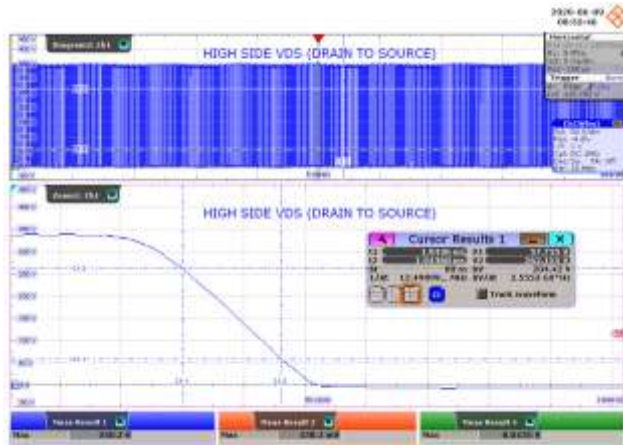

Figure 22 –TURN ON Slew Rate, 300 W Load.
 CH1: $V_{DS_HIGH_SIDE}$, 50 V / div.
 Time Scale: 5 ms / div.
 Time Scale (Zoomed Area): 50 ns / div.
 Measured Slew Rate = 2.56 V / ns.

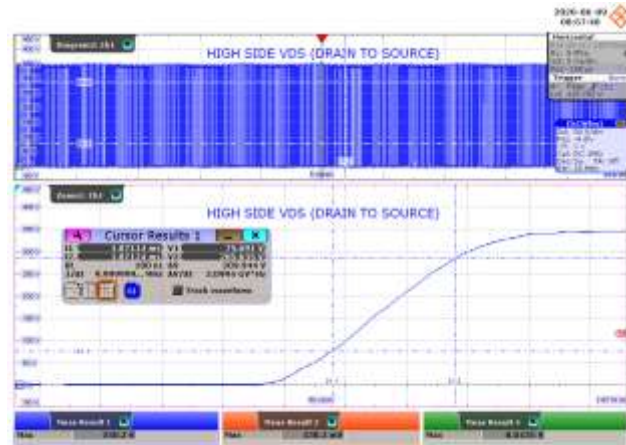

Figure 23 – TURN OFF Slew Rate, 300 W Load.
 CH1: $V_{DS_HIGH_SIDE}$, 50 V / div.
 Time Scale: 5 ms / div.
 Time Scale (Zoomed Area): 50 ns / div.
 Measured Slew Rate = 2.10 V / ns.

7.2.3 Phase Currents During Steady-State

The waveforms below show the phase currents of the BridgeSwitch three-phase inverter using field-oriented method of control (FOC). The maximum peak current was measured from light load to 300 W loading condition during steady-state operation.

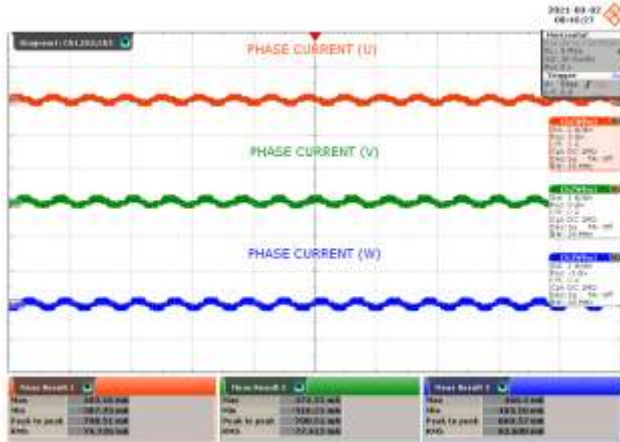

Figure 24 – Phase Current at Light Load.

CH1: I_{PHASEU} , 2 A / div.
 CH2: I_{PHASEV} , 2 A / div.
 CH3: I_{PHASEW} , 2 A / div.
 Time Scale: 10 ms / div.
 RMS Current (U) = 75 mA_{RMS}.
 RMS Current (V) = 77 mA_{RMS}.
 RMS Current (W) = 84 mA_{RMS}.

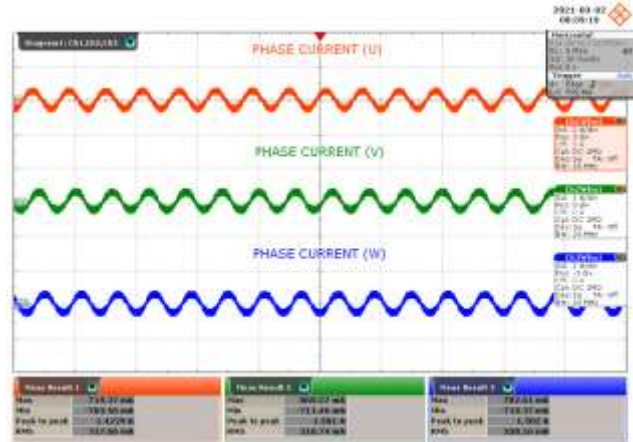

Figure 25 – Phase Current at 100 W Load.

CH1: I_{PHASEU} , 2 A / div.
 CH2: I_{PHASEV} , 2 A / div.
 CH3: I_{PHASEW} , 2 A / div.
 Time Scale: 10 ms / div.
 RMS Current (U) = 318 mA_{RMS}.
 RMS Current (V) = 319 mA_{RMS}.
 RMS Current (W) = 330 mA_{RMS}.

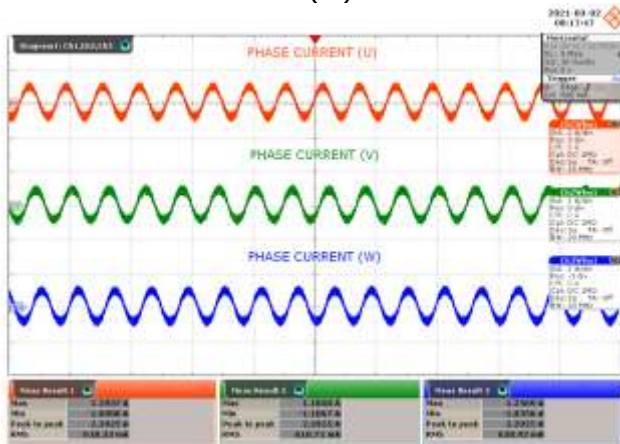

Figure 26 – Phase Current at 200 W Load.

CH1: I_{PHASEU} , 2 A / div.
 CH2: I_{PHASEV} , 2 A / div.
 CH3: I_{PHASEW} , 2 A / div.
 Time Scale: 10 ms / div.
 RMS Current (U) = 618 mA_{RMS}.
 RMS Current (V) = 619 mA_{RMS}.
 RMS Current (W) = 631 mA_{RMS}.

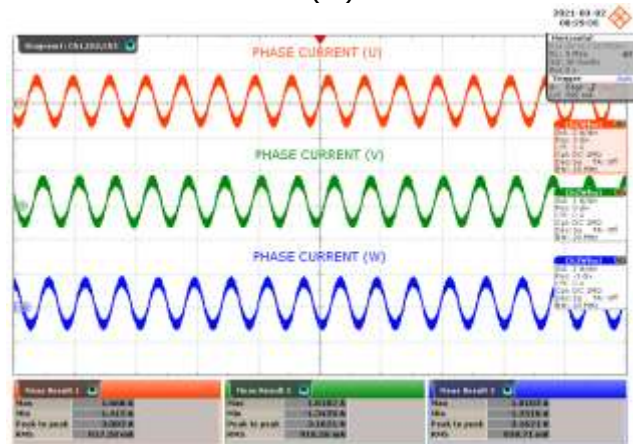

Figure 27 – Phase Current at 300 W Load.

CH1: I_{PHASEU} , 2 A / div.
 CH2: I_{PHASEV} , 2 A / div.
 CH3: I_{PHASEW} , 2 A / div.
 Time Scale: 10 ms / div.
 RMS Current (U) = 917 mA_{RMS}.
 RMS Current (V) = 917 mA_{RMS}.
 RMS Current (W) = 940 mA_{RMS}.

7.2.4 INL and /INH Signals

The waveforms below show the low-side (INL) and high-side (/INH) input PWM signals during light load to full load condition at steady-state operation. The PWM frequency is set at 12 kHz with a constant motor speed of 5000 RPM.

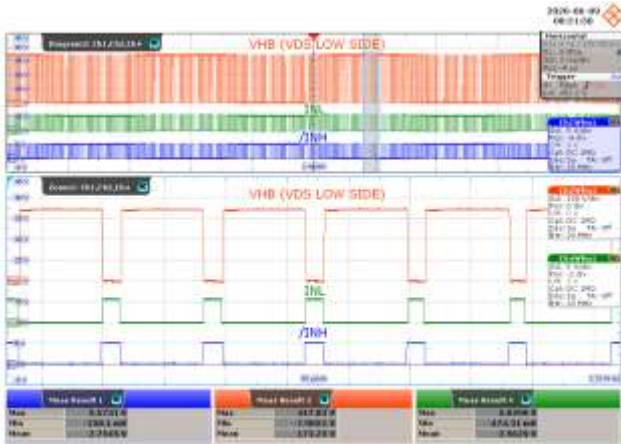

Figure 28 – INL and /INH Signal at Light Load.
 CH2: V_{HB_PHASEW} , 100 V / div.
 CH4: V_{INL} , 5 V / div.
 CH1: V_{INH} , 5 V / div.
 Time Scale: 2 ms / div.
 Time Scale (Zoomed Area): 50 μ s / div.

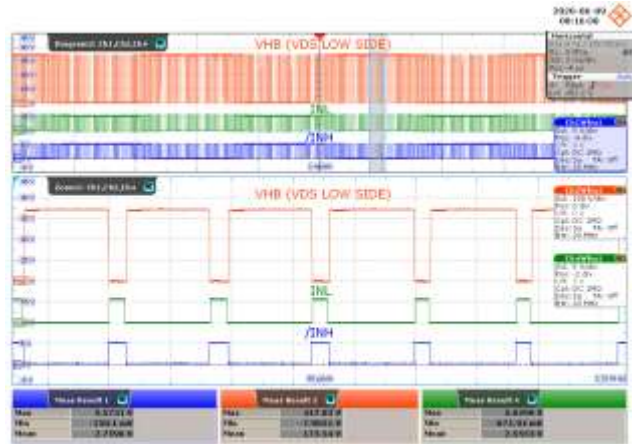

Figure 29 – INL and /INH Signal at 100 W Load.
 CH2: V_{HB_PHASEW} , 100 V / div.
 CH4: V_{INL} , 5 V / div.
 CH1: V_{INH} , 5 V / div.
 Time Scale: 2 ms / div.
 Time Scale (Zoomed Area): 50 μ s / div.

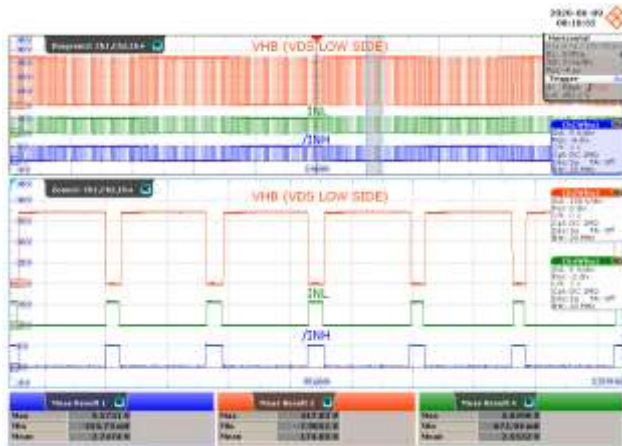

Figure 30 – INL and /INH Signal at 200 W Load.
 CH2: V_{HB_PHASEW} , 100 V / div.
 CH4: V_{INL} , 5 V / div.
 CH1: V_{INH} , 5 V / div.
 Time Scale: 2 ms / div.
 Time Scale (Zoomed Area): 50 μ s / div.

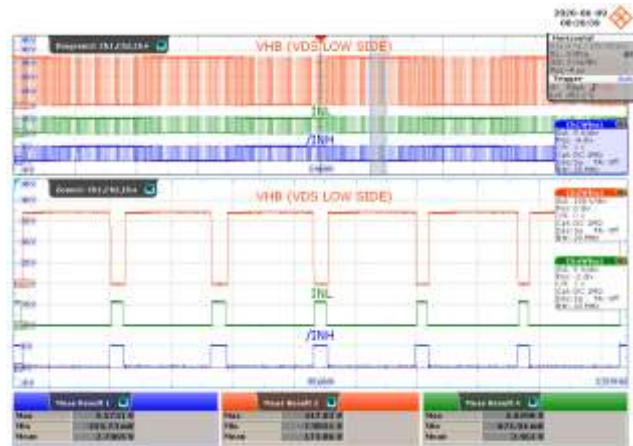

Figure 31 – INL and /INH Signal at 300 W Load.
 CH2: V_{HB_PHASEW} , 100 V / div.
 CH4: V_{INL} , 5 V / div.
 CH1: V_{INH} , 5 V / div.
 Time Scale: 2 ms / div.
 Time Scale (Zoomed Area): 50 μ s / div.

7.2.5 **BPL and BPH during Steady-State**

The waveforms below show the BPL and BPH (low-side and high-side self-supply bias level respectively) from light load to full load condition during steady-state operation.

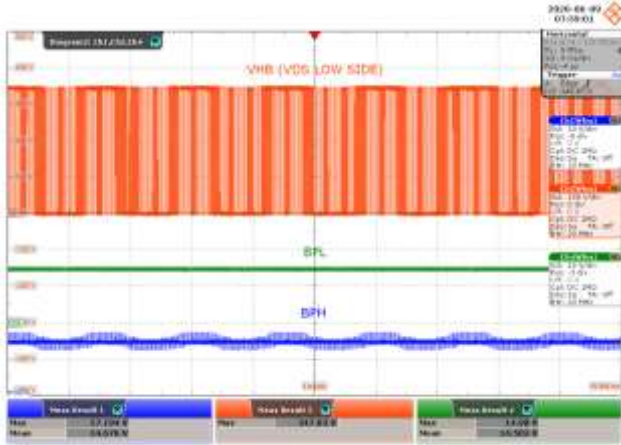

Figure 32 – BPL and BPH Signal at Light Load.
 CH2: V_{HB_PHASEW} , 100 V / div.
 CH4: V_{BPL} , 10 V / div.
 CH1: V_{BPH} , 10 V / div.
 Time Scale: 4 ms / div.
 BPL Average Voltage = 14.50 V.
 BPH Average Voltage = 14.67 V.

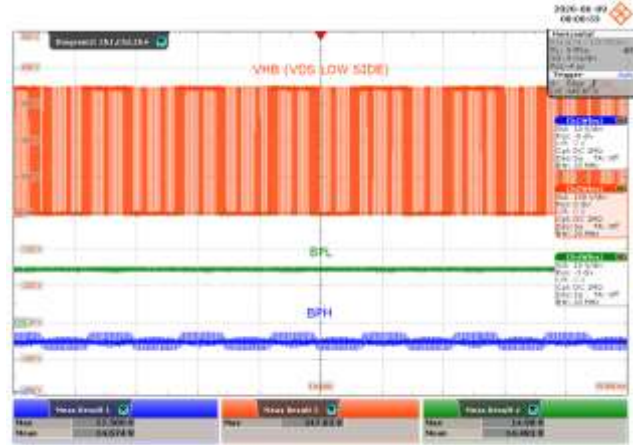

Figure 33 – BPL and BPH Signal at 100 W Load.
 CH2: V_{HB_PHASEW} , 100 V / div.
 CH4: V_{BPL} , 10 V / div.
 CH1: V_{BPH} , 10 V / div.
 Time Scale: 4 ms / div.
 BPL Average Voltage = 14.48 V.
 BPH Average Voltage = 14.67 V.

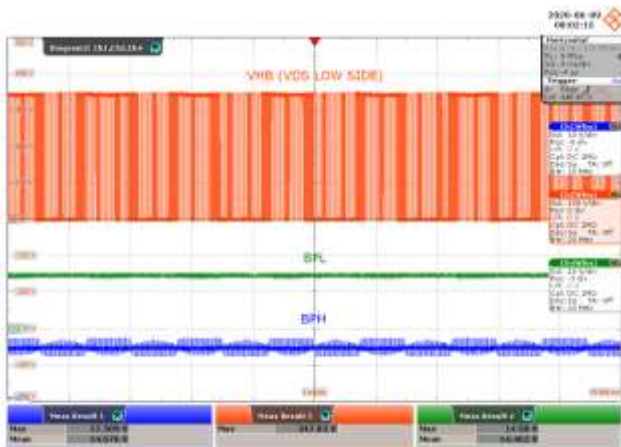

Figure 34 – BPL and BPH Signal at 200 W Load.
 CH2: V_{HB_PHASEW} , 100 V / div.
 CH4: V_{BPL} , 10 V / div.
 CH1: V_{BPH} , 10 V / div.
 Time Scale: 4 ms / div.
 BPL Average Voltage = 14.46 V.
 BPH Average Voltage = 14.67 V.

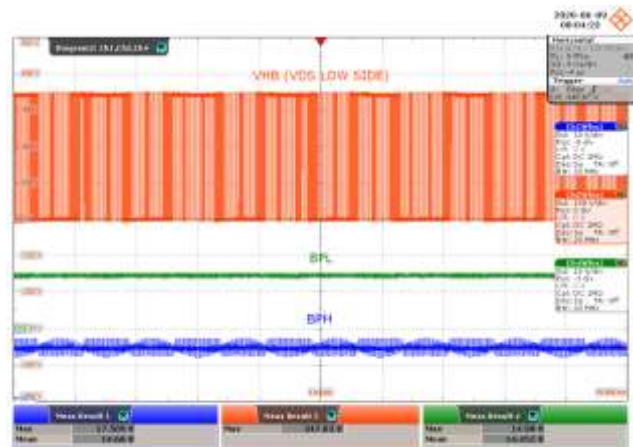

Figure 35 – BPL and BPH Signal at 300 W Load.
 CH2: V_{HB_PHASEW} , 100 V / div.
 CH4: V_{BPL} , 10 V / div.
 CH1: V_{BPH} , 10 V / div.
 Time Scale: 4 ms / div.
 BPL Average Voltage = 14.45 V.
 BPH Average Voltage = 14.66 V.

7.3 Thermal Performance

The thermal scans below depict on-board device thermal performance after 20 minutes each for 100 W, 200 W, and 300 W inverter output power running at a constant speed of 5000 RPM, 12 kHz PWM switching frequency, three-phase FOC modulation, BridgeSwitch device at self and external supply mode, with an average ambient temperature of 28 °C measured three inches above the inverter board. The auxiliary circuit, +5 V linear regulator, and input diode were disabled to reflect only the inverter temperature by depopulating components U4, U5, and D6. An external +5 VDC supply was provided between pins +5 V and GND for the microcontroller and current sense amplifier. An additional +17 VDC supply was used during external supply mode for the bypass pin supply. The inverter setup was enclosed in an acrylic case to minimize the effects of air flow on the thermal data.

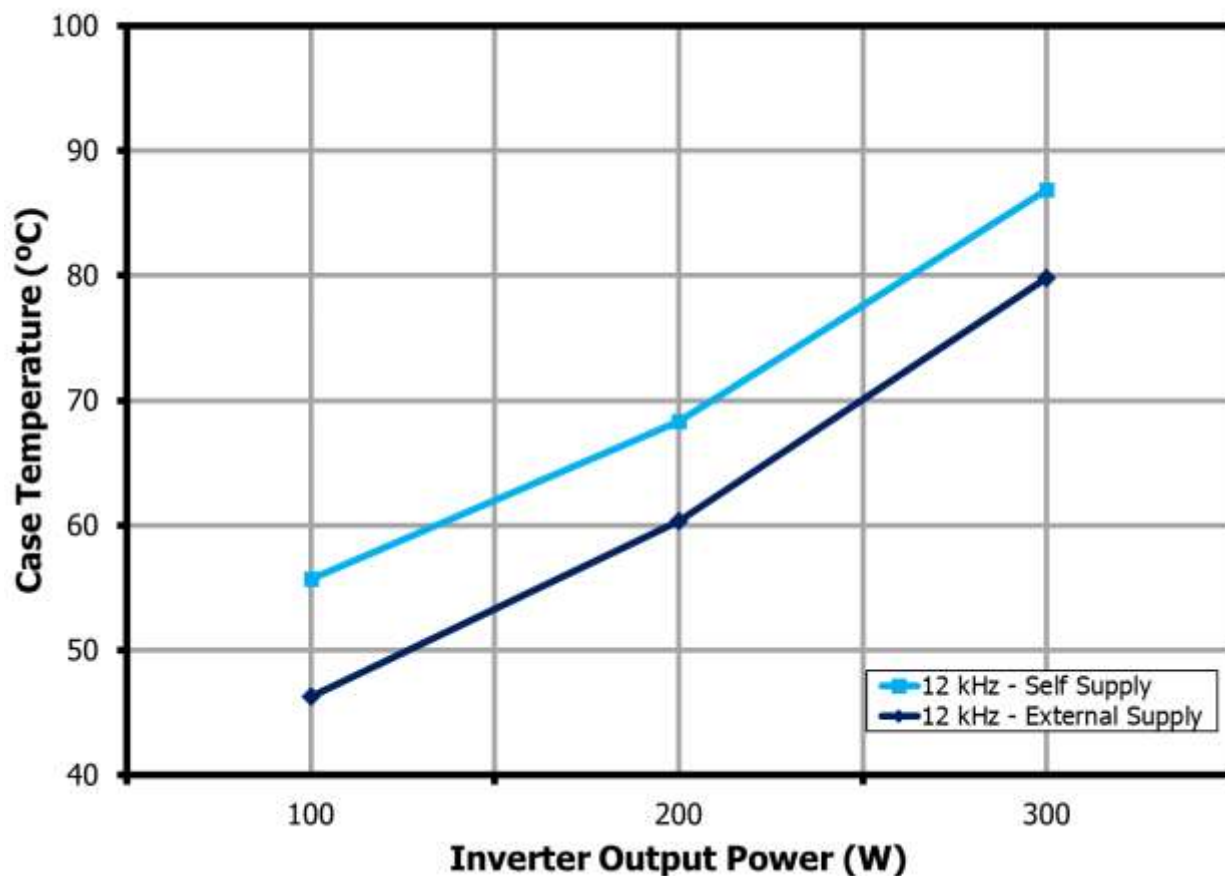

Figure 36 – Thermal Performance at Self and External Supply Mode.

7.3.1 100 W Loading Condition (315 mA Average Motor Phase Current)

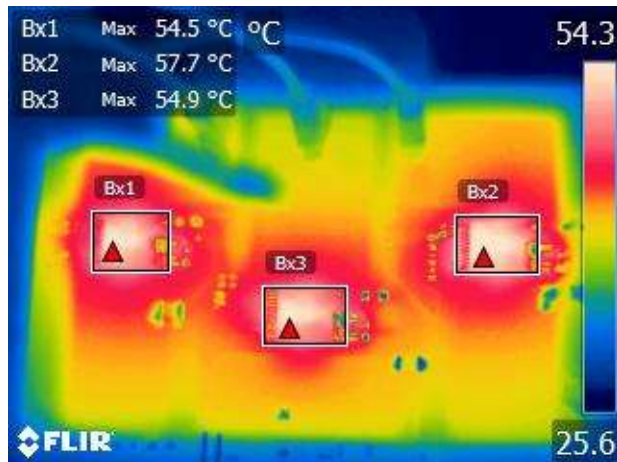

Figure 37 – BridgeSwitch Device Case Temperatures at 100 W Output Power (Self-Supply Mode).

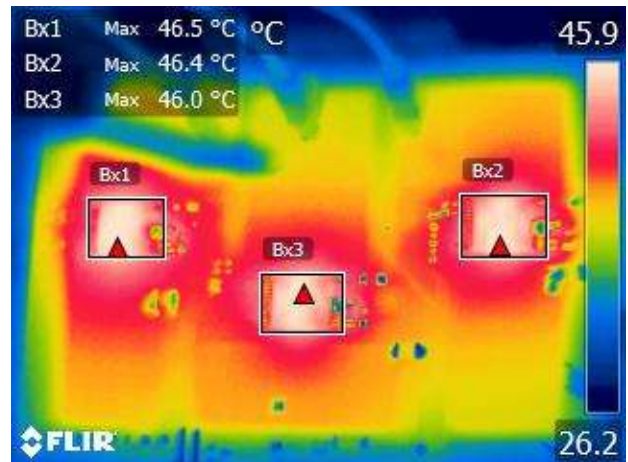

Figure 38 – BridgeSwitch Device Case Temperatures at 100 W Output Power (External Supply Mode).

7.3.2 200 W Loading Condition (620 mA Average Motor Phase Current)

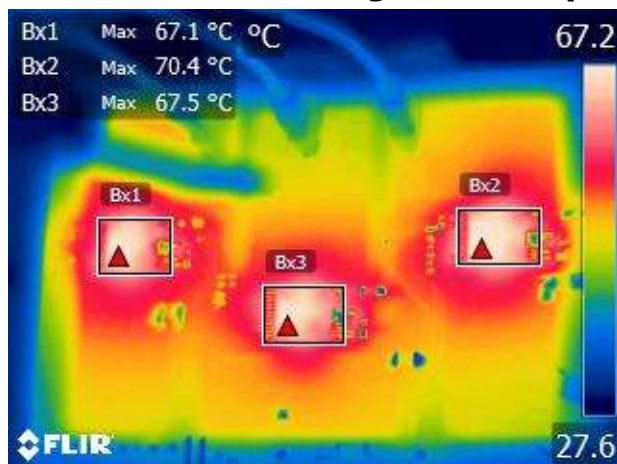

Figure 39 – BridgeSwitch Device Case Temperatures at 200 W Output Power (Self-Supply Mode).

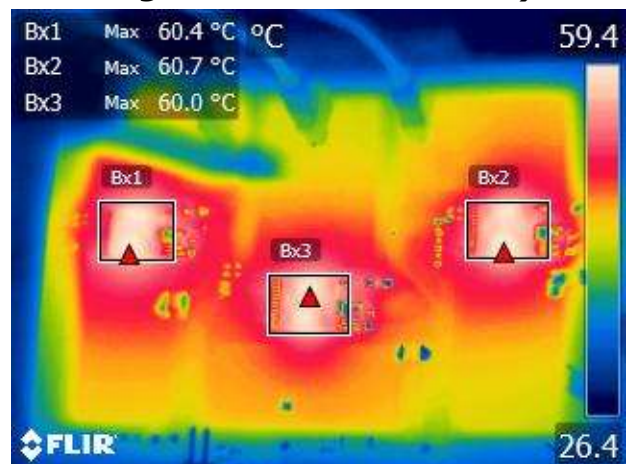

Figure 40 – BridgeSwitch Device Case Temperatures at 200 W Output Power (External Supply Mode).

7.3.3 300 W Loading Condition (915 mA Average Motor Phase Current)

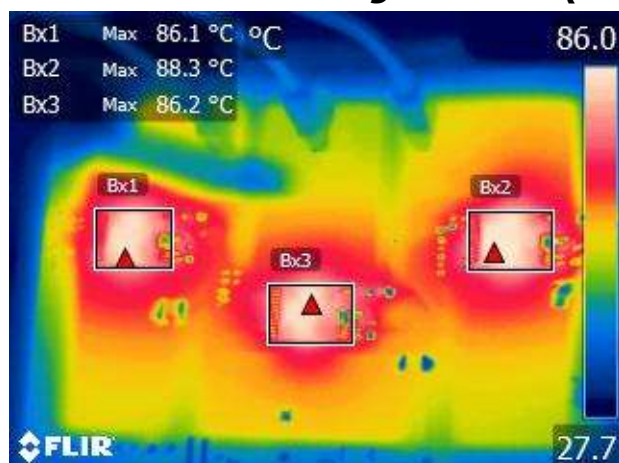

Figure 41 – BridgeSwitch Device Case Temperatures at 300 W Output Power (Self-Supply Mode).

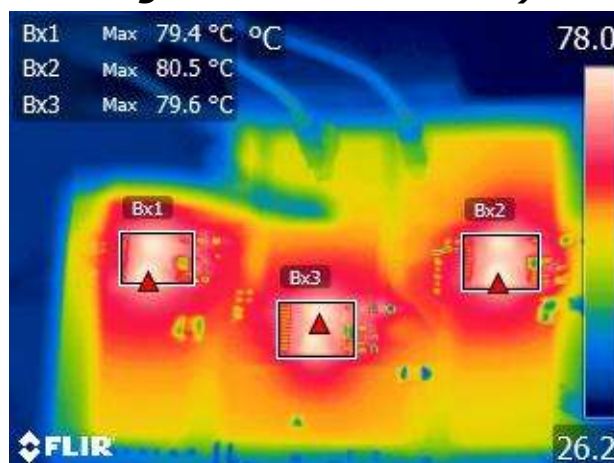

Figure 42 – BridgeSwitch Device Case Temperatures at 300 W Output Power (External Supply Mode).

7.3.4 Thermal Scan Summary Table

7.3.4.1 Self Supply Mode

Phase	Device	Inverter Output Power		
		100 W	200 W	300 W
U	U1	54.5	67.1	86.1
V	U2	57.7	70.4	88.3
W	U3	54.9	67.5	86.2
	Ave. Case Temp	55.7	68.3	86.9

7.3.4.2 External Supply Mode

Phase	Device	Inverter Output Power		
		100 W	200 W	300 W
U	U1	46.5	60.4	79.4
V	U2	46.4	60.7	80.5
W	U3	46.0	60.0	79.6
	Ave. Case Temp	46.3	60.4	79.8

7.4 **No-Load Input Power Consumption**

The graph below illustrates the BridgeSwitch three-phase inverter no-load input power measured at different input voltages. The voltage was measured directly at the positive input DC BUS of the inverter. The input diode, auxiliary circuit, +5 V linear regulator, and current sense amplifier were disabled by depopulating components D6, U4, U5, and U6.

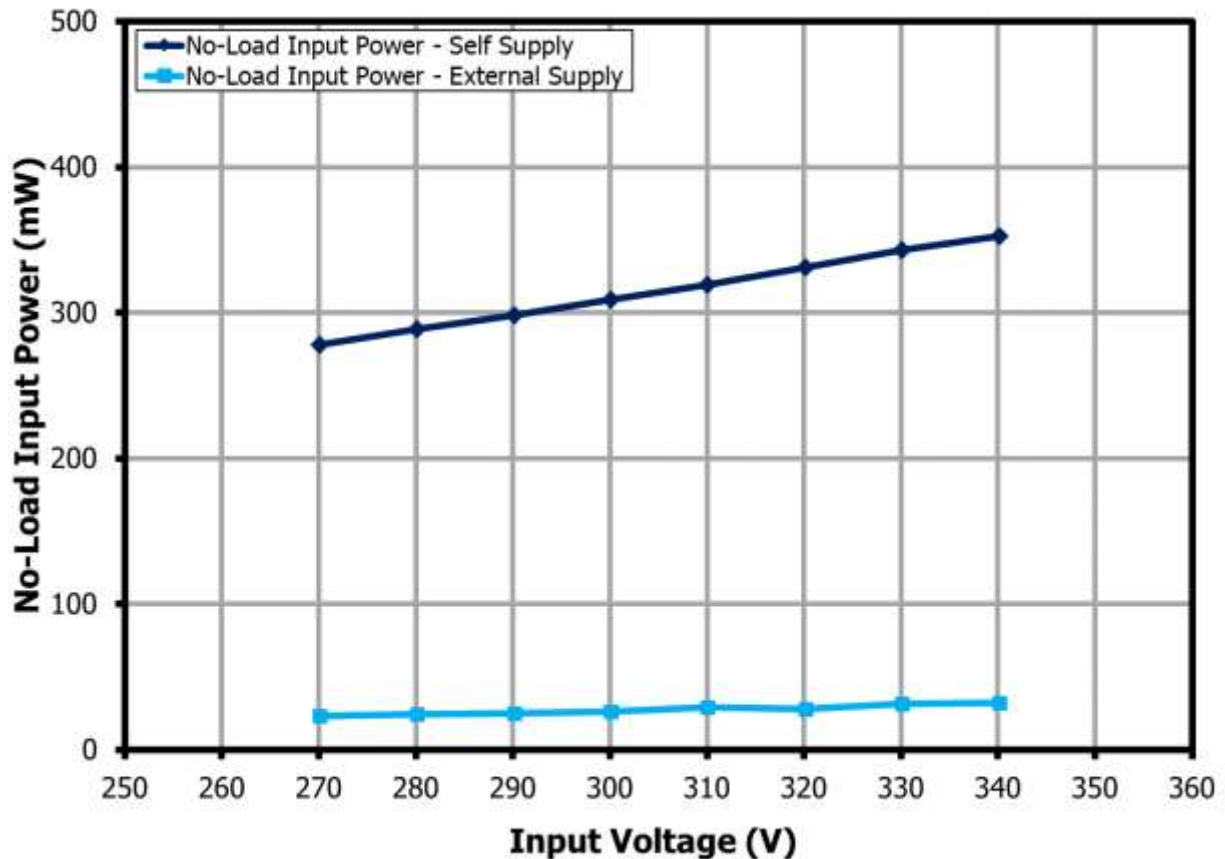

Figure 43 – No-Load Input Power.

7.5 Efficiency

The graph and table below displays the BridgeSwitch inverter efficiency at 340 VDC input, 12 kHz PWM switching frequency, a constant motor speed of 5000 RPM, three-phase FOC modulation, BridgeSwitch devices at self and external supply mode, and at an average ambient temperature of 28°C. The auxiliary circuit, 5 V linear regulator, and current sense amplifier were disabled for efficiency data accuracy. This was accomplished by measuring the input voltage directly at the positive input DC BUS of the inverter, and depopulating components D6, U4, and U5. An external +5 VDC supply was provided between pins +5 V and GND for the microcontroller and current sense amplifier. An additional +17 VDC supply was used during external supply mode for the bypass pin supply.

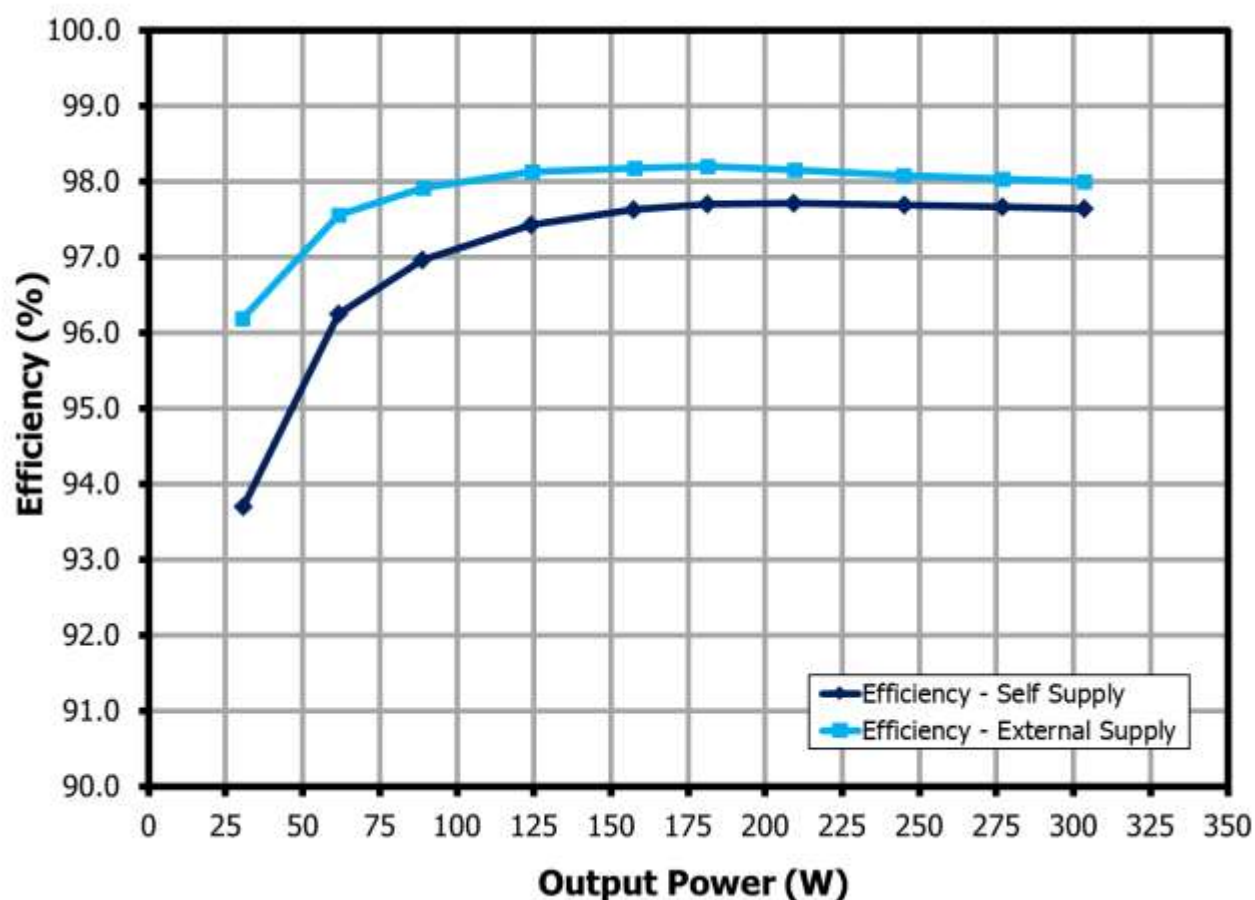

Figure 44 – Inverter Efficiency Graph.

7.5.1 **Efficiency Table at Self Supply Mode**

DC Input Voltage (V _{IN})	Input DC Current (mA)	Input Power (W)	I _{RMSU} (mA)	I _{RMSV} (mA)	I _{RMSW} (mA)	Inverter Output Power (W)	Inverter Efficiency (%)
340	96	32.63	101	101	89	30.57	93.70
340	188	64.06	196	200	186	61.66	96.25
340	269	91.65	283	285	272	88.87	96.97
340	374	127.30	393	394	381	124.02	97.42
340	473	160.99	490	496	483	157.18	97.63
340	545	185.46	565	569	556	181.20	97.70
340	630	214.26	648	653	641	209.35	97.71
340	737	250.78	756	760	748	244.98	97.69
340	834	283.67	849	855	844	277.04	97.66
340	914	310.89	917	919	907	303.55	97.64

Table 2 – Efficiency Table (Self-Supply Mode).7.5.2 **Efficiency Table at External Supply Mode**

DC Input Voltage (V _{IN})	Input DC Current (mA)	Input Power (W)	I _{RMSU} (mA)	I _{RMSV} (mA)	I _{RMSW} (mA)	Inverter Output Power (W)	Inverter Efficiency (%)
340	93	31.59	100	101	89	30.39	96.19
340	186	63.30	195	200	186	61.75	97.56
340	268	91.07	284	286	273	89.17	97.91
340	373	126.82	396	395	382	124.44	98.12
340	471	160.43	490	496	483	157.51	98.18
340	543	184.69	565	568	556	181.36	98.20
340	628	213.59	648	653	641	209.65	98.16
340	734	249.75	755	759	747	244.96	98.08
340	830	282.38	847	852	841	276.81	98.03
340	911	309.78	914	916	904	303.56	97.99

Table 3 – Efficiency Table (External Supply Mode).

7.6 Device and System Level Protection / Monitoring

7.6.1 Overcurrent Protection (OCP)

The waveforms below depict the current limit triggering of the BridgeSwitch device. For this test, the current set resistors R_{XL} and R_{XH} were set to 44.2 k Ω resulting in a current limit of approximately 3 A.

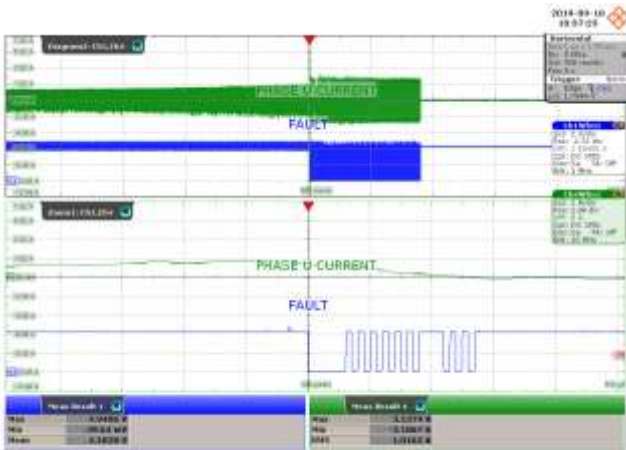

Figure 45 – OCP at $R_{XL}/R_{XH} = 44.2 \text{ k}\Omega$, $I_{LIM} = 3 \text{ A}$.
 CH4: I_{PHASE} , 2 A / div.
 CH1: V_{FAULT} , 2 V / div.
 Time Scale: 500 ms / div.
 Time Scale (Zoomed Area): 100 μs / div.
 FAULT Flag Reading = 0000010.

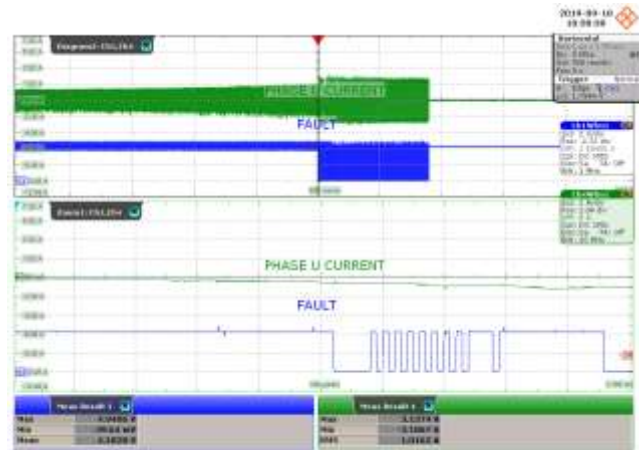

Figure 46 – OCP Fault Clear at $R_{XL}/R_{XH} = 44.2 \text{ k}\Omega$.
 CH4: I_{PHASE} , 2 A / div.
 CH1: V_{FAULT} , 2 V / div.
 Time Scale: 500 ms / div.
 Time Scale (Zoomed Area): 100 μs / div.
 FAULT Clear = 0000000.

7.6.2 Thermal Warning

The waveforms below depict the low-side FREDFET over-temperature warning. A localized external heat source was applied to the device to force temperature rise.

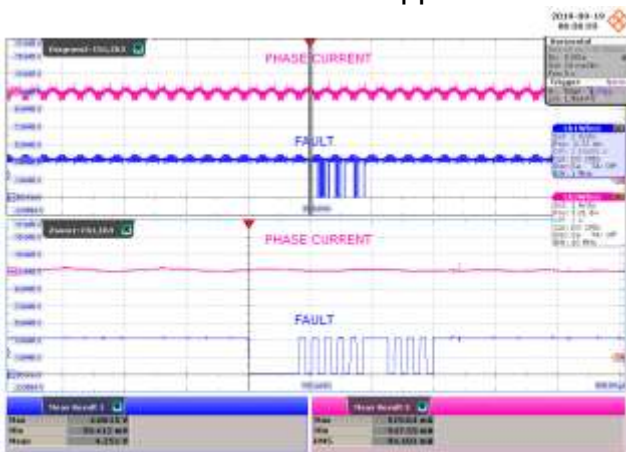

Figure 47 – Thermal Warning at Light Load.
 CH3: I_{PHASE} , 1 A / div.
 CH1: V_{FAULT} , 2 V / div.
 Time Scale: 20 ms / div.
 Time Scale (Zoomed Area): 100 μ s / div.
 FAULT Flag/Reading = 0000100.

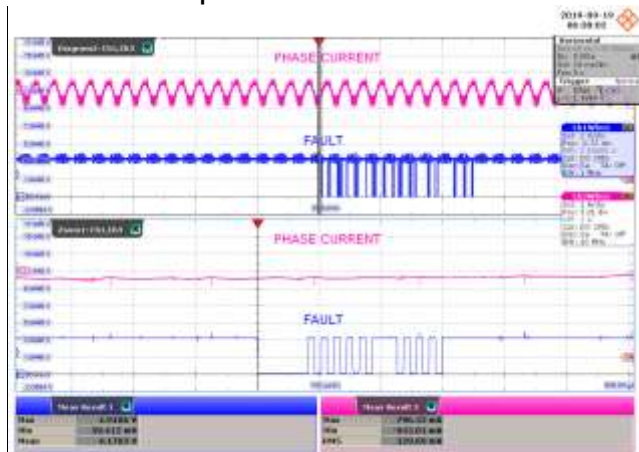

Figure 48 – Thermal Warning at 100 W.
 CH3: I_{PHASE} , 1 A / div.
 CH1: V_{FAULT} , 2 V / div.
 Time Scale: 20 ms / div.
 Time Scale (Zoomed Area): 100 μ s / div.
 FAULT Flag/Reading = 0000100.

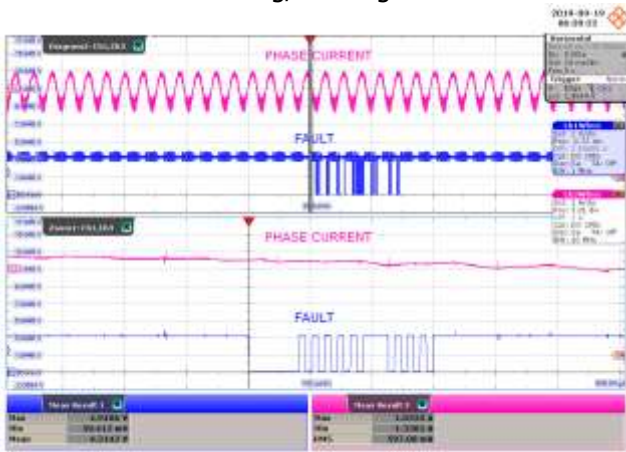

Figure 49 – Thermal Warning at 200 W.
 CH3: I_{PHASE} , 1 A / div.
 CH1: V_{FAULT} , 2 V / div.
 Time Scale: 20 ms / div.
 Time Scale (Zoomed Area): 100 μ s / div.
 FAULT Flag/Reading = 0000100.

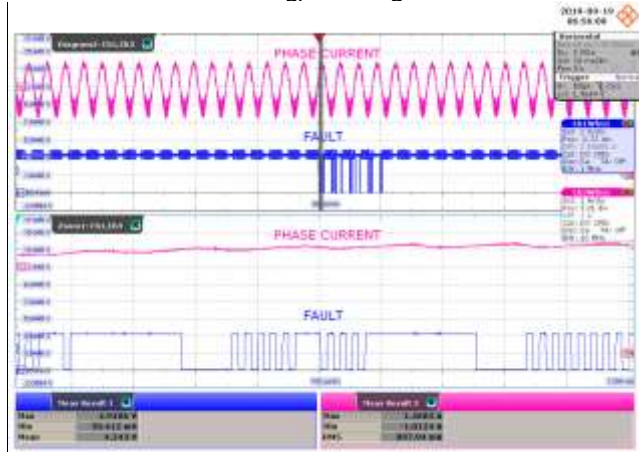

Figure 50 – Thermal Warning at 300 W.
 CH3: I_{PHASE} , 1 A / div.
 CH1: V_{FAULT} , 2 V / div.
 Time Scale: 20 ms / div.
 Time Scale (Zoomed Area): 100 μ s / div.
 FAULT Flag/Reading = 0000100.

7.6.3 Thermal Shutdown

The waveform below depicts the low-side FREDFET over-temperature shutdown. A localized external heat source was applied to a single BridgeSwitch device (U2) to force temperature rise while the inverter is running at 100W loading condition.

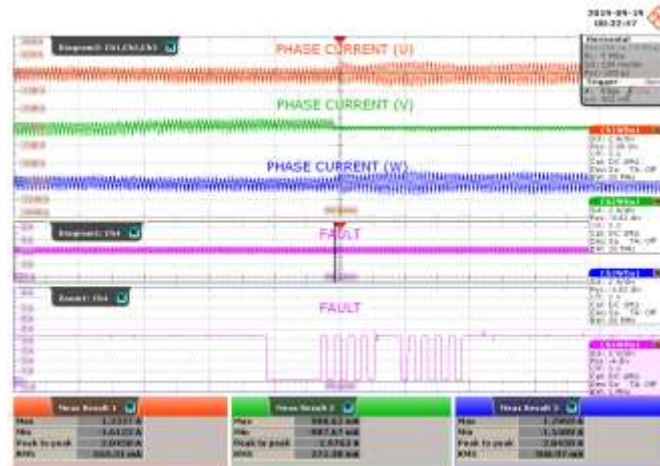

Figure 51 – Thermal Shutdown

CH1: I_{PHASEU} , 2 A / div.

CH2: I_{PHASEV} , 2 A / div.

CH3: I_{PHASEW} , 2 A / div.

CH4: V_{FAULT} , 1 V / div.

Time Scale: 100 ms / div.

Time Scale (Zoomed FAULT): 100 μ s / div.

FAULT Flag/Reading = 0001000.

7.6.4 Undervoltage (UV)

The test results below demonstrate the integrated bus UV monitoring function and status reporting through the communication bus (FAULT pin). Device U1 senses the bus voltage through resistors R21, R22, and R23.



Figure 52 – UVP, 5000 RPM, No-Load, 340 V to 220 V.

CH2: V_{BUS} , 100 V / div.

CH1: V_{FAULT} , 2 V / div.

Time Scale: 50 ms / div.

Time Scale (Zoomed Area): 100 μ s / div.

Voltage Slew Rate = 0.5 V / msec.

UV Level = 100%.

FAULT Flag Reading = 0100000.

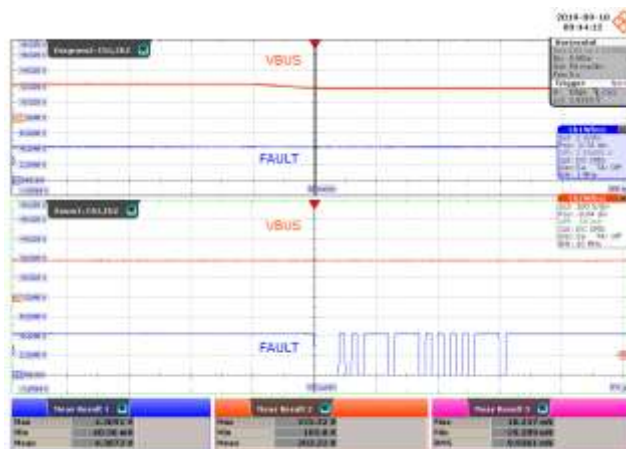

Figure 53 – UVP, 5000 RPM, No-Load, 220 V to 190 V.

CH2: V_{BUS} , 100 V / div.

CH1: V_{FAULT} , 2 V / div.

Time Scale: 50 ms / div.

Time Scale (Zoomed Area): 100 μ s / div.

Voltage Slew Rate = 0.5 V / msec.

UV Level = 85%.

FAULT Flag Reading = 0110000.

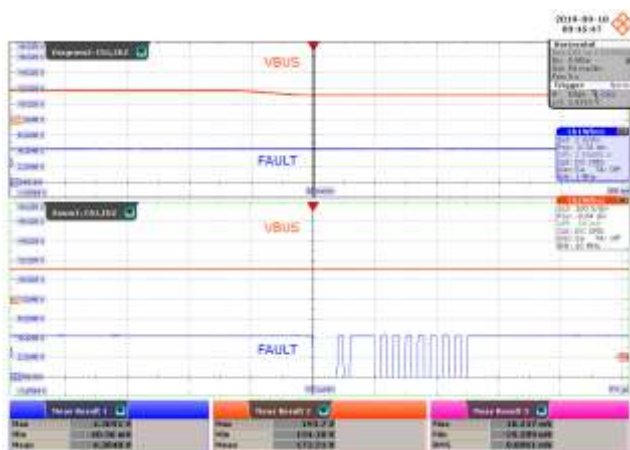

Figure 54 – UVP, 5000 RPM, No-Load, 190 V to 160 V.

CH2: V_{BUS} , 100 V / div.

CH1: V_{FAULT} , 2 V / div.

Time Scale: 50 ms / div.

Time Scale (Zoomed Area): 100 μ s / div.

Voltage Slew Rate = 0.5 V / msec.

UV Level = 70%.

FAULT Flag Reading = 1000000.

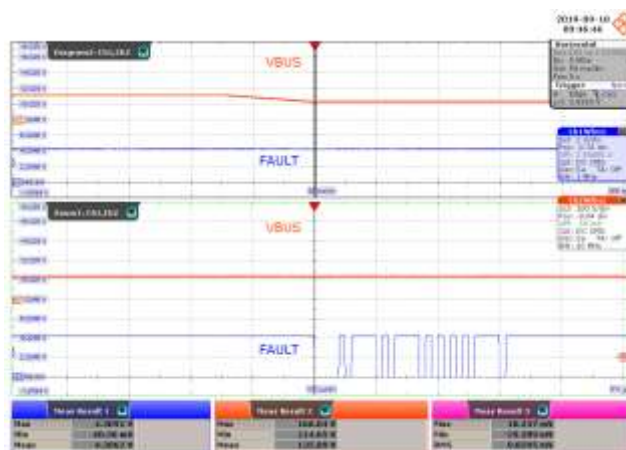

Figure 55 – UVP, 5000 RPM, No-Load, 160 V to 120 V.

CH2: V_{BUS} , 100 V / div.

CH1: V_{FAULT} , 2 V / div.

Time Scale: 50 ms / div.

Time Scale (Zoomed Area): 100 μ s / div.

Voltage Slew Rate = 0.5 V / msec.

UV Level = 55%.

FAULT Flag Reading = 1010000.

7.6.5 **Overvoltage (OV)**

The waveforms below illustrate the bus OV monitoring feature. The bus sensing resistance is set at 7 M Ω (total value of R21, R22, and R23) giving an overvoltage (OV) level threshold of 422 VDC. The BridgeSwitch device stops switching and reports the OV fault condition as soon as the bus voltage exceeds the OV threshold. Switching resumes after the bus voltage level drops below the OV detection threshold.

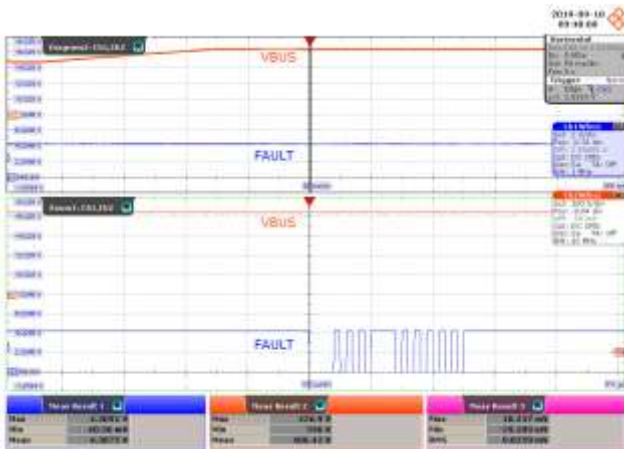

Figure 56 – OVP, 340 V to 425 V.

CH2: V_{BUS} , 100 V / div.

CH1: V_{FAULT} , 2 V / div.

Time Scale: 50 ms / div.

Time Scale (Zoomed Area): 100 μ s / div.

Voltage Slew Rate = 0.5 V / msec.

Measured OVP Level = 426.90 V.

FAULT Flag/Reading = 0010000.

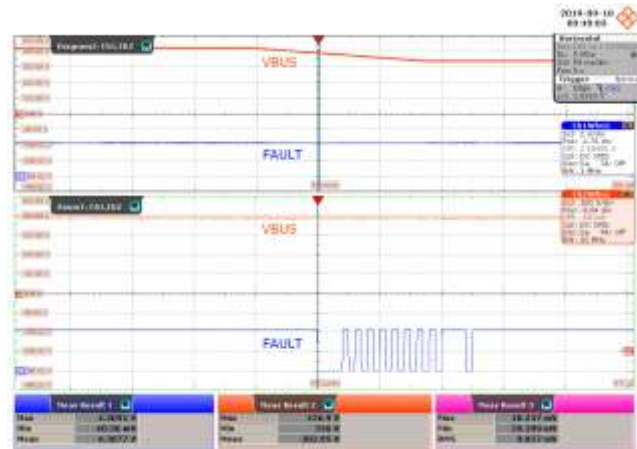

Figure 57 – OVP clear, 425 V to 340 V.

CH2: V_{BUS} , 100 V / div.

CH1: V_{FAULT} , 2 V / div.

Time Scale: 50 ms / div.

Time Scale (Zoomed Area): 100 μ s / div.

Voltage Slew Rate = 0.5 V / msec.

OV Fault Clear.

FAULT Flag/Reading = 0000000.

7.6.6 System Thermal Fault

The waveforms below show the system thermal warning flag of the BridgeSwitch device through an external thermistor RT1. The device checks the resistance connected to the SM pin every second for a period of 10 ms. The system temperature fault was simulated by applying a localized external heat to sense thermistor RT1 with the motor running at different loading conditions.

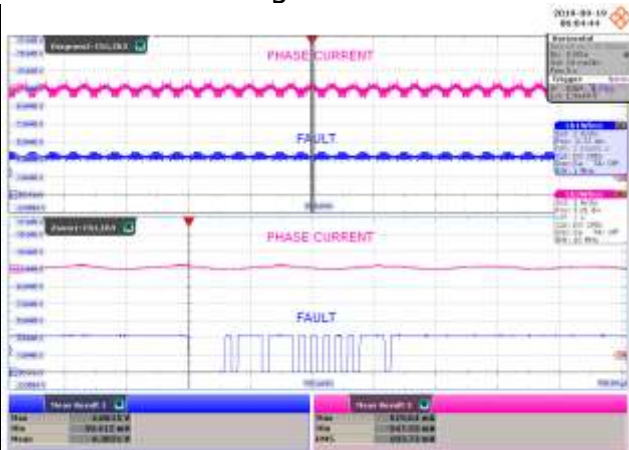

Figure 58 – System Thermal Fault, 5000 RPM, Light Load.

CH3: I_{PHASE} , 1 A / div.
 CH1: V_{FAULT} , 2 V / div.
 Time Scale: 20 ms / div.
 Time Scale (Zoomed Area): 100 μ s / div.
 FAULT Flag/Reading = 1100000.

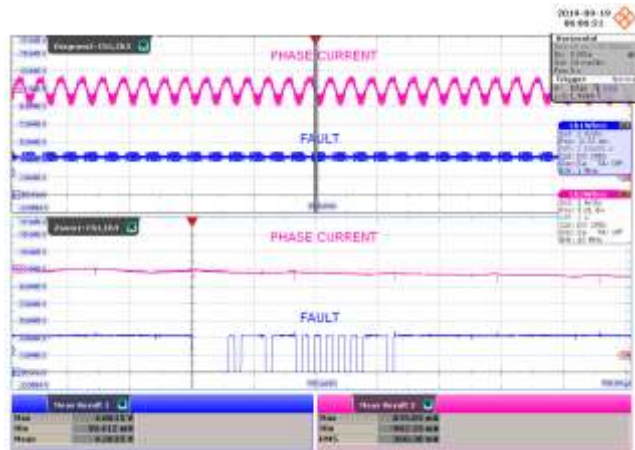

Figure 59 – System Thermal Fault, 5000 RPM, 100 W.

CH3: I_{PHASE} , 1 A / div.
 CH1: V_{FAULT} , 2 V / div.
 Time Scale: 20 ms / div.
 Time Scale (Zoomed Area): 100 μ s / div.
 FAULT Flag/Reading = 1100000.

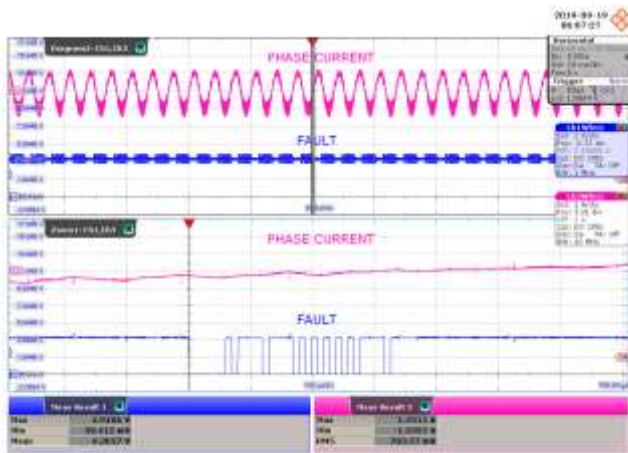

Figure 60 – System Thermal Fault, 5000 RPM, 200 W.

CH3: I_{PHASE} , 1 A / div.
 CH1: V_{FAULT} , 2 V / div.
 Time Scale: 20 ms / div.
 Time Scale (Zoomed Area): 100 μ s / div.
 FAULT Flag/Reading = 1100000.

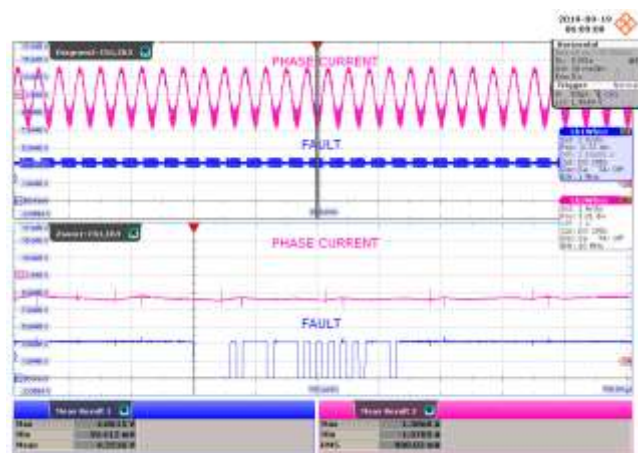

Figure 61 – System Thermal Fault, 5000 RPM, 300 W.

CH3: I_{PHASE} , 1 A / div.
 CH1: V_{FAULT} , 2 V / div.
 Time Scale: 20 ms / div.
 Time Scale (Zoomed Area): 100 μ s / div.
 FAULT Flag/Reading = 1100000.

7.7 **Abnormal Motor Operation Test**

This paragraph provides results during abnormal operation tests for appliances with motors as described in IEC 60335-1 (Safety of household and similar electrical appliances). The test includes:

- Operation under stalled motor conditions
- Operation with one motor winding disconnected
- Running overload test

The test results demonstrate the integrated protection features of the BridgeSwitch under such abnormal operations.

7.7.1 **Operation Under Stalled (Motor) Conditions**

For the motor stalled condition, the inverter is initially running at 340 VDC, 200 W and 300 W output load, and a motor speed of 5000 RPM. The load was then ramped up drastically to simulate sudden brake or sudden stoppage of motor rotation.

Stalled Condition at 200 W



Figure 62 – At Stalled Condition, 200 W Load.

CH1: $I_{PHASE(U)}$, 2 A / div.
 CH2: $I_{PHASE(V)}$, 2 A / div.
 CH3: $I_{PHASE(W)}$, 2 A / div.
 CH4: V_{FAULT} , 1 V / div.
 Time Scale: 500 ms / div.
 Time Scale (Zoomed): 100 μ s / div.
 1st FAULT = 0000010, LS FET OC.

Stalled Condition at 300 W

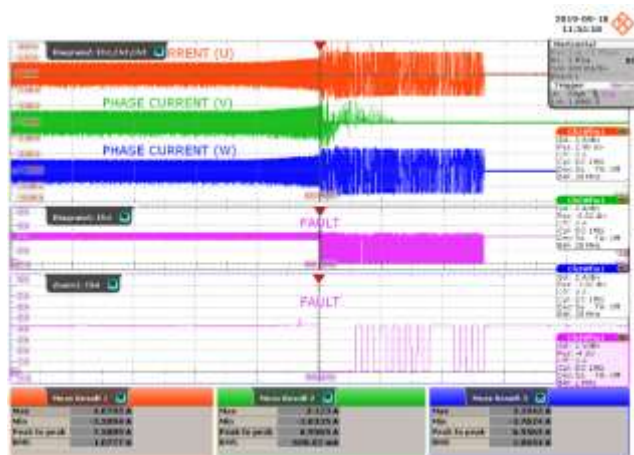

Figure 63 – At Stalled Condition, 300 W Load.

CH1: $I_{PHASE(U)}$, 2 A / div.
 CH2: $I_{PHASE(V)}$, 2 A / div.
 CH3: $I_{PHASE(W)}$, 2 A / div.
 CH4: V_{FAULT} , 1 V / div.
 Time Scale: 500 ms / div.
 Time Scale (Zoomed): 100 μ s / div.
 1st FAULT = 0000010, LS FET OC.

7.7.2 Operation with One Motor Phase / Winding Disconnected

The figures below depict the motor phase currents and fault flag during operation with one motor winding disconnected. One phase is disconnected during running condition at 200 W and 300 W load (at 340 VDC input, and a motor speed of 5000 RPM). Reconnection of phase was also tested per loading condition to determine the robustness of the BridgeSwitch inverter. No damage was incurred in the motor, as well as in the BridgeSwitch inverter during and after the test.

One Phase Disconnected at 200 W



Figure 64 – At Running Condition, 340 VDC Input.

CH1: $I_{PHASE(U)}$, 2 A / div.
 CH2: $I_{PHASE(V)}$, 2 A / div.
 CH3: $I_{PHASE(W)}$, 2 A / div.
 CH4: V_{FAULT} , 1 V / div.
 Time Scale: 100 ms / div.
 Time Scale (Zoomed FAULT): 100 μ s / div.
 FAULT Flag = 0000010, LS FET OC.

One Phase Reconnected at 200 W

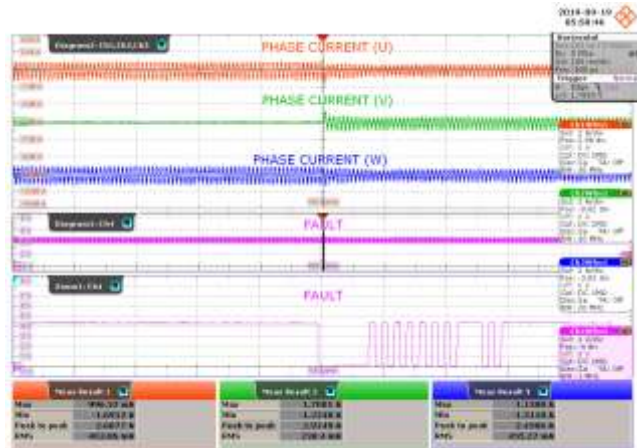

Figure 65 – At Running Condition, 340 VDC Input.

CH1: $I_{PHASE(U)}$, 2 A / div.
 CH2: $I_{PHASE(V)}$, 2 A / div.
 CH3: $I_{PHASE(W)}$, 2 A / div.
 CH4: V_{FAULT} , 1 V / div.
 Time Scale: 100 ms / div.
 Time Scale (Zoomed FAULT): 100 μ s / div.
 FAULT Flag = 0000001, HS FET OC.

One Phase Disconnected at 300 W



Figure 66 – At Running Condition, 340 VDC Input.

CH1: $I_{\text{PHASE(U)}}$, 2 A / div.

CH2: $I_{\text{PHASE(V)}}$, 2 A / div.

CH3: $I_{\text{PHASE(W)}}$, 2 A / div.

CH4: V_{FAULT} , 1 V / div.

Time Scale: 100 ms / div.

Time Scale (Zoomed FAULT): 100 μs / div.

FAULT Flag = 0000010, LS FET OC.

Note: During 300 W loss of phase condition, the motor stops rotating or remains in stalled condition even when the phase is reconnected.

7.7.3 **Running Overload Test**

The figures below depict the motor phase currents and status update flag during a running overload fault condition. During this test, the motor load is increased such that the current through the motor windings increases by 10% and until steady conditions are established. The load is then increased again and the test repeats until the BridgeSwitch protection engages or the motor stalls. During the overload condition, the motor is non-operational with no device or motor damage.

Overload Test >300 W



Figure 67 – At Running Condition, 340 VDC Input.

CH1: $I_{PHASE(U)}$, 2 A / div.

CH2: $I_{PHASE(V)}$, 2 A / div.

CH3: $I_{PHASE(W)}$, 2 A / div.

CH4: V_{FAULT} , 1 V / div.

Time Scale: 100 ms / div.

Time Scale (Zoomed FAULT): 100 μ s / div.

1st FAULT Flag = 0000010, LS FET Over-Current.

Note: During overload condition, the motor stops rotating or remains in stalled condition.

8 Appendix

8.1 Board Quick Reference

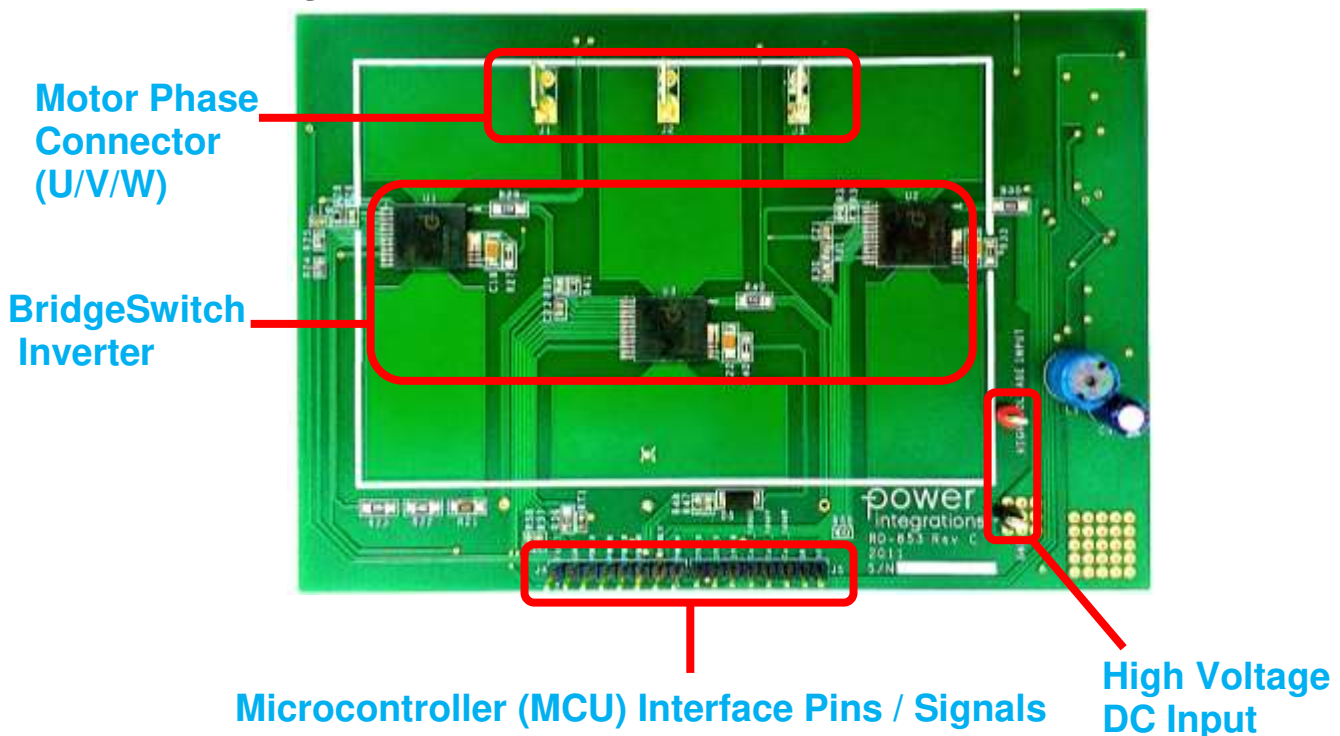

Figure 68 – RD-853 Board Quick Reference /Guide.

8.1.1 The Microcontroller (MCU) Interface Contains the Following Pins / Signals

- **FAULT_BUS** – Pin dedicated for fault reporting of all BridgeSwitch devices.
- **GND** – Common ground interface between the microcontroller and the inverter board.
- **PWMH_U, PWML_U, PWMH_V, PWML_V, PWMH_W, and PWML_W** – PWM input signal interface from the system microcontroller to the BridgeSwitch device.
- **+5 V** – Voltage supply pin for the microcontroller as needed.
- **SM** – Configurable system monitoring pin for BridgeSwitch IC (U2).
- **Curr_fdbkU, Curr_fdbkV, Curr_fdbkW** – Current feedback information needed by the microcontroller (MCU). This signal directly comes from the inverter current sense resistor passing through the current sense amplifier circuit.
- **IPH_U, IPH_V, IPH_W** – Instantaneous phase current information of the low-side power FREDFET Drain-to-Source current of each BridgeSwitch device coming from the IPH pin.

Note: On the RD board, proper labels for the pin designations of connectors are provided.



8.1.2 **J4 Connector Pin Designation**

Pin No.	Signal	Type	Comments
1	PWML_V	Input	Gate drive signal for low-side power FREDFET phase V.
2	PWMH_V	Input	Gate drive signal for high-side power FREDFET phase V.
3	PWML_W	Input	Gate drive signal for low-side power FREDFET phase W.
4	PWMH_W	Input	Gate drive signal for high-side power FREDFET phase W.
5	PWML_U	Input	Gate drive signal for low-side power FREDFET phase U.
6	PWMH_U	Input	Gate drive signal for high-side power FREDFET phase U.
7	GND	n/a	Ground reference for connector input and output signals.
8	FAULT_BUS	Input/Output	Single wire, bi-directional fault communication bus.

8.1.3 **J5 Connector Pin Designation**

Pin No.	Signal	Type	Comments
1	IPH_U	Output	Voltage signal proportional to the instantaneous phase low-side FREDFET Drain current of Phase U.
2	IPH_V	Output	Voltage signal proportional to the instantaneous phase low-side FREDFET Drain current of Phase V.
3	IPH_W	Output	Voltage signal proportional to the instantaneous phase low-side FREDFET Drain current of Phase W.
4	Curr_fdbkU	Output	Current feedback information needed by the microcontroller for phase U.
5	Curr_fdbkV	Output	Current feedback information needed by the microcontroller for phase V.
6	Curr_fdbkW	Output	Current feedback information needed by the microcontroller for phase W.
7	SM_W	Input	External input for system sensing (i.e. can be connected to an external thermistor for system temperature monitor via status communication bus)
8	+5 V	Output	Voltage supply pin for the microcontroller as needed

Note: On the RD board, proper labels for the pin designations of connectors are provided.

8.2 Recommended Start-up Sequence

BridgeSwitch devices have internal self-supply supporting commutation PWM frequencies up to 20 kHz. To ensure sufficient supply voltage levels across the BPL pin capacitor and the BPH pin capacitor at inverter start-up, the system microcontroller (MCU) should follow the recommended power-up sequence as depicted below.

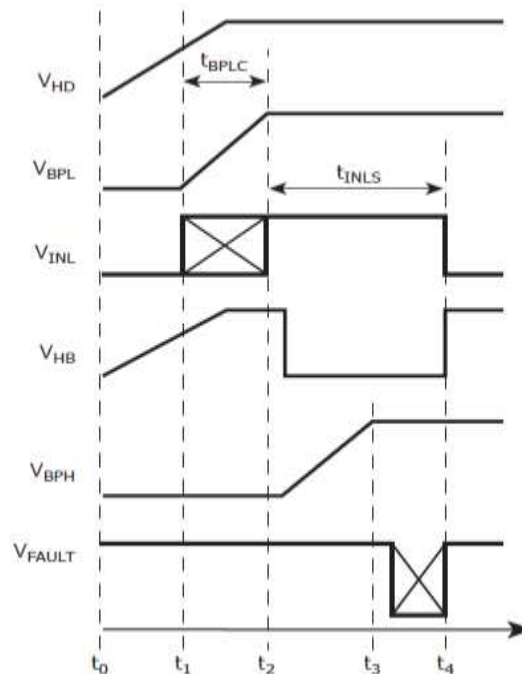

Figure 69 – Recommended Power-up Sequence with Self-Supplied Operation.

The table below lists activities occurring during the recommended power-up sequence.

Time Point	Activity
t_0	<ul style="list-style-type: none"> High-voltage DC bus is applied
t_1	<ul style="list-style-type: none"> Internal current source starts charging BPL pin capacitor once HD pin voltage reaches $V_{HD(START)}$ System MCU may start setting low-side power-FREDFET control signal INL to high
t_2	<ul style="list-style-type: none"> BPL pin voltage reaches V_{BPL} (typ. 14.5 V) Device determines external device settings Internal Gate drive logic turns on low-side power FREDFET after device setup completes and once INL becomes high or if it is already high Internal current source charges BPH pin capacitor
t_3	<ul style="list-style-type: none"> BPH pin voltage reaches V_{BPH} with respect to the HB pin (typically 14.5 V) Device starts communicating successful power-up through fault pin Note: The device does not send a status update if the internal power-up sequence did not complete successfully
t_4	<ul style="list-style-type: none"> BridgeSwitch is ready for state operation (indicated by communicated status update at time point t_3) System MCU turns off low-side FREDFET

Table 4 – Power-up Sequence with Self-Supplied Operation.

8.3 Status Word Encoding

FAULT	Bit 0	Bit 1	Bit 2	Bit 3	Bit 4	Bit 5	Bit 6
HV Bus OV	0	0	1				
HV Bus UV 100%	0	1	0				
HV Bus UV 85%	0	1	1				
HV Bus UV 70%	1	0	0				
HV Bus UV 55%	1	0	1				
System Thermal Fault	1	1	0				
LS Driver Not Ready ^[1]	1	1	1				
LS FET Thermal Warning				0	1		
LS FET Thermal Shutdown				1	0		
HS Driver Not Ready ^[2]				1	1		
LS FET Over-Current						1	
HS FET Over-Current							
Device Ready (No Faults)	0	0	0	0	0	0	0

Notes:

1. Includes XL pin open/short circuit fault, IPH pin to XL pin short-circuit, and trim bit corruption
2. Includes HS-to-LS communication loss, V_{BPH} or internal 5 V rail out of range, and XH pin open/short-circuit fault

Table 5 – BridgeSwitch Fault Encoding.

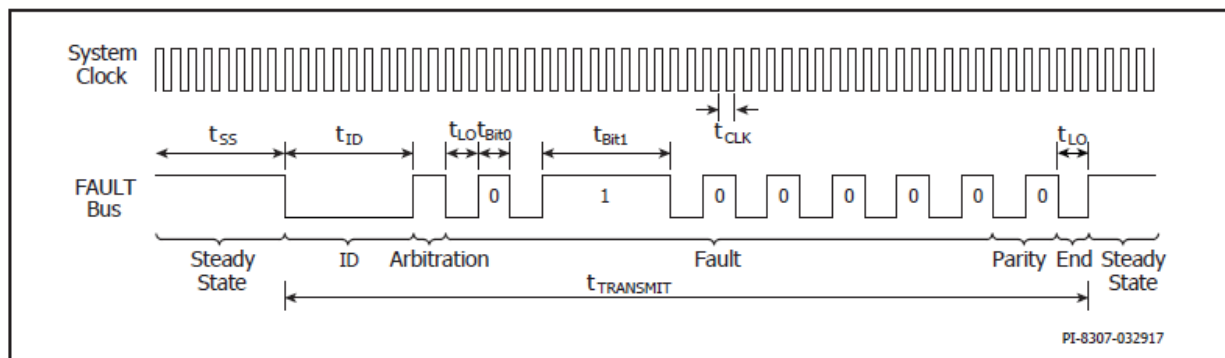

Figure 70 – Fault Status Communication Bit Stream.

8.4 ***Suggested Microcontroller Actions to BridgeSwitch Fault Conditions***

Fault	Fault ID	Action/Decision
HV Bus Overvoltage	001xxxx	Shutdown
HV 100%	010xxxx	Warning
HV Bus 85%	011xxxx	Warning
HV Bus 70%	100xxxx	Warning
HV Bus 55%	101xxxx	Warning
System Thermal	110xxxx	Shutdown
LS Driver Not Ready	111xxxx	Shutdown
LS FET Thermal Warning	xxx010x	Warning
LS FET Thermal Shutdown	xxx10xx	Shutdown
LS FET Over-Current	xxxxx1x	Shutdown
HS Driver Not Ready	xxx11xx	Shutdown
HS FET Over-Current	xxxxxx1	Shutdown
Device Ready	0000000	None



8.5 *Inverter Output Power Measurement*

The three-phase inverter output power (P_{OUT}) measurement uses the “two-wattmeter” method as illustrated below.

$$P_{OUT} = P_{CH1} + P_{CH2}$$

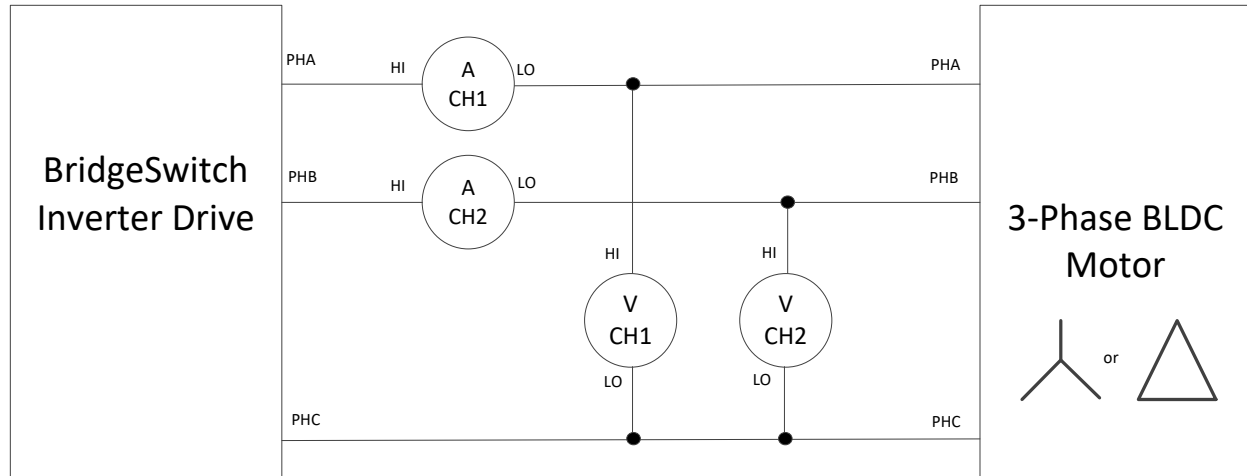

Figure 71 – Inverter Output Power Measurement.

8.6 *Current Capability vs. Ambient Temperature*

The figure below depicts the continuous RMS current capability of the RDR-853 example design under different operation conditions: 5 kHz, 12 kHz, and 16 kHz PWM frequency and the three BRD1265C devices operating self-supplied or with external supply at their respective BPL and BPH pins. The DC bus voltage is 340 VDC and the motor is operating at a speed of 5000 RPM. The inverter board is enclosed in an acrylic case to minimize the effects of air flow to the thermal behavior of the BridgeSwitch devices. Each curve details the available continuous RMS current at different board ambient temperatures with a package temperature of 100 °C (average of all three devices).

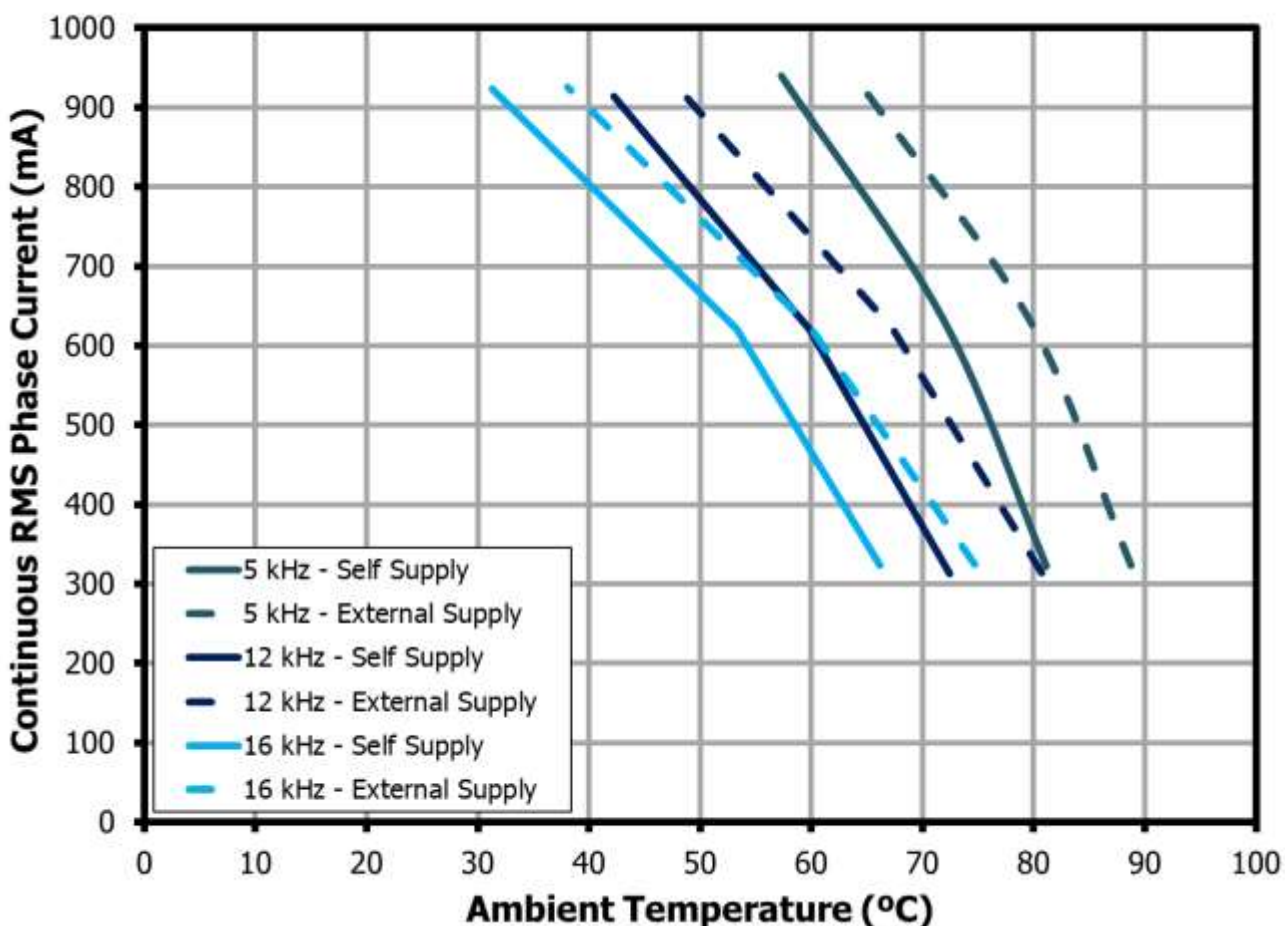

Figure 72 – Current Capability vs. Ambient Temperature (Max. 100 °C Package Temperature).

8.7 Efficiency Curves at Different Switching Frequencies

The graph and table below shows the BridgeSwitch inverter efficiency at 340 VDC input, 5 kHz, 12 kHz, 16 kHz PWM switching frequencies, a constant motor speed of 5000 RPM, three-phase FOC modulation, BridgeSwitch devices at self and external supply mode, and at an average ambient temperature of 28 °C. The auxiliary circuit, +5 V linear regulator, and input diode were disabled for efficiency data accuracy. This was accomplished by measuring the input voltage directly at the positive input DC BUS of the inverter, and depopulating components U4, U5, and D6. An external +5 VDC supply was provided between pins +5 V and GND for the microcontroller and current sense amplifier. An external +17 VDC supply was used during external supply mode for the bypass pin supply.

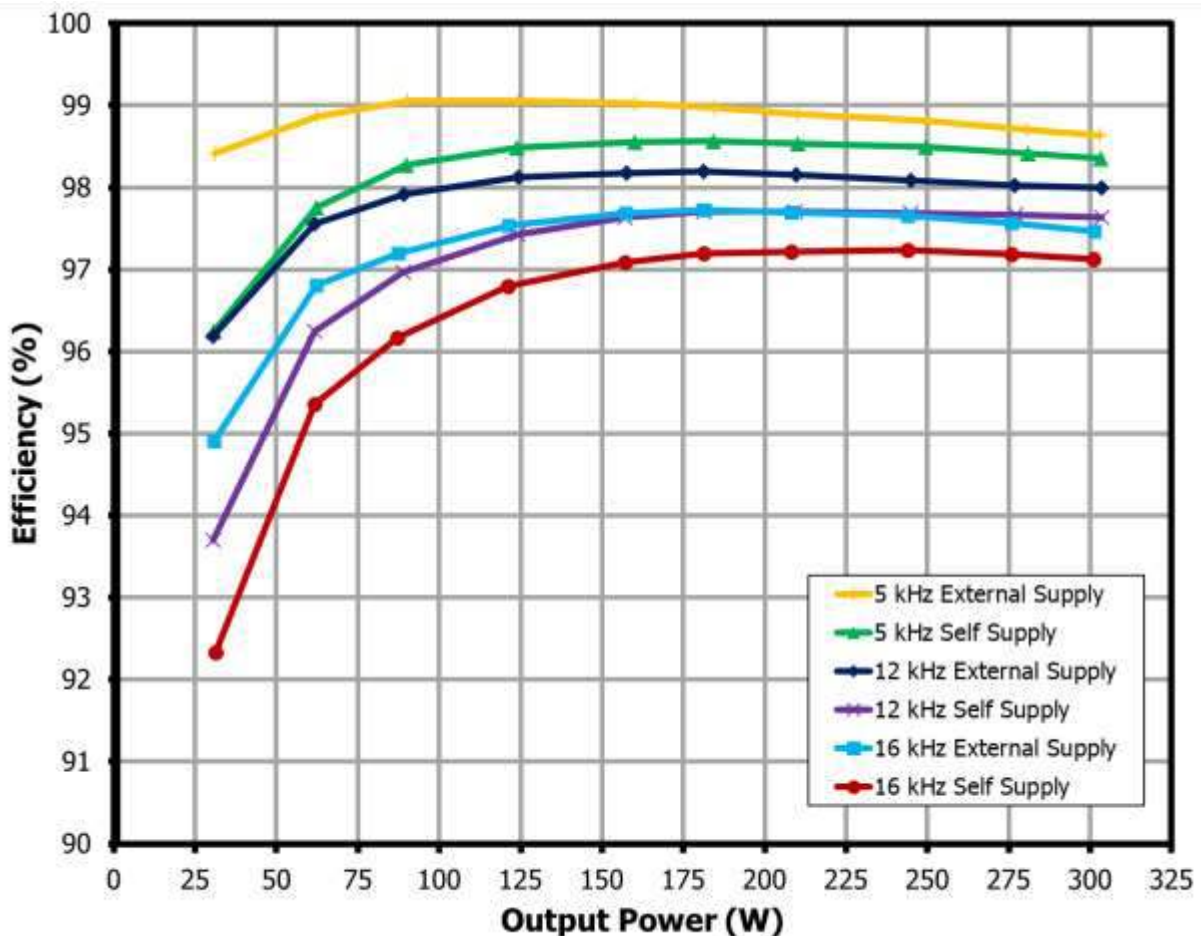

Figure 73 – Inverter Efficiency Graph.



8.8 Test Bench Set-up

This setup improves the accuracy of all thermal measurements. The inverter board is enclosed in an acrylic case to minimize the effects of air flow to the thermal behavior of the BridgeSwitch devices. A digital multimeter with a thermocouple probe placed three inches above the inverter board is used for ambient temperature monitoring.

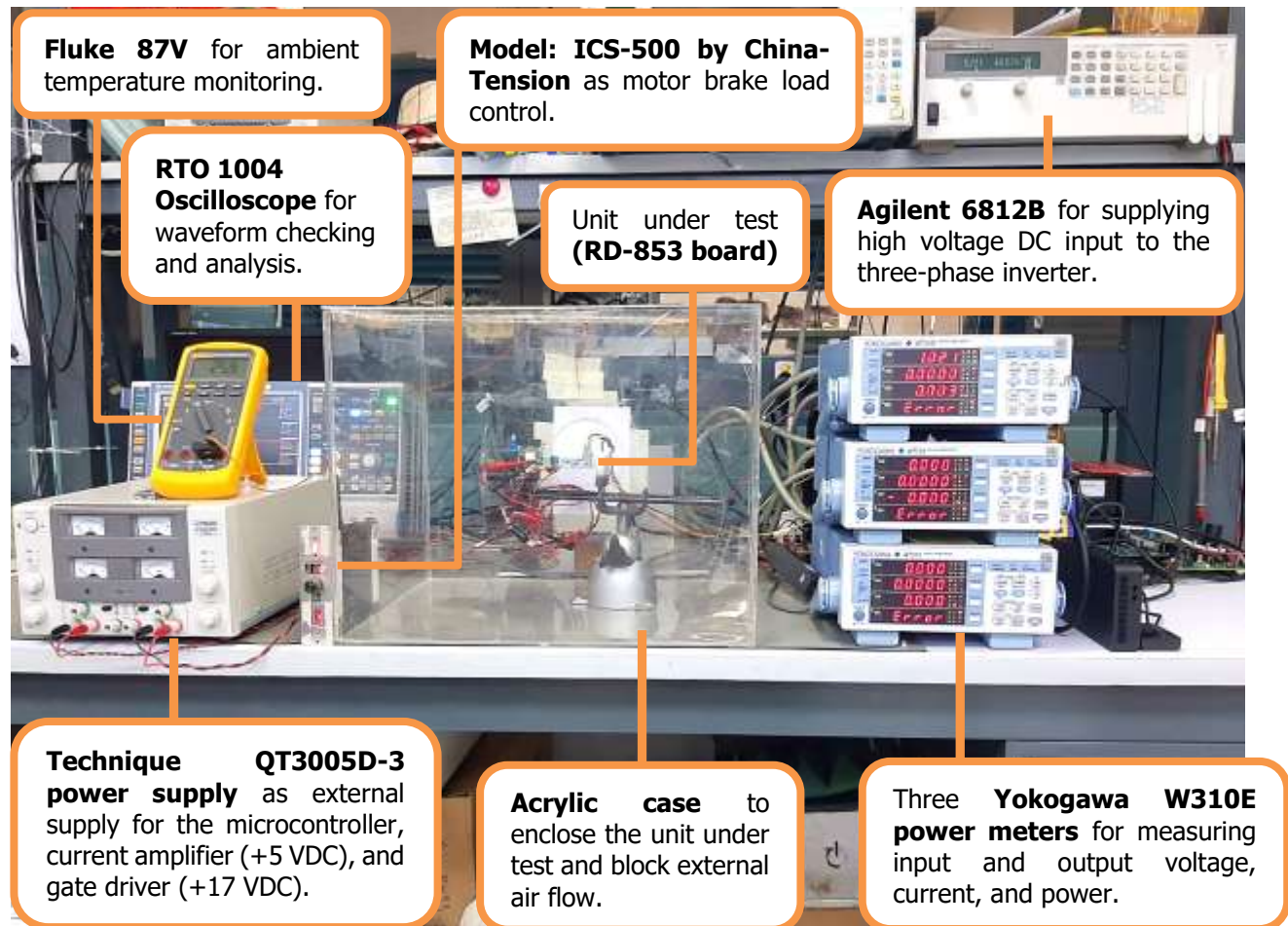

Figure 74 – Actual Bench Set-up.

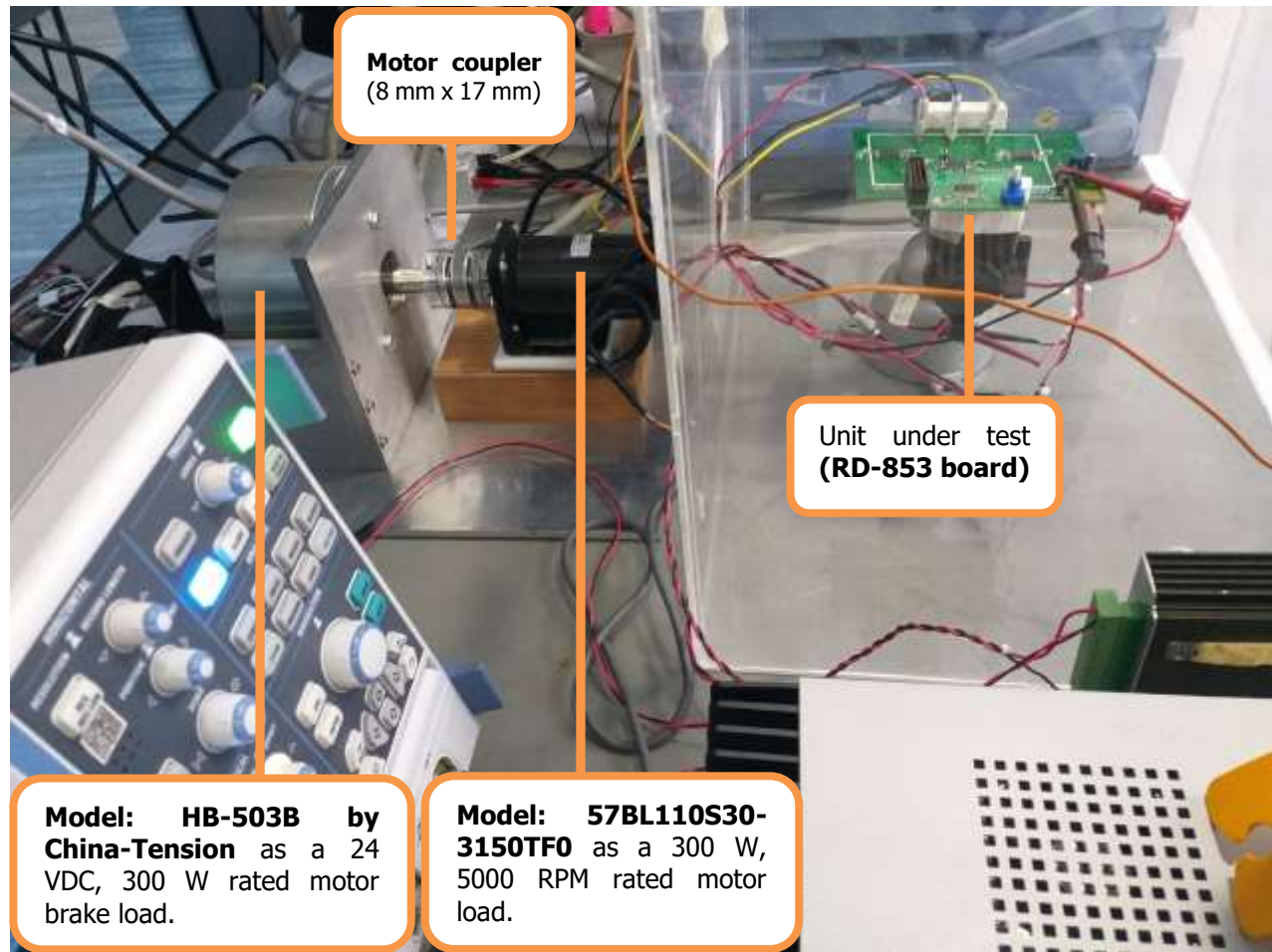

Figure 75 – Actual Bench Set-up.

8.8.1 *Equipment Used*

1. **Motor (Model: 57BL110S30-3150TF0)** – as a 300 W, 5000 RPM rated motor.
2. **Motor brake load (Model: HB-503B by China-Tension)** – as a 24 VDC, 300 W rated motor brake load.
3. **Brake load control (Model: ICS-500 by China-Tension)** – as a 24 VDC, 500 mA rated brake load control.
4. **Coupler** – as a 8 mm x 17 mm motor coupler.
5. **High-voltage DC source (Agilent 6812B)** – for supplying high-voltage DC input to the three-phase inverter.
6. **Low-voltage DC source (Technique QT3005D-3)** – as external supply for the microcontroller, current amplifier (+5 VDC), and gate driver (+17 VDC).
7. **Oscilloscope (RTO 1004)** – for waveform checking and analysis.
8. **Digital Multimeter (Fluke 87V)** – for ambient temperature monitoring.
9. **Power Meter (WT310E)** – for measuring input and output voltage, current, and power.

9 Revision History

Date	Author	Rev.	Description & Changes	Approval
05-Jun-20	MQC	1.0	Initial Release.	Apps & Mktg
08-Jul-20	SM	1.1	Schematic, PCB and Various Updates.	Apps & Mktg
13-May-21	SM	1.2	Thermals and Efficiency Updates – Closed Case Setup.	Apps & Mktg
16-Jun-22	SM	1.3	Added modulation scheme information.	Apps & Mktg



For the latest updates, visit our website: www.power.com

Reference Designs are technical proposals concerning how to use Power Integrations' gate drivers in particular applications and/or with certain power modules. These proposals are "as is" and are not subject to any qualification process. The suitability, implementation and qualification are the sole responsibility of the end user. The statements, technical information and recommendations contained herein are believed to be accurate as of the date hereof. All parameters, numbers, values and other technical data included in the technical information were calculated and determined to our best knowledge in accordance with the relevant technical norms (if any). They may base on assumptions or operational conditions that do not necessarily apply in general. We exclude any representation or warranty, express or implied, in relation to the accuracy or completeness of the statements, technical information and recommendations contained herein. No responsibility is accepted for the accuracy or sufficiency of any of the statements, technical information, recommendations or opinions communicated and any liability for any direct, indirect or consequential loss or damage suffered by any person arising therefrom is expressly disclaimed.

Power Integrations reserves the right to make changes to its products at any time to improve reliability or manufacturability. Power Integrations does not assume any liability arising from the use of any device or circuit described herein. POWER INTEGRATIONS MAKES NO WARRANTY HEREIN AND SPECIFICALLY DISCLAIMS ALL WARRANTIES INCLUDING, WITHOUT LIMITATION, THE IMPLIED WARRANTIES OF MERCHANTABILITY, FITNESS FOR A PARTICULAR PURPOSE, AND NON-INFRINGEMENT OF THIRD PARTY RIGHTS.

Patent Information

The products and applications illustrated herein (including transformer construction and circuits' external to the products) may be covered by one or more U.S. and foreign patents, or potentially by pending U.S. and foreign patent applications assigned to Power Integrations. A complete list of Power Integrations' patents may be found at www.power.com. Power Integrations grants its customers a license under certain patent rights as set forth at <http://www.power.com/ip.htm>.

Power Integrations, the Power Integrations logo, CAPZero, ChiPhy, CHY, DPA-Switch, EcoSmart, E-Shield, eSIP, eSOP, HiperPLC, HiperPFS, HiperTFS, InnoSwitch, Innovation in Power Conversion, InSOP, LinkSwitch, LinkZero, LYTSwitch, SENZero, TinySwitch, TOPSwitch, PI, PI Expert, SCALE, SCALE-1, SCALE-2, SCALE-3 and SCALE-iDriver, are trademarks of Power Integrations, Inc. Other trademarks are property of their respective companies. ©2018, Power Integrations, Inc.

Power Integrations Worldwide Sales Support Locations**WORLD HEADQUARTERS**

5245 Hellyer Avenue
San Jose, CA 95138, USA.
Main: +1-408-414-9200
Customer Service:
Worldwide: +1-65-635-64480
Americas: +1-408-414-9621
e-mail: usasales@power.com

China (Shanghai)

Rm 2410, Charity Plaza, No. 88,
North Caoxi Road,
Shanghai, PRC 200030
Phone: +86-21-6354-6323
e-mail: chinasales@power.com

CHINA (SHENZHEN)

17/F, Hivac Building, No. 2,
Keji Nan 8th Road, Nanshan
District, Shenzhen, China,
518057
Phone: +86-755-8672-8689
e-mail: chinasales@power.com

GERMANY (AC-DC/LED Sales)

Lindwurmstrasse 114
D-80337 München
Germany
Phone: +49-89-5527-39100
e-mail: eurosales@power.com

GERMANY (Gate Driver Sales)

HellwegForum 1
59469 Ense
Germany
Tel: +49-2938-64-39990
e-mail: igbt-driver.sales@power.com

INDIA

#1, 14th Main Road
Vasanthanagar
Bangalore-560052
India
Phone: +91-80-4113-8020
e-mail: indiasales@power.com

ITALY

Via Milanese 20, 3rd Fl.
20099 Sesto San Giovanni (MI) Italy
Phone: +39-024-550-8701
e-mail: eurosales@power.com

JAPAN

Yusen Shin-Yokohama 1-chome Bldg.
1-7-9, Shin-Yokohama, Kohoku-ku
Yokohama-shi,
Kanagawa 222-0033 Japan
Phone: +81-45-471-1021
e-mail: japansales@power.com

KOREA

RM 602, 6FL
Korea City Air Terminal B/D,
159-6
Samsung-Dong, Kangnam-Gu,
Seoul, 135-728 Korea
Phone: +82-2-2016-6610
e-mail: koreasales@power.com

SINGAPORE

51 Newton Road,
#19-01/05 Goldhill Plaza
Singapore, 308900
Phone: +65-6358-2160
e-mail:
singaporesales@power.com

TAIWAN

5F, No. 318, Nei Hu Rd.,
Sec. 1
Nei Hu District
Taipei 11493, Taiwan R.O.C.
Phone: +886-2-2659-4570
e-mail: taiwansales@power.com

UK

Building 5, Suite 21
The Westbrook Centre
Milton Road
Cambridge
CB4 1YG
Phone: +44 (0) 7823-557484
e-mail: eurosales@power.com

