

REV. REVISIONS		RELEASED	
REV.	DESCRIPTION	DATE	APPROVED
F	25025 REDRAWN TO CAEDS; ADDED ITS. 13 & 14	11-5-93	WS
G	11-024834 ITEM 6 WAS -054	11-12-01	CB
H	14-017424 MAX WEIGHT WAS 10 OZ.	14-11-18	MDM
J	17-004355 MAX WEIGHT WAS 1 LB. 10.5 OZ.	17-03-28	RS

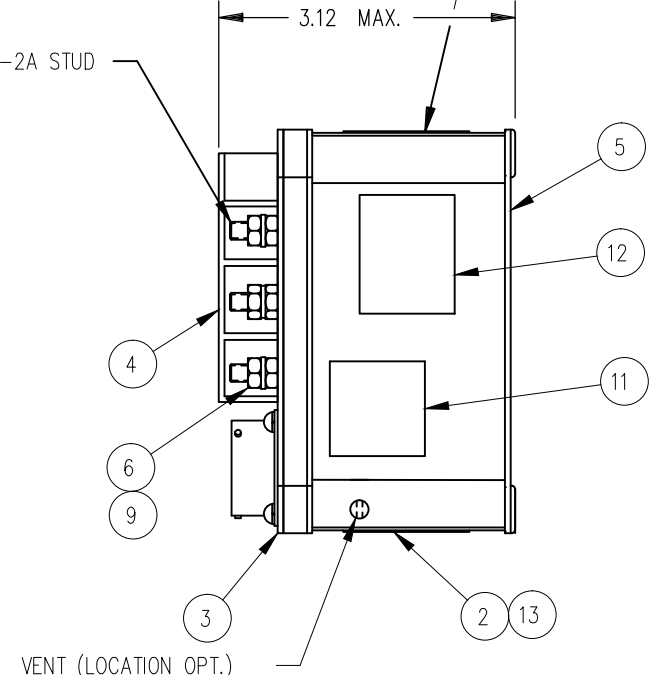

NOMINAL OPERATING VOLTAGE	28 VDC
COIL A-B	28 VDC
COIL C-B	120/208 VOLT 400 HZ
CONTACTS	
PICKUP VOLTAGE	18V MAX (HOT)
DROPOUT VOLTAGE	7 + 0, -5.5 VDC
CONTACT ARRANGEMENT	TPDT NO
CONTACT RATING	
RESISTIVE	60 AMP AC
INDUCTIVE	60 AMP AC
MOTOR	40 AMP AC
COIL CURRENT AT NOM. VOLTAGE	
INRUSH	5.0 AMP
HOLDING	.35 AMP
PICKUP TIME	15 MS MAX.
DROPOUT TIME	10 MS MAX.
MIN OPERATING PERIOD	3 HRS.
MIN OPERATING CYCLES	50,000
MAX AMBIENT TEMPERATURE	71°C
AUX CONTACT RATING	5 AMP RES., 28 VDC
MAX WEIGHT	1.75 LBS

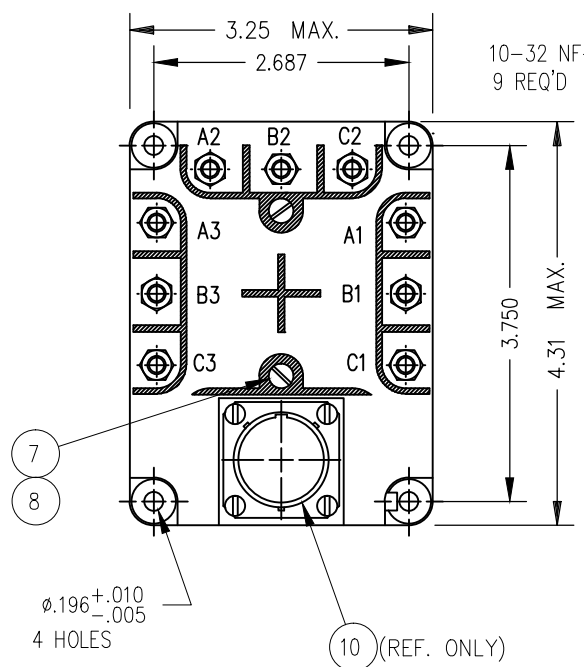
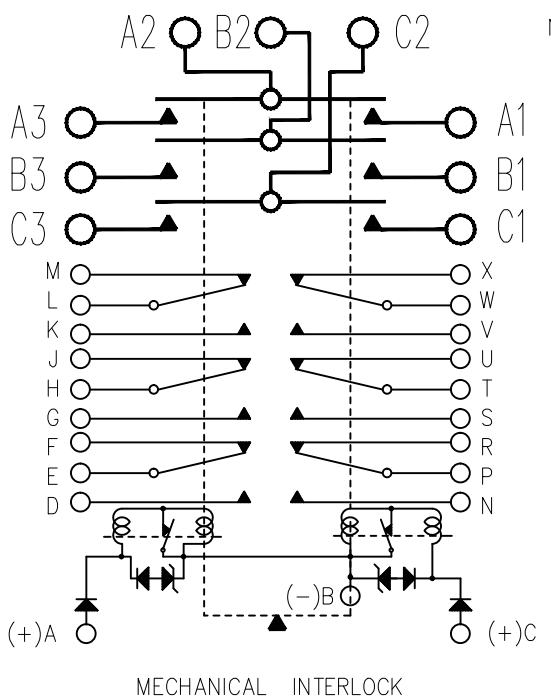

- NOTES:
1. STAMP "WARNING - HIGH VOLTAGE" ON SHIELD.
 2. COIL TRANSIENT LIMITED TO A-75 VDC.
 3. CONTRACTOR CAPABLE OF TRANSFERING UNSYNCHRONIZED SOURCES.

FIND NO	QTY REQD	PART OR IDENTIFYING NO	NOMENCLATURE OR DESCRIPTION	FSCM NO	DRAWING OR SPECIFICATION	MATERIAL OR NOTE
14	1	39529-009	OVERLAY			
13	1	39529-001	OVERLAY			
12	1	25695-001	PLATE - WARNING			
11	1	12771-001	PLATE - WARNING			
10	-	52516-005	CONNECTOR - BENDIX		MS3112E-16-23P	
9	9	51810-054	WASHER - LOCK NO.10 .062 X .047		AN935B10	BRONZE
8	2	51806-031	WASHER - LOCK NO.6 INT.		AN936A6B	BRONZE
7	2	51206-644	SCREW - 6-32 X 3/4 RD. HD.			BRASS
6	9	50410-174	NUT - 10-32 X 5/16 X 9/64 HEX.			BRASS
5	1	34929-020	CONTACTOR ASSEMBLY - PRIMARY			
4	1	22295-001	SHIELD - TERMINAL			
3	1	22261-001	PLATE - BASE COVER			
2	1	16043-001	PLATE - NAME			
1	1	34925-001	PLATE - WIRING DIAGRAM			

UNLESS OTHERWISE SPECIFIED DIMENSIONS ARE IN INCHES TOLERANCES ON

2 PL DEC.	3 PL DEC.	ANGLES
±.03	±.010	± 1'

DR BY HEA 93/12/29
 CHK BY WS 94/01/05
 ENGR KLK 94/01/06
 MFG JF 94/01/06

SIZE C CODE IDENT 74063

SCALE NONE SHEET

STE
 CONNECTIVITY
 Hartman Division -175 N. DIAMOND STREET MANSFIELD, OHIO 44802

CONTACTOR - TPDT NO
 093

DWG NO. B-140AP-1
 REF TE P/N 1616043-7