

COMPACT SLIDE SWITCHES



RoHS compliant



FEATURES

- Low-profile of 2 mm
- Self-return type available
- RoHS compliant

APPLICATIONS

- Mobile stereo · LCD TV · Camcorder

INTERNAL STRUCTURE

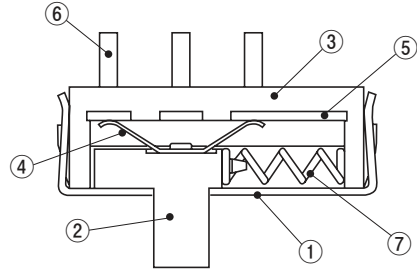

Part name	Material	Flammability
① Cover	Stainless steel (SUS 304)	—
② Slider	Liquid Crystal polymer	UL94V-0
③ Housing		
④ Slider contact	Copper alloy, Gold-plated	—
⑤ Fixed contact		
⑥ Terminal pin		
⑦ Return spring	SWP	

PART NUMBER DESIGNATION

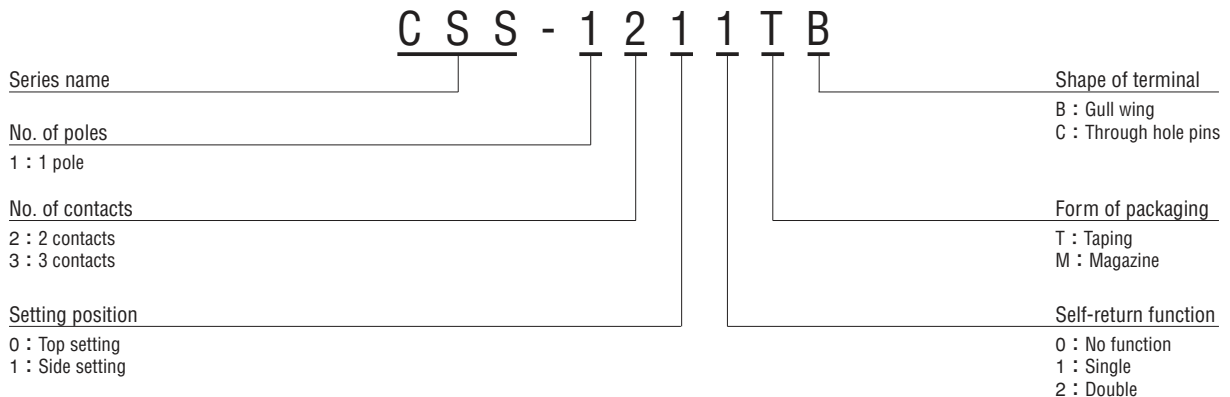

※ Please refer to the LIST OF PART NUMBERS when placing orders.

LIST OF PART NUMBERS

No. of contacts	Setting position	Self-return function	Shape of terminal	Form of packaging	Part number	Pieces in package
2	Side setting	No function	B (Gull wing)	Taping	CSS-1210TB	1,900 pcs./reel
			C (Through hole pins)	Magazine	CSS-1210MC	53 pcs./stick
		Single	B (Gull wing)	Taping	CSS-1211TB	1,900 pcs./reel
			C (Through hole pins)	Magazine	CSS-1211MC	53 pcs./stick
3	Side setting	No function	B (Gull wing)	Taping	CSS-1310TB	1,900 pcs./reel
			C (Through hole pins)	Magazine	CSS-1310MC	38 pcs./stick
		Single	B (Gull wing)	Taping	CSS-1311TB	1,900 pcs./reel
			C (Through hole pins)	Magazine	CSS-1311MC	38 pcs./stick
		Double	B (Gull wing)	Taping	CSS-1312TB	1,900 pcs./reel
			C (Through hole pins)	Magazine	CSS-1312MC	38 pcs./stick
	Top setting	No function	C (Through hole pins)	Magazine	CSS-1300MC	38 pcs./stick
		Double	C (Through hole pins)	Magazine	CSS-1302MC	38 pcs./stick

STANDARD SPECIFICATIONS

Operating temp. range	- 20 ~ 70 °C
Storage temp. range	- 40 ~ 85 °C
Sealing	Non- Washable
Net weight	Approx. 0.11 g (CSS-12), Approx. 0.15 g (CSS-13)

MECHANICAL CHARACTERISTICS

No. of positions	2, 3
Stroke	2 mm
Operating force	1 ~ 3.5 N {0.1 ~ 0.36 kgf}
Stop strength	10 N {1.02 kgf} 15 s (操作方向)
Solderability	245 ± 3 °C 2 ~ 3 s Sn-3Ag-0.5Cu
Soldering heat	Reflow : 250 ~ 255 °C (Peak temperature) (Please refer to the profile below)
	Manual soldering : 350 ± 10 °C, 3 ~ 4 s
Shear (Adhesion)	5 N {0.5 kgf} 10 s
Substrate bending	Width 90 mm, bend 3 mm, 5 s, 1 time
Pull-off strength	5 N {0.5 kgf} 10 s

{ } : Reference only

ELECTRICAL CHARACTERISTICS

Contact rating	Non-switching : DC50 V 100 mA Switching : DC12 V 100 mA Minimum : DC20 mV 1 μA
Contact timing	Non-shorting
Contact resistance	70 m Ω maximum
Insulation resistance	100 M Ω minimum (DC 500 V)
Dielectric strength	AC500 V 60 s

ENVIRONMENTAL CHARACTERISTICS

Vibration	Amplitude 1.5 mm or Acceleration 98 m/s ² , 10-500-10 Hz, 3 directions for 10 cycles each
Shock	490 m/s ² , 11 ms, 6 directions for 3 times each
Load life	Continuous load 10000 cycles, DC12 ± 0.5 V, 100 ± 10 mA
Humidity	40 °C, Relative humidity 90 ~ 95 %, 240 h, No load
High temp. exposure	85 °C, 96 h, No load
Low temp. exposure	- 40 °C, 96 h, No load
Thermal shock	- 40 (0.5 h) ~ 85 °C (0.5 h), 5 cycles

<Reflow profile for soldering heat evaluation>

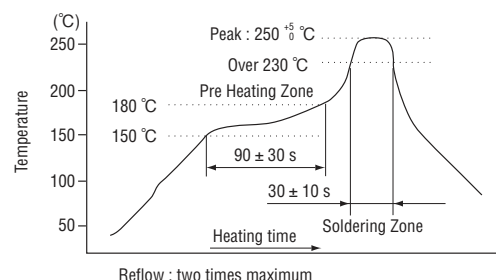

CSS

COMPACT SLIDE SWITCHES

OUTLINE DIMENSIONS

Unless otherwise specified, tolerance : ± 0.2 (Unit : mm)

● CSS-1210B

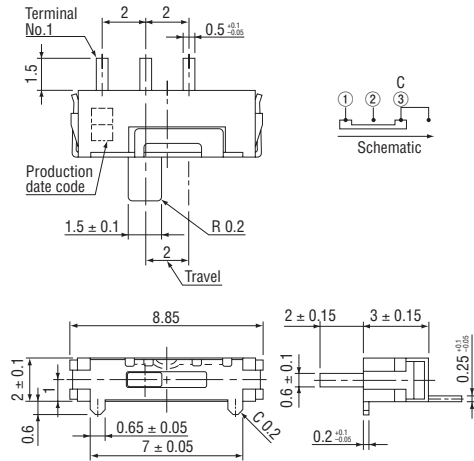

● CSS-1211B

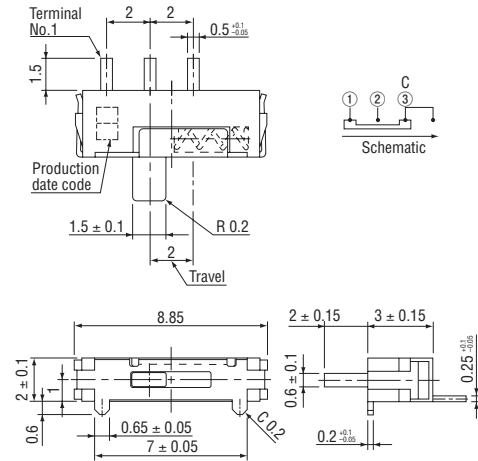

● CSS-1310B

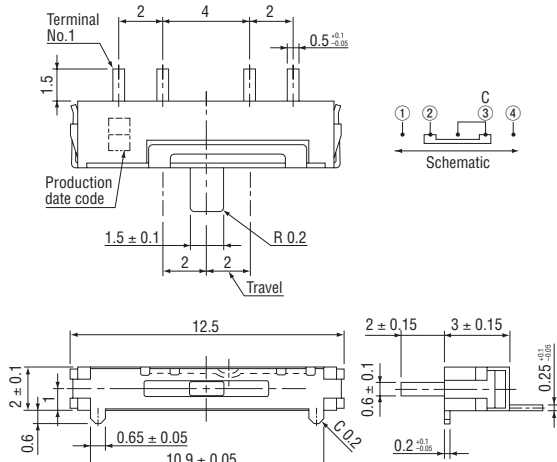

● CSS-1311B

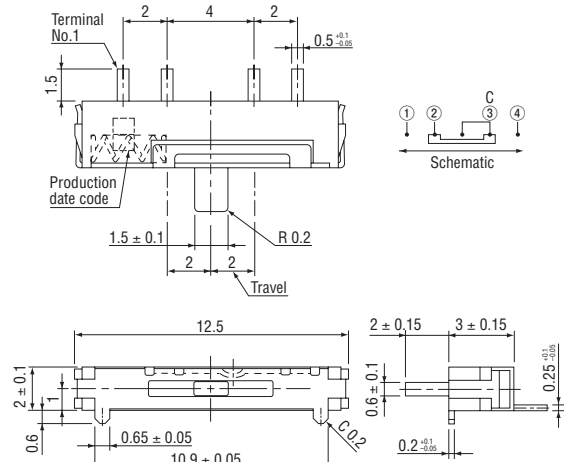

● CSS-1312B

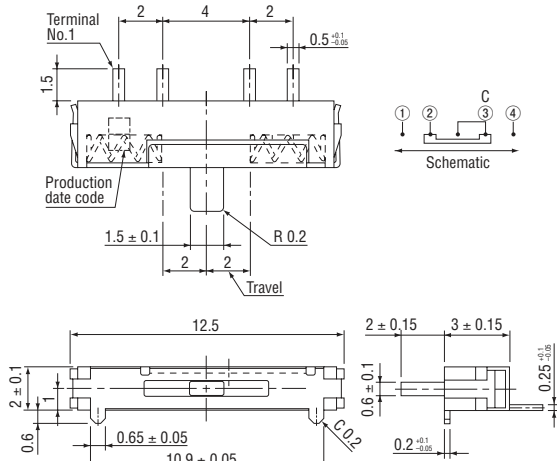

● CSS-1210C

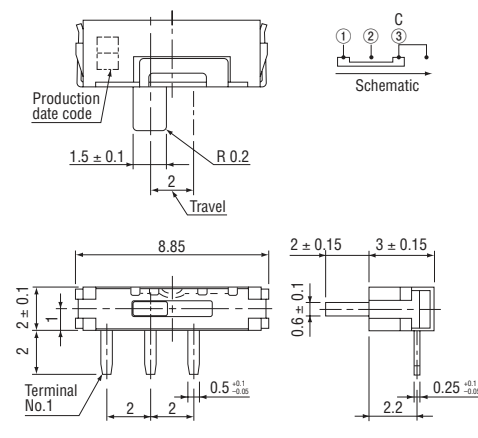

OUTLINE DIMENSIONS

Unless otherwise specified, tolerance : ± 0.2 (Unit : mm)

● **CSS-1211C**

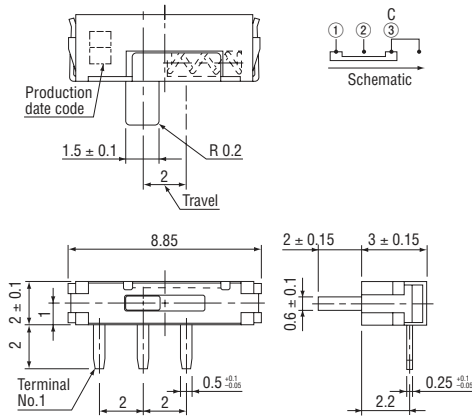

● **CSS-1310C**

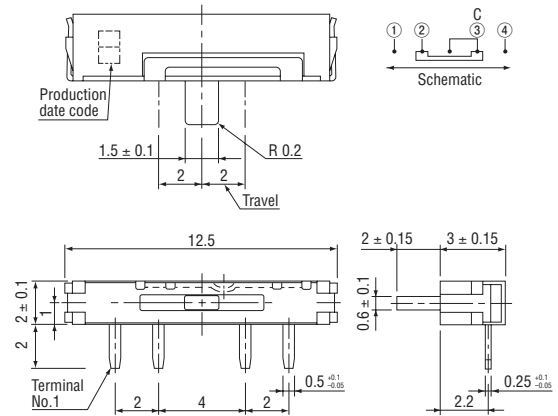

● **CSS-1311C**

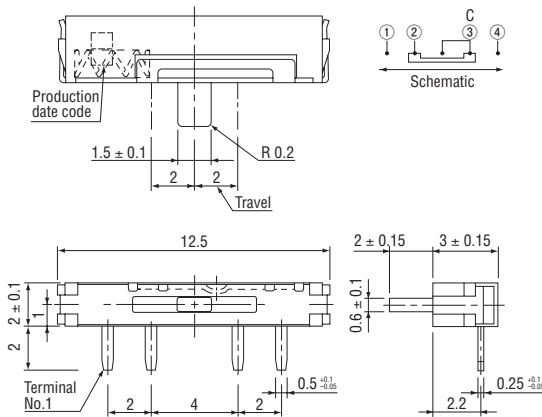

● **CSS-1312C**

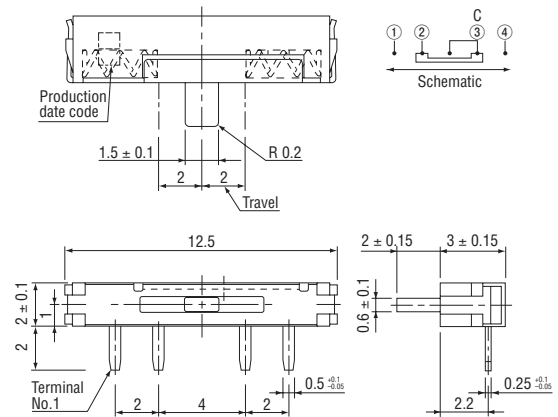

● **CSS-1300C**

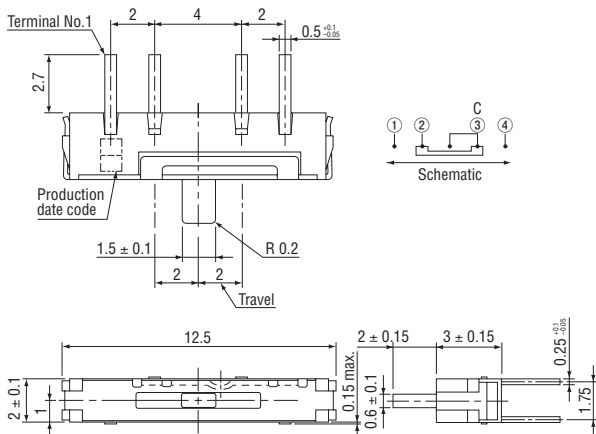

● **CSS-1302C**

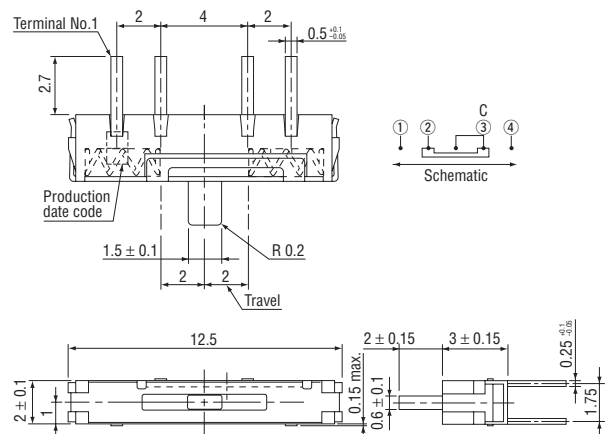

CSS

COMPACT SLIDE SWITCHES

RECOMMENDED P.C.B. PAD OUTLINE DIMENSIONS

● CSS-121 □ B

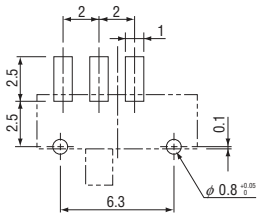

● CSS-131 □ B (Unit : mm)

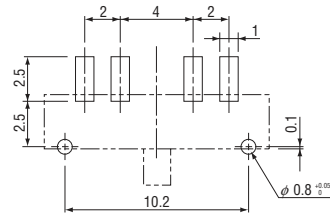

SIZE OF P.C.B. PROCESSING

● CSS-121 □ C

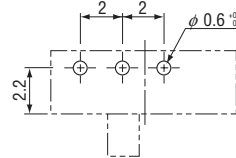

● CSS-131 □ C

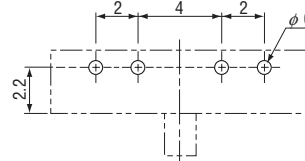

● CSS-130 □ C

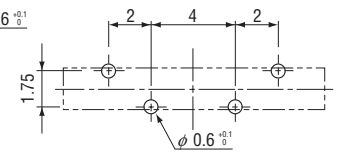

PACKAGING SPECIFICATIONS

Taping version is packaged in 1900 pcs. per reel.

Taping version is boxed with 1 reel (1900 pcs.).

Maximum number of consecutive missing pieces = 2.

Leader length and reel dimension are shown in the diagrams below.

Embossed tape dimensions

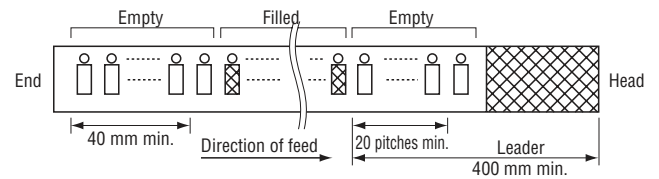

● CSS-121 □ TB

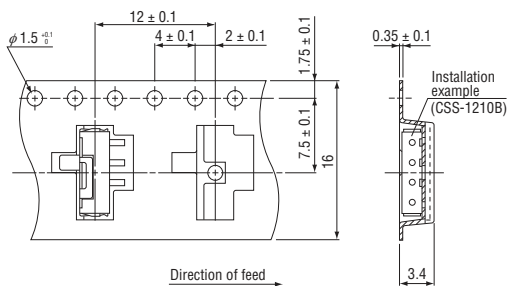

● CSS-131 □ TB

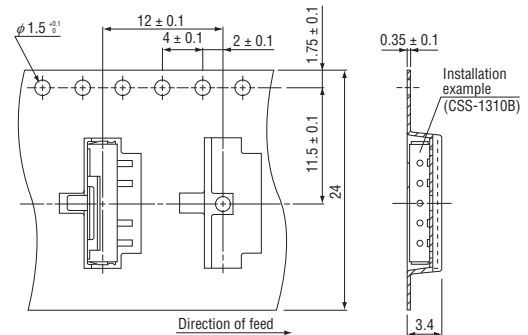

● Reel dimensions

(Unit: mm)

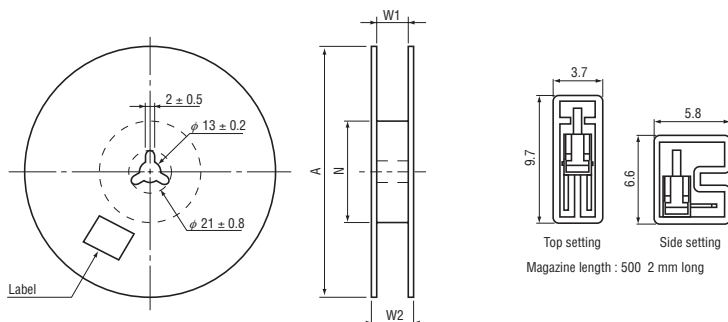

Packing quantity of magazine

Part number	A	W ₁	W ₂	N	Part number	Quantity / Stick
121 □ TB	φ 330 ± 2	17.4 ± 1	21.4 ± 1	φ 80 ± 1	12 □ □	53
131 □ TB	φ 330 ± 2	25.4 ± 1	29.4 ± 1	φ 80 ± 1	13 □ □	38