



| Parameter | Rating | Units |
|--------------------------------|-----------|-------|
| Breakdown Voltage - BV_{CEO} | 350 | V_P |
| Current Transfer Ratio - CTR | 1000-8000 | % |

Features

- $5000V_{rms}$ Input/Output Isolation
- $350V_P$ Breakdown Voltage
- Small 4-Pin Package
- Surface Mount Tape & Reel Version Available
- Flammability Rating UL 94 V-0

Applications

- Telecom Switching
- Tip/Ring Circuits
- Hook Switch
- Modem Switching (Laptop, Notebook, Pocket Size)
- Loop Detect
- Ringing Detect
- Current Sensing

Description

The CPC1301 is a unidirectional input optocoupler with a high-voltage Darlington output. Light output from the highly efficient infrared LED activates the optically coupled silicon NPN photo-Darlington output transistor. The input LED and the output transistor are separated by a $5000V_{rms}$ isolation barrier.

With a LED current of only 1mA, a current transfer ratio of 1000% to 8000% is guaranteed at the collector of the 350V Darlington output transistor.

The CPC1301's low input current, high current transfer ratio, high output voltage capability, and large isolation barrier rating make it ideal for many applications such as telecom, industrial, and power control.

Approvals

- UL 1577 Approved Component: File E76270
- CSA Certified Component: Certificate 1172007
- EN 60950 Certified Component:
Certificate available on our website

Ordering Information

| Part Number | Description |
|-------------|---------------------------------|
| CPC1301G | 4-Pin DIP (100/Tube) |
| CPC1301GR | 4-Pin Surface Mount (100/Tube) |
| CPC1301GRTR | 4-Pin Surface Mount (1000/Reel) |

Pin Configuration

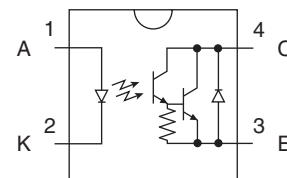

Absolute Maximum Ratings @ 25°C

| Parameter | Ratings | Units |
|--|-------------|-----------|
| Breakdown Voltage, BV_{CEO} | 350 | V_P |
| Reverse Input Voltage | 5 | V |
| Input Control Current | 50 | mA |
| Peak (10ms) | 1 | A |
| Input Power Dissipation ¹ | 150 | mW |
| Phototransistor Power Dissipation ² | 150 | mW |
| Isolation Voltage, Input to Output | 5000 | V_{rms} |
| Operational Temperature | -40 to +85 | °C |
| Storage Temperature | -40 to +125 | °C |

¹ Derate linearly 1.33 mW / °C

² Derate linearly 1.5 mW / °C

Absolute Maximum Ratings are stress ratings. Stresses in excess of these ratings can cause permanent damage to the device. Functional operation of the device at conditions beyond those indicated in the operational sections of this data sheet is not implied.

Typical values are characteristic of the device at +25°C, and are the result of engineering evaluations. They are provided for information purposes only, and are not part of the manufacturing testing requirements.

Electrical Characteristics @ 25°C

| Parameters | Conditions | Symbol | Min | Typ | Max | Units |
|---------------------------------------|-------------------------|---------------|------|------|------|---------|
| Output Characteristics | | | | | | |
| Phototransistor Breakdown Voltage | $I_{CEO}=100\mu A$ | BV_{CEO} | 350 | - | - | V_P |
| Emitter-Collector Breakdown Voltage | $I_E=0.1mA$ | BV_{ECO} | 0.3 | - | - | V |
| Phototransistor Output (Dark) Current | $V_{CEO}=200V, I_F=0mA$ | I_{CEO} | - | - | 100 | nA |
| Saturation Voltage | $I_C=10mA, I_F=1mA$ | $V_{CE(Sat)}$ | - | - | 1 | V |
| | $I_C=100mA, I_F=10mA$ | | - | - | 1.2 | |
| Current Transfer Ratio | $I_F=1mA, V_{CE}=1V$ | CTR | 1000 | 5500 | 8000 | % |
| Output Capacitance | $V_{CEO}=50V, f=1MHz$ | C_{OUT} | - | 13 | - | pF |
| Input Characteristics | | | | | | |
| Input Control Current | $I_C=10mA, V_{CE}=1V$ | I_F | - | 0.07 | 1 | mA |
| Input Voltage Drop | $I_F=5mA$ | V_F | 0.9 | 1.2 | 1.5 | V |
| Input Reverse Current | $V_R=5V$ | I_R | - | - | 10 | μA |
| Common Characteristics | | | | | | |
| Input to Output Capacitance | - | C_{IO} | - | 3 | - | pF |

Switching Characteristics @ 25°C

| Characteristic | Symbol | Test Condition | Typ | Units |
|----------------|-----------|-----------------|------|---------|
| Rise Time | t_R | $V_{CC}=10V$ | 40 | μS |
| Fall Time | t_F | | 2.6 | |
| Turn-On Time | t_{on} | $I_F=10mA$ | 2.75 | |
| Storage Time | t_S | $R_L=100\Omega$ | 20 | |
| Turn-Off Time | t_{off} | | 60 | |
| Turn-On Time | t_{on} | $V_{CC}=10V$ | 1 | |
| Storage Time | t_S | $I_F=16mA$ | 40 | |
| Turn-Off Time | t_{off} | $R_L=180\Omega$ | 80 | |

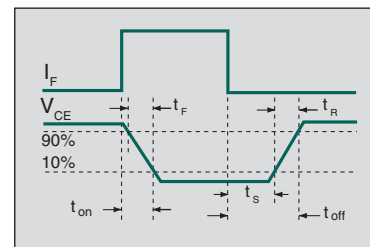

Switching Time Test Circuit

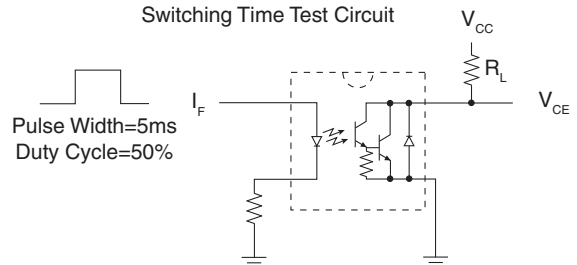

PERFORMANCE DATA*

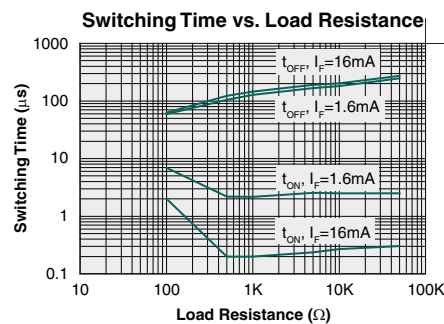
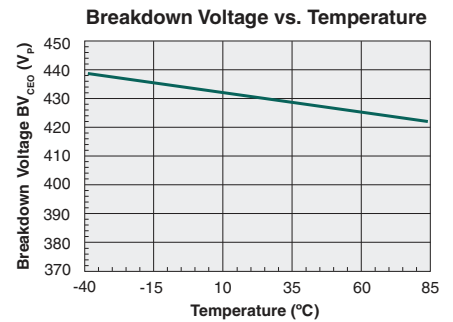
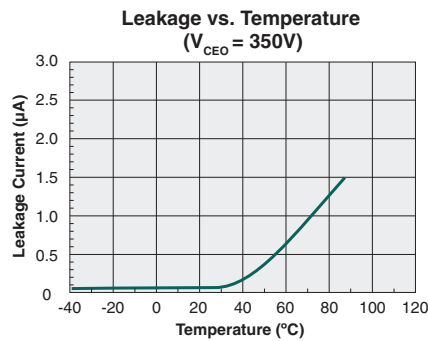
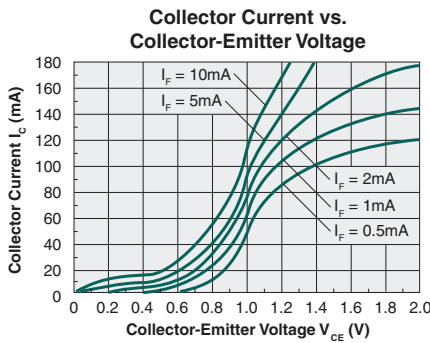
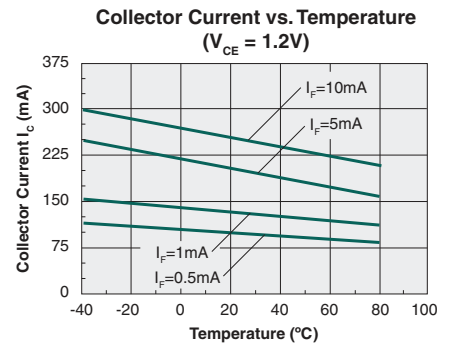
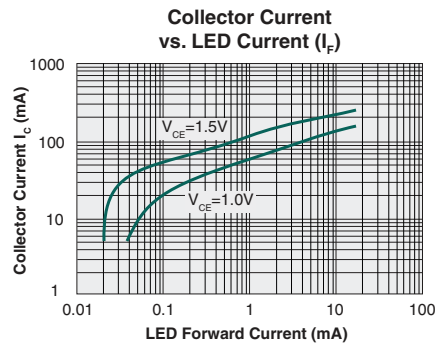
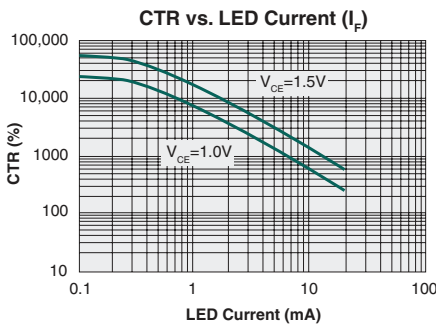
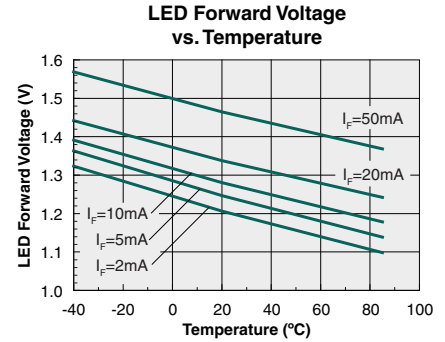
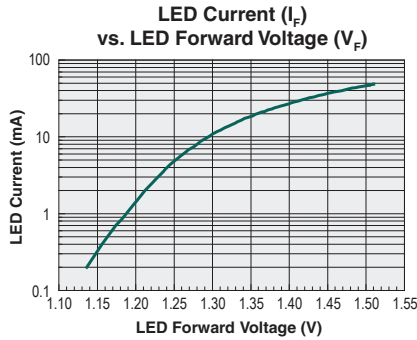
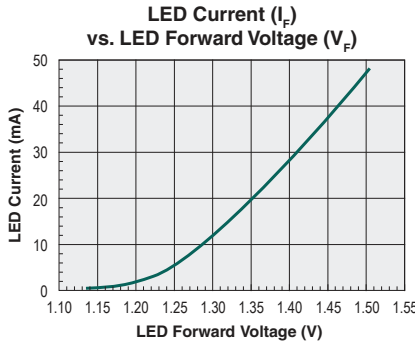

*Unless otherwise noted, data presented in these graphs is typical of device operation at 25°C.
For guaranteed parameters not indicated in the written specifications, please contact our application department.

Manufacturing Information

Moisture Sensitivity



All plastic encapsulated semiconductor packages are susceptible to moisture ingress. IXYS Integrated Circuits classifies its plastic encapsulated devices for moisture sensitivity according to the latest version of the joint industry standard, **IPC/JEDEC J-STD-020**, in force at the time of product evaluation. We test all of our products to the maximum conditions set forth in the standard, and guarantee proper operation of our devices when handled according to the limitations and information in that standard as well as to any limitations set forth in the information or standards referenced below.

Failure to adhere to the warnings or limitations as established by the listed specifications could result in reduced product performance, reduction of operable life, and/or reduction of overall reliability.

This product carries a Moisture Sensitivity Level (MSL) classification as shown below, and should be handled according to the requirements of the latest version of the joint industry standard **IPC/JEDEC J-STD-033**.

| Device | Moisture Sensitivity Level (MSL) Classification |
|-----------|---|
| CPC1301G | MSL 1 |
| CPC1301GR | MSL 3 |

ESD Sensitivity



This product is **ESD Sensitive**, and should be handled according to the industry standard **JESD-625**.

Soldering Profile

Provided in the table below is the Classification Temperature (T_c) of this product and the maximum dwell time the body temperature of this device may be above ($T_c - 5$)°C. The classification temperature sets the Maximum Body Temperature allowed for this device during lead-free reflow processes. Additionally, for the CPC1301GR, the solder reflow profile given in Technical Brief TB-200 "**Pb-Free Solder Reflow Profile for Select Devices**" must be followed. For the through-hole device, CPC1301G, and any other processes, the guidelines of **J-STD-020** must be observed.

| Device | Classification Temperature (T_c) | Dwell Time (t_p) | Max Reflow Cycles |
|-----------|--------------------------------------|----------------------|-------------------|
| CPC1301G | 250°C | 15 seconds | 1 |
| CPC1301GR | 250°C | 15 seconds | 3 |

Board Wash

IXYS Integrated Circuits recommends the use of no-clean flux formulations. Board washing to reduce or remove flux residue following the solder reflow process is acceptable provided proper precautions are taken to prevent damage to the device. These precautions include, but are not limited to: using a low pressure wash and providing a follow up bake cycle sufficient to remove any moisture trapped within the device due to the washing process. Due to the variability of the wash parameters used to clean the board, determination of the bake temperature and duration necessary to remove the moisture trapped within the package is the responsibility of the user (assembler). Cleaning or drying methods that employ ultrasonic energy may damage the device and should not be used. Additionally, the device must not be exposed to flux or solvents that are Chlorine- or Fluorine-based.



MECHANICAL DIMENSIONS

CPC1301G

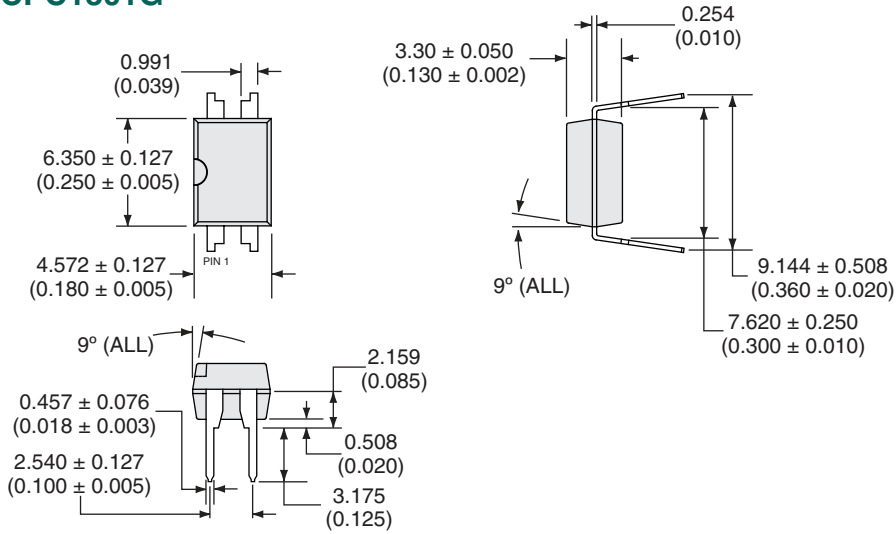

PC Board Pattern (Top View)

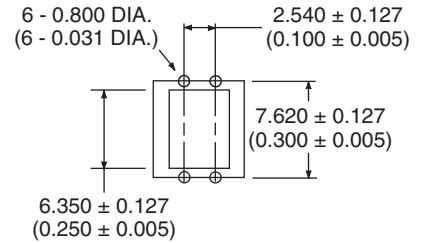

Dimensions
mm
(inches)

CPC1301GR

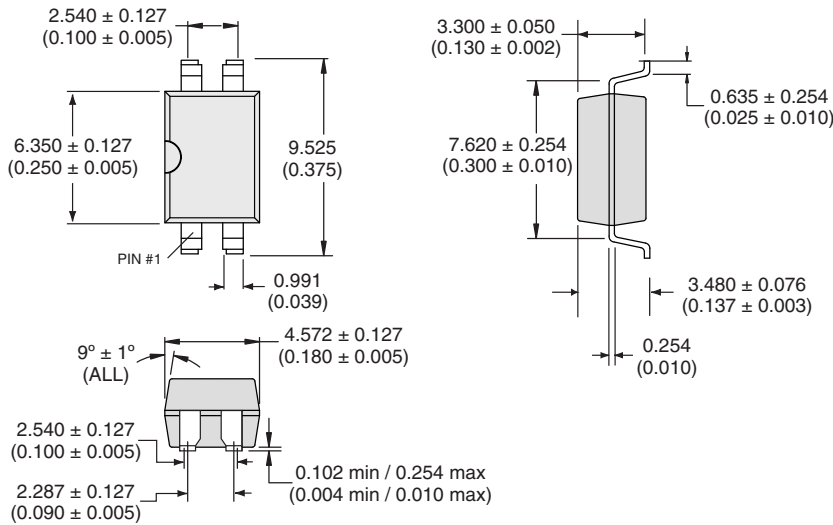

PCB Land Pattern

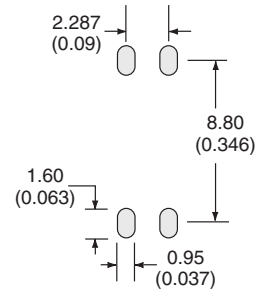

Dimensions
mm
(inches)

CPC1301GRTR Tape & Reel

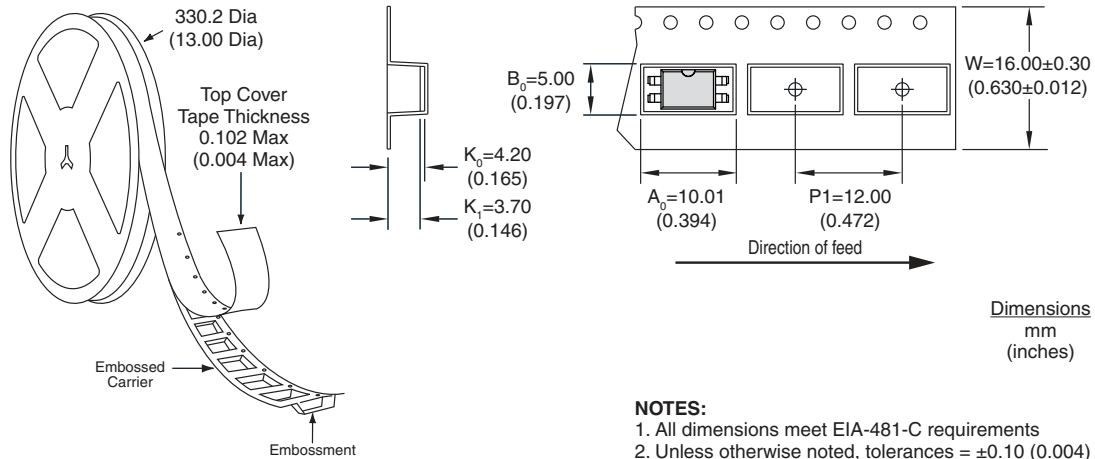

- NOTES:**
1. All dimensions meet EIA-481-C requirements
 2. Unless otherwise noted, tolerances = ± 0.10 (0.004)

For additional information please visit our website at: www.ixysic.com

IXYS Integrated Circuits makes no representations or warranties with respect to the accuracy or completeness of the contents of this publication and reserves the right to make changes to specifications and product descriptions at any time without notice. Neither circuit patent licenses nor indemnity are expressed or implied. Except as set forth in IXYS Integrated Circuits' Standard Terms and Conditions of Sale, IXYS Integrated Circuits assumes no liability whatsoever, and disclaims any express or implied warranty, relating to its products including, but not limited to, the implied warranty of merchantability, fitness for a particular purpose, or infringement of any intellectual property right.

The products described in this document are not designed, intended, authorized or warranted for use as components in systems intended for surgical implant into the body, or in other applications intended to support or sustain life, or where malfunction of IXYS Integrated Circuits' product may result in direct physical harm, injury, or death to a person or severe property or environmental damage. IXYS Integrated Circuits reserves the right to discontinue or make changes to its products at any time without notice.