

Mounting Dimensions (For Reference Only)

**AML11/12 and 21/22 SWITCHES
AML41C/D and AML42C INDICATORS**

Note: Top of full guard bezel housing .19/5,0 from panel.

PUSHBUTTONS

For terminal locations, see page 61.

AML27 SWITCHES

KEYLOCK

For terminal locations, see page 62.

AML14/16 and AML24/26 SWITCHES

ROCKERS

For terminal locations, see page 61, 62.

AML13/15 and 23/25 SWITCHES

PADDLES

LED Location Same as Rocker

For terminal locations, see page 61, 62.

**AML41 INDICATOR
LENS STYLE**

**AML42 INDICATOR
MINIATURE**

For terminal locations, see page 62.

NOTE
1 Dimensions are mm or mm/IN
IN

TERMINAL TYPES

Solder Hole will accept two #22 AWG Stranded Conductor (per NEMA publication DC-2 1976)

Manuals

Manual Switches

Mounting Dimensions (For Reference Only)

AML Series

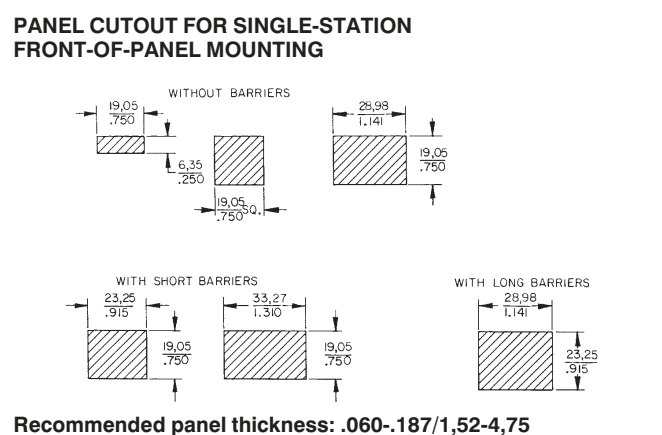
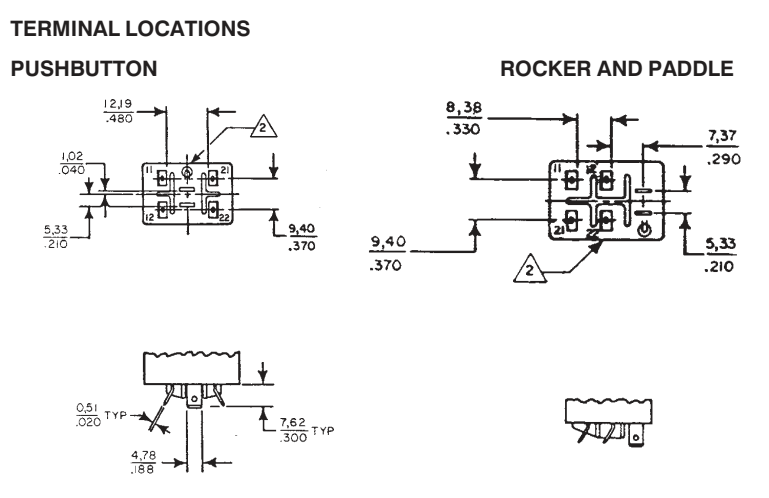
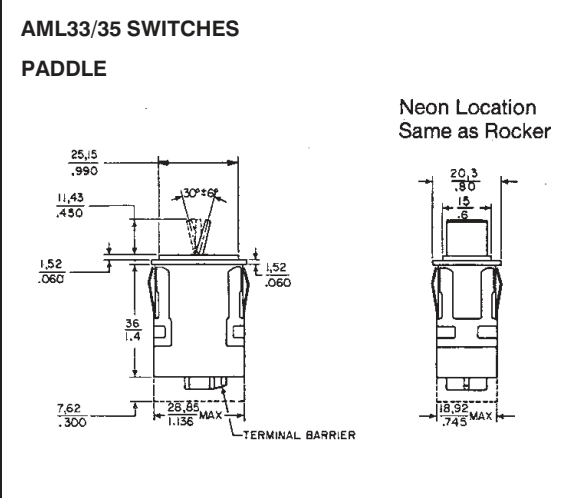
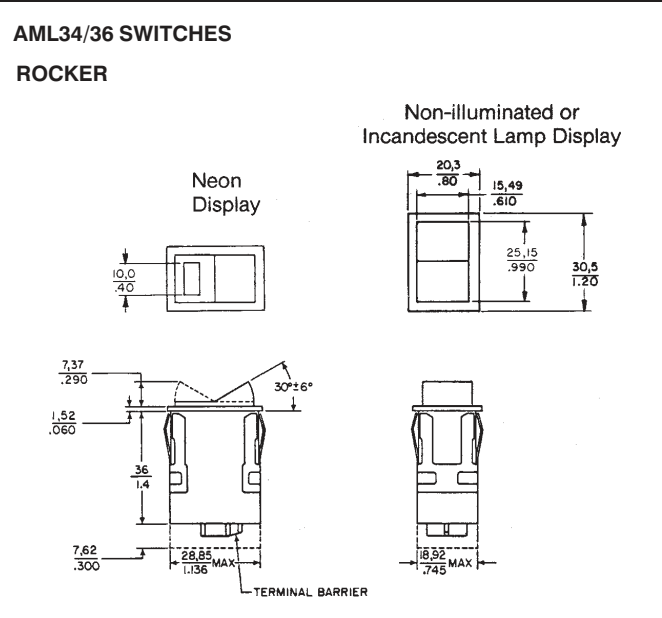
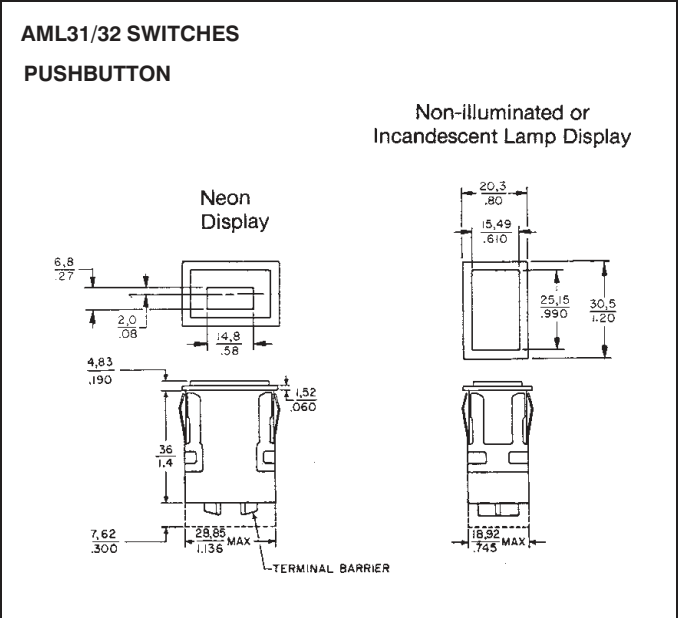

NOTES
 1 Dimensions are mm or mm/IN
 IN
 Manufacturers logo on this side of housing
 Solder Hole Will Accept One #14 AWG Stranded Conductor
 (Per NEMA Publication DC-2 1976)

PANEL PUNCH FOR AML SERIES
 A panel punch is manufactured by Greenlee-Textron Tool Co.,
 Rockford, IL (815-926-3011).

Manual Switches

Mounting Dimensions (For Reference Only)

AML Series

TERMINAL LOCATIONS FOR AML10 SWITCHES

PUSHBUTTONS

Solder and Quick-Connect

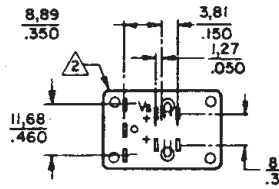
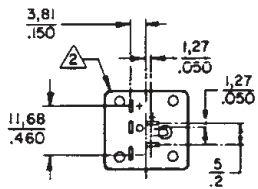

Printed Circuit

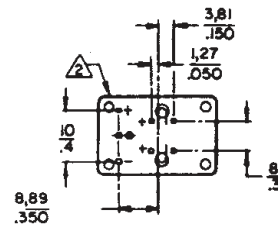
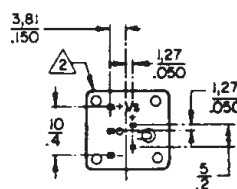

Illuminated devices shown (non-illuminated devices do not have lamp terminals).

ROCKERS AND PADDLES

Solder and Quick-Connect

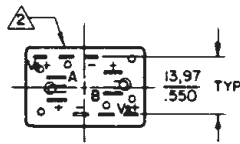
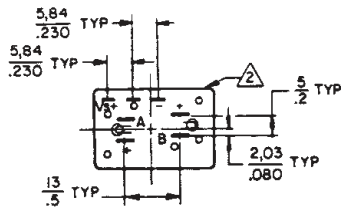

Printed Circuit

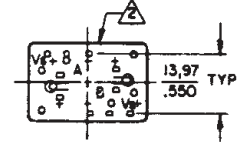
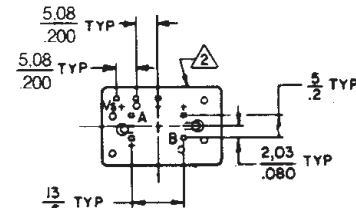

One Integrated Circuit

Two Integrated Circuits

One Integrated Circuit

Two Integrated Circuits

Illuminated devices shown (non-illuminated devices do not have lamp terminals)

TERMINAL LOCATIONS FOR AML41 INDICATORS

Solder and Quick-Connect

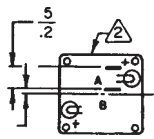

1 Incandescent Lamp Circuit

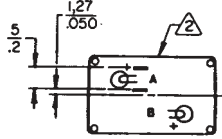

1 Incandescent Lamp Circuit

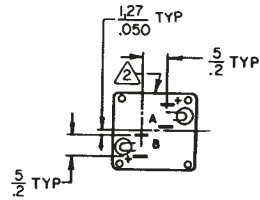

2 Incandescent Lamp Circuits

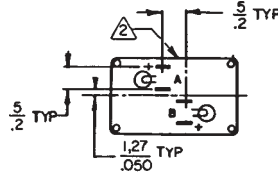

2 Incandescent Lamp Circuits

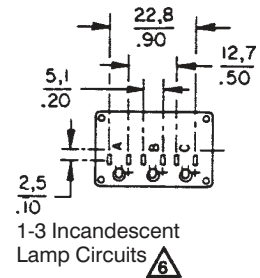

1-3 Incandescent Lamp Circuits

Printed Circuit

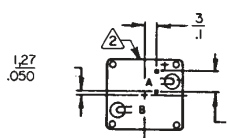

1 Incandescent Lamp Circuit

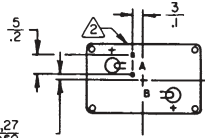

1 Incandescent Lamp Circuit

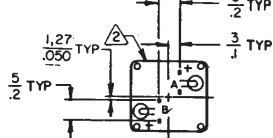

2 Incandescent Lamp Circuits

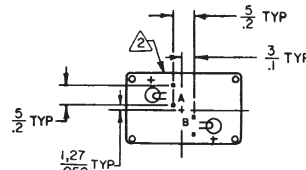

2 Incandescent Lamp Circuits

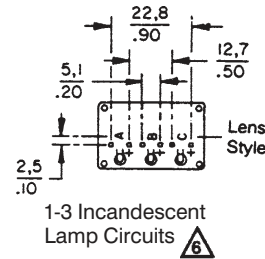

1-3 Incandescent Lamp Circuits

TERMINAL LOCATIONS FOR AML42 INDICATORS

Solder and Quick-Connect

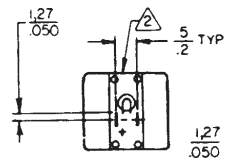

1 LED Circuit

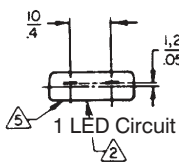

1 LED Circuit

Printed Circuit

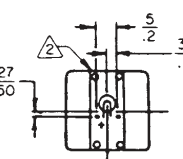

1 LED Circuit

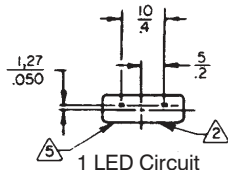

1 LED Circuit

NOTE

1 Dimensions are **MM** or **MM/IN**

2 Manufacturer's logo on this side of housing

4 - Lamp terminals are not provided for non-illuminated devices

5 positive terminal ident. (+) marked this side of housing

6 1 - lamp termination identified by "B".
2 - lamp termination identified by "A" and "C".

Manuals

Manual Switches

Mounting Dimensions (For Reference Only)

AML Series

TERMINAL LOCATIONS FOR AML20 SWITCHES

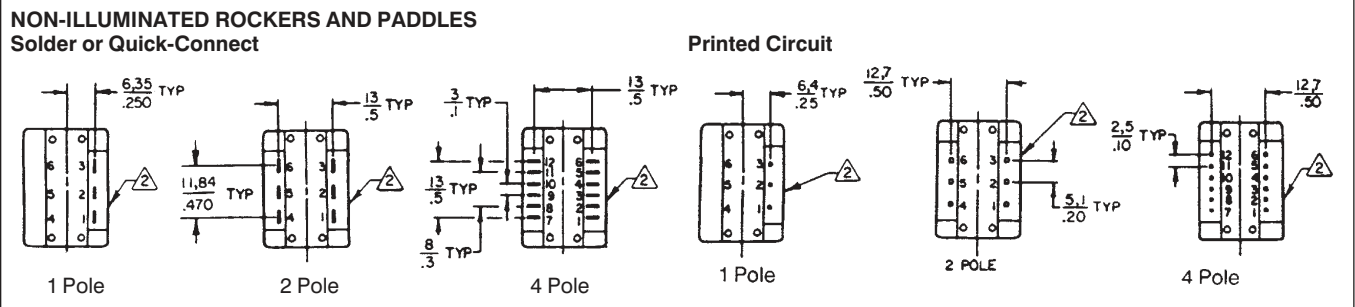
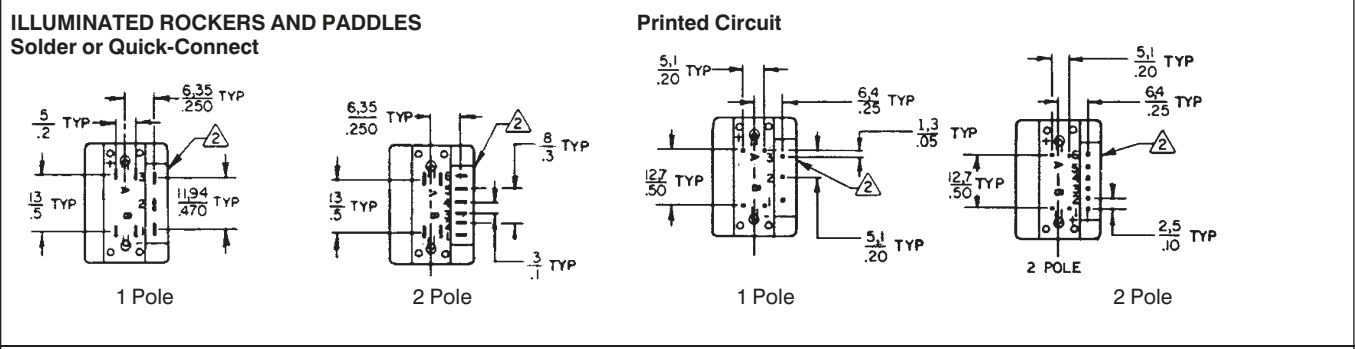
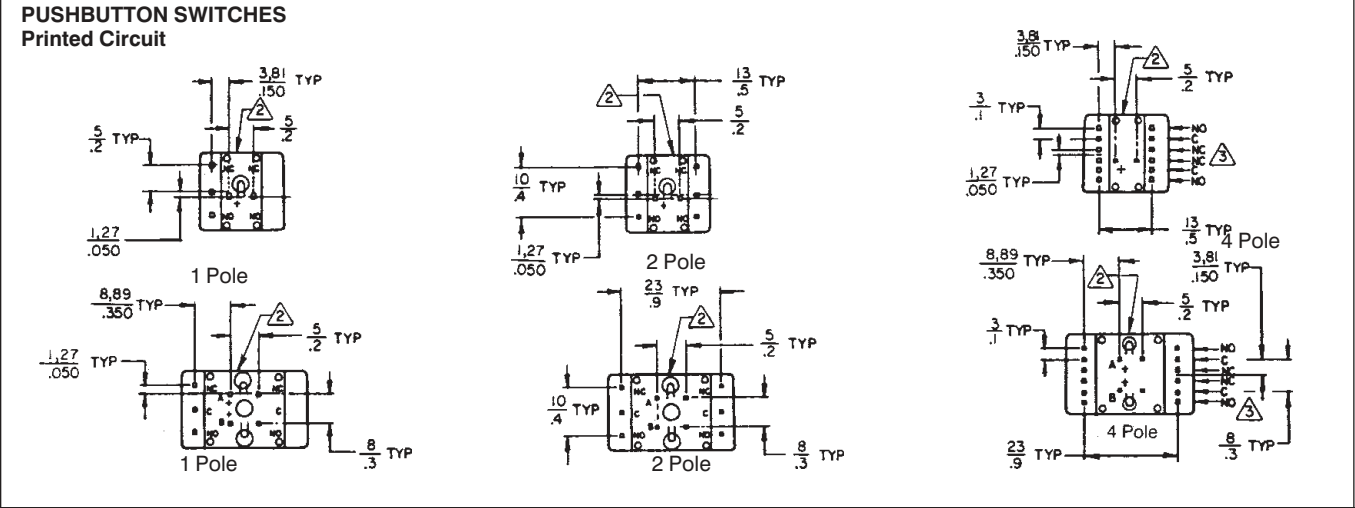
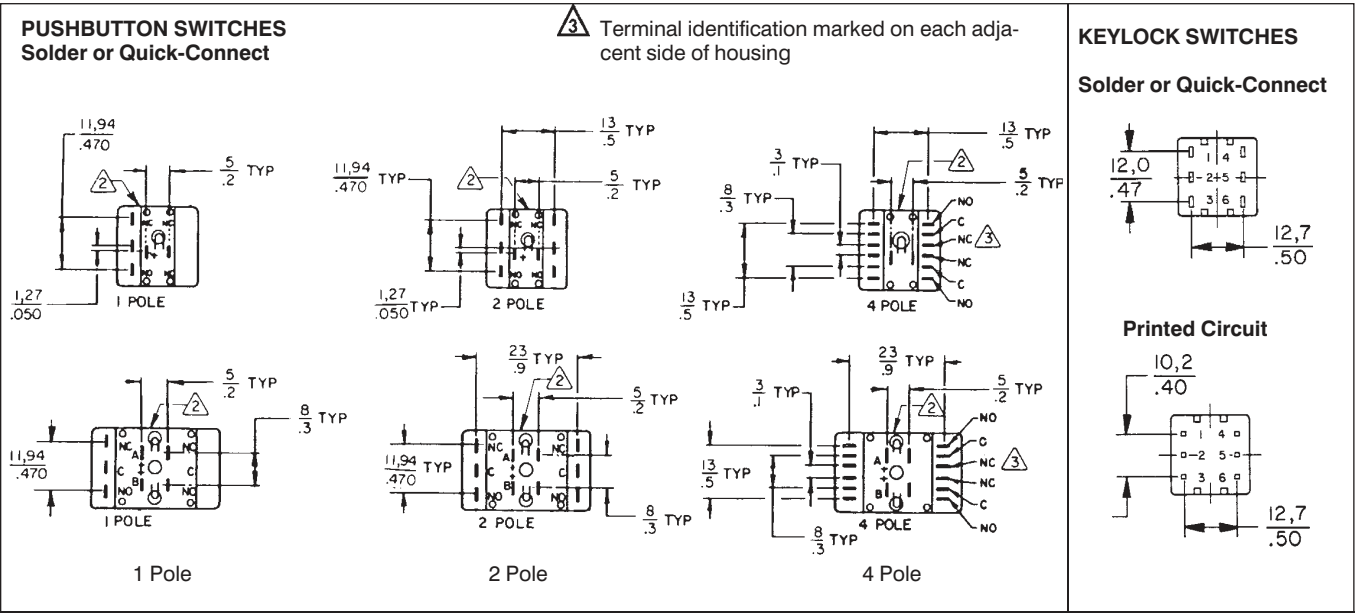

Manual Switches

Mounting Dimensions (For Reference Only)

AML Series

ANNUNCIATORS

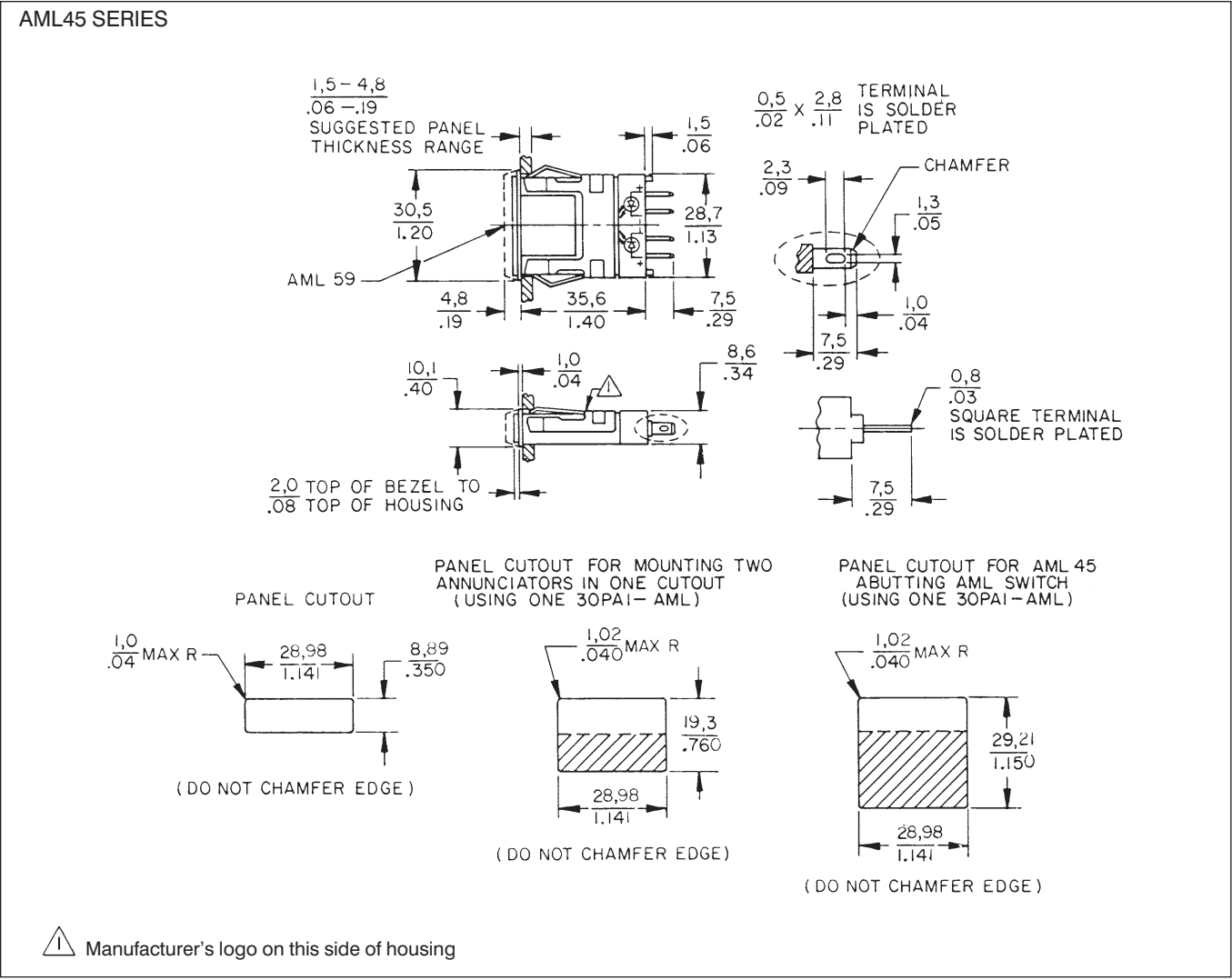

Manuals

For panel punch manufacturer, see page 60.

Manual Switches

Mounting Dimensions (For Reference Only)

MULTI-STATION FRONT-PANEL MOUNTING

Panel cutouts (See page 61 for panel punch manufacturer.)

Square Switches & Indicators	Rect. Switches & Indicators	Annunciator
(.8) (No. of units) — .045*	(1.20) (No. of units) — .045*	(.40) (No. of units) — .045*
(20,3) (No. of units) — 1,14*	(30,5) (No. of units) — 1,14*	(10,1) (No. of units) — 1,14*

For each barrier, add .053/1,35

* Note: If barriers are used, do not subtract .045 in./1,14 mm from the panel cutout formula. (.045 in./1,14mm is the allowance for the width of the bezel.)

AML61 MULTI-STATION SUBPANEL MOUNTING

Panel cutouts for AML61

Mounting Bracket Orientation	Width	Length
A*	in. .810 mm 20,57	(.810)(No. of units)
B	in. .810 mm 20,57	(1.210)(No. of units)
C or D*	in. 1.210 mm 27,94	(.810)(No. of units)

* More than two cans with mounting brackets required for strips of more than 10 units.

AML61 MOUNTING CENTERS

Mounting Bracket Orientation		Mounting Centers/Number of Cans											
		1	2	3	4	5	6	7	8	9	10	11	12
"A" or "C"	in.	1.285	2.095	2.905	3.715	4.525	5.335	6.145	6.955	7.765	8.575	9.385	10.195
	mm	32,64	53,21	73,79	94,36	114,94	135,51	156,08	176,66	197,23	217,81	238,38	258,95
"B"	in.	1.685	2.895	4.105	5.315	6.525	7.735	8.945	10.155				
	mm	42,80	73,53	104,27	135,00	165,74	196,48	227,20	257,94				
"D" or "E"	in.	on C _L	.807	1.614	2.421	3.228	4.035	4.842	5.649	6.456	7.263	8.070	8.877
	mm	on C _L	20,50	41,00	61,49	81,99	102,49	122,99	143,48	163,98	184,48	204,98	225,48

Tolerance = ±.015

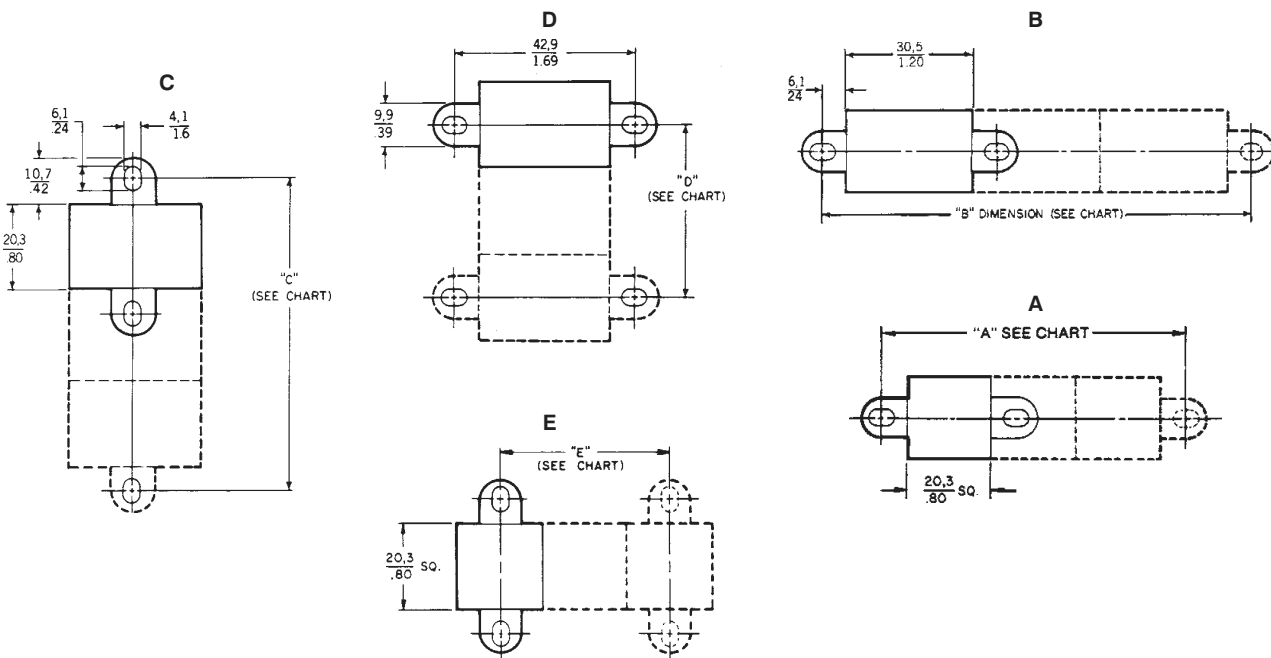

Manual Switches

Mounting Dimensions (For Reference Only)

AML75 PANEL SEAL ACCESSORY

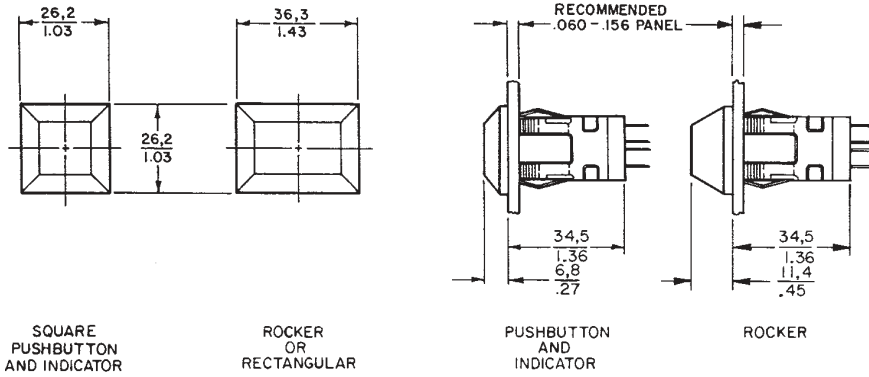

Panel cutouts

Multiple panel sealed units should not be mounted together in a single elongated slot, since this would create an unsealed space between each unit.

Side-by-side mounting can be achieved, per the center-to-center dimensions shown in the drawing. (Dotted lines indicate the seal bases which are abutting at front of panel.)

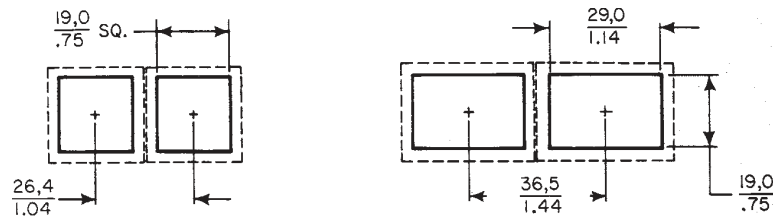

NOTE: Suggested cutout dimensions are based on an .125"/3,18 mm panel thickness. Individual preferences for inpanel fit

may require measurement of assemblies before panels are cut.

AML75 seals are not designed for use with the AML61 mounting system.

AML76 SWITCH GUARD ACCESSORY

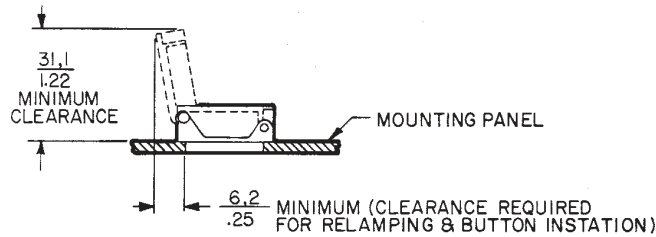
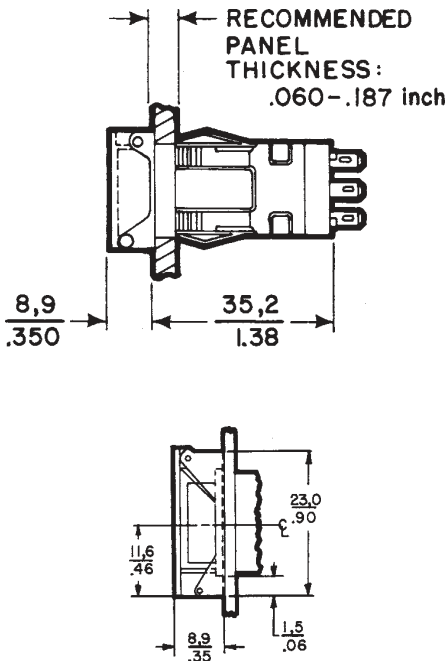

PANEL CUTOUTS

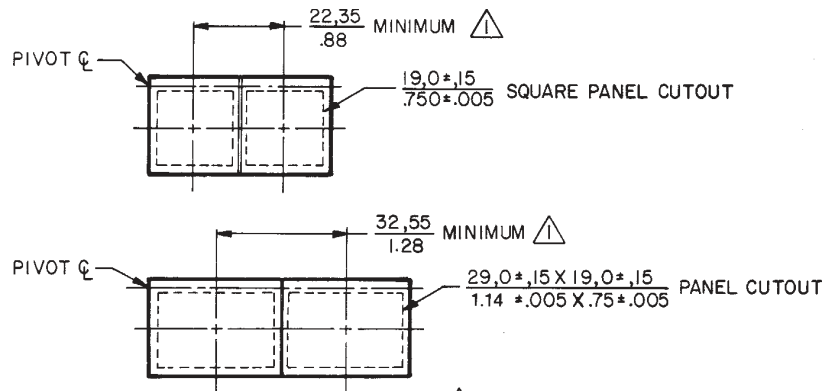

△ MINIMUM DIMENSION ALLOWED FOR MOUNTING GUARDS SIDE BY SIDE