

PART NUMBER	REVISION	DESCRIPTION	FEED TYPE
2151099-1	U	FINE CRIMP HEIGHT ADJUST	MECHANICAL
2151099-2	U	FINE CRIMP HEIGHT ADJUST	PNEUMATIC
7-2151099-1	U	MECHANICAL AND CRIMP TOOLING KIT	MECHANICAL
7-2151099-2	U	PNEUMATIC AND CRIMP TOOLING KIT	PNEUMATIC
7-2151099-7	T	CRIMP TOOLING KIT	-

ATLANTIC VERSION TERMINATOR INTERFACE ADAPTER



APPLICATOR DATA		
CRIMP	SIZE	TYPE
WIRE	2.03 mm [.080]	F
INSUL	2.55 mm [.100]	OV

APPLICATOR INSTRUCTIONS 408-35042

TERMINAL DATA: TE TERMINAL		TE CRIMP SPECIFICATION	
TERMINAL NAME: JUNIOR-POWER-TIMER CONTACT			
WIRE STRIP LENGTH	INSULATION DIAMETER RANGE		
3.70-4.30 mm [.146-.169 IN]	Ø1.40-2.10 mm [.055-.083 IN]		
TERMINAL APPLICATION SPECIFICATION	(A) 114-18050		
	(B) 114-18051		
TERMINALS APPLIED			
TE TERMINAL	TE TERMINAL	TE TERMINAL	TE TERMINAL
(A) 964284-1	(A) 1-964284-1	(B) 1-964294-3	
(A) 964284-2	(A) 2-964284-1	(B) 2-964294-1	
(A) 964284-6	(A) 4-964284-1	(B) 2-964294-2	

TERMINAL DATA: TE TERMINAL		TE CRIMP SPECIFICATION	
TERMINAL NAME: JUNIOR-POWER-TIMER CONTACT			
WIRE STRIP LENGTH	INSULATION DIAMETER RANGE		
3.50-4.10mm [.138-.161 IN]	Ø1.40-2.10 mm [.055-.083 IN]		
TERMINAL APPLICATION SPECIFICATION	114-18387		
TERMINALS APPLIED			
TE TERMINAL	TE TERMINAL	TE TERMINAL	TE TERMINAL
1241388-1			
1241388-2			
1241388-3			

WIRE SIZE	CRIMP HEIGHT mm [INCH]	CRIMP HEIGHT REFERENCE SETTING
1.00mm2	1.20+/-0.05 [.047+/- .002]	5.5
0.75mm2	1.18+/-0.05 [.046+/- .002]	5.7
0.50mm2	1.15+/-0.05 [.045+/- .002]	5.8

WIRE SIZE	CRIMP HEIGHT mm [INCH]	CRIMP HEIGHT REFERENCE SETTING
1.00mm2	1.20+/-0.05 [.047+/- .002]	5.5
0.75mm2	1.18+/-0.05 [.046+/- .002]	5.7
0.50mm2	1.15+/-0.05 [.045+/- .002]	5.8

TERMINAL DATA: TE TERMINAL		TE CRIMP SPECIFICATION	
TERMINAL NAME: JUNIOR-POWER-TIMER CONTACT			
WIRE STRIP LENGTH	INSULATION DIAMETER RANGE		
3.70-4.30mm [.138-.161 IN]	Ø1.40-2.10 mm [.055-.083 IN]		
TERMINALS APPLIED			
TE TERMINAL	TE TERMINAL	TE TERMINAL	TE TERMINAL
964284-2			
964284-6			
2-964284-1			

WIRE SIZE	CRIMP HEIGHT mm [INCH]	CRIMP HEIGHT REFERENCE SETTING
0.35 + 0.75	1.27+/-0.05 [.050+/- .002]	5.7
0.5+0.5mm2	1.22+/-0.05 [.048+/- .002]	5.3
0.35+0.35mm2	1.18+/-0.05 [.046+/- .002]	5.7

TERMINAL DATA: TE TERMINAL		TE CRIMP SPECIFICATION	
TERMINAL NAME: JUNIOR-POWER-TIMER CONTACT			
WIRE STRIP LENGTH	INSULATION DIAMETER RANGE		
3.50-4.10mm [.138-.161 IN]	Ø1.40-2.10 mm [.055-.083 IN]		
TERMINALS APPLIED			
TE TERMINAL	TE TERMINAL	TE TERMINAL	TE TERMINAL
1241388-1			
1241388-2			
1241388-3			

WIRE SIZE	CRIMP HEIGHT mm [INCH]	CRIMP HEIGHT REFERENCE SETTING
0.5+0.5mm2	1.22+/-0.05 [.048+/- .002]	5.3
0.50 + 0.35mm2	1.19+/-0.05 [.047+/- .002]	6.0
0.35+0.35mm2	1.18+/-0.05 [.046+/- .002]	5.7

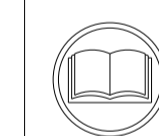

- 1. RECOMMENDED SPARE PARTS
- 2. REFER TO SUPPLIED INSTRUCTION SHEET FOR CLEANING, LUBRICATION, & STORAGE OF APPLICATOR.
- 3. APPLY PART NUMBER 2-23419-6 LOCTITE TO THREADS OF ITEM 242.
- 4. CRIMP HEIGHT REFERENCE SETTING WAS THE SETTING USED WHEN THE APPLICATOR WAS QUALIFIED AT THE FACTORY. ADJUSTMENT MAY BE NECESSARY WHEN RUNNING APPLICATOR IN THE FIELD.
- 5. THIS CRIMP PARAMETER IS PROVIDED TO MEET A CUSTOM AND UNIQUE CUSTOMER REQUIREMENT. IT HAS BEEN EVALUATED AND IS CONDITIONALLY SPECIFIED BY TE CONNECTIVITY. THIS CUSTOMIZED CRIMP PARAMETER IS NOT LISTED AS AN APPROVED APPLICATION WITHIN A TE CONNECTIVITY APPLICATION SPECIFICATION; HOWEVER, IT HAS BEEN VALIDATED ACCORDING TO TE CONNECTIVITY SPECIFICATIONS 109-18079(TEST GROUP 1) AND 114-18022. **TE CONNECTIVITY EXPRESSLY DISCLAIMS ANY AND ALL WARRANTIES THAT THE PRODUCT WILL PERFORM SIMILARLY TO VALIDATED AND APPROVED APPLICATIONS, AS STATED WITHIN TE CONNECTIVITY APPLICATION SPECIFICATIONS, INCLUDING BUT NOT LIMITED TO IMPLIED WARRANTIES OF MERCHANTABILITY OR FITNESS FOR PARTICULAR PURPOSE.** AS SUCH, IT IS HIGHLY RECOMMENDED THAT THE CUSTOMER PERFORM FURTHER DETAILED EVALUATION TO ASSESS PRODUCT PERFORMANCE IN THE SPECIFIC APPLICATION.
- 6. TERMINAL LUBRICANT IS RECOMMENDED.
- 7. UNLESS SPECIFIED OTHERWISE TORQUE VALUES SHALL BE USED PER DOCUMENT, 101-35000.
- 8. WHEN RUNNING WIRE TYPES OTHER THAN WHAT IS LISTED IN THE APPLICATION SPECIFICATION, REFER TO NOTE 5.

***WARNING**
ON INSTALLATION, SET WIRE DISC TO CRIMP HEIGHT REFERENCE SETTING FOR LARGEST WIRE SIZE. CRIMP HEIGHT REFERENCE SETTINGS GREATER THAN THE VALUE SHOWN MAY CAUSE DAMAGE TO THE CRIMP TOOLING. REFER TO THE INSTRUCTION SHEET FOR PROPER SETUP AND ADJUSTMENTS.

ATLANTIC VERSION
Shown on sheets 1 of 4 & 2 of 4
(Pacific version shown on sheets 3 of 4 & 4 of 4)

LOC	DIST	REVISIONS					
A	66	P	LYN	DESCRIPTION	DATE	DWN	APVD
		U		ECR-22-128525	02FEB2022	JWC	TE
		U1		ECR-22-147819	29JUL2022	FZ	YY

-	1	-	1	-	2119641-1	FEED CAM, AIR FEED	248
-	1	1	1	1	2119082-4	CAM, SNAIL, INSULATION ADJUSTMENT	244
-	1	1	1	1	2079764-1	WASHER, WAVE SPRING, CREST-TO-CREST	243
-	1	1	1	1	2119083-1	RETAINER, INSULATION DIAL	242
-	1	1	1	1	7-18023-7	SCR, SKT HD CAP M3 X 4.0	241
-	-	1	-	1	2119580-1	MECHANICAL FEED ASSEMBLY	239
-	1	-	1	-	2844940-1	AIR FEED MODULE	238
-	REF	REF	REF	REF	994970-2	COUNTER, MAGNETIC	164
-	1	1	1	1	2119955-1	ASSY, LUBRICATOR, SIDE FEED	113
-	1	1	1	1	2844908-1	SCREW, LOCKING	99
-	1	1	1	1	2844907-1	POST, LOCKING	98
-	1	1	1	1	455888-5	SPACER, CRIMPER	82
-	1	1	1	1	1803607-3	DOCUMENTATION PACKAGE	71
-	1	1	1	1	1803948-5	DEPRESSOR, WIRE, SPECIAL -	70
-	1	1	1	1	2119740-1	TAG, IDENTIFICATION	67
-	2	2	2	2	2168078-1	SCREW, DRIVE, RH, RoHS, 2 x .188	66
-	1	1	1	1	2168083-2	SCR, SKT HD CAP, RoHS, M4 X 8.0	60
-	1	1	1	1	5-18022-5	SCR, HEX HD CAP, M4 X 6.0	59
-	1	1	1	1	1338685-1	PAWL, FEED	56
-	4	4	4	4	2168083-3	SCR, SKT HD CAP, RoHS, M4 X 12.0	54
-	2	2	2	2	1-2168083-0	SCR, SKT HD CAP, RoHS, M4 X 10	53
-	1	1	1	1	1803382-6	HOLD DOWN, SPRING LOADED	50
-	1	2	1	2	18023-9	SCR, SKT HD CAP M4 X 6.0	49
-	-	1	-	1	2119652-1	FEED CAM, PRE FEED	48
-	-	1	-	1	2119653-1	FEED CAM, POST FEED	47
-	1	1	1	1	1803583-9	APPLICATOR BASIC ASSEMBLY, SF	46
-	1	1	1	1	1803515-1	RAM ASSEMBLY, SF ATLANTIC	44
-	1	1	1	1	1803602-1	SCR, BHSC, RoHS (M8 X 25)	41
-	1	1	1	1	1-1752356-6	SUPPORT, TERMINAL	34
-	2	2	2	2	2079383-5	SCR, BHSC, RoHS (M4 X 20)	33
-	2	2	2	2	2-2844962-8	SPACER, CYLINDRICAL, STRIP GUIDE	30
-	1	1	1	1	2844992-2	ASSEMBLY, STRIP GUIDE	29
-	1	1	1	1	455888-5	SPACER, CRIMPER	28
-	1	1	1	1	1320928-6	STRIP GUIDE	24
-	1	1	1	1	2168083-2	SCR, SKT HD CAP, RoHS, M4 X 8.0	21
-	2	2	2	2	1-18028-2	WASHER, FLAT, REG M4	20
-	1	1	1	1	2119533-1	STRIPPER, SIDE FEED	19
-	1	1	1	1	2119806-1	INSERT, SHEAR	13
-	1	1	1	1	3-22280-3	SPRING, COMPRESSION	12
-	1	1	1	1	1-356885-4	STOP, SHEAR	11
-	1	1	1	1	2119805-1	SHEAR HOLDER, FRONT	10
-	1	1	1	1	1803095-1	FLOATING SHEAR, FRONT	9
1	2	2	1	1	1333204-2	ANVIL, COMBINATION	8
-	1	1	1	1	2119757-6	DEPRESSOR, SHEAR	5
-	1	1	1	1	238011-4	BLOCK, CRIMPER SPACER	4
1	2	2	1	1	2-1803199-6	CRIMPER, INSULATION OVERLAP PREMIUM	3
1	2	2	1	1	1803125-2	CRIMPER, WIRE	1

DIMENSIONS:		TOLERANCES UNLESS OTHERWISE SPECIFIED:		MATERIAL:		WEIGHT:		SCALE:	
mm	0 PLC ±	1 PLC ±	2 PLC ±	3 PLC ±	4 PLC ±	ANGLES ±	FINISH	Customer Accessible Production Drawing	SCALE 1:2 SHEET 1 OF 4 REV U1

LOC	DIST	REVISIONS			
P	LTN	DESCRIPTION	DATE	OWN	APVD
A	66	SEE SHEET 1	-	-	-

FEED TYPE MECHANICAL

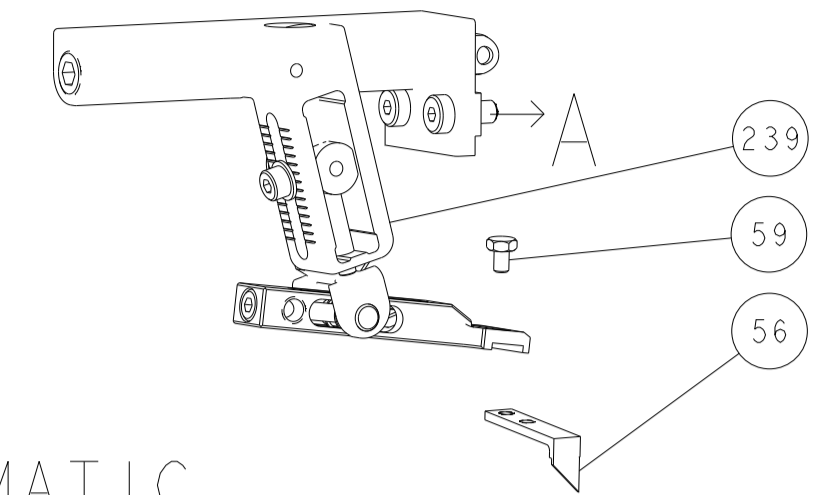

PNEUMATIC

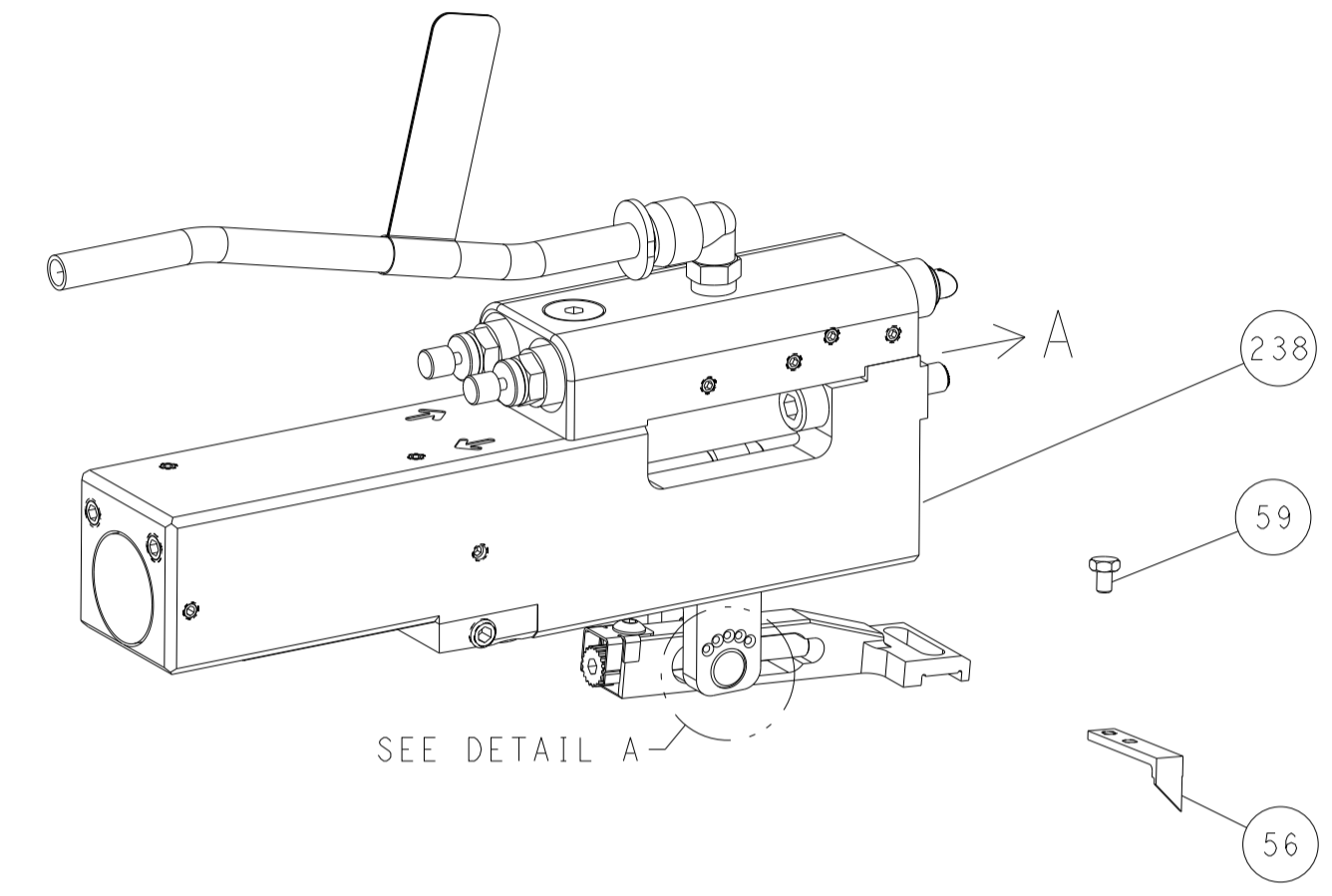

FEED SPRING SETTING POSITION (SHOWN FROM REAR SIDE)

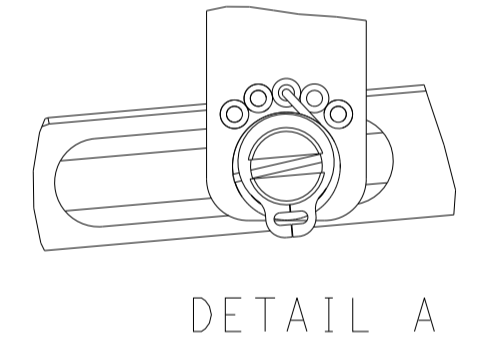

DETAIL A

CAM POSITIONS

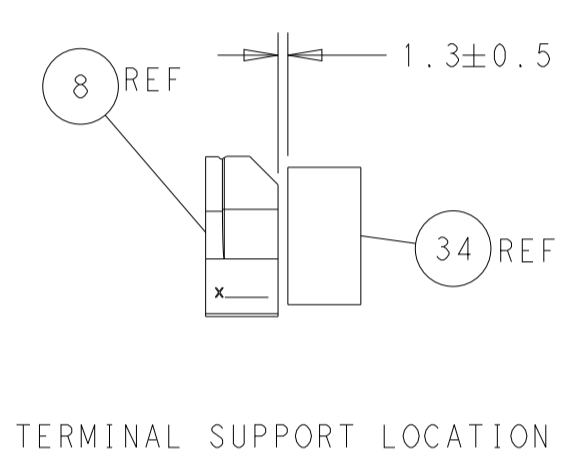
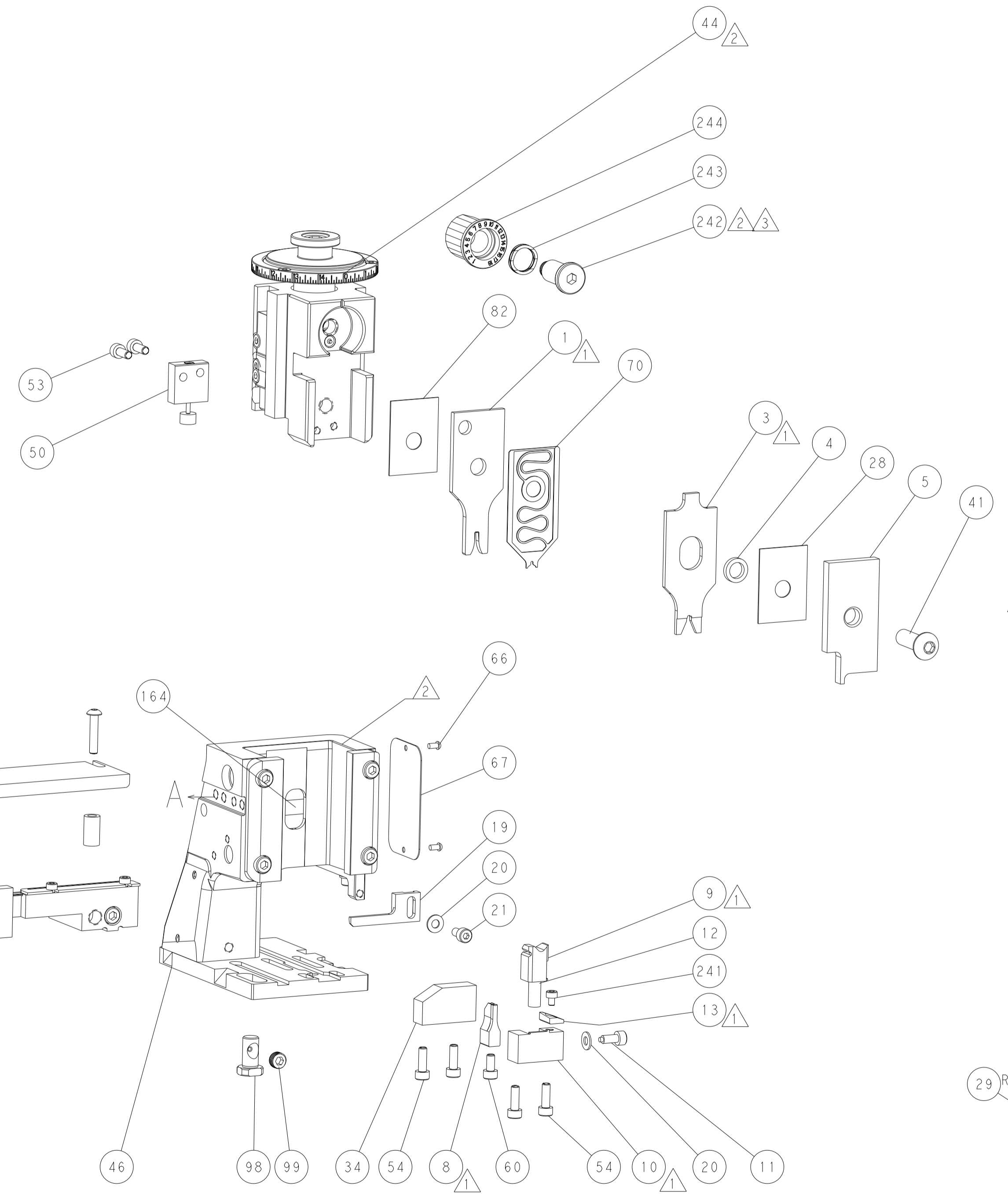
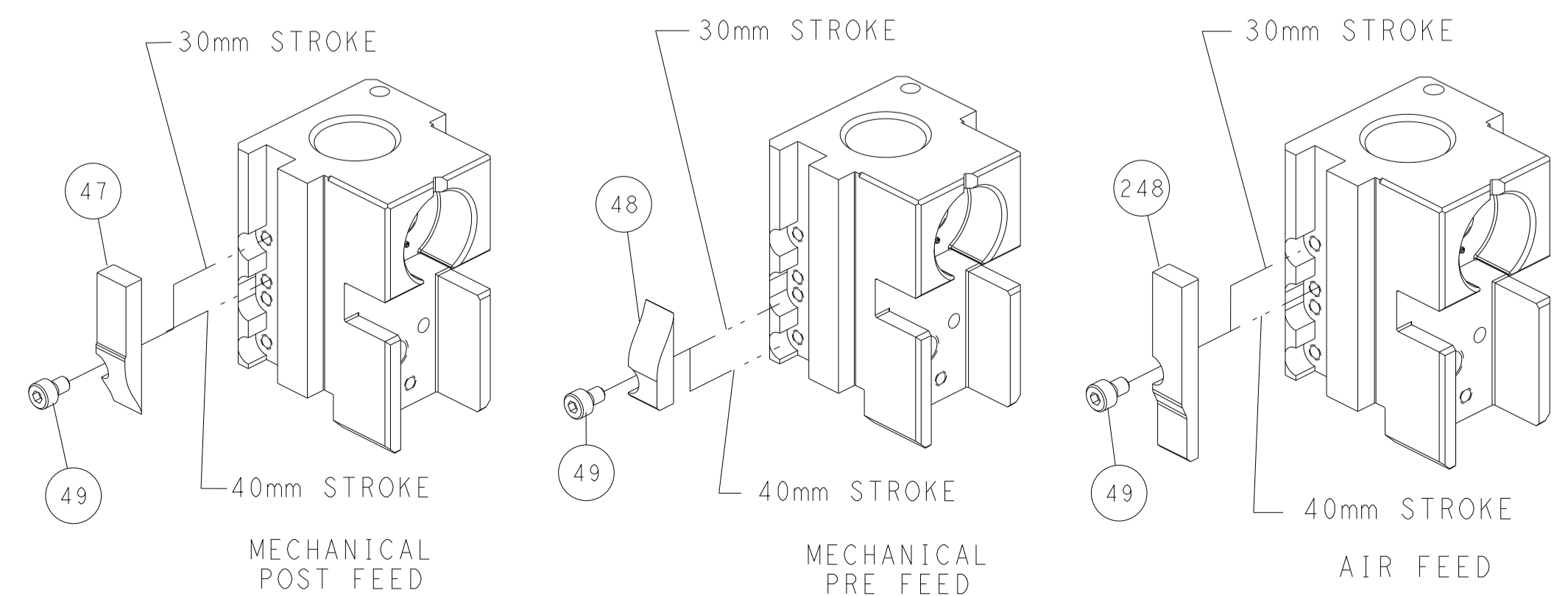

TERMINAL SUPPORT LOCATION

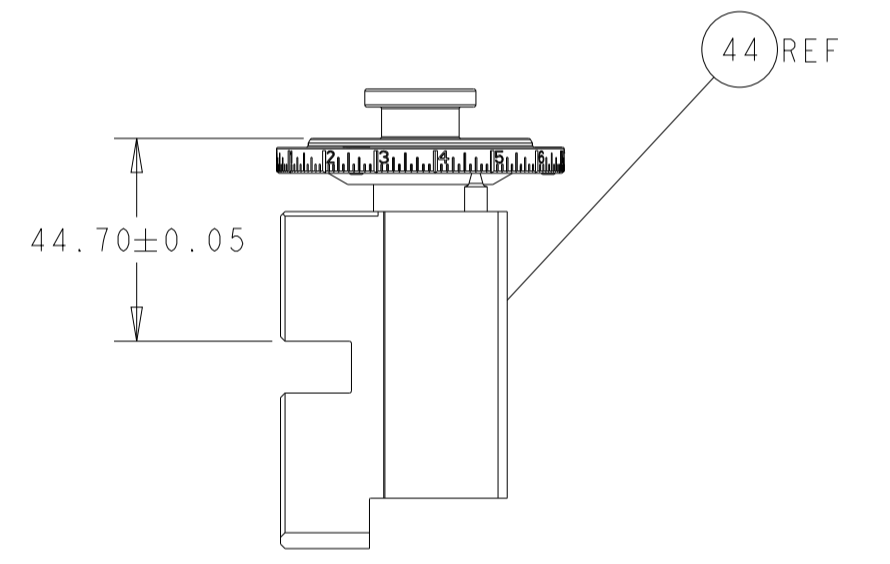

RAM SET-UP

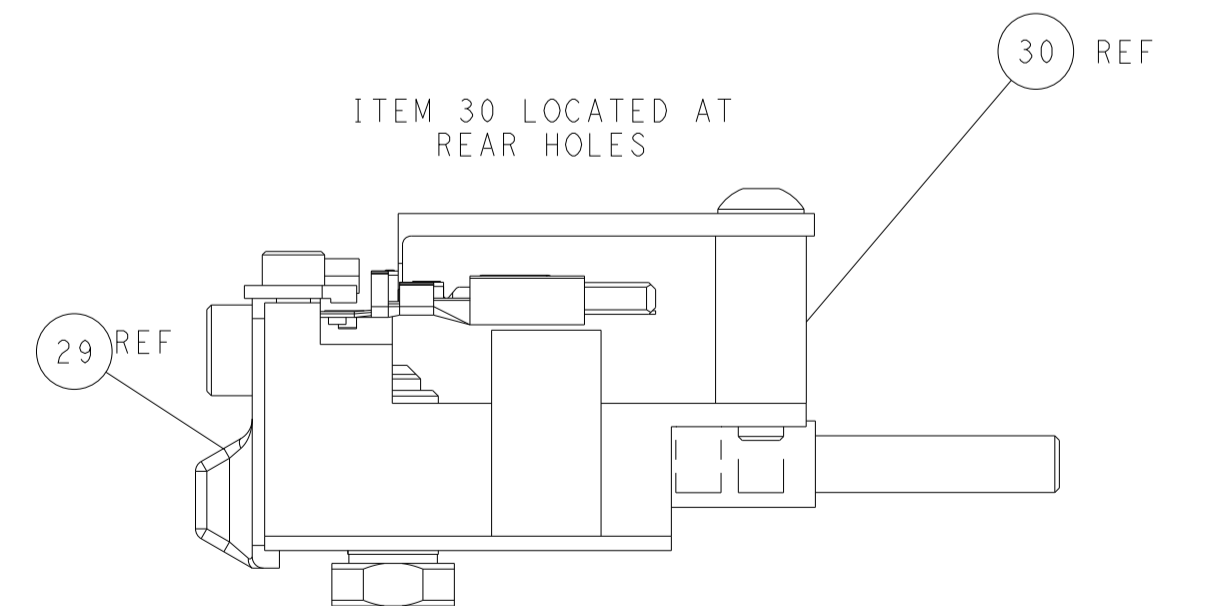

FEED TRACK POSITION GUIDE BY INSULATION BARREL

ATLANTIC VERSION
 Shown on sheets 1 of 4 & 2 of 4
 (Pacific version shown on sheets 3 of 4 & 4 of 4)

DIMENSIONS:		TOLERANCES UNLESS OTHERWISE SPECIFIED:		DRAWING NO		NAME	
mm	0 PLC	±		22AUG2011	TE Connectivity		
	1 PLC	±		22AUG2011	Harrisburg, PA 17105-3608		
	2 PLC	±		S-XI	Ocean Side Feed		
	3 PLC	±		PRODUCT SPEC	Applicator		
	4 PLC	±		APPLICATION SPEC	-		
	ANGLES	±		WEIGHT	SIZE	CAGE CODE	DRAWING NO
	FINISH	±		Customer Accessible Production Drawing	A1	00779	©=2151099
				SCALE	1:2	SHEET	2 of 4
				REV	U1		

PART NUMBER	REVISION	DESCRIPTION	FEED TYPE
2-2151099-1	U	FINE CRIMP HEIGHT ADJUST	MECHANICAL
2-2151099-2	U	FINE CRIMP HEIGHT ADJUST	PNEUMATIC
7-2151099-7	M	CRIMP TOOLING KIT	-

PACIFIC VERSION TERMINATOR
INTERFACE ADAPTER

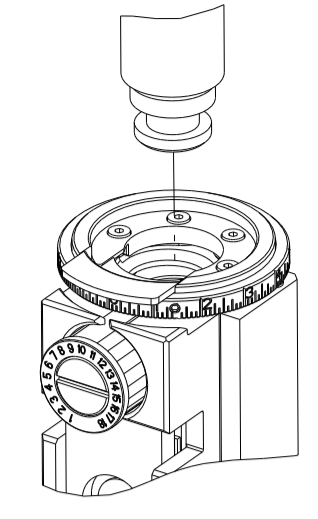

APPLICATOR DATA		
CRIMP	SIZE	TYPE
WIRE	2.03 mm [.080]	F
INSUL	2.55 mm [.100]	OV
APPLICATOR INSTRUCTIONS 408-35042		

TERMINAL DATA: TE TERMINAL		TE CRIMP SPECIFICATION	
TERMINAL NAME: JUNIOR-POWER-TIMER CONTACT			
WIRE STRIP LENGTH	3.70-4.30 mm [.146-.169 IN]	INSULATION DIAMETER RANGE	Ø1.40-2.10 mm [.055-.083 IN]
TERMINAL APPLICATION SPECIFICATION	(A) 114-18050 (B) 114-18051		
TERMINALS APPLIED			
TE TERMINAL	TE TERMINAL	TE TERMINAL	TE TERMINAL
(A) 964284-1	(A) 1-964284-1	(B) 1-964294-3	
(A) 964284-2	(A) 2-964284-1	(B) 2-964294-1	
(A) 964284-6	(A) 4-964284-1	(B) 2-964294-2	

TERMINAL DATA: TE TERMINAL		TE CRIMP SPECIFICATION	
TERMINAL NAME: JUNIOR-POWER-TIMER CONTACT			
WIRE STRIP LENGTH	3.50-4.10mm [.138-.161 IN]	INSULATION DIAMETER RANGE	Ø1.40-2.10 mm [.055-.083 IN]
TERMINAL APPLICATION SPECIFICATION	114-18387		
TERMINALS APPLIED			
TE TERMINAL	TE TERMINAL	TE TERMINAL	TE TERMINAL
1241388-1			
1241388-2			
1241388-3			

WIRE SIZE	CRIMP HEIGHT mm [INCH]	CRIMP HEIGHT REFERENCE SETTING
1.00mm2	1.20+/-0.05 [.047+/- .002]	5.5
0.75mm2	1.18+/-0.05 [.046+/- .002]	5.7
0.50mm2	1.15+/-0.05 [.045+/- .002]	5.8

WIRE SIZE	CRIMP HEIGHT mm [INCH]	CRIMP HEIGHT REFERENCE SETTING
1.00mm2	1.20+/-0.05 [.047+/- .002]	5.5
0.75mm2	1.18+/-0.05 [.046+/- .002]	5.7
0.50mm2	1.15+/-0.05 [.045+/- .002]	5.8

TERMINAL DATA: TE TERMINAL		TE CRIMP SPECIFICATION	
TERMINAL NAME: JUNIOR-POWER-TIMER CONTACT			
WIRE STRIP LENGTH	3.70-4.30mm [.138-.161 IN]	INSULATION DIAMETER RANGE	Ø1.40-2.10 mm [.055-.083 IN]
TERMINAL APPLICATION SPECIFICATION			
TERMINALS APPLIED			
TE TERMINAL	TE TERMINAL	TE TERMINAL	TE TERMINAL
964284-2			
964284-6			
2-964284-1			

WIRE SIZE	CRIMP HEIGHT mm [INCH]	CRIMP HEIGHT REFERENCE SETTING
0.35 + 0.75	1.27+/-0.05 [.050+/- .002]	5.7

TERMINAL DATA: TE TERMINAL		TE CRIMP SPECIFICATION	
TERMINAL NAME: JUNIOR-POWER-TIMER CONTACT			
WIRE STRIP LENGTH	3.50-4.10mm [.138-.161 IN]	INSULATION DIAMETER RANGE	Ø1.40-2.10 mm [.055-.083 IN]
TERMINAL APPLICATION SPECIFICATION			
TERMINALS APPLIED			
TE TERMINAL	TE TERMINAL	TE TERMINAL	TE TERMINAL
1241388-1			
1241388-2			
1241388-3			

WIRE SIZE	CRIMP HEIGHT mm [INCH]	CRIMP HEIGHT REFERENCE SETTING
0.5+0.5mm2	1.22+/-0.05 [.048+/- .002]	5.3
0.50 + 0.35mm2	1.19+/-0.05 [.047+/- .002]	6.0
0.35+0.35mm2	1.18+/-0.05 [.046+/- .002]	5.7

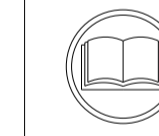

- 1 RECOMMENDED SPARE PARTS
- 2 REFER TO SUPPLIED INSTRUCTION SHEET FOR CLEANING, LUBRICATION, & STORAGE OF APPLICATOR.
- 3 APPLY PART NUMBER 2-23419-6 LOCTITE TO THREADS OF ITEM 242.
- 4 CRIMP HEIGHT REFERENCE SETTING WAS THE SETTING USED WHEN THE APPLICATOR WAS QUALIFIED AT THE FACTORY. ADJUSTMENT MAY BE NECESSARY WHEN RUNNING APPLICATOR IN THE FIELD.
- 5 THIS CRIMP PARAMETER IS PROVIDED TO MEET A CUSTOM AND UNIQUE CUSTOMER REQUIREMENT. IT HAS BEEN EVALUATED AND IS CONDITIONALLY SPECIFIED BY TE CONNECTIVITY. THIS CUSTOMIZED CRIMP PARAMETER IS NOT LISTED AS AN APPROVED APPLICATION WITHIN A TE CONNECTIVITY APPLICATION SPECIFICATION; HOWEVER, IT HAS BEEN VALIDATED ACCORDING TO TE CONNECTIVITY SPECIFICATIONS 109-18079 (TEST GROUP 1) AND 114-18022. **TE CONNECTIVITY EXPRESSLY DISCLAIMS ANY AND ALL WARRANTIES THAT THE PRODUCT WILL PERFORM SIMILARLY TO VALIDATED AND APPROVED APPLICATIONS, AS STATED WITHIN TE CONNECTIVITY APPLICATION SPECIFICATIONS, INCLUDING BUT NOT LIMITED TO IMPLIED WARRANTIES OF MERCHANTABILITY OR FITNESS FOR PARTICULAR PURPOSE.** AS SUCH, IT IS HIGHLY RECOMMENDED THAT THE CUSTOMER PERFORM FURTHER DETAILED EVALUATION TO ASSESS PRODUCT PERFORMANCE IN THE SPECIFIC APPLICATION.
- 6 TERMINAL LUBRICANT IS RECOMMENDED.

- 7. UNLESS SPECIFIED OTHERWISE TORQUE VALUES SHALL BE USED PER DOCUMENT, 101-35000.
- 8. WHEN RUNNING WIRE TYPES OTHER THAN WHAT IS LISTED IN THE APPLICATION SPECIFICATION, REFER TO NOTE 5.

***WARNING**
ON INSTALLATION, SET WIRE DISC TO CRIMP HEIGHT REFERENCE SETTING FOR LARGEST WIRE SIZE. CRIMP HEIGHT REFERENCE SETTINGS GREATER THAN THE VALUE SHOWN MAY CAUSE DAMAGE TO THE CRIMP TOOLING. REFER TO THE INSTRUCTION SHEET FOR PROPER SETUP AND ADJUSTMENTS.

ENTRY LEVEL APPLICATOR		ITEM SUBSTITUTION LIST		
PART NUMBER	SAME AS	ITEM	ITEM DESCRIPTION	SUBSTITUTE PART NUMBER
8-2151099-1	2151099-1	1	WIRE CRIMPER	1803531-2
8-2151099-2	2151099-2	3	INSULATION CRIMPER	2-1803732-6
9-2151099-1	2-2151099-1	46	BASIC SUB -ASSEMBLY	1803940-9
9-2151099-2	2-2151099-2	141	BASIC SUB -ASSEMBLY	1-1803940-0
			LUBRICATOR	DELETE

PACIFIC VERSION
Shown on sheets 3 of 4 & 4 of 4
(Atlantic version shown on sheets 1 of 4 & 2 of 4)

LOC	DIST	REVISIONS			
A	66	P LTR	DESCRIPTION	DATE	OWN
		-	SEE SHEET 1	-	-

-	1	1	2119082-4	CAM, SNAIL, INSULATION ADJUSTMENT	244
-	1	1	2079764-1	WASHER, WAVE SPRING, CREST-TO-CREST	243
-	1	1	2119083-1	RETAINER, INSULATION DIAL	242
-	1	1	7-18023-7	SCR, SKT HD CAP M3 X 4.0	241
-	-	1	2119580-1	MECHANICAL FEED ASSEMBLY	239
-	1	-	2844940-1	AIR FEED MODULE	238
-	REF	REF	994970-2	COUNTER, MAGNETIC	164
-	1	-	2119641-2	FEED CAM, AIR FEED	151
-	1	1	2168083-8	SCR, SKT HD CAP, RoHS, M4 X 16	144
-	4	4	2168083-9	SCR, SKT HD CAP, RoHS, M4 X 20	143
-	-	1	2119653-2	FEED CAM, POST FEED	142
-	1	1	1-1803583-0	APPLICATOR BASIC ASSEMBLY, SF	141
-	1	1	1803516-1	RAM ASSEMBLY, SF PACIFIC	140
-	1	1	2119955-1	ASSY, LUBRICATOR, SIDE FEED	113
-	1	1	2844908-1	SCREW, LOCKING	99
-	1	1	2844907-1	POST, LOCKING	98
-	1	1	455888-5	SPACER, CRIMPER	82
-	1	1	1803607-3	DOCUMENTATION PACKAGE	71
-	1	1	1803948-5	DEPRESSOR, WIRE, SPECIAL	70
-	1	1	2119740-1	TAG, IDENTIFICATION	67
-	2	2	2168078-1	SCREW, DRIVE, RH, RoHS, 2 x .188	66
-	1	1	5-18022-5	SCR, HEX HD CAP, M4 X 6.0	59
-	1	1	1338685-1	PAWL, FEED	56
-	2	2	1-2168083-0	SCR, SKT HD CAP, RoHS, M4 X 10	53
-	1	1	1803382-6	HOLD DOWN, SPRING LOADED	50
-	1	2	18023-9	SCR, SKT HD CAP M4 X 6.0	49
-	-	1	2119652-1	FEED CAM, PRE FEED	48
-	1	1	1803602-1	SCR, BHSC, RoHS (M8 X 25)	41
-	1	1	1-1752356-6	SUPPORT, TERMINAL	34
-	2	2	2079383-5	SCR, BHSC, RoHS (M4 X 20)	33
-	2	2	2-2844962-8	SPACER, CYLINDRICAL, STRIP GUIDE	30
-	1	1	2844992-2	ASSEMBLY, STRIP GUIDE	29
-	1	1	455888-5	SPACER, CRIMPER	28
-	1	1	1320928-6	STRIP GUIDE	24
-	1	1	2168083-2	SCR, SKT HD CAP, RoHS, M4 X 8.0	21
-	2	2	1-18028-2	WASHER, FLAT, REG M4	20
-	1	1	2119533-1	STRIPPER, SIDE FEED	19
-	1	1	2119806-1	INSERT, SHEAR	13
-	1	1	3-22280-3	SPRING, COMPRESSION	12
-	1	1	1-356885-4	STOP, SHEAR	11
-	1	1	2119805-1	SHEAR HOLDER, FRONT	10
-	1	1	1803095-1	FLOATING SHEAR, FRONT	9
1	1	1	1333204-2	ANVIL, COMBINATION	8
-	1	1	2119757-6	DEPRESSOR, SHEAR	5
-	1	1	238011-4	BLOCK, CRIMPER SPACER	4
1	1	1	2-1803199-6	CRIMPER, INSULATION OVERLAP PREMIUM	3
1	1	1	1803125-2	CRIMPER, WIRE	1

DIMENSIONS:		TOLERANCES UNLESS OTHERWISE SPECIFIED:		DRAWING NO		DESCRIPTION		ITEM NO
mm	0 PLC ±	1 PLC ±	2 PLC ±	3 PLC ±	4 PLC ±	ANGLES ±	FINISH	
MATERIAL								
Customer Accessible Production Drawing				SCALE	1:2	SHEET	3 of 4	REV



Ocean Side Feed
Applicator

SIZE: A1 | CAGE CODE: 00779 | DRAWING NO: C=2151099

FEED TYPE MECHANICAL

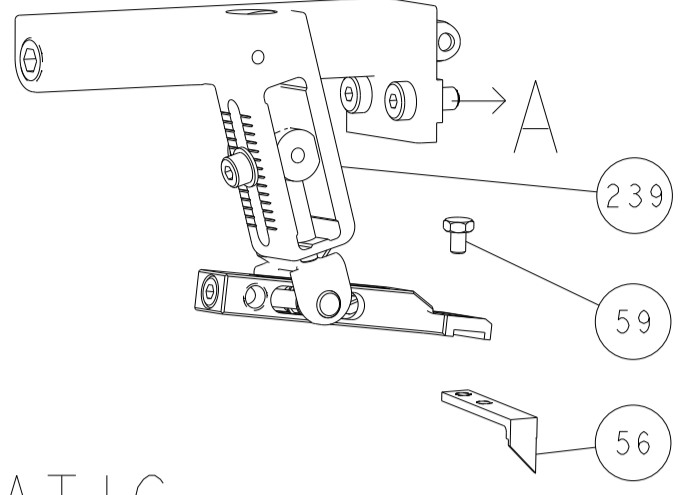

PNEUMATIC

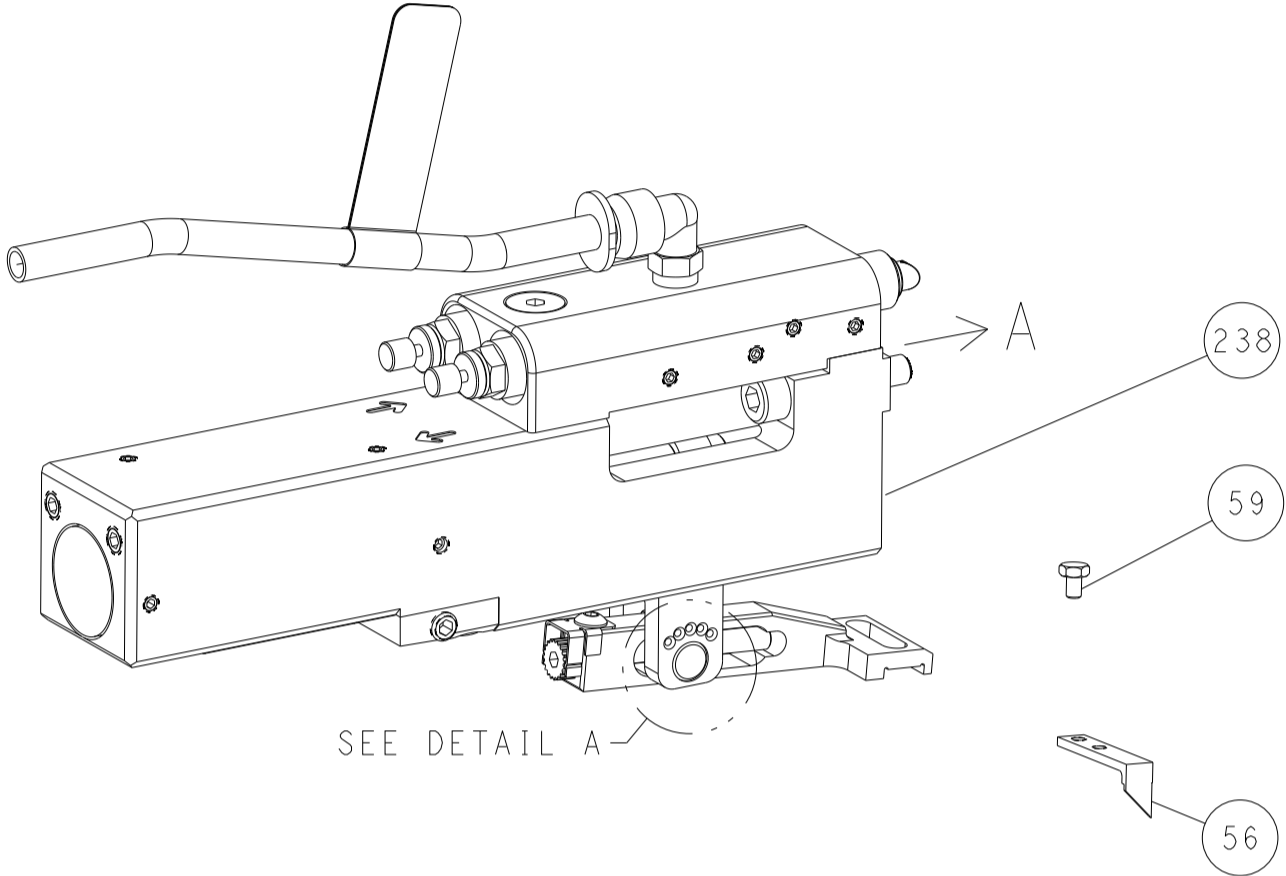

FEED SPRING SETTING POSITION (SHOWN FROM REAR SIDE)

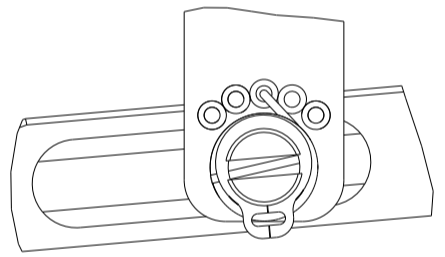

DETAIL A

CAM POSITIONS

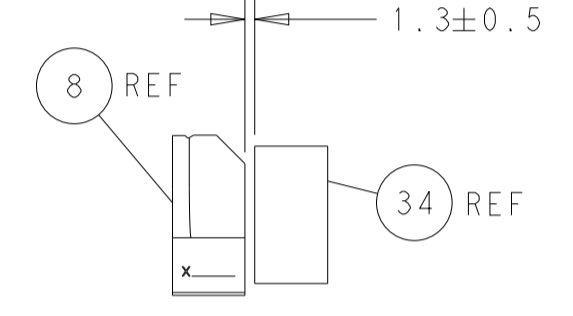
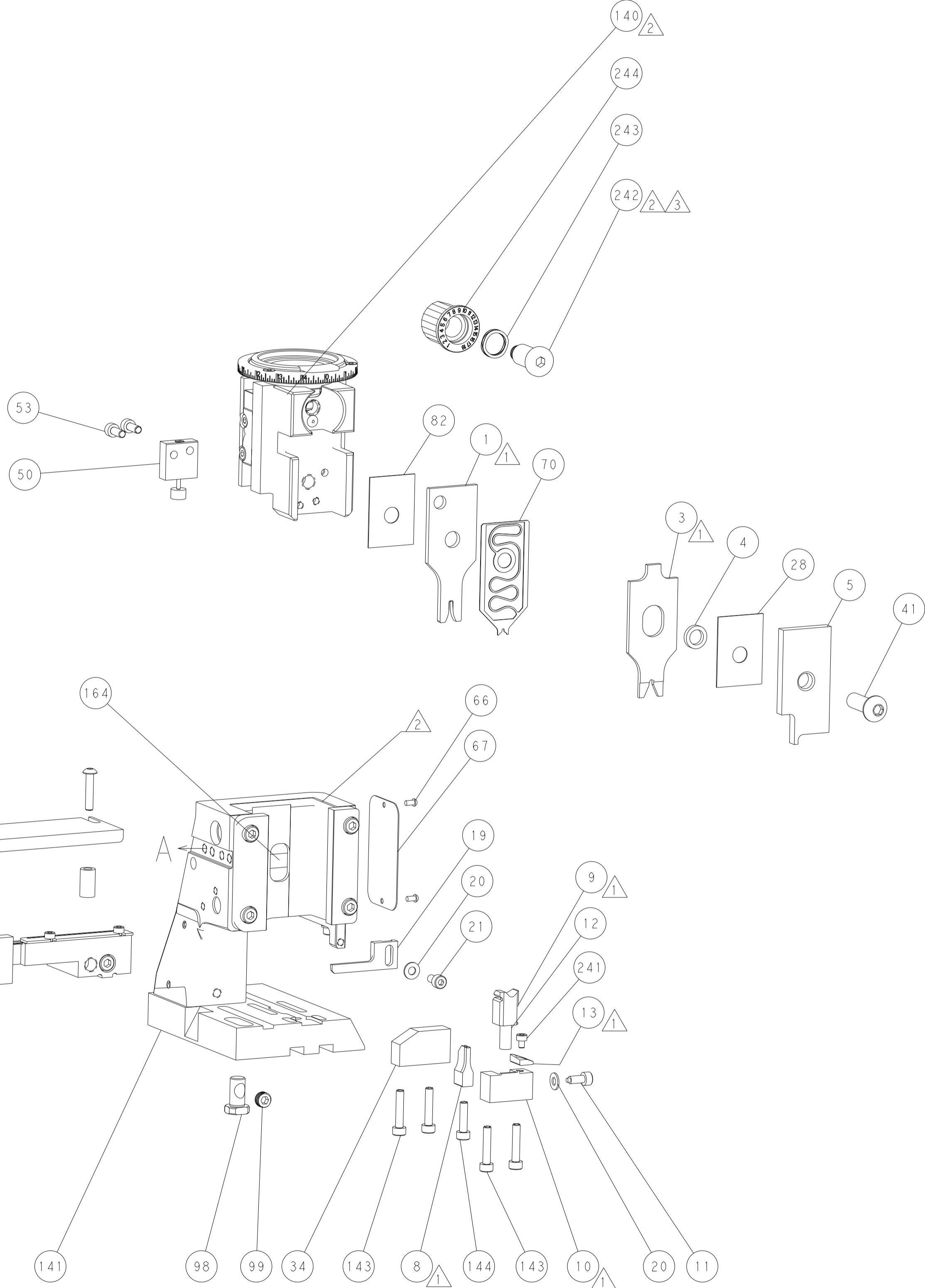
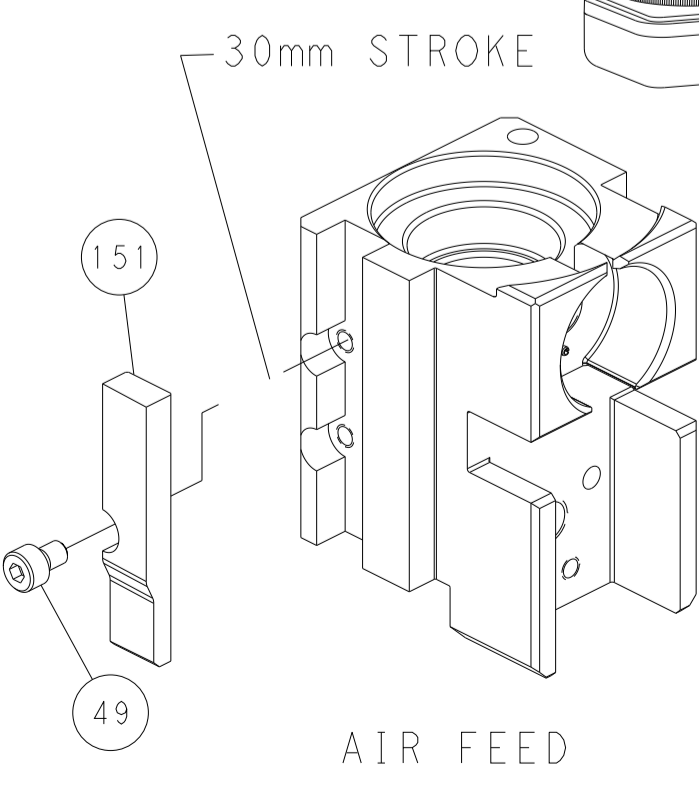
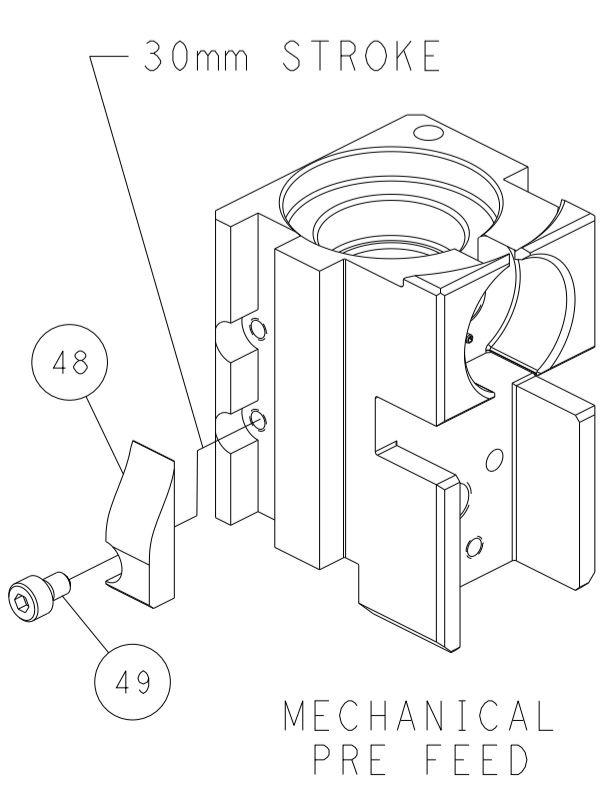
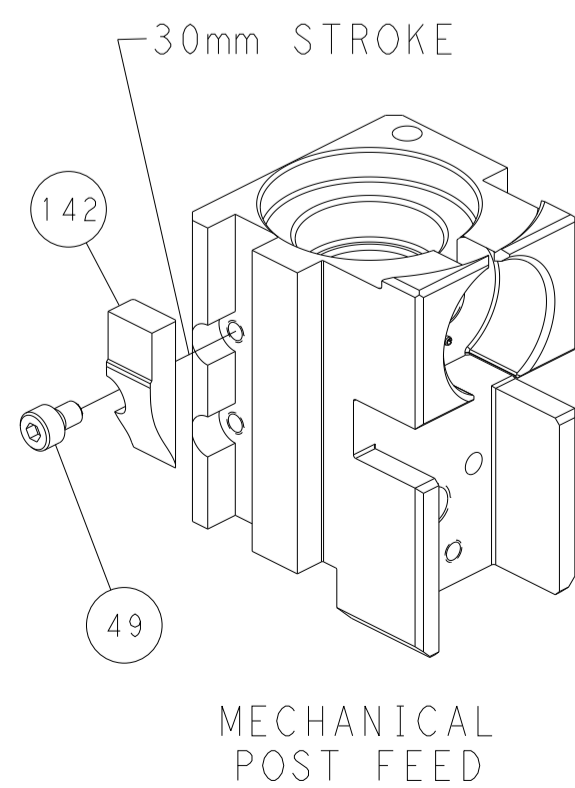

TERMINAL SUPPORT LOCATION

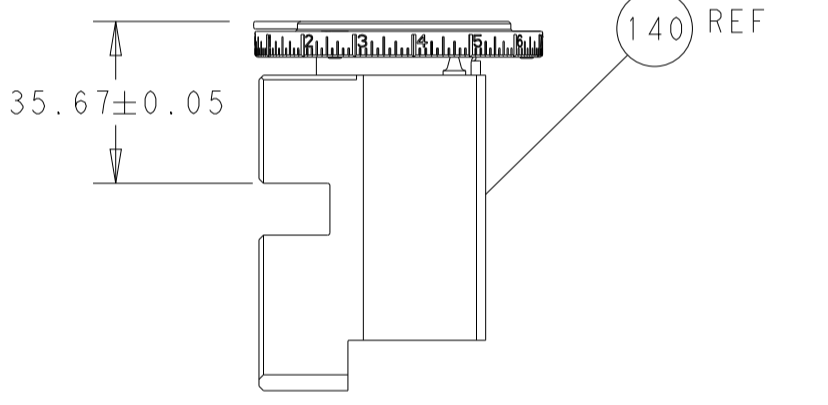

RAM SET-UP

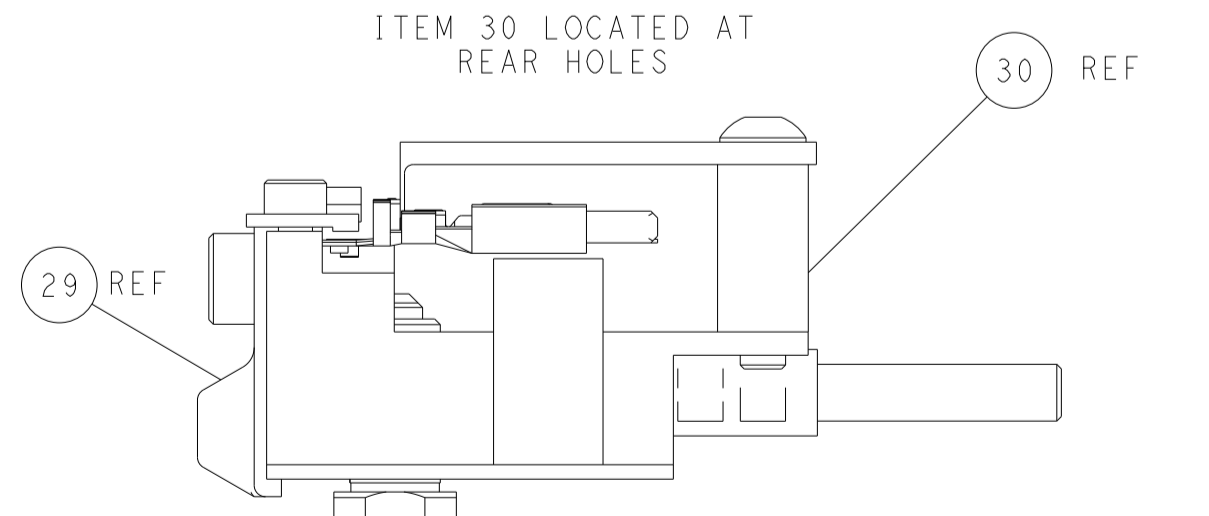

FEED TRACK POSITION
GUIDE BY INSULATION BARREL

PACIFIC VERSION
Shown on sheets 3 of 4 & 4 of 4
(Atlantic version shown on sheets 1 of 4 & 2 of 4)

LOC	DIST	REVISIONS					
		P	LTN	DESCRIPTION	DATE	OWN	APVD
A	66	-	-	SEE SHEET 1	-	-	-

<small>THIS DRAWING IS UNPUBLISHED. RELEASED FOR PUBLICATION 20</small> <small>BY TYCO ELECTRONICS CORPORATION. ALL RIGHTS RESERVED.</small>		<small>THIS DRAWING IS UNPUBLISHED. RELEASED FOR PUBLICATION 20</small> <small>BY TYCO ELECTRONICS CORPORATION. ALL RIGHTS RESERVED.</small>		<small>THIS DRAWING IS UNPUBLISHED. RELEASED FOR PUBLICATION 20</small> <small>BY TYCO ELECTRONICS CORPORATION. ALL RIGHTS RESERVED.</small>		<small>THIS DRAWING IS UNPUBLISHED. RELEASED FOR PUBLICATION 20</small> <small>BY TYCO ELECTRONICS CORPORATION. ALL RIGHTS RESERVED.</small>		<small>THIS DRAWING IS UNPUBLISHED. RELEASED FOR PUBLICATION 20</small> <small>BY TYCO ELECTRONICS CORPORATION. ALL RIGHTS RESERVED.</small>		
DIMENSIONS: mm		TOLERANCES UNLESS OTHERWISE SPECIFIED: 0 PLC ± 1 PLC ± 2 PLC ± 3 PLC ± 4 PLC ± ANGLES ± FINISH		DWG Y. YIN 22AUG2011 CHK G. BAILEY 22AUG2011 APVD S. XI 22AUG2011 PRODUCT SPEC APPLICATION SPEC WEIGHT		NAME Ocean Side Feed Applicator		SIZE CAGE CODE DRAWING NO A1 00779 C=2151099		RESTRICTED TO REV 1
MATERIAL:		CUSTOMER ACCESSIBLE PRODUCTION DRAWING		SCALE 1:2		SHEET 4 OF 4		REV 1		