

CONNECTOR ASSEMBLY CHART:			
FORD ASSEMBLY PART NUMBER:	MOLEX ASSEMBLY PART NUMBER:	MAX TEMP (°C):	VIBRATION CLASS:
HUST-14489-DA	160044-0100	105	V1
HUST-14489-ED	160044-0101		
TBD	160044-0102		
TBD	160044-0103		

ITEM#	PIA DESCRIPTION:	COLOR:	MOLEX COMPONENT PART NUMBER:	RECYCLING CODE:	WEIGHT (kg):	NUMBER OF ITEMS REQUIRED:
1	50 CKT B479 PDB RECEPTACLE HOUSING POL A	BLACK	160044-0200	PA66 GF35%	0.0538	1
2	50 CKT B479 PDB RECEPTACLE HOUSING POL B	LT GRAY	160044-0201	PA66 GF35%	0.0538	1
3	50 CKT B479 PDB RECEPTACLE HOUSING POL C	DK GRAY	160044-0202	PA66 GF35%	0.0539	1
4	50 CKT B479 PDB RECEPTACLE HOUSING POL D	TBD	160044-0204	PA66 GF35%	0.0539	1
5	TPA	NATURAL	160044-0300	SPS/PA66 GF30%	0.0104	1 1 1 1 1
6	LEVER	LT GRAY	160044-0400	PA66 GF35%	0.0088	1 1 1 1 1
7	PINION GEAR	LT GRAY	160044-0500	PA66 GF35%	0.0006	2 2 2 2 2

APPLICABLE COMPONENTS:							
ITEM#	DESCRIPTION:	MANDATORY (YES/NO)	TERMINAL CAVITY MIN/MAX OD:	PLATING/MATERIAL:	FORD COMPONENT PART NUMBER:	SUPPLIER COMPONENT PART NUMBER:	TERMINAL REFERENCE CODES (TRC)
1	B386 DELPHI APEX TERMINAL/2.8mm (APPLICABLE CAVITIES)	YES	1.40mm/2.10mm	TIN	F8VB-14474-BA	54001839 (FCI)	B386
			2.20mm/3.00mm	TIN	F8VB-14474-AA	54001431 (FCI)	
			3.10mm/3.40mm	TIN	7L7T-14474-EA	54001227 (FCI)	
			3.40mm/4.30mm	TIN	XF2T-14474-BA	54001018 (FCI)	
2	B474 DELPHI APEX TERMINAL/6.35mm (APPLICABLE CAVITIES)	YES	1.70mm/2.40mm	TIN	DUST-14474-TA	F286010 (FCI)	B474
			2.70mm/3.00mm	TIN	CUST-14474-RA	F409110 (FCI)	
			3.40mm/5.00mm	TIN	YFIT-14474-BA	54001007 (FCI)	
3	WIRE DRESS COVER	YES	N/A	PA66 GF35%	HUST-14N003-CA	160044-0600 (MOLEX)	N/A

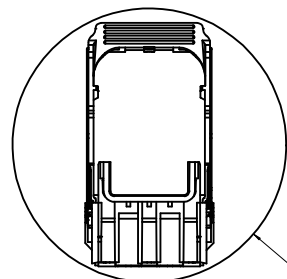
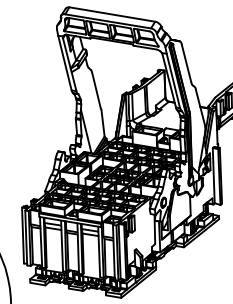

(ø108.65)
PASS THRU DIAMETER WITH 2mm ADDITIONAL CLEARANCE

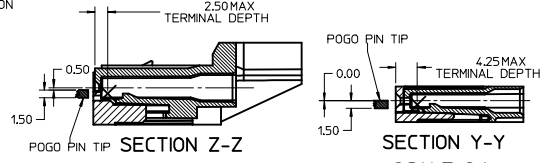
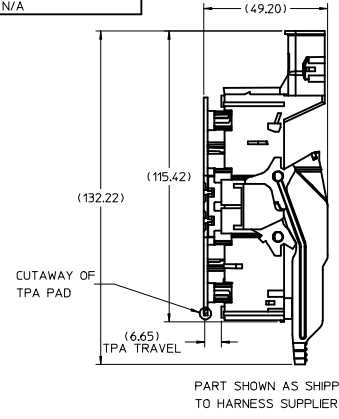
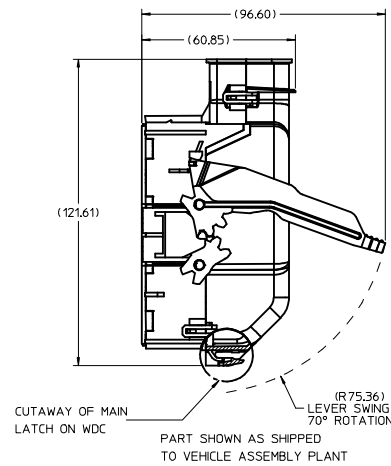
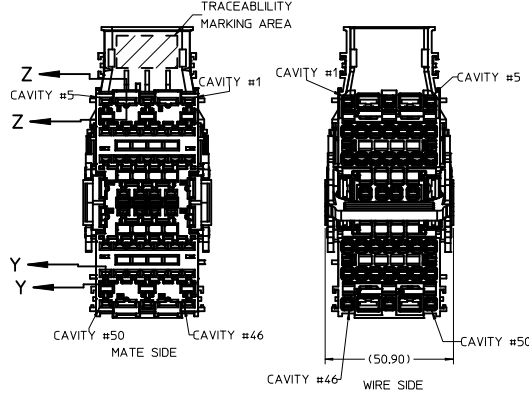

SECTION Z-Z SCALE 2:1 6.35mm TERMINAL CAVITY
SECTION Y-Y SCALE 2:1 2.8mm TERMINAL CAVITY

FOR POGO PIN TESTING, THE MAXIMUM FORCE OF THE POGO PIN IS NOT TO EXCEED 3 NEWTONS.

- NOTES: UNLESS OTHERWISE SPECIFIED
- PARTS CONFORM TO THE ELECTRICAL CONNECTION SYSTEM DESIGN SPECIFICATION (SDS) 4-10-2014
 - PART CONFORMS TO USCAR-2 REV 6
 - MAXIMUM MATING FORCE FULL POPULATED WITH TIN TERMINALS <75N
 - TERMINAL EXTRACTION TOOL REFERENCE NOTE
 - N/A
 - CONNECTOR IS RATED AS EGONOMIC CLASS 3 BASED ON USCAR-25 REV 1. CONNECTOR PUSH SURFACE AREA IS 439.4mm²
 - PARTS MEET MATERIAL CONTROL FOR BLACK AND GRAY BOX COMPONENTS (WSS-M99P23-C1 & C2)
 - KEEP OUT AREA FOR HEADER INTERFACE PER USCAR-25.

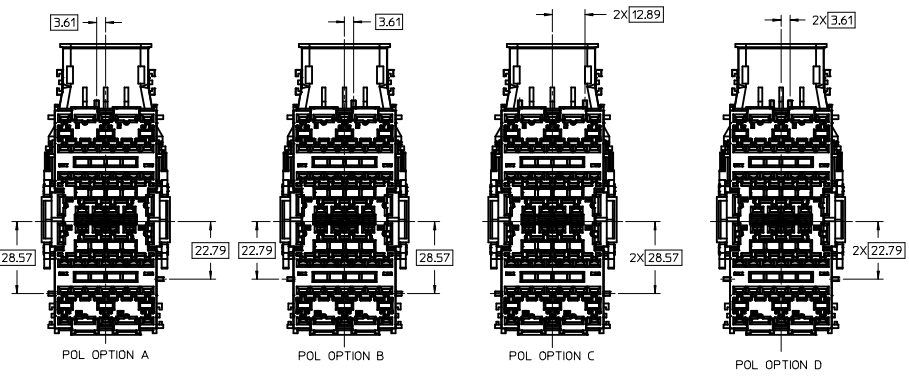

PART NUMBERS
HUST-14489-EA

LTRS.				REVISIONS	
ORIGINATOR	CHECKER	ENGR APP	MATL APP		
RELEASED FOLLOWING PART NUMBERS					
HUST-14489-DA					
HUST-14489-EA					
AELE-E-11776560-823		2014/06/25			
MYOUNG	RBAUMAN	MSALANTA			
B UPDATED DRAWING TO MEET FORD DRAFTING SPECIFICATIONS					
AELE-E-11776560-864		2014/08/25			
MYOUNG	RBAUMAN	MSALANTA			

REFERENCE ---					
PART MUST COMPLY WITH MATERIAL SPECIFICATION WSS-M99P9999-A1 TO HELP SAFEGUARD HEALTH, SAFETY AND THE ENVIRONMENT.					
DRAFTED IN ACCORDANCE WITH FAO ENGINEERING DRAFTING STANDARD CURRENT AT INITIAL RELEASE					3RD ANGLE PROJ DIMENSIONS IN MILLIMETERS
CAD TYPE	CAD LOC.	CAD FILE	IS MASTER		
OPER. NO.	UNIT	DRAWING	HUST-14489-DA		
DESIGN MYOUNG01	DETAIL	TITLE	SLV WIR CONN FEM		
CHECKED RBAUMAN	SAFETY				BHT 1 OF 3
SCALE 1:1	DATE 2014/06/25	DIVISION PLANT			

DRW SIZE A/D

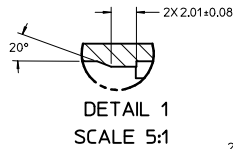
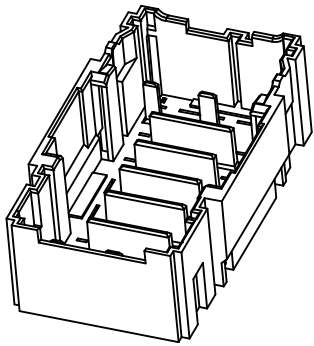

DETAIL 1
SCALE 5:1

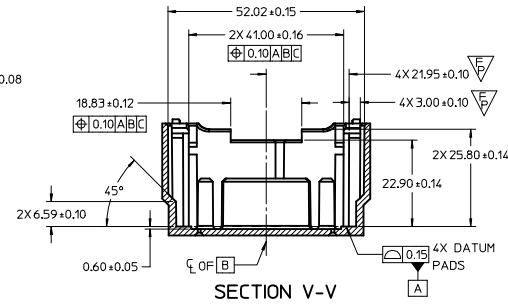

SECTION V-V

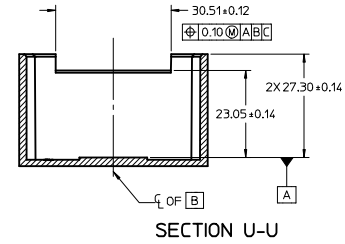

SECTION U-U

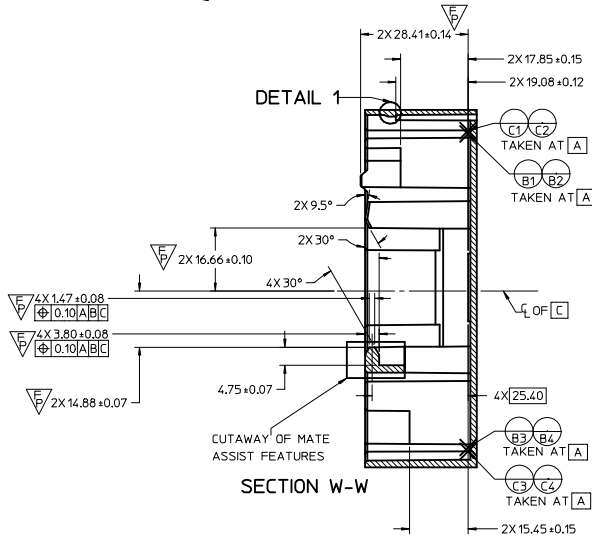

SECTION W-W

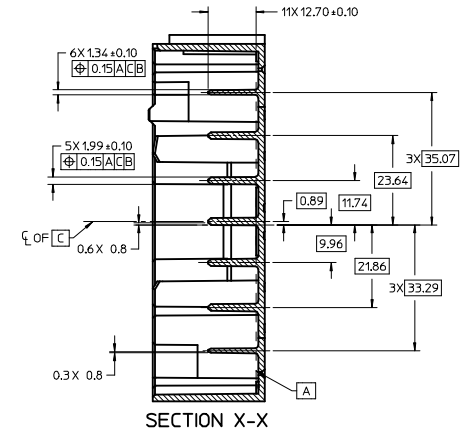
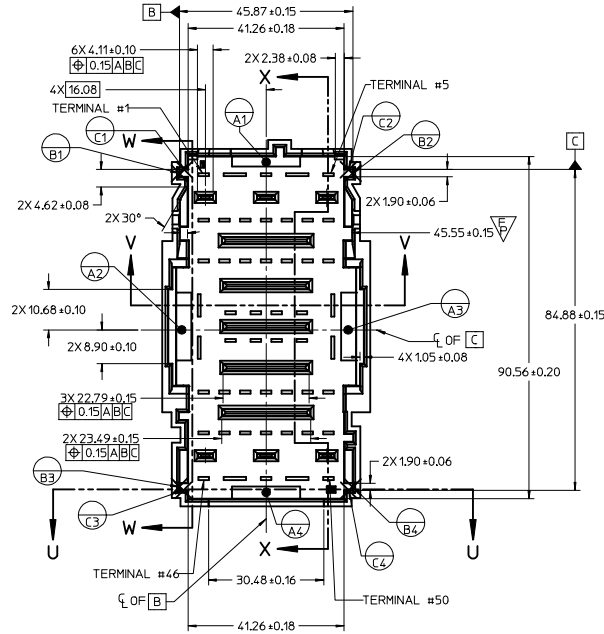

SECTION X-X

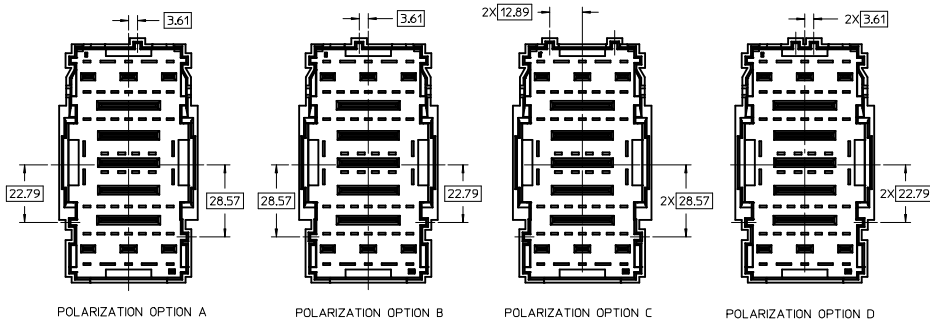

POLARIZATION OPTION A

POLARIZATION OPTION B

POLARIZATION OPTION C

POLARIZATION OPTION D

NOT VALIDATED
PROTO RELEASE

-INTERFACE MATERIAL MUST MEET A MINIMUM 65MPa TENSILE STRENGTH AT OPERATING TEMPERATURE (105°C)

-INTERFACE FLOOR STRENGTH RECOMMENDATION/REQUIREMENT

- DEVICE SUPPLIER MUST DESIGN FOR FORCES UP TO 540N BEING APPLIED TO THE TERMINAL BLADES DURING THE MATING AND UN-MATING PROCESS.

-INTERFACE WALL STRENGTH RECOMMENDATION/REQUIREMENT

- DEVICE SUPPLIER MUST ADEQUATELY SUPPORT THE SIDE-WALLS OF THE INTERFACE WHICH IS DEPENDENT ON THEIR APPLICATION, MATERIAL TYPE, INTERFACE ORIENTATION AND IS SUBJECT TO REVIEW AND APPROVAL BY THE INTERFACE OWNER(MOLEX) DURING MODULE DEVELOPMENT.

LTRS.		REVISIONS		
ORIGINATOR	CHECKER	ENGR APP	MATL APP	

REFERENCE ---				
PART MUST COMPLY WITH MATERIAL SPECIFICATION WSS-M99P9999-A1 TO HELP SAFEGUARD HEALTH, SAFETY AND THE ENVIRONMENT.				
DRAFTED IN ACCORDANCE WITH FAO ENGINEERING DRAFTING STANDARD CURRENT AT INITIAL RELEASE				3RD ANGLE PROJ DIMENSIONS IN MILLIMETERS
CAD TYPE	CAD LOC.	CAD FILE	IS MASTER	
OPER. NO.	UNIT	DRAWING	HU5T-14489-DA	
DESIGN MYOUNG01	DETAIL	TITLE	SLV WIR CONN FEM	
CHECKED RBAUMAN	SAFETY			SHT 2 OF 3
SCALE 1:1	DATE 2014/06/25	DIVISION PLANT		

DRW SIZE A/D

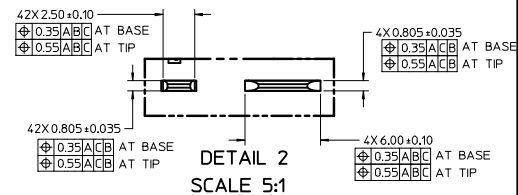
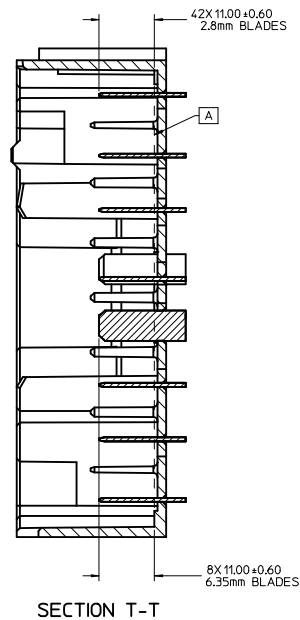
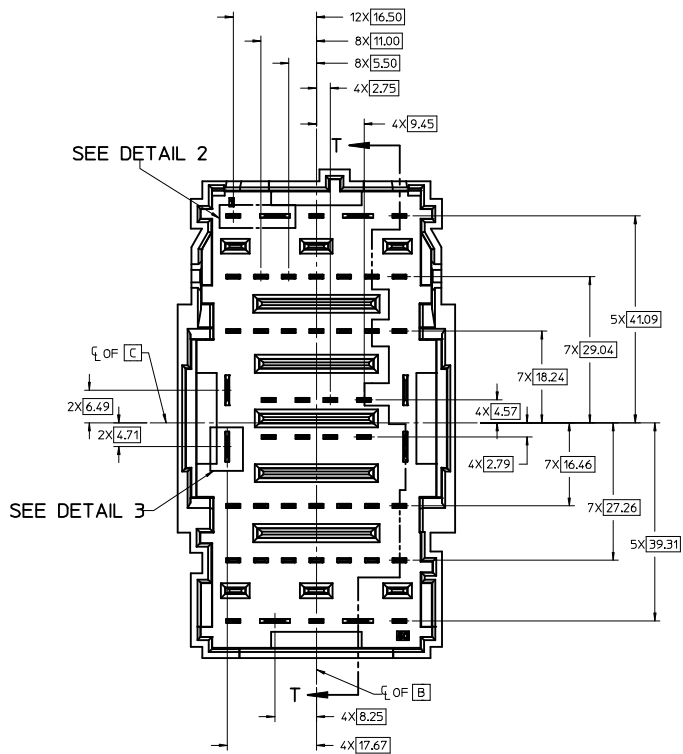

DETAIL 2
SCALE 5:1

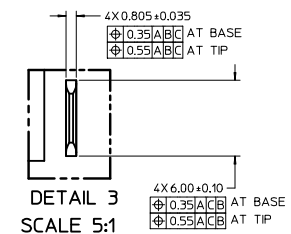

DETAIL 3
SCALE 5:1

LTRS.	REVISIONS		
	ORIGINATOR	CHECKER	ENGR APP

BLADE GEOMETRY AND CONSTRUCTION PER EWCAP-001
HEADER CONSTRUCTION AND HOT TIN DIP PLATING

REFERENCE ---			
PART MUST COMPLY WITH MATERIAL SPECIFICATION WSS-M99P9999-A1 TO HELP SAFEGUARD HEALTH, SAFETY AND THE ENVIRONMENT.			
DRAFTED IN ACCORDANCE WITH FAO ENGINEERING DRAFTING STANDARD CURRENT AT INITIAL RELEASE			3RD ANGLE PROJ DIMENSIONS IN MILLIMETERS
CAD TYPE	CAD LOC.	CAD FILE	IS MASTER
OPER. NO.	UNIT	DRAWING	HUST-14489-DA
DESIGN MYOUNG01	DETAIL ---	TITLE	SLV WIR CONN FEM
CHECKED RBAUMAN	SAFETY		8HT 3 OF 3
SCALE 2:1	DATE 2014/06/25	DIVISION PLANT	

DRW SIZE A/D