

PART NUMBER	SSL-LXT046UV3C	REV.	B
DATE	E.C.N. NUMBER AND REVISION COMMENTS		REV.
04.12.10	E.C.N. #11856.		A
06.28.13	E.C.N. #10886R. & REDRAWN.		B

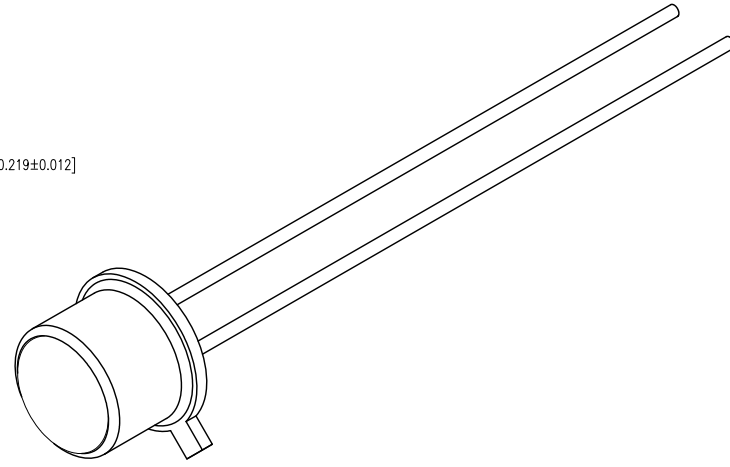
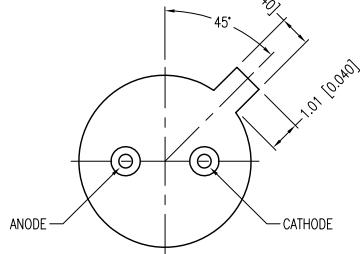
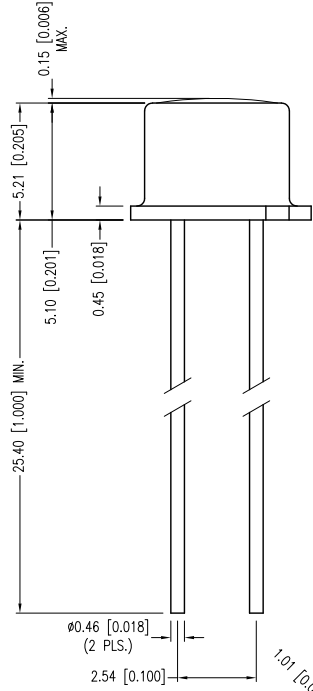
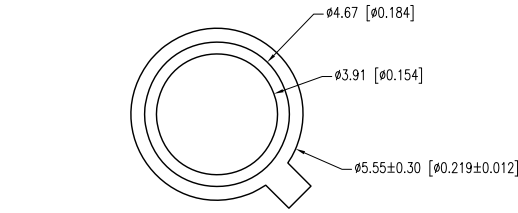

**A** ELECTRO-OPTICAL CHARACTERISTICS TA =25°C If=20mA

PARAMETER	MIN	TYP.	MAX	UNITS	TEST COND
PEAK WAVELENGTH	410	415	420	nm	
FORWARD VOLTAGE		3.3	3.6	Vf	
REVERSE VOLTAGE	5.0			Vr	If=1µA
TOTAL POWER OUTPUT	4.0	6.0		mW	If=20mA
VIEWING ANGLE		80		DEGREES	
EMITTED COLOR:	ULTRA VIOLET				
EPOXY LENS FINISH:	WATER CLEAR				

LIMITS OF SAFE OPERATION AT 25°C

PARAMETER	MAX	UNITS
PEAK FORWARD CURRENT*	120	mA
STEADY CURRENT	30	mA
POWER DISSIPATION	200	mW
OPERATING TEMP.	-40 TO +100	°C
STORAGE TEMP.	-40 TO +100	°C
SOLDERING TEMP.	+260	°C
2.0mm FROM BODY	3	SEC. MAX.

\*1/10 DUTY CYCLE AT 1kHz

THERMAL PARAMETERS

PARAMETER	VALUE	UNITS
MAXIMUM JUNCTION TEMPERATURE	125	°C
THERMAL RESISTANCE JUNCTION-AIR	400	°C/W
THERMAL RESISTANCE JUNCTION-CASE	138	°C/W

CAUTION: STATIC SENSITIVE DEVICE  
FOLLOW PROPER E.S.D. HANDLING PROCEDURES  
WHEN WORKING WITH THIS PART.

**B**

\*UNLESS OTHERWISE SPECIFIED TOLERANCES PER DECIMAL PRECISION ARE: X=±1 (±0.039), X.X=±0.5 (±0.020), X.XX=±0.25 (±0.010), X.XXX=±0.127 (±0.005). LEAD SIZE=±0.05 (±0.002), LEAD LENGTH=±0.75 (±0.030). MIN.= +DECIMAL PRECISION MAX.= +0.00 -0.00 DECIMAL PRECISION

**LUMEX**  
Creating LED and LCD Solutions Together™

425 N. GARY AVE.  
CAROL STREAM, IL 60188-4900  
PHONE: +1.800.278.5666  
FAX: +1.630.315.2152  
WEB: WWW.LUMEX.COM  
MEMBER OF THE PHOTONICS GROUP

377nm UV LED, T0-46 CAN PACKAGE.

CONFIDENTIAL INFORMATION  
THE INFORMATION CONTAINED IN THIS DOCUMENT IS THE PROPERTY OF LUMEX INC. EXCEPT AS SPECIFICALLY AUTHORIZED IN WRITING BY LUMEX INC., THE HOLDER OF THIS DOCUMENT SHALL KEEP ALL INFORMATION CONTAINED HEREIN CONFIDENTIAL AND SHALL PROTECT SAME IN WHOLE OR IN PART FROM DISCLOSURE AND DISSEMINATION TO ALL THIRD PARTIES.

DATE:	06.28.11	DRAWN BY:	AB
PAGE:	1 OF 1	CHKD BY:	KF
SCALE:	NTS	APRVD BY:	BC
UNIT:	mm [INCH]		