

# SCM10 USB 2.0 Common Mode Choke

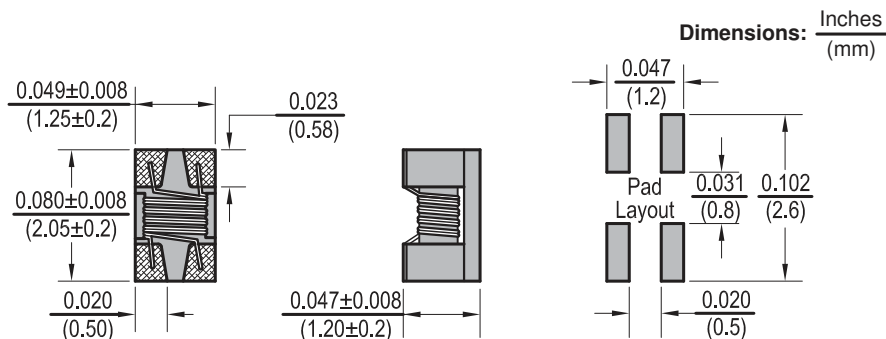

## Features

- Miniature SMD common mode filter
- Excellent noise attenuation in a small package
- Suitable for automated assembly
- SCM series offers wide impedance range
- Cost effective monolithic construction

## Electrical

**Impedance range:** 30  $\Omega$  to 900 $\Omega$

**Tolerance:** 20% over entire range

**Test Frequency:** 100MHz

**Operating Temp:** -40°C ~ +150°C

**IDC:** Inductance drop 10% Typ. from original value with no current

**DCR:** Single Wire Test Value

## Resistance to Solder Heat

Pre-Heat 150°C, 1 minute

**Solder Composition:** Sn/Ag3.0/Cu0.5

**Solder Temp:** 260°C peak for 10 sec.

**Test time:** 6 minutes

## Test Equipment

**Impedance:** HP4286A/HP4287A /

Agilent E4991A

**(DCR):** Chen Hwa 502BC

**Insulation Resistance:** HP4339B

**(IDC):** HP4284A with HP42841A/

HP4285A with HP42841A

Allied Part Number	Impedance Z ( $\Omega$ )	Tolerance (%)	Test Freq. (MHz)	Rated Voltage (Vdc)	Insulation Resistance (M $\Omega$ )min	DCR Max. ( $\Omega$ )	IDC Max. (mA)
SCM10-300M-RC	30	20	100	120	10	0.20	450
SCM10-670M-RC	67	20	100	120	10	0.25	400
SCM10-750M-RC	75	20	100	120	10	0.20	360
SCM10-900M-RC	90	20	100	120	10	0.35	330
SCM10-121M-RC	120	20	100	120	10	0.30	400
SCM10-161M-RC	160	20	100	120	10	0.35	350
SCM10-181M-RC	180	20	100	120	10	0.35	330
SCM10-201M-RC	200	20	100	120	10	0.35	330
SCM10-221M-RC	220	20	100	120	10	0.35	310
SCM10-261M-RC	260	20	100	120	10	0.40	300
SCM10-301M-RC	300	20	100	120	10	0.40	290
SCM10-361M-RC	360	20	100	120	10	0.45	280
SCM10-371M-RC	370	20	100	120	10	0.45	280
SCM10-501M-RC	500	20	100	120	10	0.55	170
SCM10-671M-RC	670	20	100	120	10	0.60	140
SCM10-901M-RC	900	20	100	120	10	0.60	80

All specifications subject to change without notice.

## Physical

**Packaging:** 2000 pieces per 7 inch reel

**Marking:** None

## SCHEMATIC

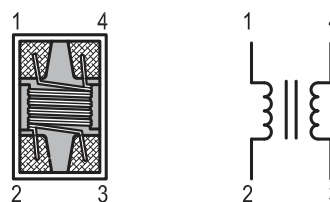

NO POLARITY EQUIVALENT CIRCUIT