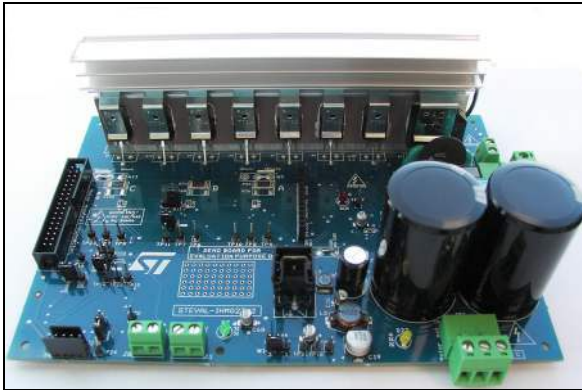


## 1 kW 3-phase motor control evaluation board featuring L6390 drivers and STGP10H60DF IGBT

Data brief



### Features

- Minimum input voltage: 125 VDC or 90 VAC
- Maximum input voltage: 400 VDC or 285 VAC
- Input voltage range with applied input voltage doubler from 65 VAC to 145 VAC
- Voltage range for low-voltage motor control applications from 18 VDC to 35 VDC
- Possibility to use auxiliary +15 V supply voltage
- Maximum output power for motors: up to 1 kW
- Regenerative brake control
- Input inrush limitation with bypass relay
- + 15 V auxiliary power supply based on buck converter with VIPer16
- IGBT power switch STGP10H60DF in a TO-220 package - compatible with other ST IGBTs or power MOSFETs in the TO-220 package
- Fully populated board design with test points and isolated plastic cover for safety
- Motor control connector for interface with the STM3210B-EVAL board and other ST motor control dedicated kits
- Tachometer input
- Hall/encoder inputs
- Possibility to connect BEMF daughterboard for sensorless six-step control of BLDC motors

- PCB type and size:
  - PCB material: FR-4
  - Double-sided layout
  - Copper thickness: 60  $\mu\text{m}$
  - Total dimensions of board: 127 mm x 180 mm
- RoHS compliant

### Description

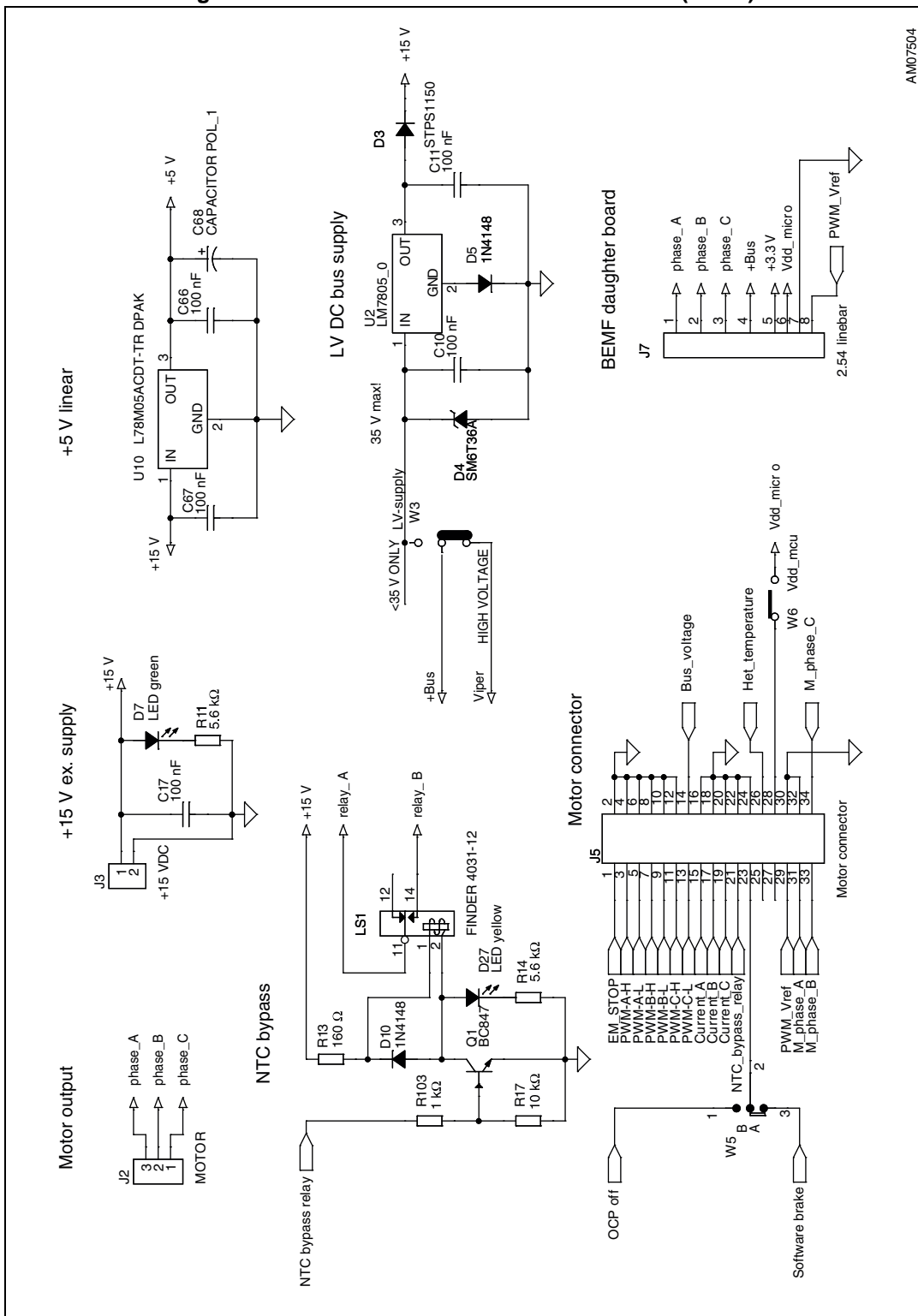
The STEVAL-IHM023V3 evaluation board implements a 1 kW three-phase motor control application featuring L6390 high and low-side driver and the STGP10H60DF IGBT. The evaluation board is an AC-DC inverter that generates a three-phase waveform for driving two- or three-phase motors such as induction motors or PMSM motors up to 1000 W, with or without sensors.

The STEVAL-IHM023V3 is a universal, fully evaluated and populated design consisting of a three-phase inverter bridge based on STMicroelectronics' 600 V IGBT STGP10H60DF in a TO-220 package mounted on a heatsink, and the L6390 high-voltage high-side and low-side driver featuring an integrated comparator for hardware protection features such as overcurrent and overtemperature. The driver also integrates an operational amplifier suitable for advanced current sensing. Thanks to this advanced characteristic, the system achieves accurate and fast conditioning of the current feedback, addressing the typical requirements of field-oriented control (FOC). The board has been designed to be compatible with a single-phase mains, supplying from 90 VAC to 285 VAC or from 125 VDC to 400 VDC for DC voltage. With reconfiguration of the input sourcing, the board is suitable also for low-voltage DC applications up to 35 VDC.





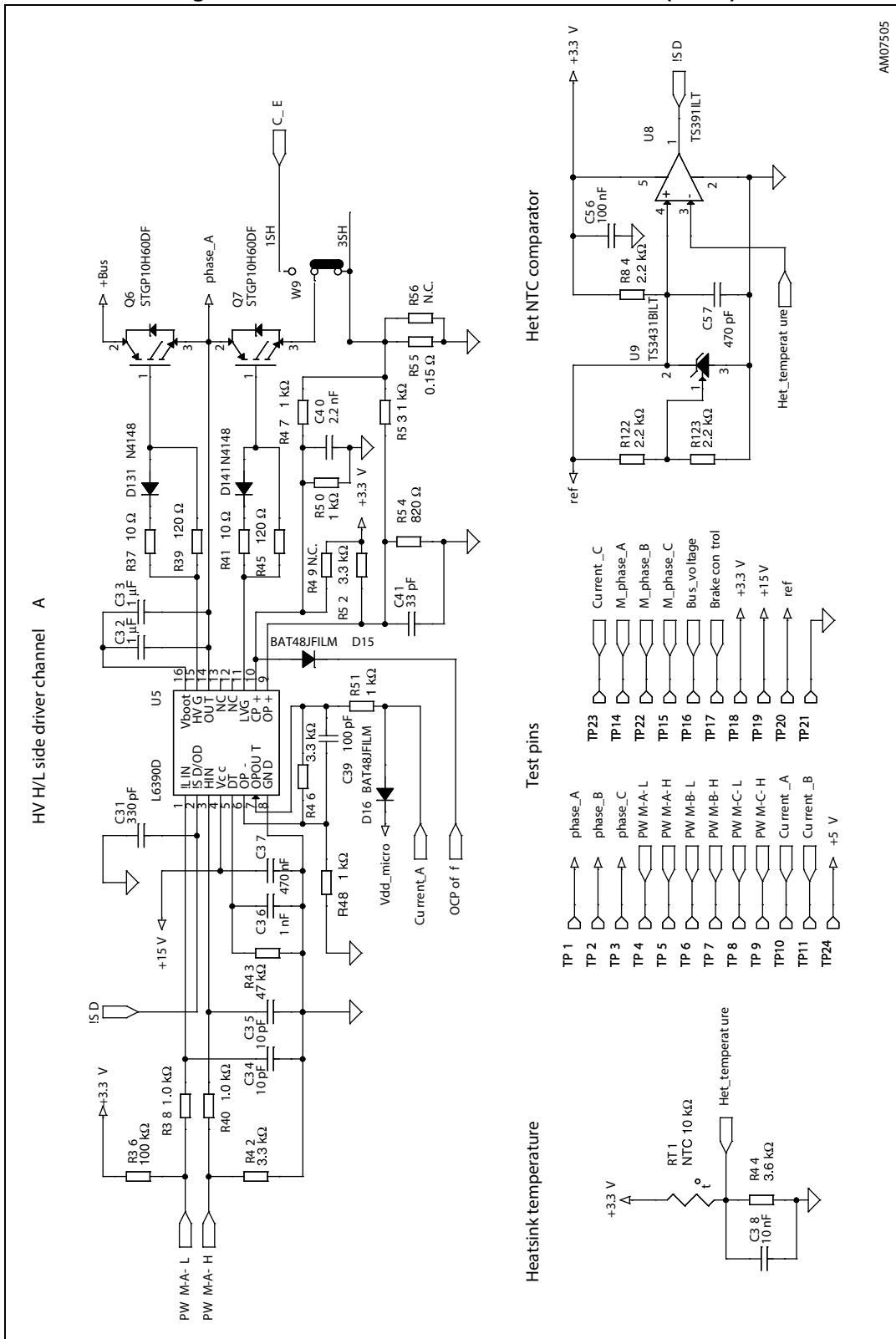
Figure 3. STEVAL-IHM023V3 circuit schematic (3 of 6)



AM07504

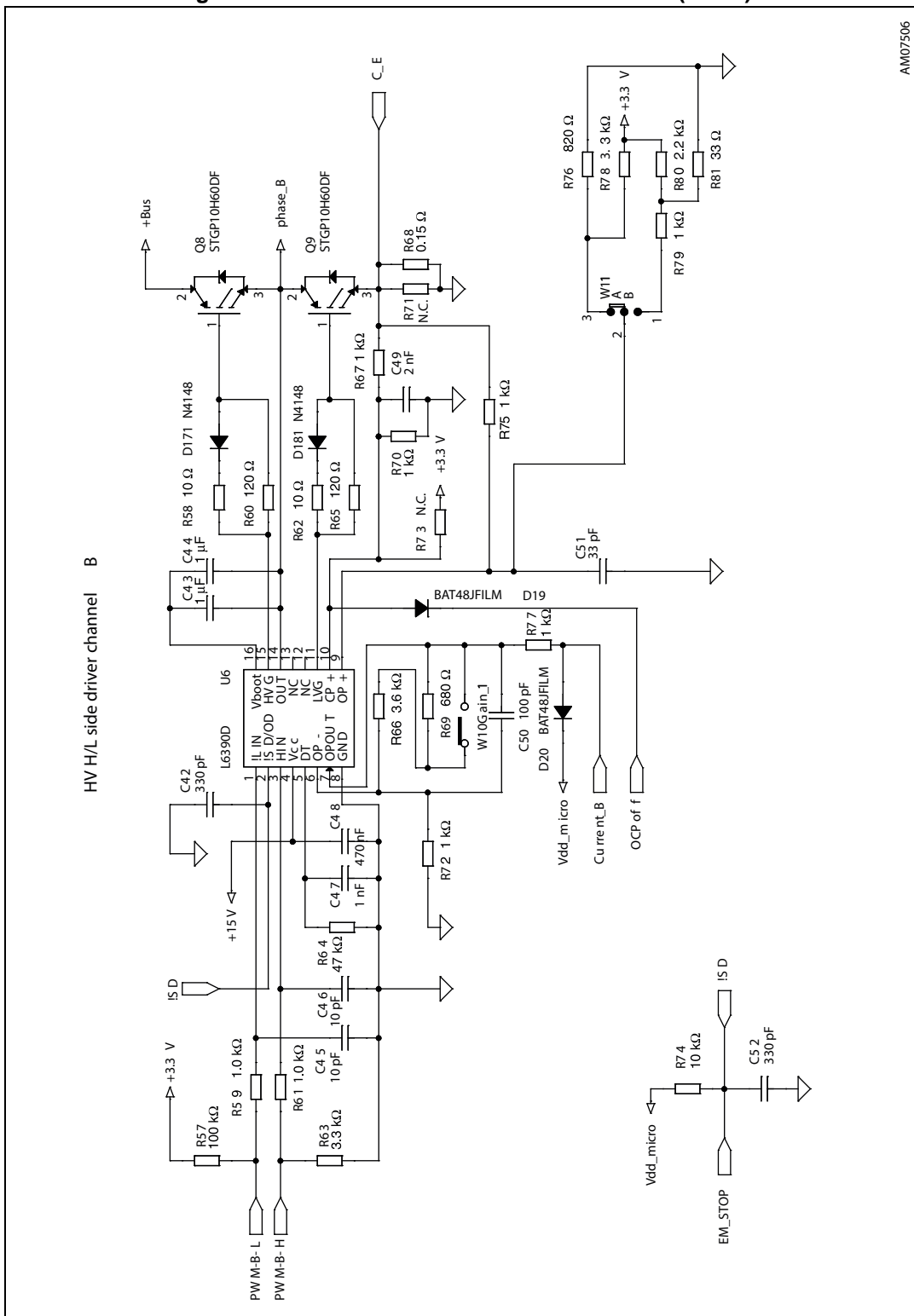


Figure 4. STEVAL-IHM023V3 circuit schematic (4 of 6)



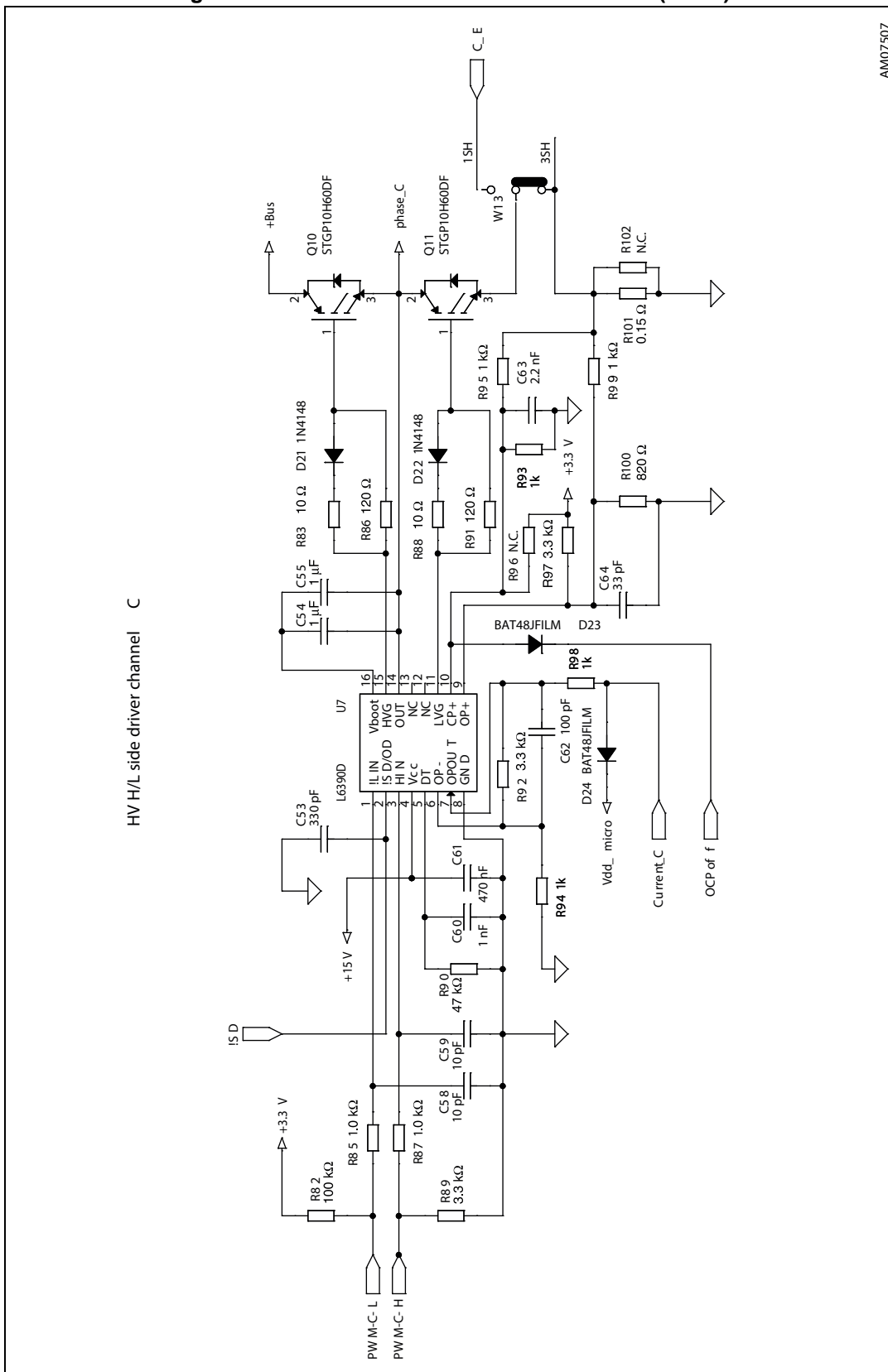
AM07505

Figure 5. STEVAL-IHM023V3 circuit schematic (5 of 6)



AM07506

Figure 6. STEVAL-IHM023V3 circuit schematic (6 of 6)



## 2 Revision history

Table 1. Document revision history

Date	Revision	Changes
04-Nov-2014	1	Initial release.



**IMPORTANT NOTICE – PLEASE READ CAREFULLY**

STMicroelectronics NV and its subsidiaries ("ST") reserve the right to make changes, corrections, enhancements, modifications, and improvements to ST products and/or to this document at any time without notice. Purchasers should obtain the latest relevant information on ST products before placing orders. ST products are sold pursuant to ST's terms and conditions of sale in place at the time of order acknowledgement.

Purchasers are solely responsible for the choice, selection, and use of ST products and ST assumes no liability for application assistance or the design of Purchasers' products.

No license, express or implied, to any intellectual property right is granted by ST herein.

Resale of ST products with provisions different from the information set forth herein shall void any warranty granted by ST for such product.

ST and the ST logo are trademarks of ST. All other product or service names are the property of their respective owners.

Information in this document supersedes and replaces information previously supplied in any prior versions of this document.

© 2014 STMicroelectronics – All rights reserved

