



## Product brief

# EiceDRIVER™ 2EDF7275F and 2EDF7175F

Fast, robust, dual-channel, functional isolated MOSFET gate drivers with accurate and stable timing

### Overview

The EiceDRIVER™ 2EDF7275F is the perfect fit for robust and stable operation for primary side control of high- and low-side MOSFETs in noisy high-power switching environments. The strong 4 A/8 A source/sink dual-channel gate drivers provide a fast turn on/off when driving high- and medium-voltage MOSFETs such as CoolMOS™ or OptiMOS™. Both output channels are individually isolated and can be flexibly deployed as floating gate drivers with very high 150 V/ns CMTI (Common Mode Noise Immunity). The VDDi input supply supports a wide voltage range SLDO mode to save on-board LDOs. For slower switching or driving smaller MOSFETs, a 1 A/2 A peak current product variant, the EiceDRIVER™ 2EDF7175F, is available in the DSO-16 narrow body package with 4 mm creepage distance.

### Device overview

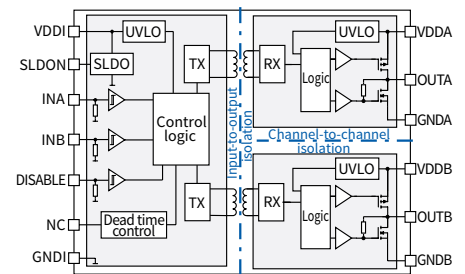

EiceDRIVER™ 2EDF7275F and 2EDF7175F block diagram

Product key features	Product benefits	System benefits
<b>Fast power switching with accurate timing</b> <ul style="list-style-type: none"> <li>Available with 4 A/8 A and 1 A/2 A source/sink currents</li> <li>Propagation delay typ. 37 ns with 3 ns channel-to-channel mismatch</li> <li>Max. delay variation ~14 ns</li> </ul>	<b>Power efficiency and high resolution PWM control</b> <ul style="list-style-type: none"> <li>Lower switching losses in half-bridges due to fast and accurate turn on/off</li> <li>Perfect match for a new digitally controlled high resolution PWM control</li> </ul>	<b>Enabling higher power stage efficiency and higher power density designs</b>
<b>Optimized for area and low cost system BOM</b> <ul style="list-style-type: none"> <li>Isolation and driver in one package</li> <li>Less power dissipation due to low on-resistance</li> <li>Output stages with 5 A reverse current capability</li> </ul>	<b>Cooler package at smaller form factor</b> <ul style="list-style-type: none"> <li>Replaces classic bulky PT pulse transformers or costly high speed data couplers and discrete drivers</li> <li>Cooler gate driver package</li> <li>Eliminates need for two costly protection diodes</li> </ul>	<b>Improving long term competitive cost position, integration and mass manufacturability</b>
<b>Robust against switching noise</b> <ul style="list-style-type: none"> <li>Floating drivers are able to handle large inductive voltage over- and undershoots</li> <li>Very high common mode transient immunity CMTI &gt; 150 V/ns</li> <li>Undervoltage lockout function for switch protection</li> </ul>	<b>Protection and safe operation</b> <ul style="list-style-type: none"> <li>Protection against shoot-through (EOS)</li> <li>Supports decoupling and limits the di/dt switching and ringing noise</li> <li>Reliable CT coreless transformer PWM signal chain</li> </ul>	<b>Improved end-product lifetime by improved safe operation of power switches</b>
<b>Output-to-output channel isolation</b> <ul style="list-style-type: none"> <li>Functional level galvanic isolation</li> </ul>	<b>Flexible assignment of any driver channel</b> <ul style="list-style-type: none"> <li>HS+LS, HS+HS, LS+LS or 2x I<sub>max</sub> on 1xHS</li> </ul>	<b>Lower EMI by ground isolation, driver proximity to MOSFETs or the use of 4-pin Kelvin source MOSFETs</b>
<b>Input-to-output channel isolation</b> <ul style="list-style-type: none"> <li>Functional galvanic isolation</li> </ul>	<b>Floating gate drive and regulatory safety</b> <ul style="list-style-type: none"> <li>Functional isolation for primary or secondary side control</li> </ul>	<b>Meeting requirements to build isolated AC-DC, DC-DC half-bridge topologies</b>



# EiceDRIVER™ 2EDF7275F and 2EDF7175F

Fast, robust, dual-channel, functional isolated MOSFET gate drivers with accurate and stable timing

## Device pin assignments

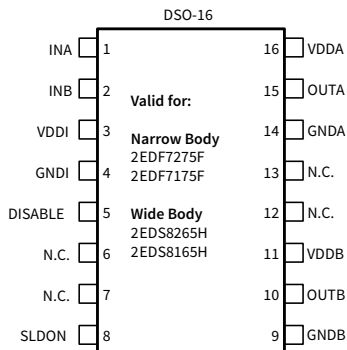

## Application diagram example

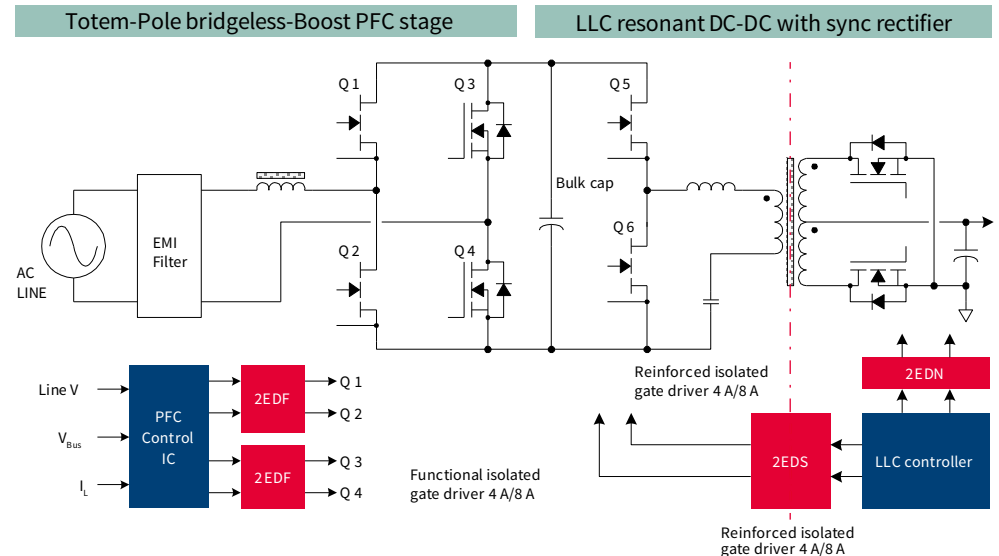

The 2EDF7275F input-to-outputs are functional isolated, which is used today in larger power PCB designs or when seeking to isolate the switching noise in the power loop from the microcontroller. With its >150 V/ns common mode noise immunity, the 2EDF is one of the most robust solutions available today for high-side, low-side half-bridge topologies with simple CMOS level PWM inputs. The high-side driver supply in the 2EDF can be implemented with a low cost bootstrap method.

The consistent performance and timing accuracy over temperature and production spread of the 2EDF family of isolated gate drivers makes them easy to use within a power stage or across multi-phase, multi-level designs and enables further efficiency gains in high performance power conversion applications.

## Product portfolio

Part number	Orderable part number (OPN)	Package	PWM Input type	Driver source/ Sink current	Gate driver UVLO	Input to output isolation				Dead-time control
						Isolation class	Rating	Surge testing	Safety certification	
2EDF7275F	2EDF7275FXUMA1	NB-DSO16 10x6mm	Dual mode (input A, input B)	4 A/8 A	4 V	Functional	1.5 kV <sub>peak</sub>	n.a.	n.a.	no
2EDF7175F	2EDF7175FXUMA1	NB-DSO16 10x6mm	Dual mode (input A, input B)	1 A/2 A	4 V	Functional	1.5 kV <sub>peak</sub>	n.a.	n.a.	no

For further device information, configurations and application notes, visit the 2EDi EiceDRIVER™ family under [www.infineon.com/2EDi](http://www.infineon.com/2EDi)

Published by  
Infineon Technologies Austria AG  
9500 Villach, Austria

© 2018 Infineon Technologies AG.  
All Rights Reserved.

### Please note!

THIS DOCUMENT IS FOR INFORMATION PURPOSES ONLY AND ANY INFORMATION GIVEN HEREIN SHALL IN NO EVENT BE REGARDED AS A WARRANTY, GUARANTEE OR DESCRIPTION OF ANY FUNCTIONALITY, CONDITIONS AND/OR QUALITY OF OUR PRODUCTS OR ANY SUITABILITY FOR A PARTICULAR PURPOSE. WITH REGARD TO THE TECHNICAL SPECIFICATIONS OF OUR PRODUCTS, WE KINDLY ASK YOU TO REFER TO THE RELEVANT PRODUCT DATA SHEETS PROVIDED BY US. OUR CUSTOMERS AND THEIR TECHNICAL DEPARTMENTS ARE REQUIRED TO EVALUATE THE SUITABILITY OF OUR PRODUCTS FOR THE INTENDED APPLICATION.

WE RESERVE THE RIGHT TO CHANGE THIS DOCUMENT AND/OR THE INFORMATION GIVEN HEREIN AT ANY TIME.

### Additional information

For further information on technologies, our products, the application of our products, delivery terms and conditions and/or prices, please contact your nearest Infineon Technologies office ([www.infineon.com](http://www.infineon.com)).

### Warnings

Due to technical requirements, our products may contain dangerous substances. For information on the types in question, please contact your nearest Infineon Technologies office.

Except as otherwise explicitly approved by us in a written document signed by authorized representatives of Infineon Technologies, our products may not be used in any life-endangering applications, including but not limited to medical, nuclear, military, life-critical or any other applications where a failure of the product or any consequences of the use thereof can result in personal injury.