

## N-channel 400 V, 3 Ω typ., 1.8 A SuperMESH3™ Power MOSFET in a SOT-223 package

Datasheet - production data

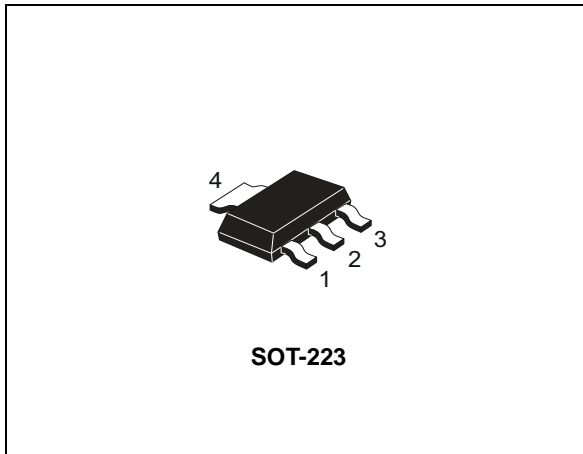
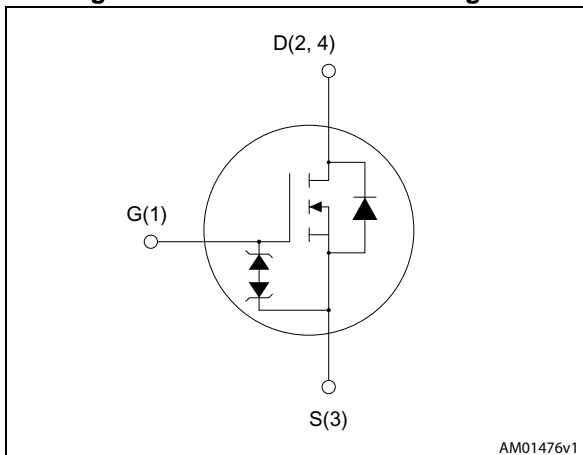

Figure 1. Internal schematic diagram



### Features

Order code	V <sub>DS</sub>	R <sub>DS(on)</sub> max	I <sub>D</sub>	P <sub>TOT</sub>
STN3N40K3	400V	3.4 Ω	1.8 A	3.3W

- 100% avalanche tested
- Extremely high dv/dt capability
- Gate charge minimized
- Very low intrinsic capacitance
- Improved diode reverse recovery characteristics
- Zener-protected

### Application

- Switching applications

### Description

This SuperMESH3™ Power MOSFET is the result of improvements applied to STMicroelectronics' SuperMESH™ technology, combined with a new optimized vertical structure. This device boasts an extremely low on-resistance, superior dynamic performance and high avalanche capability, rendering it suitable for the most demanding applications.

Table 1. Device summary

Order code	Marking	Package	Packaging
STN3N40K3	3N40K3	SOT-223	Tape and reel

# Contents

<b>1</b>	<b>Electrical ratings</b> .....	<b>3</b>
<b>2</b>	<b>Electrical characteristics</b> .....	<b>4</b>
	2.1 Electrical characteristics .....	6
<b>3</b>	<b>Test circuits</b> .....	<b>9</b>
<b>4</b>	<b>Package mechanical data</b> .....	<b>10</b>
<b>5</b>	<b>Revision history</b> .....	<b>13</b>

# 1 Electrical ratings

**Table 2. Absolute maximum ratings**

Symbol	Parameter	Value	Unit
$V_{DS}$	Drain source voltage	400	V
$V_{GS}$	Gate-source voltage	$\pm 30$	V
$I_D$	Drain current continuous $T_C = 25\text{ }^\circ\text{C}$	1.8 <sup>(1)</sup>	A
$I_D$	Drain current continuous $T_C = 100\text{ }^\circ\text{C}$	1 <sup>(1)</sup>	A
$I_{DM}$ <sup>(2)</sup>	Drain current pulsed	7.2	A
$I_{AR}$ <sup>(3)</sup>	Avalanche current, repetitive or not repetitive	0.6	A
$E_{AS}$ <sup>(4)</sup>	Single pulse avalanche energy	45	mJ
$P_{TOT}$	Total dissipation at $T_{amb} = 25\text{ }^\circ\text{C}$	3.3	W
$dv/dt$ <sup>(5)</sup>	Peak diode recovery voltage slope	12	V/ns
$E_{SD}$	Gate-source human body model ( $R = 1.5\text{ k}\Omega$ , $C = 100\text{ pF}$ )	1	kV
$T_j$ $T_{stg}$	Operating junction temperature Storage temperature	-55 to 150	$^\circ\text{C}$

1. Drain current limited by maximum junction temperature.
2. Pulse width limited by safe operating area.
3. Pulse width limited by  $T_{Jmax}$ .
4. Starting  $T_j = 25\text{ }^\circ\text{C}$ ,  $I_D = I_{AR}$ ,  $V_{DD} = 50\text{ V}$ .
5.  $I_{sd} \leq 1.8\text{ A}$ ,  $di/dt \leq 400\text{ A}/\mu\text{s}$ ,  $V_{DD} \leq 80\% V_{(BR)DSS}$ .

**Table 3. Thermal data**

Symbol	Parameter	Value	Unit
$R_{thj-amb}$ <sup>(1)</sup>	Thermal resistance junction-amb max.	37.9	$^\circ\text{C}/\text{W}$

1. When mounted on FR-4 board of 1 inch<sup>2</sup>, 2oz Cu,  $t < 30\text{ s}$

## 2 Electrical characteristics

(T<sub>case</sub> = 25 °C unless otherwise specified)

**Table 4. On /off states**

Symbol	Parameter	Test conditions	Min.	Typ.	Max.	Unit
V <sub>(BR)DSS</sub>	Drain-source breakdown voltage	I <sub>D</sub> = 1 mA, V <sub>GS</sub> = 0	400			V
I <sub>DSS</sub>	Zero gate voltage drain current	V <sub>GS</sub> = 0, V <sub>DS</sub> = 400 V			1	μA
		V <sub>GS</sub> = 0, V <sub>DS</sub> = 400 V, T <sub>C</sub> = 125 °C			50	μA
I <sub>GSS</sub>	Gate-body leakage current	V <sub>DS</sub> = 0, V <sub>GS</sub> = ± 20 V			±10	μA
V <sub>GS(th)</sub>	Gate threshold voltage	V <sub>GS</sub> = V <sub>DS</sub> , I <sub>D</sub> = 50 μA	3	3.75	4.5	V
R <sub>DS(on)</sub>	Static drain-source on resistance	V <sub>GS</sub> = 10 V, I <sub>D</sub> = 0.6 A		3.1	3.4	Ω

**Table 5. Dynamic**

Symbol	Parameter	Test conditions	Min.	Typ.	Max.	Unit
C <sub>iss</sub>	Input capacitance	V <sub>DS</sub> = 50 V, f = 1 MHz, V <sub>GS</sub> = 0	-	165	-	pF
C <sub>oss</sub>	Output capacitance		-	17	-	pF
C <sub>rss</sub>	Reverse transfer capacitance		-	3	-	pF
C <sub>oss(er)</sub> <sup>(1)</sup>	Equivalent output capacitance energy related	V <sub>DS</sub> = 0 to 320 V, V <sub>GS</sub> = 0	-	9	-	pF
C <sub>oss(tr)</sub> <sup>(2)</sup>	Equivalent output capacitance time related		-	14	-	pF
R <sub>g</sub>	Intrinsic gate resistance	f=1 MHz open drain	-	10	-	Ω
Q <sub>g</sub>	Total gate charge	V <sub>DD</sub> = 320 V, I <sub>D</sub> = 1.8 A, V <sub>GS</sub> = 10 V (see <a href="#">Figure 18</a> )	-	11	-	nC
Q <sub>gs</sub>	Gate-source charge		-	2	-	nC
Q <sub>gd</sub>	Gate-drain charge		-	7	-	nC

1. Is defined as a constant equivalent capacitance giving the same charging time as C<sub>oss</sub> when V<sub>DS</sub> increases from 0 to 80% V<sub>DSS</sub>
2. Is defined as a constant equivalent capacitance giving the same storage energy as C<sub>oss</sub> when V<sub>DS</sub> increases from 0 to 80% V<sub>DSS</sub>

Table 6. Switching times

Symbol	Parameter	Test conditions	Min.	Typ.	Max	Unit
$t_{d(on)}$	Turn on delay time	$V_{DD} = 200\text{ V}$ , $I_D = 0.6$ , $R_G = 4.7\ \Omega$ , $V_{GS} = 10\text{ V}$ (see <a href="#">Figure 17</a> )	-	7	-	ns
$t_r$	Rise time		-	8	-	ns
$t_{d(off)}$	Turn off delay time		-	18	-	ns
$t_f$	Fall time		-	14	-	ns

Table 7. Source drain diode

Symbol	Parameter	Test conditions	Min.	Typ.	Max.	Unit
$I_{SD}$	Source-drain current		-		1.8	A
$I_{SDM}^{(1)}$	Source-drain current (pulsed)		-		7.2	A
$V_{SD}^{(2)}$	Forward on voltage	$I_{SD} = 0.6\text{ A}$ , $V_{GS} = 0$	-		1.5	V
$t_{rr}$	Reverse recovery time	$I_{SD} = 1.8\text{ A}$ , $di/dt = 100\text{ A}/\mu\text{s}$ $V_{DD} = 60\text{ V}$ (see <a href="#">Figure 20</a> )	-	145		ns
$Q_r$	Reverse recovery charge		-	490		nC
$I_{RRM}$	Reverse recovery current		-	7		A
$t_{rr}$	Reverse recovery time	$I_{SD} = 1.8\text{ A}$ , $di/dt = 100\text{ A}/\mu\text{s}$ $V_{DD} = 60\text{ V}$ , $T_j = 150\text{ }^\circ\text{C}$ (see <a href="#">Figure 20</a> )	-	166		ns
$Q_{rr}$	Reverse recovery charge		-	580		nC
$I_{RRM}$	Reverse recovery current		-	7		A

1. Pulse width limited by safe operating area.
2. Pulsed: pulse duration = 300  $\mu\text{s}$ , duty cycle 1.5%

## 2.1 Electrical characteristics

Figure 2. Safe operating area

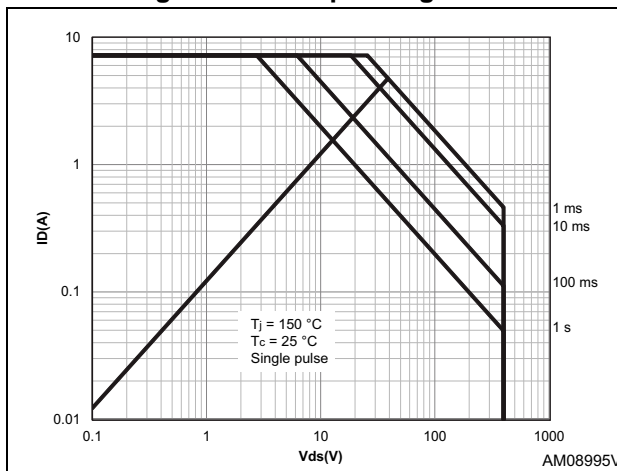

Figure 3. Thermal impedance

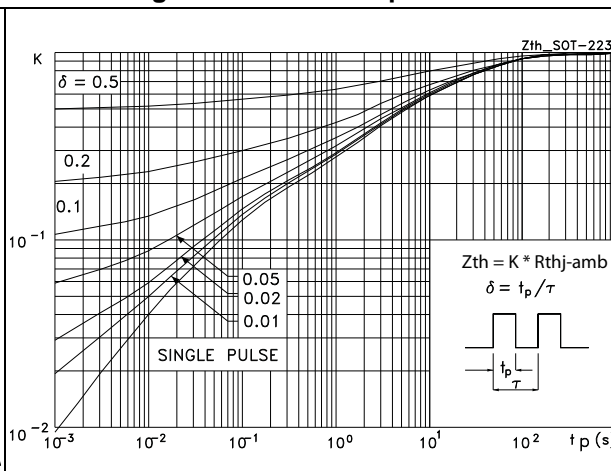

Figure 4. Output characteristics

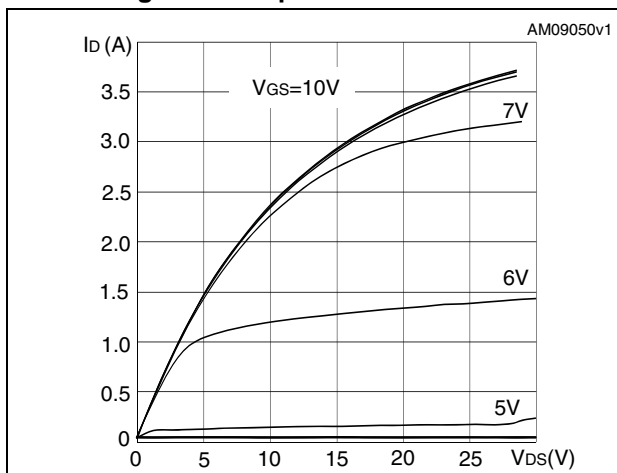

Figure 5. Transfer characteristics

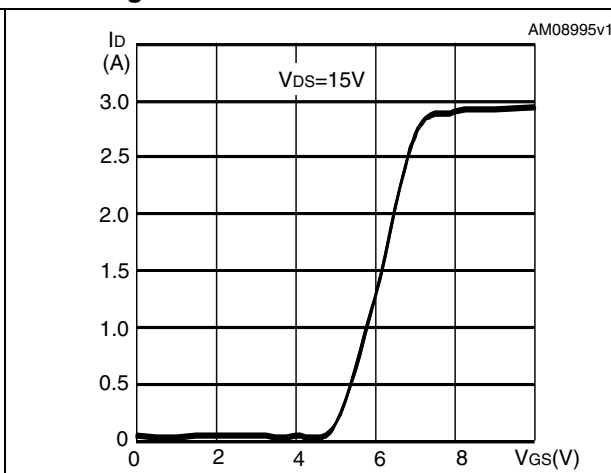

Figure 6. Gate charge vs gate-source voltage

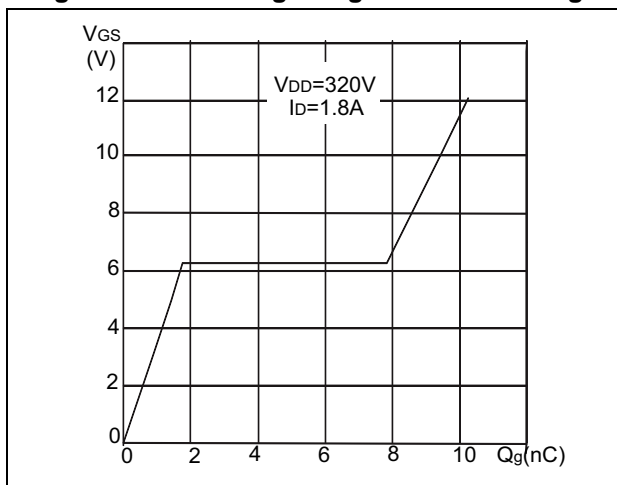

Figure 7. Static drain-source on resistance

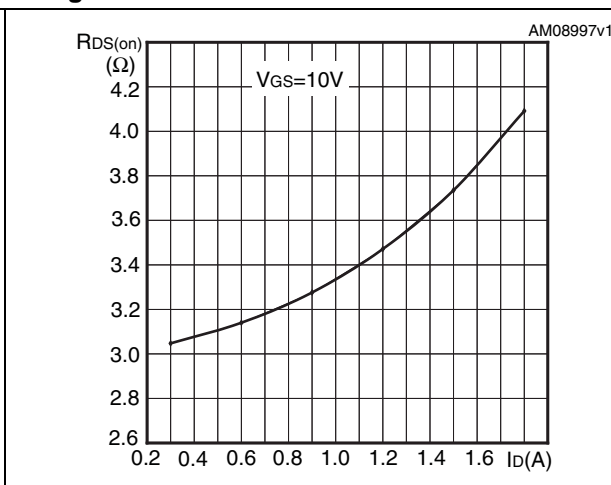

Figure 8. Capacitance variations

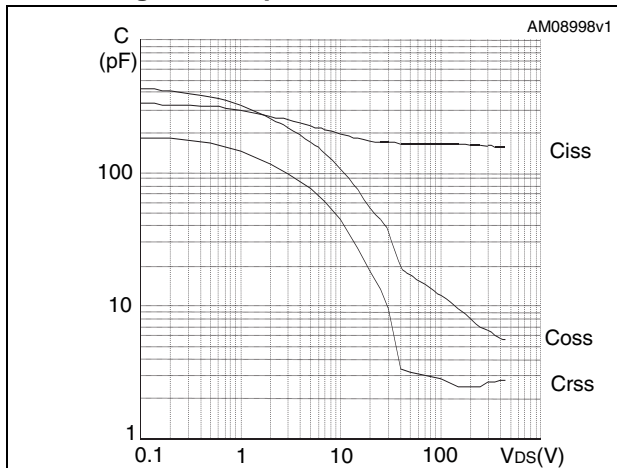

Figure 9. Output capacitance stored energy

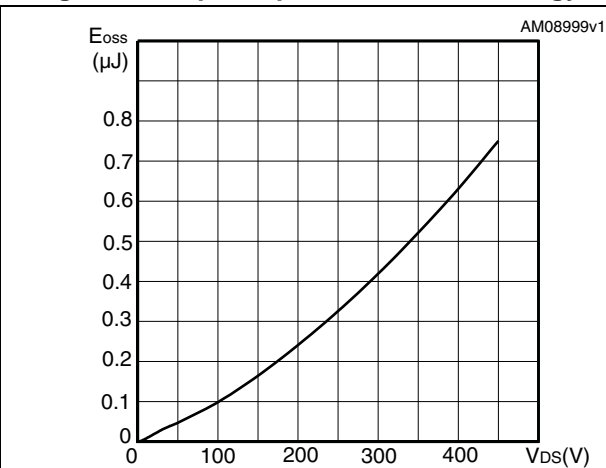

Figure 10. Normalized gate threshold voltage vs. temperature

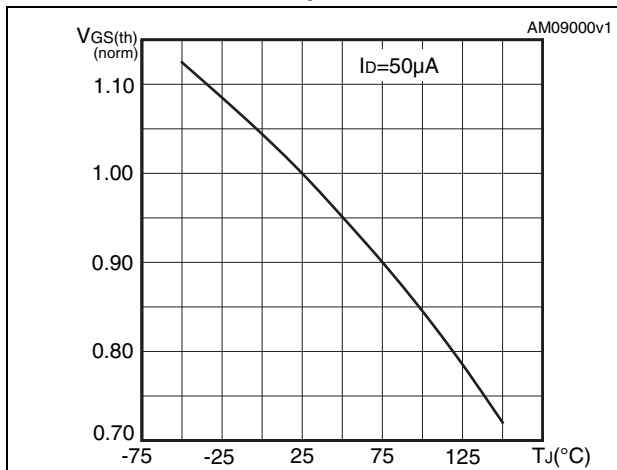

Figure 11. Normalized on resistance vs. temperature

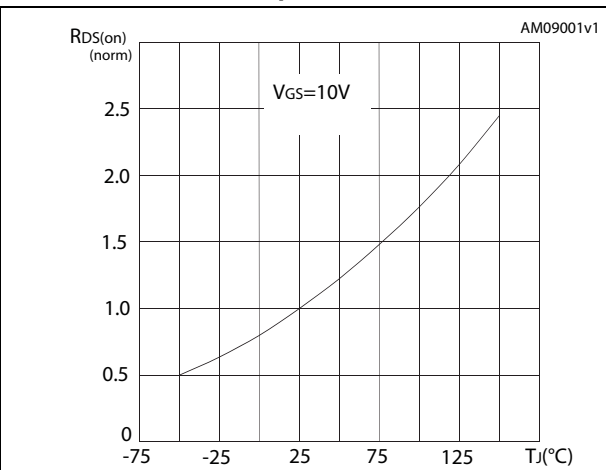

Figure 12. Source-drain diode forward characteristics

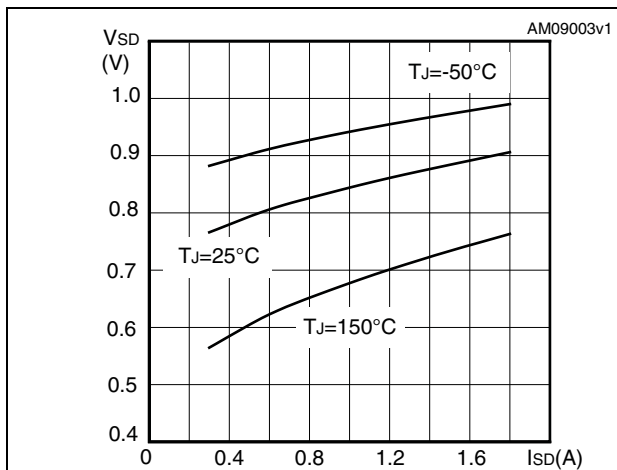

Figure 13. Normalized V(BR)DSS vs. temperature

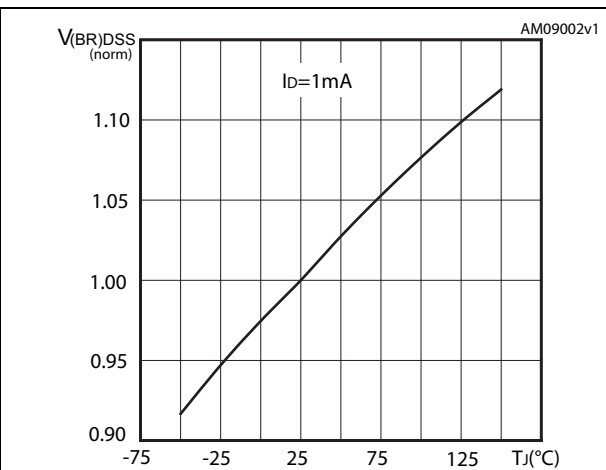
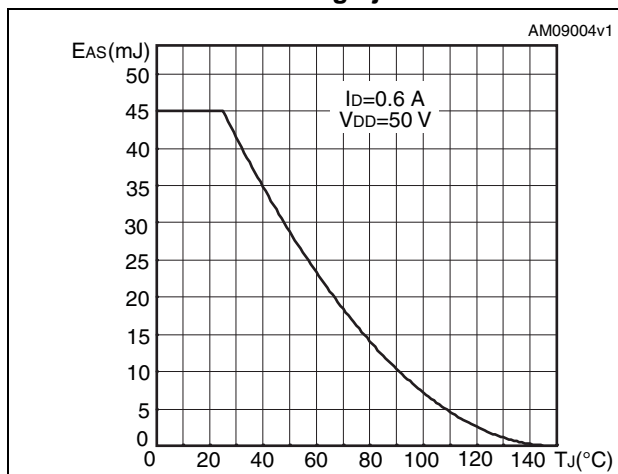

Figure 14. Maximum avalanche energy vs. starting Tj





### 3 Test circuits

Figure 15. Switching times test circuit for resistive load

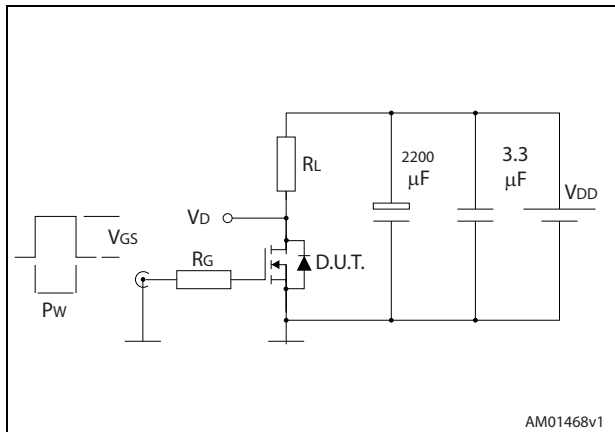

AM01468v1

Figure 16. Gate charge test circuit

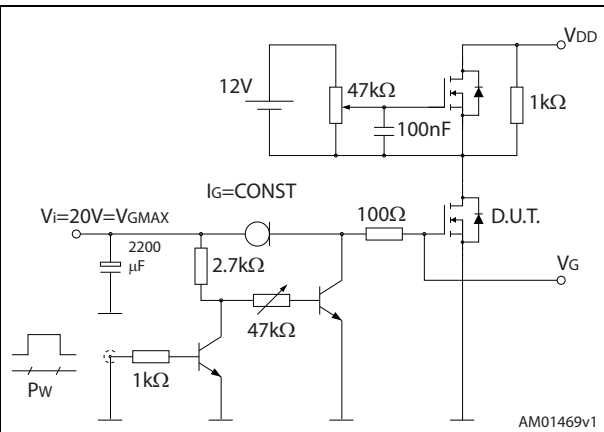

AM01469v1

Figure 17. Switching times test circuit for resistive load

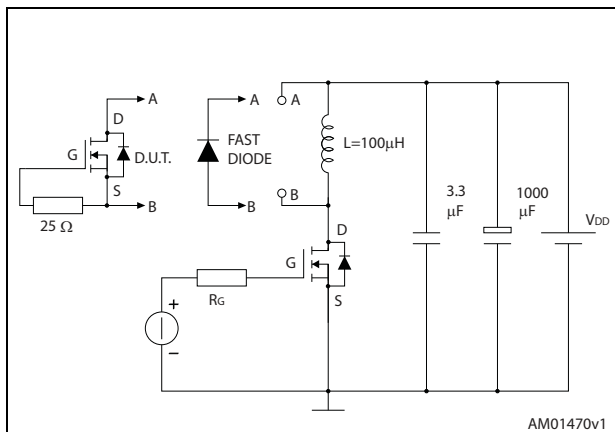

AM01470v1

Figure 18. Gate charge test circuit

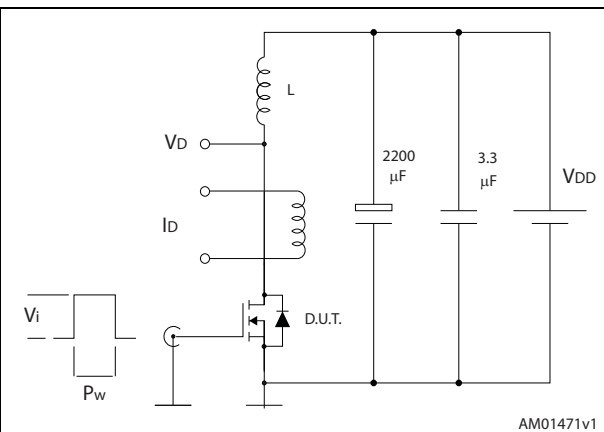

AM01471v1

Figure 19. Unclamped inductive waveform

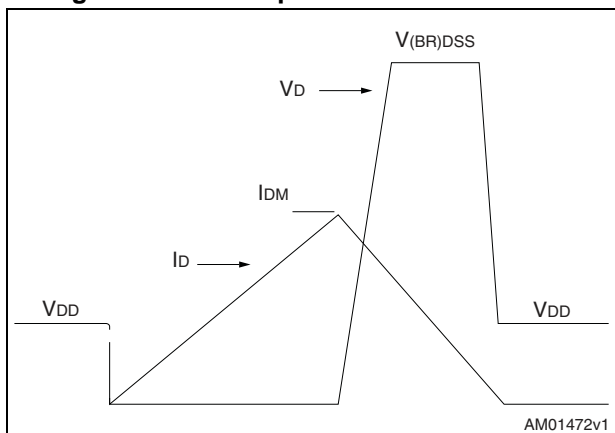

AM01472v1

Figure 20. Switching time waveform

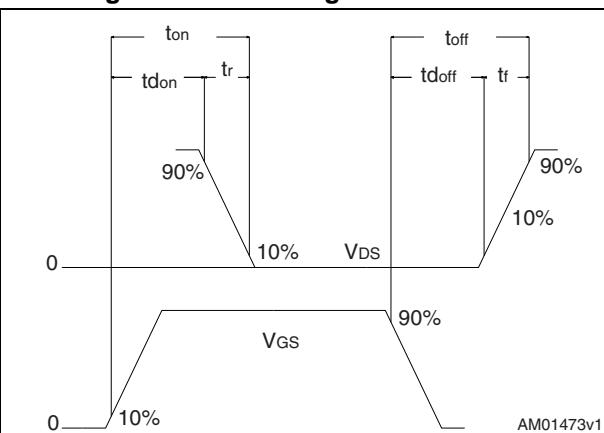

AM01473v1

## 4 Package mechanical data

In order to meet environmental requirements, ST offers these devices in different grades of ECOPACK<sup>®</sup> packages, depending on their level of environmental compliance. ECOPACK<sup>®</sup> specifications, grade definitions and product status are available at: [www.st.com](http://www.st.com). ECOPACK is an ST trademark.

Figure 21. SOT-223 mechanical data drawing

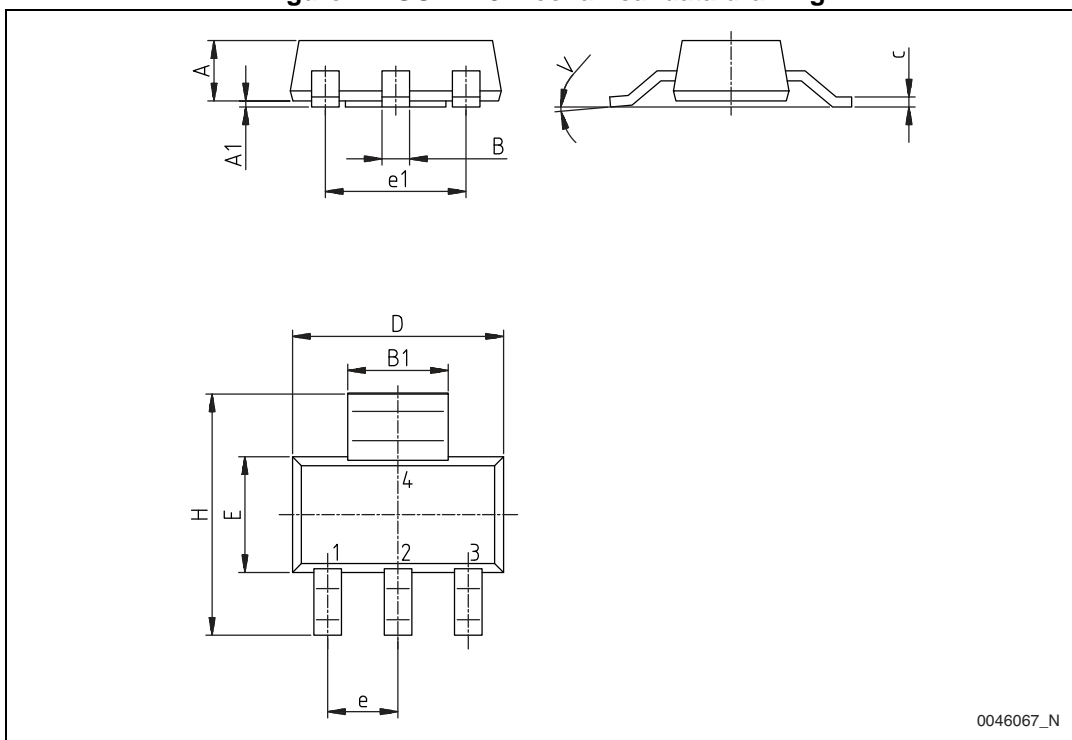

0046067\_N

Table 8. SOT-223 mechanical data

Dim.	mm		
	Min.	Typ.	Max.
A			1.80
A1	0.02		0.10
B	0.60	0.70	0.85
B1	2.9	3.0	3.15
c	0.24	0.26	0.35
D	6.30	6.50	6.70
e		2.30	6.70
e1		4.60	
E	3.30	3.50	3.70
H	6.70	7.0	7.30
V			10°

Figure 22. SOT-223 footprint

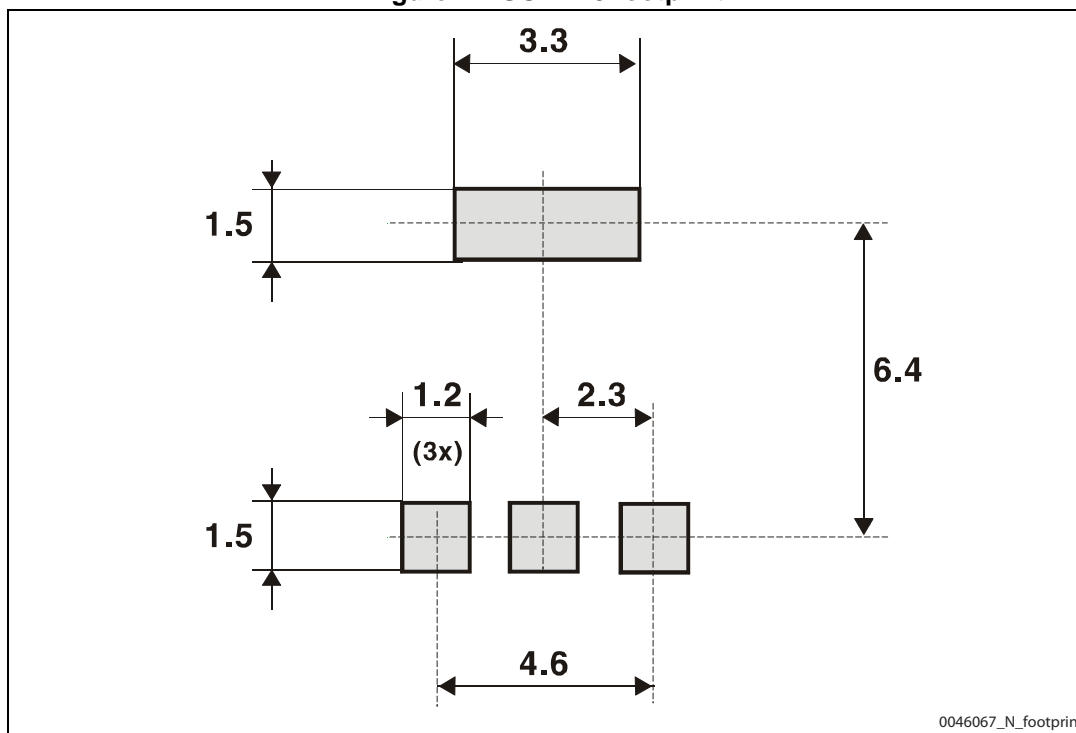

## 5 Revision history

Table 9. Document revision history

Date	Revision	Changes
29-Jun-2010	1	First release.
08-Apr-2011	2	Document status promoted from preliminary data to datasheet.
06-Jun-2014	3	Updated silhouette, features and <i>Figure 1: Internal schematic diagram</i> in cover page. Updated <i>Table 2: Absolute maximum ratings</i> , <i>Table 3: Thermal data</i> , and <i>Table 4: On /off states</i> . Updated <i>Figure 2: Safe operating area</i> and <i>Figure 6: Gate charge vs gate-source voltage</i> . Updated <i>Section 4: Package mechanical data</i> . Minor text changes.

**Please Read Carefully:**

Information in this document is provided solely in connection with ST products. STMicroelectronics NV and its subsidiaries ("ST") reserve the right to make changes, corrections, modifications or improvements, to this document, and the products and services described herein at any time, without notice.

All ST products are sold pursuant to ST's terms and conditions of sale.

Purchasers are solely responsible for the choice, selection and use of the ST products and services described herein, and ST assumes no liability whatsoever relating to the choice, selection or use of the ST products and services described herein.

No license, express or implied, by estoppel or otherwise, to any intellectual property rights is granted under this document. If any part of this document refers to any third party products or services it shall not be deemed a license grant by ST for the use of such third party products or services, or any intellectual property contained therein or considered as a warranty covering the use in any manner whatsoever of such third party products or services or any intellectual property contained therein.

**UNLESS OTHERWISE SET FORTH IN ST'S TERMS AND CONDITIONS OF SALE ST DISCLAIMS ANY EXPRESS OR IMPLIED WARRANTY WITH RESPECT TO THE USE AND/OR SALE OF ST PRODUCTS INCLUDING WITHOUT LIMITATION IMPLIED WARRANTIES OF MERCHANTABILITY, FITNESS FOR A PARTICULAR PURPOSE (AND THEIR EQUIVALENTS UNDER THE LAWS OF ANY JURISDICTION), OR INFRINGEMENT OF ANY PATENT, COPYRIGHT OR OTHER INTELLECTUAL PROPERTY RIGHT.**

**ST PRODUCTS ARE NOT DESIGNED OR AUTHORIZED FOR USE IN: (A) SAFETY CRITICAL APPLICATIONS SUCH AS LIFE SUPPORTING, ACTIVE IMPLANTED DEVICES OR SYSTEMS WITH PRODUCT FUNCTIONAL SAFETY REQUIREMENTS; (B) AERONAUTIC APPLICATIONS; (C) AUTOMOTIVE APPLICATIONS OR ENVIRONMENTS, AND/OR (D) AEROSPACE APPLICATIONS OR ENVIRONMENTS. WHERE ST PRODUCTS ARE NOT DESIGNED FOR SUCH USE, THE PURCHASER SHALL USE PRODUCTS AT PURCHASER'S SOLE RISK, EVEN IF ST HAS BEEN INFORMED IN WRITING OF SUCH USAGE, UNLESS A PRODUCT IS EXPRESSLY DESIGNATED BY ST AS BEING INTENDED FOR "AUTOMOTIVE, AUTOMOTIVE SAFETY OR MEDICAL" INDUSTRY DOMAINS ACCORDING TO ST PRODUCT DESIGN SPECIFICATIONS. PRODUCTS FORMALLY ESCC, QML OR JAN QUALIFIED ARE DEEMED SUITABLE FOR USE IN AEROSPACE BY THE CORRESPONDING GOVERNMENTAL AGENCY.**

Resale of ST products with provisions different from the statements and/or technical features set forth in this document shall immediately void any warranty granted by ST for the ST product or service described herein and shall not create or extend in any manner whatsoever, any liability of ST.

ST and the ST logo are trademarks or registered trademarks of ST in various countries.

Information in this document supersedes and replaces all information previously supplied.

The ST logo is a registered trademark of STMicroelectronics. All other names are the property of their respective owners.

© 2014 STMicroelectronics - All rights reserved

STMicroelectronics group of companies

Australia - Belgium - Brazil - Canada - China - Czech Republic - Finland - France - Germany - Hong Kong - India - Israel - Italy - Japan - Malaysia - Malta - Morocco - Philippines - Singapore - Spain - Sweden - Switzerland - United Kingdom - United States of America

[www.st.com](http://www.st.com)