

PART NUMBER	CENTER PIN/JACK SIZE	MATING POWER PLUG
L712RAS	0.10 [2.5 mm]	761KS12, 761KS15, 761KS17
L722RAS	0.080 [2.0 mm]	S761KS12, S761KS15, S761KS17 767KS12, 767KS15, 767KS17

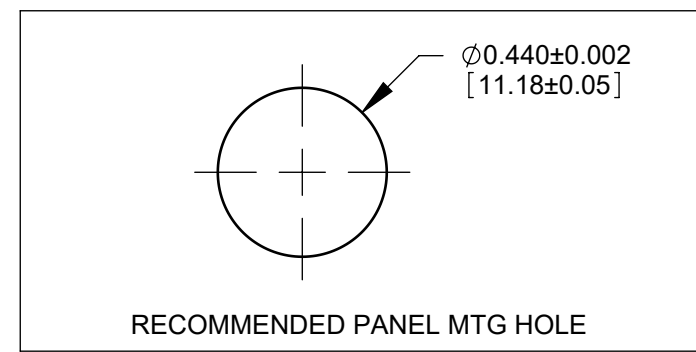

- NOTES:
- FOR HAND INSERTION USE SPACING 0.130 [3.30]
FOR AUTOMATED INSERTION USE SPACING 0.135 [3.43]
 - DIMENSIONS SHOWN FOR REFERENCE ONLY.
 - HEX NUT, FLAT WASHER, AND PANEL O-RING SUPPLIED UNASSEMBLED
 - MATERIAL:
HOUSINGS, HEX NUT - COPPER ALLOY, NICKEL PLATED
INSULATOR HOUSING - THERMOPLASTIC
O-RINGS - THERMOPLASTIC RUBBER, LUBRICATED WITH SYNTHETIC GREASE
TERMINAL INSULATORS - PHENOLIC
FLAT WASHER - STEEL, NICKEL PLATED
PIN, SPRING, TERMINALS - COPPER ALLOY, SILVER PLATED
 - IT IS RECOMMENDED THAT THE JACK MOUNTING NUT BE TIGHTENED SNUG BY HAND BEFORE APPLYING A FINAL TIGHTENING TORQUE OF 8-10 LB-IN USING HAND TOOLS ONLY. POWER DRIVER OR IMPACT DRIVERS ARE NOT RECOMMENDED.
 - THIS PRODUCT IS RoHS COMPLIANT

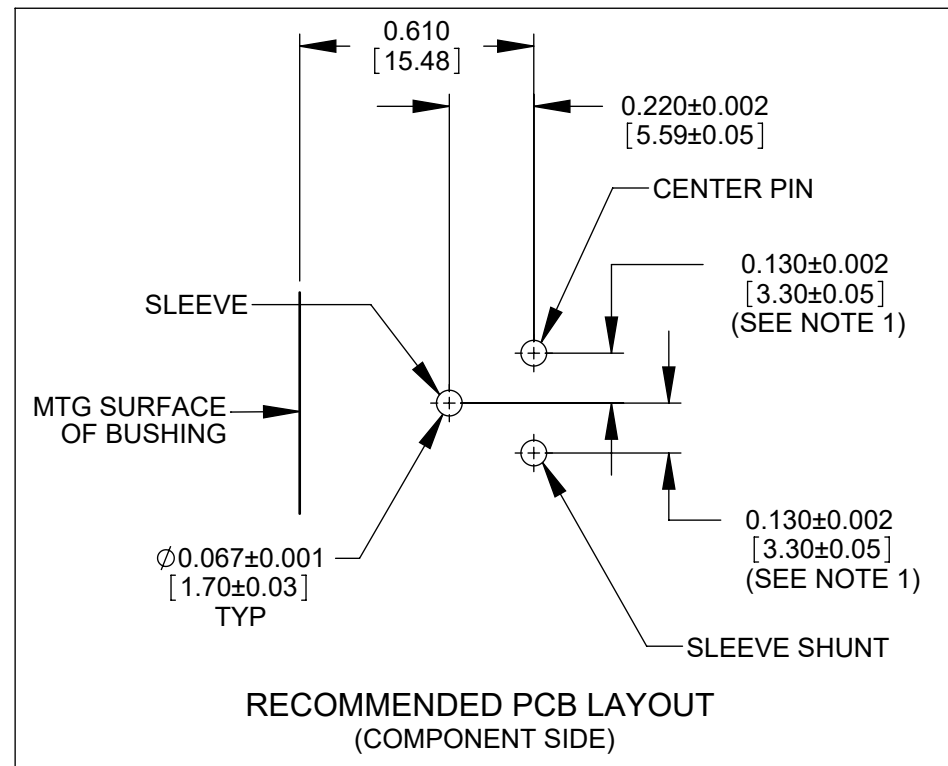
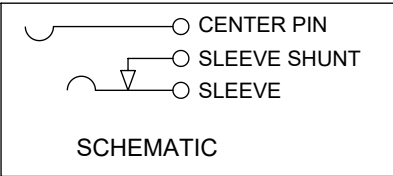

CUSTOMER DRAWING

REV	ECO NUMBER	DATE	BY	APVD
G	28397	06-11-21	PC	TJK
F	28350	12-22-20	PC	TJK
E	28220	11-08-19	PC	TJK
D	27229	12-4-13	TO	TJK
C	27151	5-22-13	TO	TJK
B	27029	10/01/12	BL	TJK
A	26591	8/6/10	RS	TJK

UNLESS OTHERWISE SPECIFIED

1. ALL DIMENSIONS IN INCHES [mm]
- TWO PLACE DECIMALS ±0.02 [0.5]
- THREE PLACE DECIMALS ±0.005 [0.13]

DO NOT SCALE DRAWING

THIS DRAWING DESCRIBES A DESIGN CONSIDERED PROPRIETARY IN NATURE, DEVELOPED AND MANUFACTURED BY SWITCHCRAFT INC. AND IS RELEASED ON A CONFIDENTIAL BASIS FOR IDENTIFICATION PURPOSES ONLY.									
SIZE	WIDTH	MULT	LBS/M	TEMPER					
FINISH SPEC No.					MATERIAL SPEC No.				
FIRST USED ON			SCALE 2:1						
DATE DRAWN	BY	CHKD	APVD						
7/23/09	PNK	RS	TJK						
NAME			SEALED POWER JACKS RIGHT ANGLE PC, RoHS		PART No.		REV		
					L712RAS, L722RAS		G		