

2.4MHz, 3A x 2ch Synchronous Buck Converter for POL

FEATURES

- 2ch Synchronous Rectification
- Current Mode Control
- Operating Voltage Range 2.7V to 5.5V
- Switching Current 3.3A min.
- Adjustable Oscillating Frequency 100kHz to 2.4MHz
- External Clock Synchronization
- PWM Control
- Maximum Duty Cycle 100%
- High Efficiency at Light Loads (Selectable)
- Low Iq at Sleep Mode 500μA typ.
- Anti-Phase switching
- External Compensation Circuit
- Correspond to Ceramic Capacitor (MLCC)
- Adjustable Soft Start Function
- UVLO (Under Voltage Lockout)
- Over Current Protection (Hiccup type)
- Thermal Shutdown Protection
- Power Good Function
- Standby Function
- Package Outline EQFN24-LE

GENERAL DESCRIPTION

The NJW4110 is a synchronous 2ch buck converter with 3A MOSFET. The switching oscillating frequency is adjustable from 100kHz to 2,4MHz. Also, it can be synchronized with external clock. The NJW4110 can be selected PFM to ensure high efficiency at light load.

The NJW4110 has a single oscillator and operates an Ant-Phase switching to reduce input ripple current

Each buck converters have independent enable functions, soft start functions, over current protection and power good functions. The protection functions are UVLO and thermal shutdown circuit.

It is suitable for power supply circuit of SoC, DSP, DDR memory and so on that need fast transient response.

APPLICATION

- Power supply for SoC, ASIC, DDR and the others

TYPICAL APPLICATION

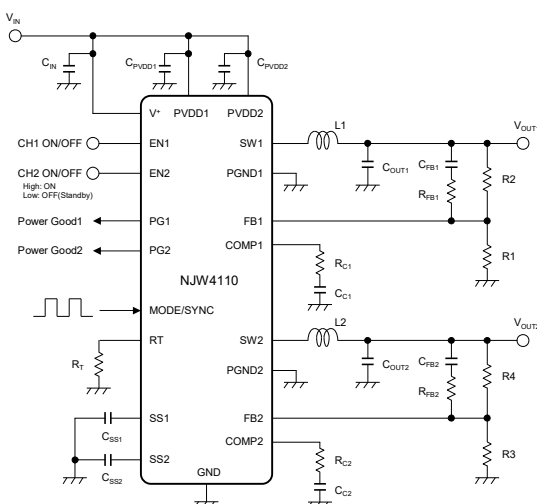

■BLOCK DIAGRAM

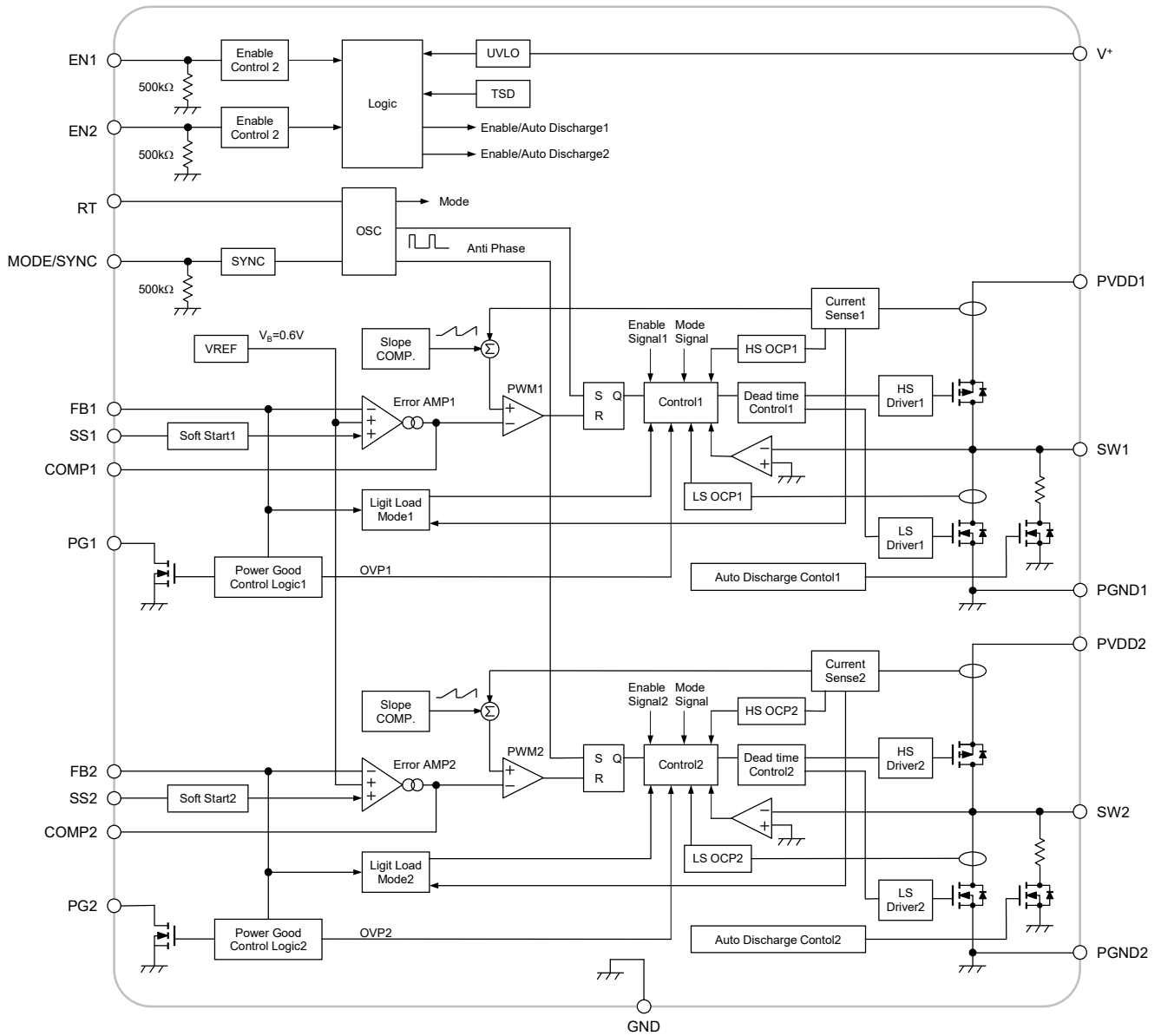

■PIN CONFIGURATION

EQFN24-LE

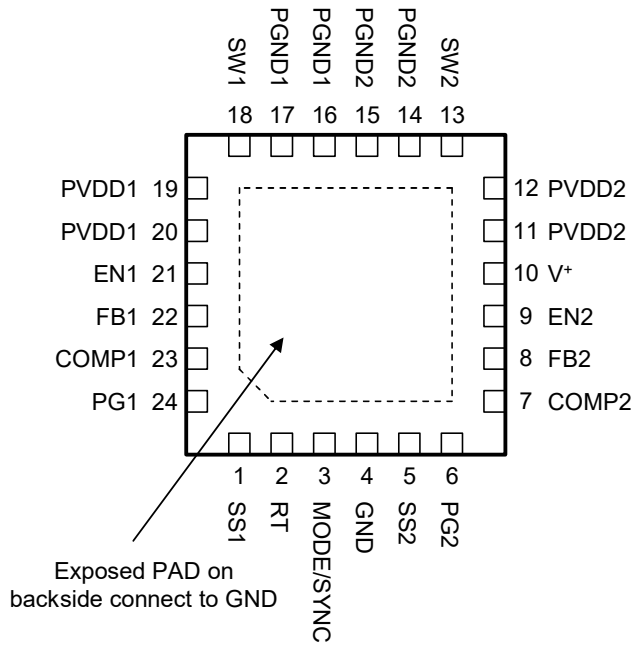

Note) Exposed Pad on backside should be connected to ground and soldered to PCB.

PIN NO.	SYMBOL	DESCRIPTION
1	SS1	Soft start setting of Ch.1
2	RT	Oscillating frequency setting
3	MODE/SYNC	Light Load mode select and external clock synchronization
4	GND	Signal ground
5	SS2	Soft Start setting of Ch.2
6	PG2	Power Good output of Ch.2
7	COMP2	Error Amplifier output of Ch.2
8	FB2	Feedback input of Ch.2
9	EN2	Enable control of Ch.2
10	V ⁺	Power supply for IC Control
11	PVDD2	Power supply of Ch.2
12	PVDD2	
13	SW2	Switch output of Ch.2
14	PGND2	Power ground of Ch.2
15	PGND2	
16	PGND1	Power ground of Ch.1
17	PGND1	
18	SW1	Switch output of Ch.1
19	PVDD1	Power supply of Ch.1
20	PVDD1	
21	EN1	Enable control of Ch.1
22	FB1	Feedback input of Ch.1
23	COMP1	Error Amplifier output of Ch.1
24	PG1	Power Good output of Ch.1

■PRODUCT NAME INFORMATION

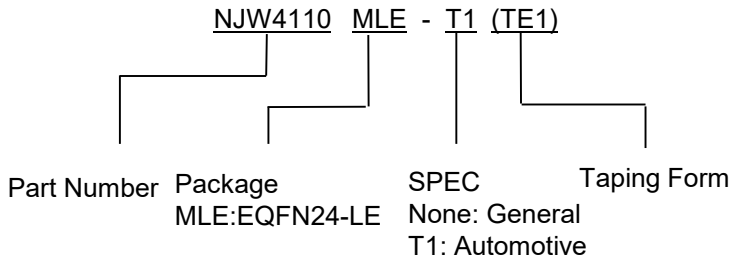

■ORDERING INFORMATION

PRODUCT NAME	PACKAGE OUTLINE	AUTO MOTIVE	RoHS	HALOGEN-FREE	TERMINAL FINISH	MARKING	WEIGHT (mg)	MOQ(pcs)
NJW4110MLE (TE1)	EQFN24-LE		yes	yes	Sn2Bi	4110	31	1,000
NJW4110MLE-T1 (TE1)	EQFN24-LE	yes	yes	yes	Sn2Bi	4110T1	31	1,000

This data sheet is applied to "NJW4110MLE".

Please refer to each data sheet for other versions.

■ABSOLUTE MAXIMUM RATINGS

PARAMETER	SYMBOL	RATINGS	UNIT
Supply Voltage	V^+	-0.3 to +7	V
PVDD1,2 pin Voltage	$PV_{DD1,2}$	-0.3 to +7	V
SW1,2 pin Voltage	$V_{SW1,2}$	-0.3 to +7	V
EN1,2 pin Voltage	$V_{EN1,2}$	-0.3 to +7	V
FB1,2 pin Voltage	$V_{FB1,2}$	-0.3 to +7	V
PG1,2 pin Voltage	$V_{PG1,2}$	-0.3 to +7	V
MODE/SYNC pin Voltage	$V_{MODE/SYNC}$	-0.3 to +7	V
Power Dissipation($T_a=25^{\circ}\text{C}$) EQFN24-LE	P_D	(2-layer / 4-layer) 1,000 ⁽¹⁾ / 2,800 ⁽²⁾	mW
Junction Temperature	T_j	-40 to +150	$^{\circ}\text{C}$
Operating Temperature	T_{opr}	-40 to +125	$^{\circ}\text{C}$
Storage Temperature	T_{stg}	-50 to +150	$^{\circ}\text{C}$

(1): Mounted on glass epoxy board. (101.5×114.5×1.6mm: based on EIA/JEDEC standard, 2Layers FR-4, with Exposed Pad)

(2): Mounted on glass epoxy board. (101.5×114.5×1.6mm: based on EIA/JEDEC standard, 4Layers FR-4, with Exposed Pad)

(For 4Layers: Applying 99.5×99.5mm inner Cu area and thermal via holes to a board based on JEDEC standard JESD51-5)

■RECOMMENDED OPERATING CONDITIONS

PARAMETER	SYMBOL	RATINGS	UNIT
Supply Voltage	V^+	2.7 to 5.5	V
PVDD1,2 pin Voltage	$PV_{DD1,2}$	Up to 5.5	V
PG1,2 pin Voltage	$V_{PG1,2}$	0 to 5.5	V
Timing Resistor	R_T	2.26 to 84.5	$\text{k}\Omega$
Oscillating Frequency	f_{osc}	100 to 2,400	kHz
External Clock Input	f_{sync}	$f_{osc} \times 0.9$ to $f_{osc} \times 1.9$ (Minimum 200kHz, Maximum 2,800kHz)	kHz

■ ELECTRICAL CHARACTERISTICS

(Unless otherwise noted, $PV_{DD}=V^+=V_{EN}=3.3V$, $PGND=GND$, $R_T=6.8k\Omega$, Common to CH1 and CH2, $T_a=25^\circ C$)

PARAMETER	SYMBOL	TEST CONDITION	MIN.	TYP.	MAX.	UNIT
-----------	--------	----------------	------	------	------	------

Under Voltage Lockout Block

ON Threshold Voltage	V_{T_ON}	$V^+=L \rightarrow H$	2.5	2.6	2.7	V
OFF Threshold Voltage	V_{T_OFF}	$V^+=H \rightarrow L$	2.4	2.5	2.6	V
Hysteresis Voltage	V_{HYS}		80	100	–	mV

Soft Start Block

Charge Current	I_{CHG}		6	8	10	μA
----------------	-----------	--	---	---	----	---------

Oscillator Block

Oscillating Frequency 1	f_{OSC1}	$R_T=26.1 k\Omega$	255	300	345	kHz
Oscillating Frequency 2	f_{OSC2}	$R_T=6.8 k\Omega$	850	1,000	1,150	kHz
Oscillating Frequency 3	f_{OSC3}	$R_T=2.26k\Omega$	2,160	2,400	2,640	kHz

Error Amplifier Block

Reference Voltage	V_B		-1.0%	0.6	+1.0%	V
Input Bias Current	I_B		-0.1	–	0.1	μA
Error Amplifier Transconductance	gm		–	450	–	$\mu A/V$
Error Amplifier Gain	A_V		–	1,400	–	–
Output Source Current	I_{OM+}		33	45	60	μA
Output Sink Current	I_{OM-}		33	45	60	μA

PWM Compare Block

Maximum Duty Cycle	M_{AXDUTY}	$V_{FB}=0.5V$	100	–	–	%
Minimum OFF Time	$t_{OFF-min}$		–	80	–	ns
Minimum ON Time	t_{ON-min}		–	80	–	ns

■ ELECTRICAL CHARACTERISTICS (CONTINUED)

 (Unless otherwise noted, $PV_{DD}=V^+=V_{EN}=3.3V$, $PGND=GND$, $R_T=6.8k\Omega$, Common to CH1 and CH2, $T_a=25^\circ C$)

PARAMETER	SYMBOL	TEST CONDITION	MIN.	TYP.	MAX.	UNIT
-----------	--------	----------------	------	------	------	------

OCP Block

COOL DOWN Time	t_{COOL}		–	120	–	ms
----------------	------------	--	---	-----	---	----

Output Block

High-side SW ON Resistance	R_{ONH}	$I_{SW}=3A$	–	80	120	$m\Omega$
Low-side SW ON Resistance	R_{ONL}	$I_{SW}=3A$	–	60	100	$m\Omega$
High-side Switching Current Limit	I_{LIMH}		3.3	4.5	6	A
Low-side Switching Current Limit	I_{LIML}	SW to PGND	2.3	3.5	5.5	A
Auto Discharge Resistance	$R_{AUTODIS}$	$I_{SW}=10mA$	–	60	100	Ω
High-side SW Leak Current	I_{LEAKH}	$PV_{DD} - V_{SW}=5.5V$	–	–	5	μA
Low-side SW Leak Current	I_{LEAKL}	$V_{SW} - PGND=5.5V$	–	–	1	μA

Enable Control Block

EN pin High Threshold Voltage	V_{THH_EN}	$V_{EN}=L \rightarrow H$	1.0	–	5.5	V
EN pin Low Threshold Voltage	V_{THL_EN}	$V_{EN}=H \rightarrow L$	0	–	0.4	V
EN pin Input Bias Current	I_{EN}	$V_{EN}=5.5V$	–	10	15	μA

MODE Control / Sync Block

MODE/SYNC pin High Threshold Voltage	$V_{THH_MODE/SYNC}$	$V_{MODE/SYNC}=L \rightarrow H$	1.2	–	5.5	V
MODE/SYNC pin Low Threshold Voltage	$V_{THL_MODE/SYNC}$	$V_{MODE/SYNC}=H \rightarrow L$	0	–	0.4	V
MODE/SYNC pin Input Bias Current	$I_{MODE/SYNC}$	$V_{MODE/SYNC}=5.5V$	–	10	15	μA

■ ELECTRICAL CHARACTERISTICS (CONTINUED)

 (Unless otherwise noted, $PV_{DD}=V^+=V_{EN}=3.3V$, $PGND=GND$, $R_T=6.8k\Omega$, Common to CH1 and CH2, $T_a=25^\circ C$)

PARAMETER	SYMBOL	TEST CONDITION	MIN.	TYP.	MAX.	UNIT
Power Good Block						
High Level Detection Voltage	V_{THH_PG}	Measured at FB pin, Rising	0.63	0.642	0.654	V
Low Level Detection Voltage	V_{THL_PG}	Measured at FB pin, Falling	0.558	0.57	0.582	V
Hysteresis Region	V_{HYS_PG}		—	12	—	mV
Power Good ON Resistance	R_{ON_PG}	$I_{PG}=10mA$	—	100	—	Ω
Leak Current at OFF State	I_{LEAK_PG}	$V_{PG}=5.5V$	—	—	0.1	μA

General Characteristics

Quiescent Current1 (PWM Mode)	I_{DD1}	R_L = no load, Not Switching, $V_{MODE/SYNC}=H$, Both channel operation	—	3.8	5.0	mA
Quiescent Current2 (Light Load Mode)	I_{DD2}	R_L = no load, Not Switching, $V_{MODE/SYNC}=L$, Both channel operation	—	500	750	μA
Standby Current	I_{DD_STB}	$V_{EN1,2}=0V$, PV_{DD} =open	—	—	1	μA

■ THERMAL CHARACTERISTICS

PARAMETER	SYMBOL	VALUE		UNIT
Junction-to-ambient thermal resistance	θ_{ja}	EQFN24-LE	126 ⁽³⁾ 45 ⁽⁴⁾	$^{\circ}\text{C/W}$
Junction-to-Top of package characterization parameter	ψ_{jt}	EQFN24-LE	8.0 ⁽³⁾ 2.8 ⁽⁴⁾	$^{\circ}\text{C/W}$

(3): Mounted on glass epoxy board. (101.5×114.5×1.6mm: based on EIA/JEDEC standard, 2Layers FR-4, with Exposed Pad)

(4): Mounted on glass epoxy board. (101.5×114.5×1.6mm: based on EIA/JEDEC standard, 4Layers FR-4, with Exposed Pad)

(For 4Layers: Applying 99.5×99.5mm inner Cu area and thermal via holes to a board based on JEDEC standard JESD51-5)

■ POWER DISSIPATION vs. AMBIENT TEMPERATURE

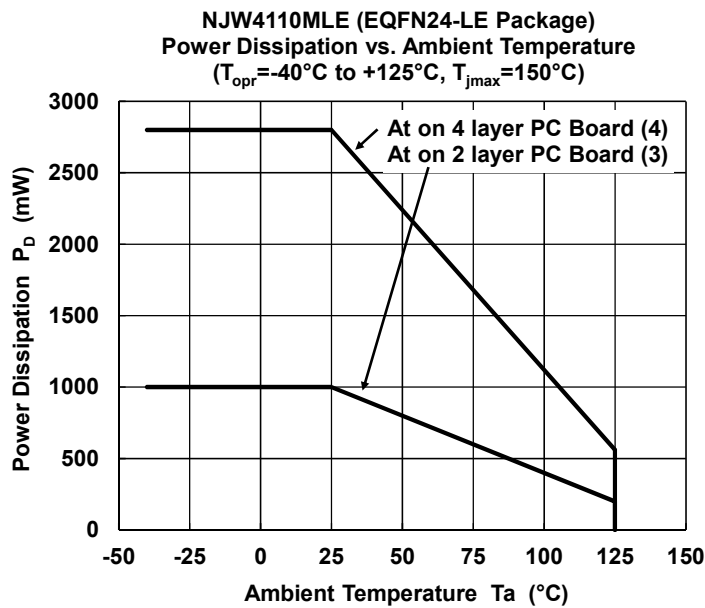

■TYPICAL APPLICATION

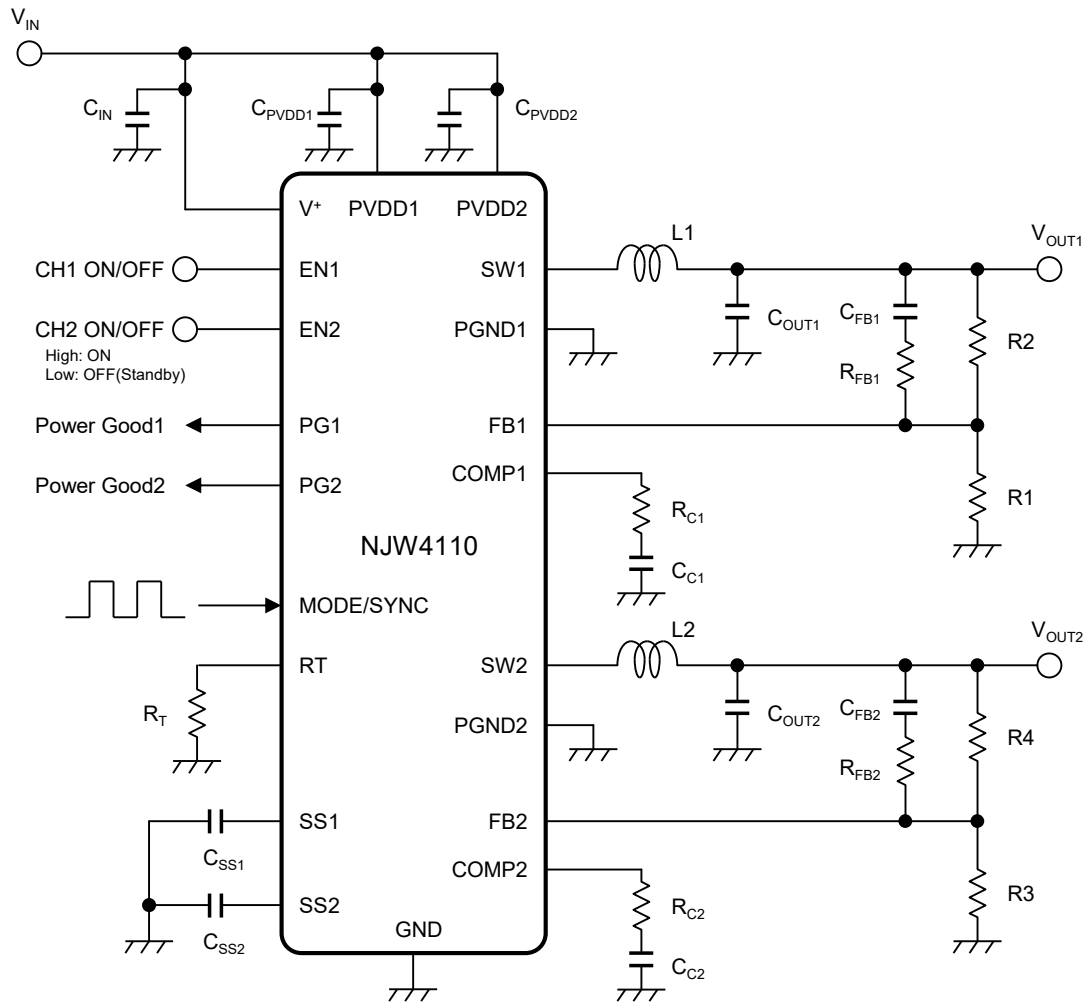

Operating mode select with the MODE/SYNC pin

MODE/SYNC pin Voltage	Operating Mode	Oscillating Frequency
1.2V to 5.5V	Forced PWM operation	Internal frequency
0V to 0.4V	PWM/PFM operation for light loads	Internal frequency
External clock input	Forced PWM operation	External clock frequency

■ TYPICAL CHARACTERISTICS

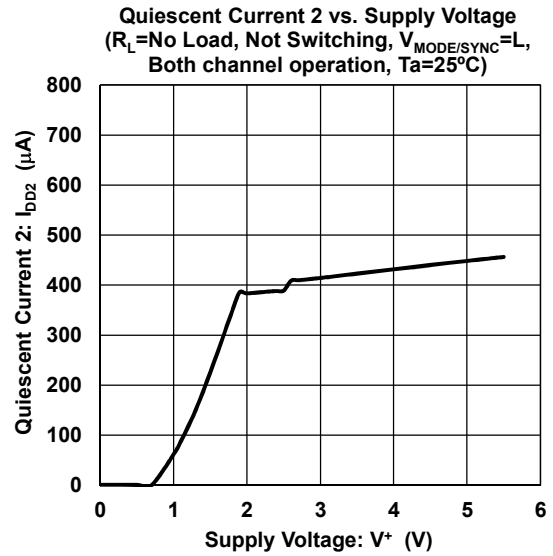
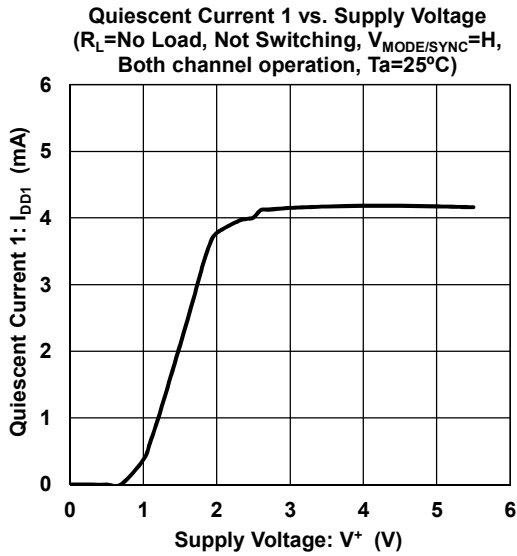
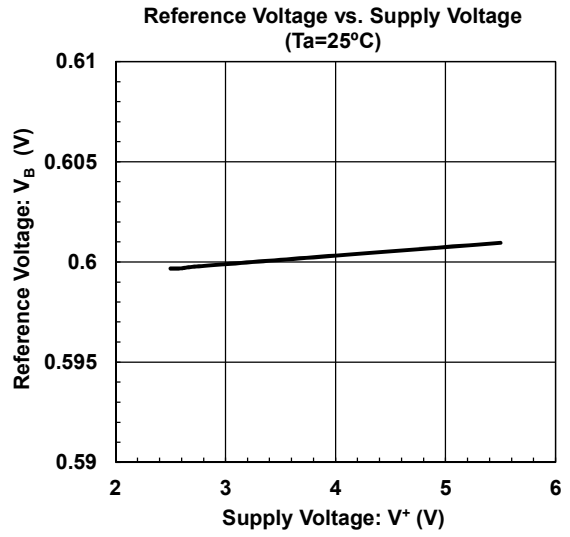
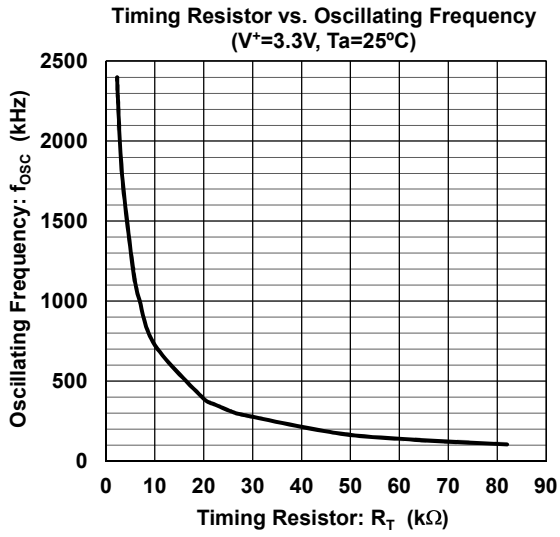

■ TYPICAL CHARACTERISTICS

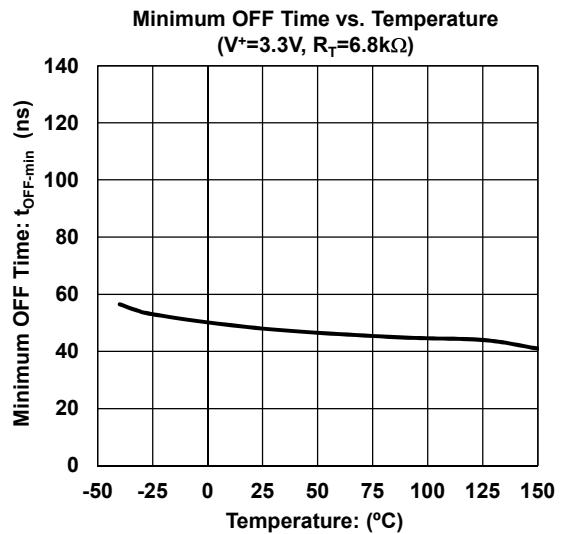
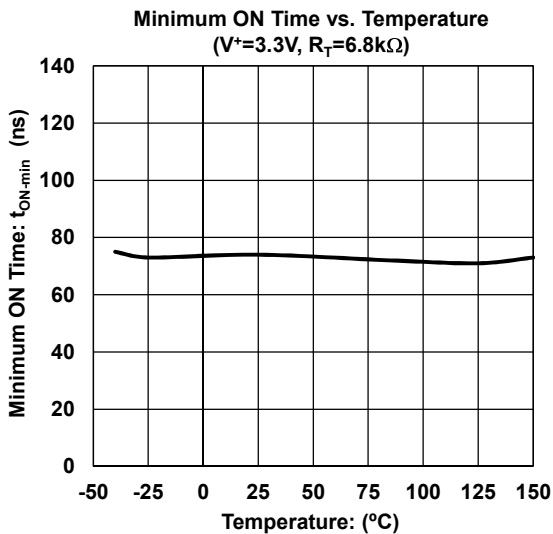
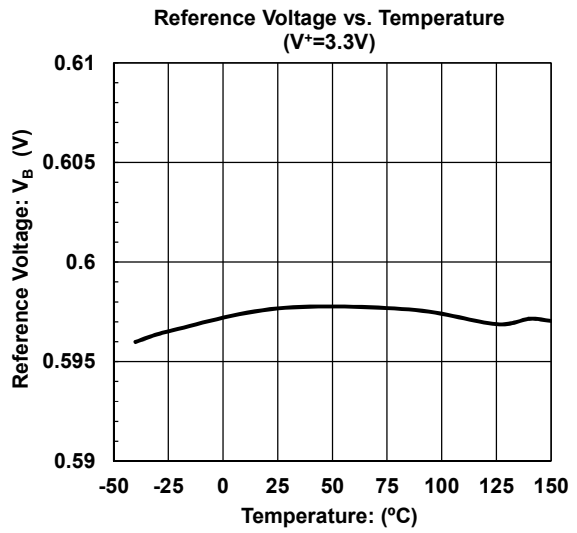
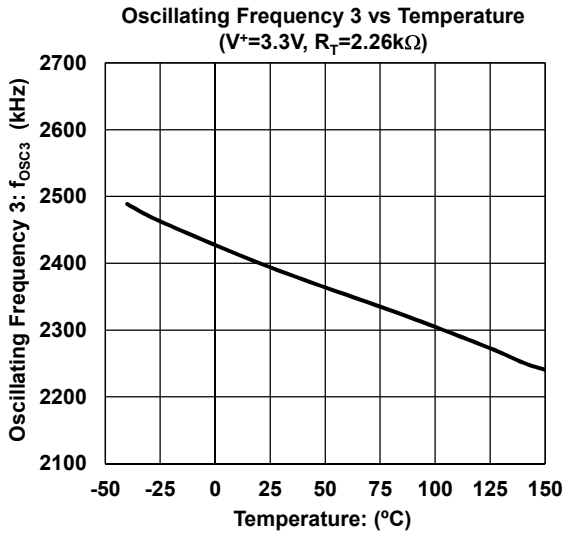
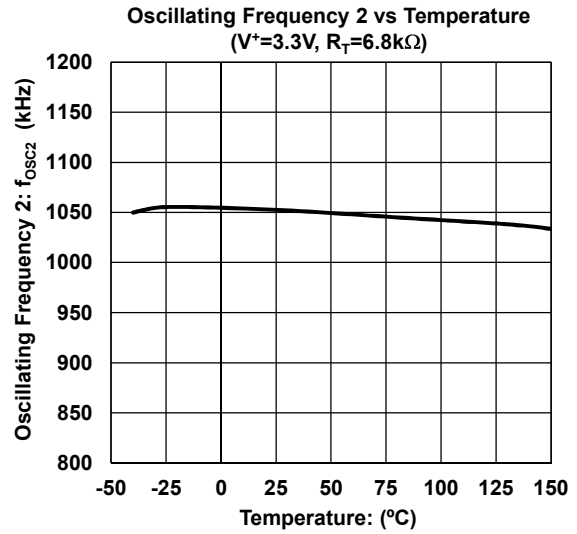
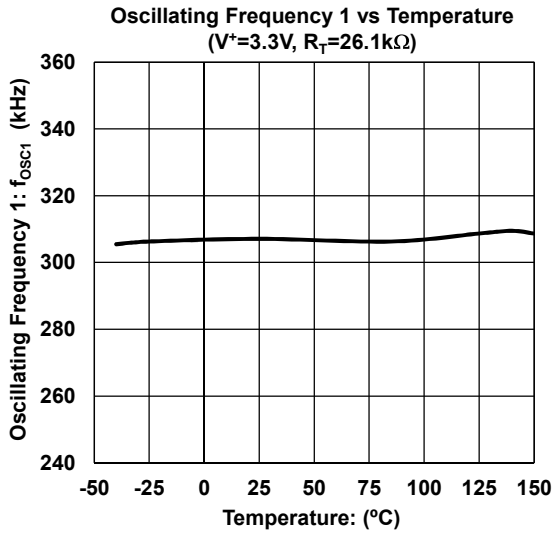

■ TYPICAL CHARACTERISTICS

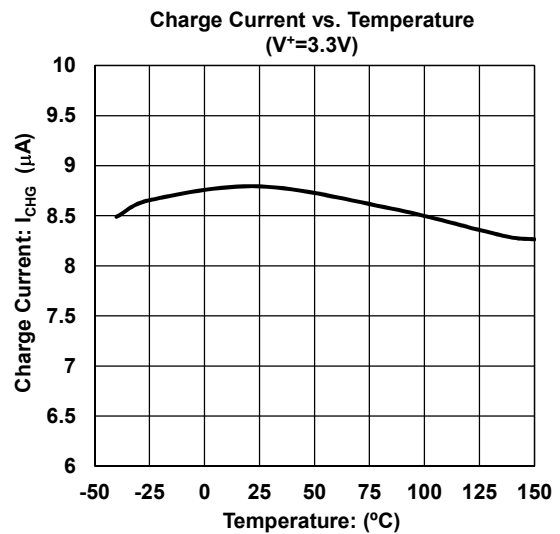
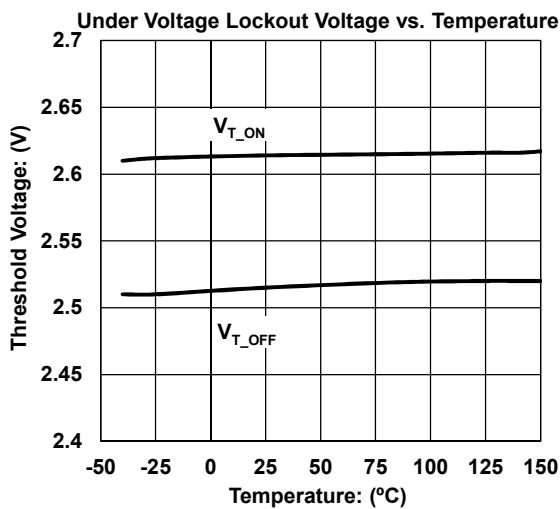
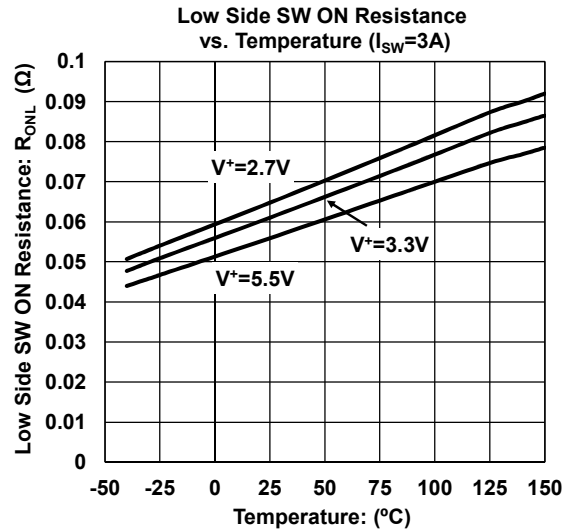
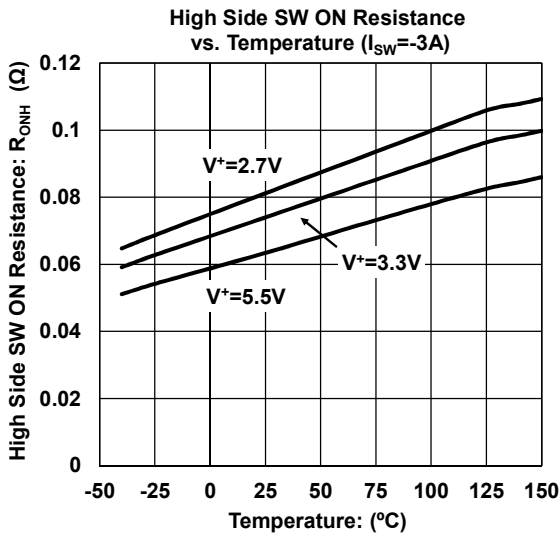
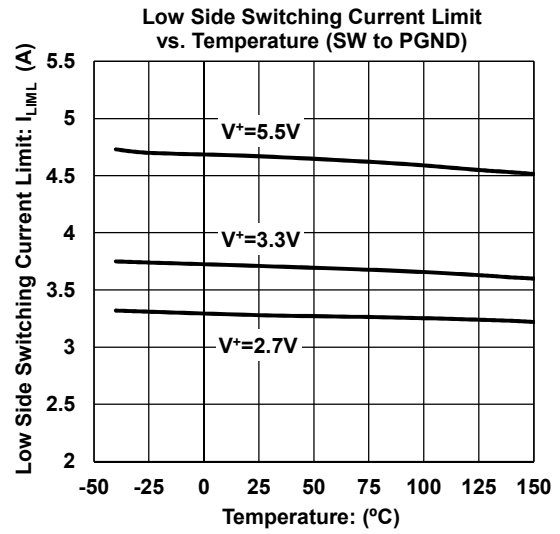
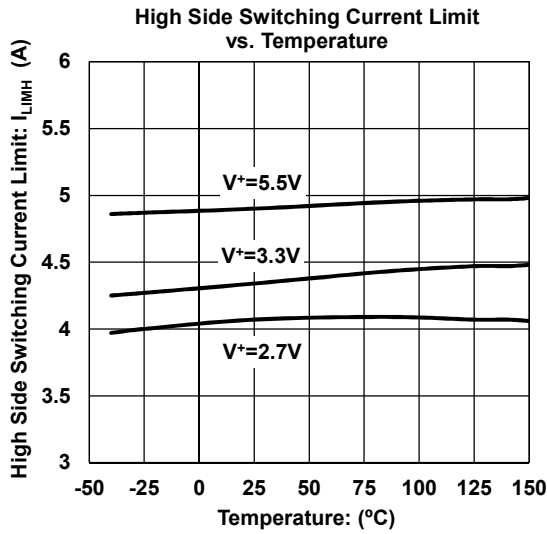

■ TYPICAL CHARACTERISTICS

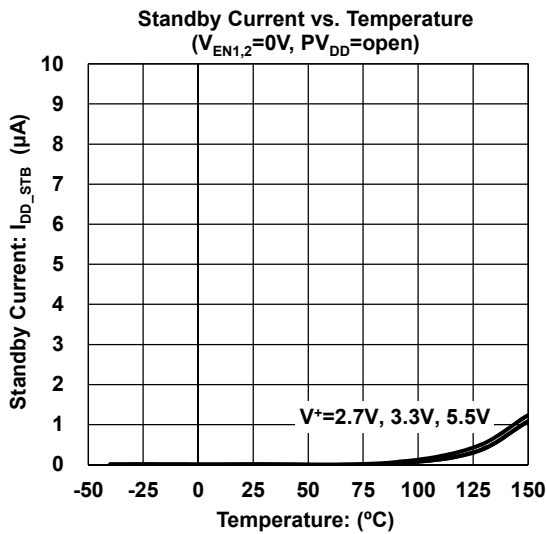
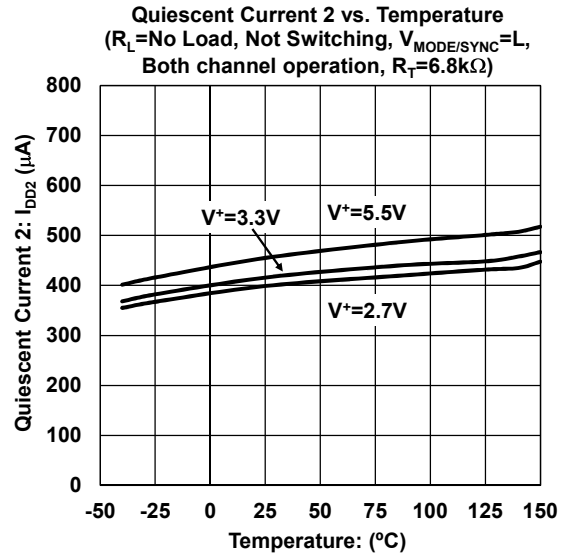
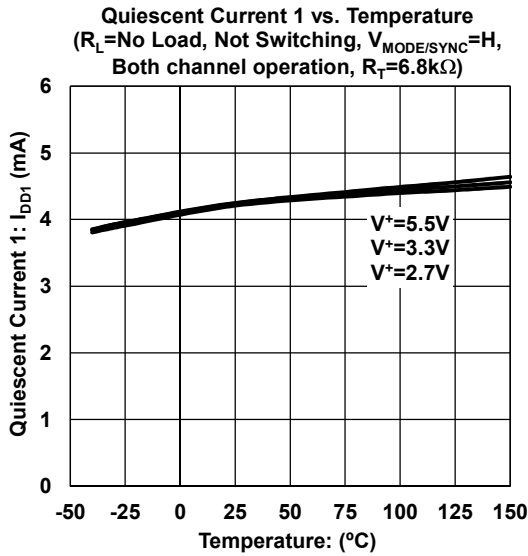
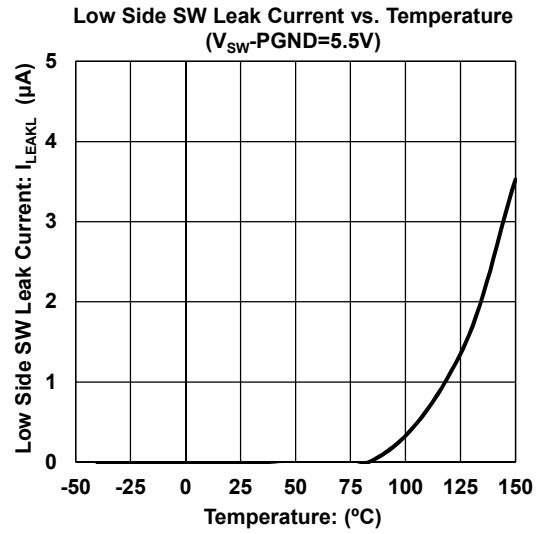
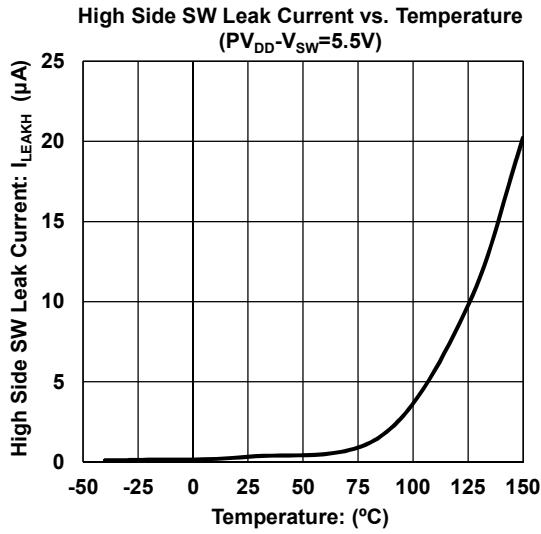

■ PIN DESCRIPTIONS

PIN NAME	PIN NUMBER	FUNCTION
SS1	1	Soft Start timer setting pin of Ch.1. Soft start time is controlled by a capacitor.
RT	2	Oscillating Frequency Setting pin by Timing Resistor. Oscillating Frequency should set between 100kHz and 2.4MHz.
MODE/SYNC	3	Operating mode select pin. The MODE/SYNC pin internally pulls down resistor. Forced PWM operation at the time of High Level. PWM/PFM mode operation at the time of Low Level or OPEN. Moreover, it operates by inputting clock signal at the oscillatory frequency that synchronized with the input signal.
GND	4	GND pin
SS2	5	Soft Start timer setting pin of Ch.2. It has the same function as the SS1 pin.
PG2	6	Power Good pin of Ch.2. An open drain output that goes high impedance when the FB pin voltage is stable around +7% to -5%.
COMP2	7	Output pin of the Error Amplifier of Ch.2. A resistor and capacitors for compensation are connected between the COMP pin and the GND.
FB2	8	Output Voltage Detecting pin of Ch.2. Connects output voltage through the resistor divider tap to this pin in order to voltage of the FB pin become 0.6V.
EN2	9	Standby Control pin of Ch.2. The EN pin internally pulls down resistor. Normal Operation at the time of High Level. Standby Mode at the time of Low Level or OPEN.
V ⁺	10	Power Supply pin for IC control. Insert a bypass capacitor close to the V ⁺ pin – the GND pin connection in order to lower high frequency impedance.
PVDD2	11	Power Supply pin for Power Line of Ch.2.
PVDD2	12	
SW2	13	Switch Output pin of Power MOSFET of Ch.2.
PGND2	14	Power GND pin for Power Line of Ch.2.
PGND2	15	
PGND1	16	Power GND pin for Power Line of Ch.1.
PGND1	17	
SW1	18	Switch Output pin of Power MOSFET of Ch.1.
PVDD1	19	Power Supply pin for Power Line of Ch.1.
PVDD1	20	
EN1	21	Standby Control pin of Ch.1. It has the same function as the EN2 pin.
FB1	22	Output Voltage Detecting pin of Ch.1. It has the same function as the FB2 pin.
COMP1	23	Output pin of the Error Amplifier of Ch.1. It has the same function as the COMP2 pin.
PG1	24	Power Good pin of Ch.1. It has the same function as the PG2 pin.
Exposed PAD	–	Exposed PAD on backside should be connected to ground and soldered to PCB.

EQFN24-LE

Unit: mm

PACKAGE DIMENSIONS

EXAMPLE OF SOLDER PADS DIMENSIONS

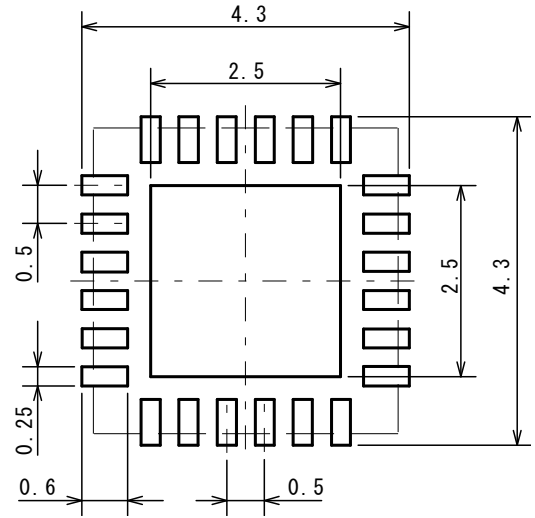
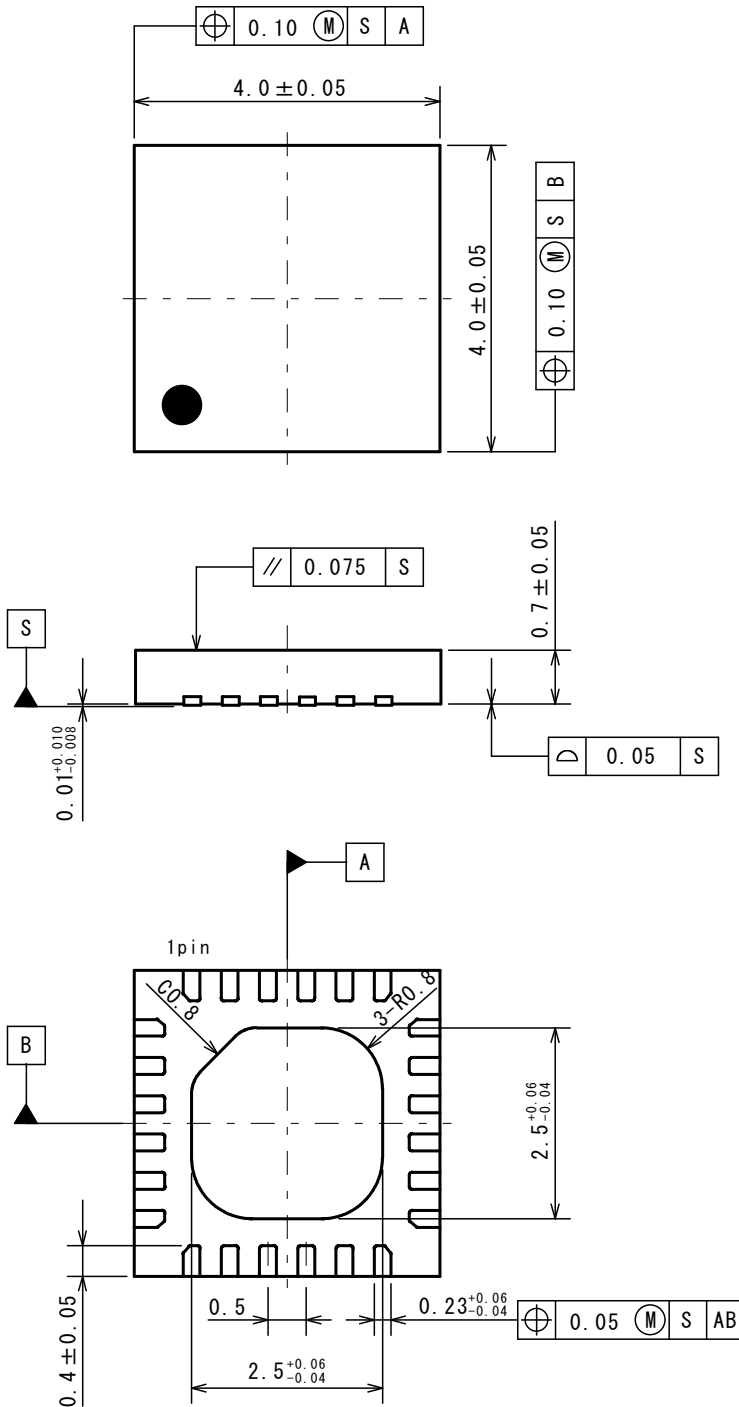

PACKING SPEC

TAPING DIMENSIONS

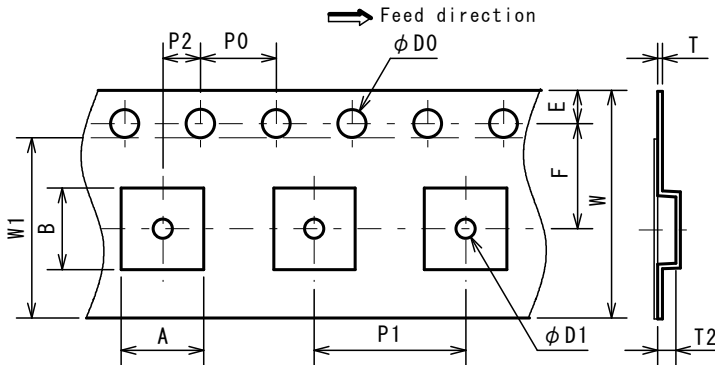

SYMBOL	DIMENSION	REMARKS
A	4.35±0.05	BOTTOM DIMENSION
B	4.35±0.05	BOTTOM DIMENSION
D0	1.5 ^{+0.1} ₀	
D1	1.0±0.1	
E	1.75±0.1	
F	5.5±0.05	
P0	4.0±0.1	
P1	8.0±0.1	
P2	2.0±0.1	
T	0.3±0.05	
T2	1.3±0.05	
W	12.0±0.3	
W1	9.5	THICKNESS 0.1max

REEL DIMENSIONS

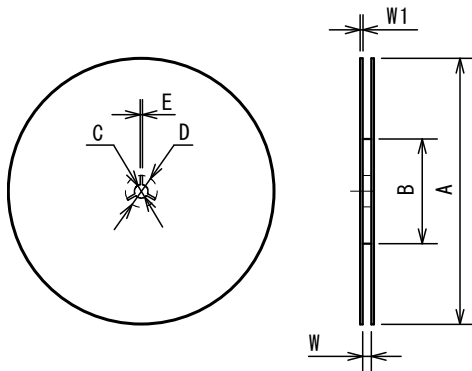

SYMBOL	DIMENSION
A	φ 180 ⁰ _{-1.5}
B	φ 60 ⁺¹ ₀
C	φ 13±0.2
D	φ 21±0.8
E	2±0.5
W	13 ^{+1.0} ₀
W1	1.2

TAPING STATE

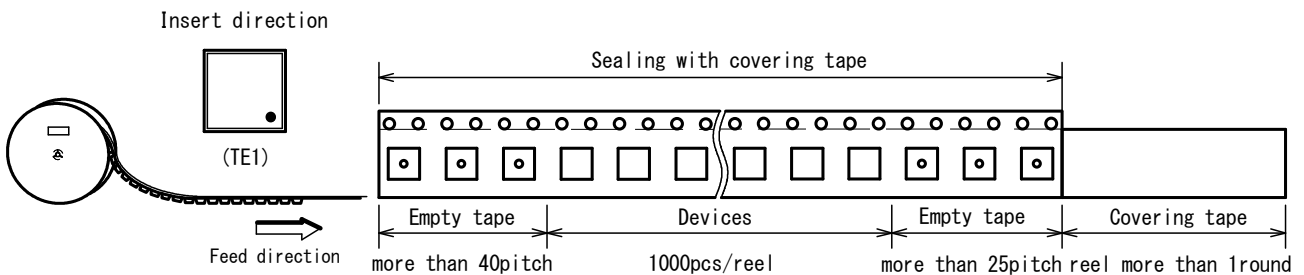

PACKING STATE

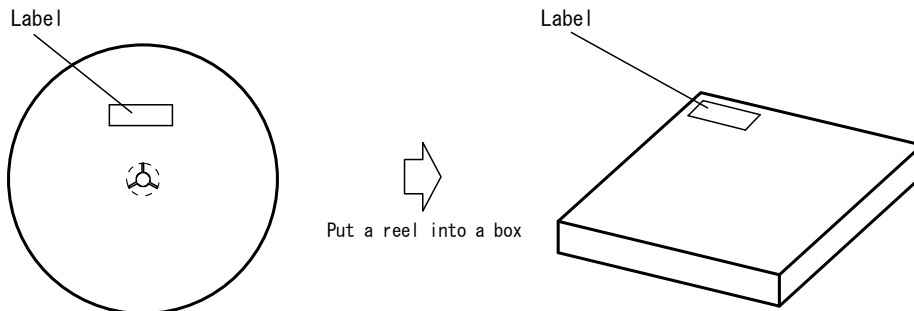

■MOUNTING METHOD

INFRARED REFLOW SOLDERING METHOD

Recommended reflow soldering procedure

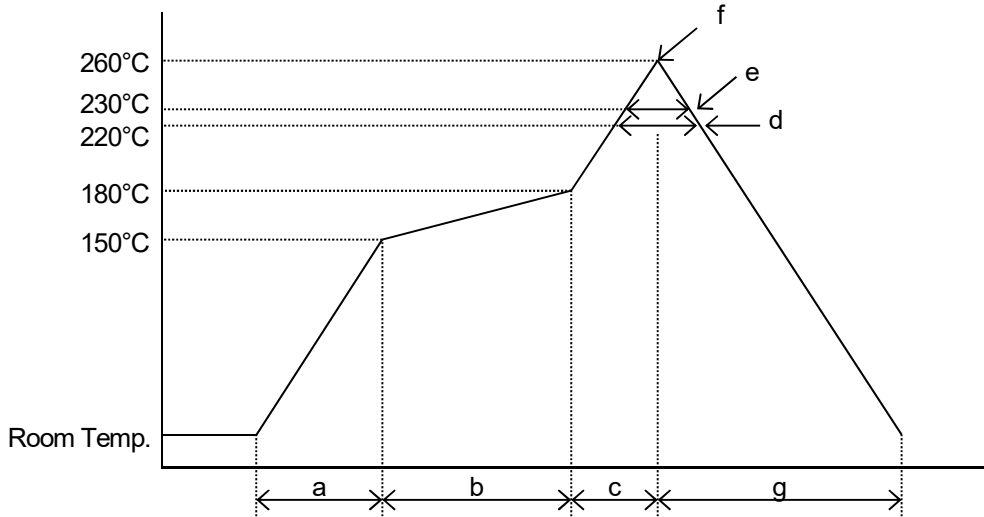

- | | |
|---------------------------------|-----------------------------|
| a: Temperature ramping rate | : 1 to 4°C/s |
| b: Pre-heating temperature time | : 150 to 180°C : 60 to 120s |
| c: Temperature ramp rate | : 1 to 4°C/s |
| d: 220°C or higher time | : Shorter than 60s |
| e: 230°C or higher time | : Shorter than 40s |
| f: Peak temperature | : Lower than 260°C |
| g: Temperature ramping rate | : 1 to 6°C/s |

The temperature indicates at the surface of mold package.

■REVISION HISTORY

DATE	REVISION	CHANGES
21.Aug.2017	Ver.1.0	New Release

[CAUTION]

1. New JRC strives to produce reliable and high quality semiconductors. New JRC's semiconductors are intended for specific applications and require proper maintenance and handling. To enhance the performance and service of New JRC's semiconductors, the devices, machinery or equipment into which they are integrated should undergo preventative maintenance and inspection at regularly scheduled intervals. Failure to properly maintain equipment and machinery incorporating these products can result in catastrophic system failures
2. The specifications on this datasheet are only given for information without any guarantee as regards either mistakes or omissions. The application circuits in this datasheet are described only to show representative usages of the product and not intended for the guarantee or permission of any right including the industrial rights.
All other trademarks mentioned herein are property of their respective companies.
3. To ensure the highest levels of reliability, New JRC products must always be properly handled.
The introduction of external contaminants (e.g. dust, oil or cosmetics) can result in failures of semiconductor products.
4. New JRC offers a variety of semiconductor products intended for particular applications. It is important that you select the proper component for your intended application. You may contact New JRC's Sale's Office if you are uncertain about the products listed in this catalog.
5. Special care is required in designing devices, machinery or equipment which demand high levels of reliability. This is particularly important when designing critical components or systems whose failure can foreseeably result in situations that could adversely affect health or safety. In designing such critical devices, equipment or machinery, careful consideration should be given to amongst other things, their safety design, fail-safe design, back-up and redundancy systems, and diffusion design.
6. The products listed in the catalog may not be appropriate for use in certain equipment where reliability is critical or where the products may be subjected to extreme conditions. You should consult our sales office before using the products in any of the following types of equipment.
 - Aerospace Equipment
 - Equipment Used in the Deep sea
 - Power Generator Control Equipment (Nuclear, Steam, Hydraulic)
 - Life Maintenance Medical Equipment
 - Fire Alarm/Intruder Detector
 - Vehicle Control Equipment (airplane, railroad, ship, etc.)
 - Various Safety devices
7. New JRC's products have been designed and tested to function within controlled environmental conditions. Do not use products under conditions that deviate from methods or applications specified in this catalog. Failure to employ New JRC products in the proper applications can lead to deterioration, destruction or failure of the products. New JRC shall not be responsible for any bodily injury, fires or accident, property damage or any consequential damages resulting from misuse or misapplication of its products. Products are sold without warranty of any kind, either express or implied, including but not limited to any implied warranty of merchantability or fitness for a particular purpose.
8. Warning for handling Gallium and Arsenic(GaAs) Products (Applying to GaAs MMIC, Photo Reflector). This Products uses Gallium(Ga) and Arsenic(As) which are specified as poisonous chemicals by law. For the prevention of a hazard, do not burn, destroy, or process chemically to make them as gas or power. When the product is disposed, please follow the related regulation and do not mix this with general industrial waste or household waste.
9. The product specifications and descriptions listed in this catalog are subject to change at any time, without notice.

