

PROJEKT NR.:		REVISIONS		
PRJ-16-910102		ÄNDERUNGEN	DATE	OWN
P	LTA	DESCRIPTION	DATE	OWN
B		NEW DRAWING	15MAY2018	HH

RECEPTACLE HOUSING ASSY. IN PRE-LOCKED POSITION  
 Buchsengehäuse in Vorrastellung

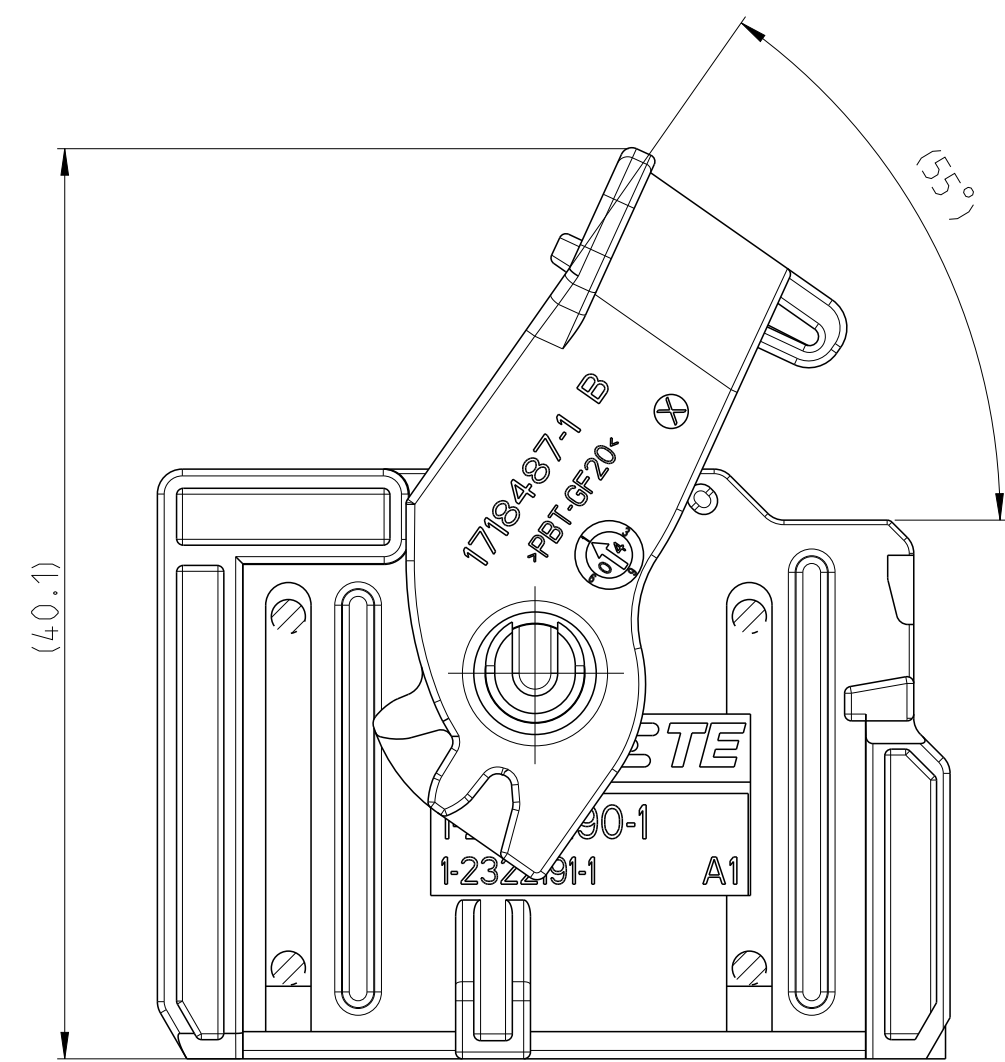

ASSEMBLY WITH SECONDARY LOCKING DEVICE  
 Assemblage mit zweiter Kontaktsicherung

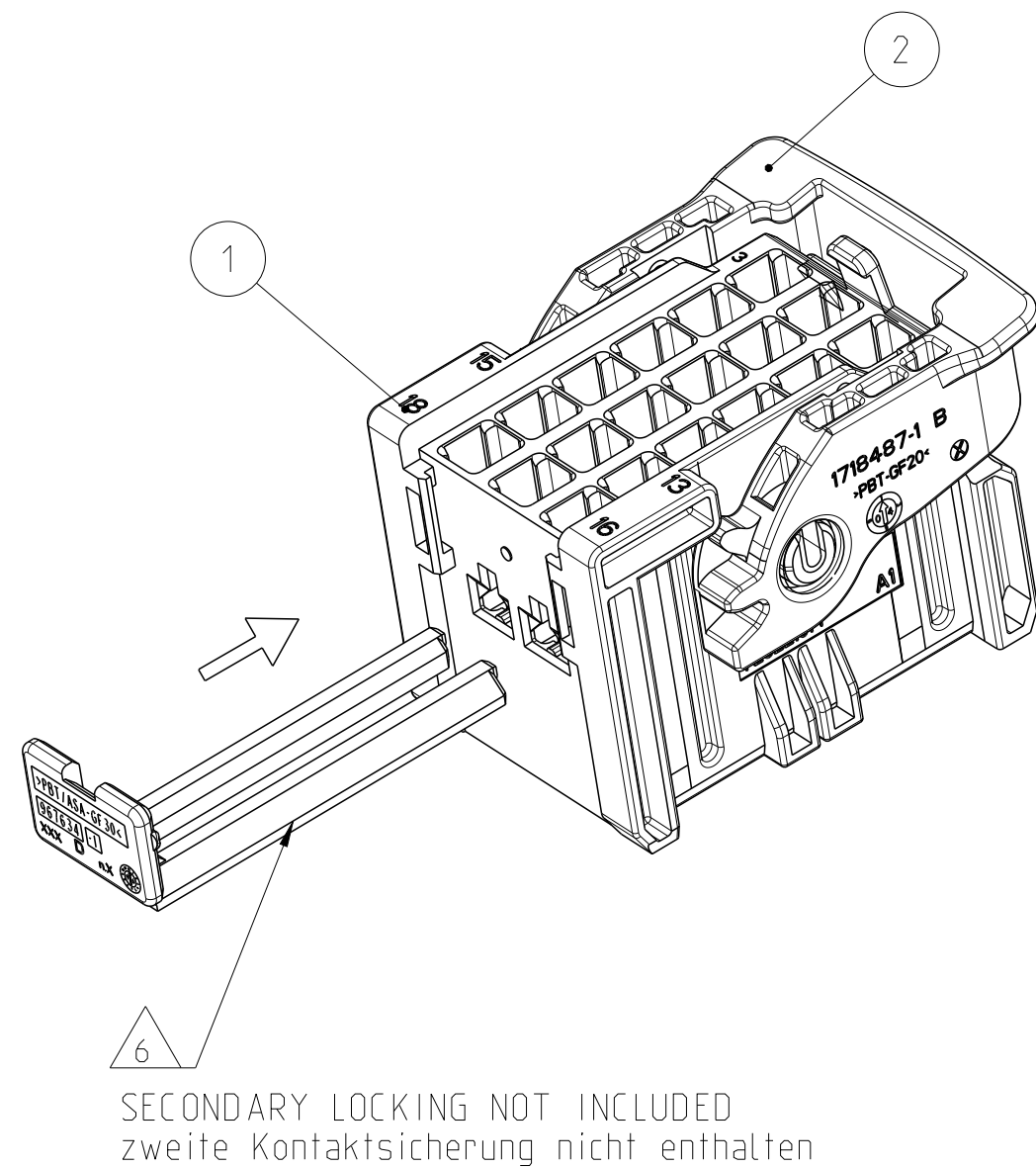

CODING A AS SHOWN  
 Kodierung A wie gezeigt

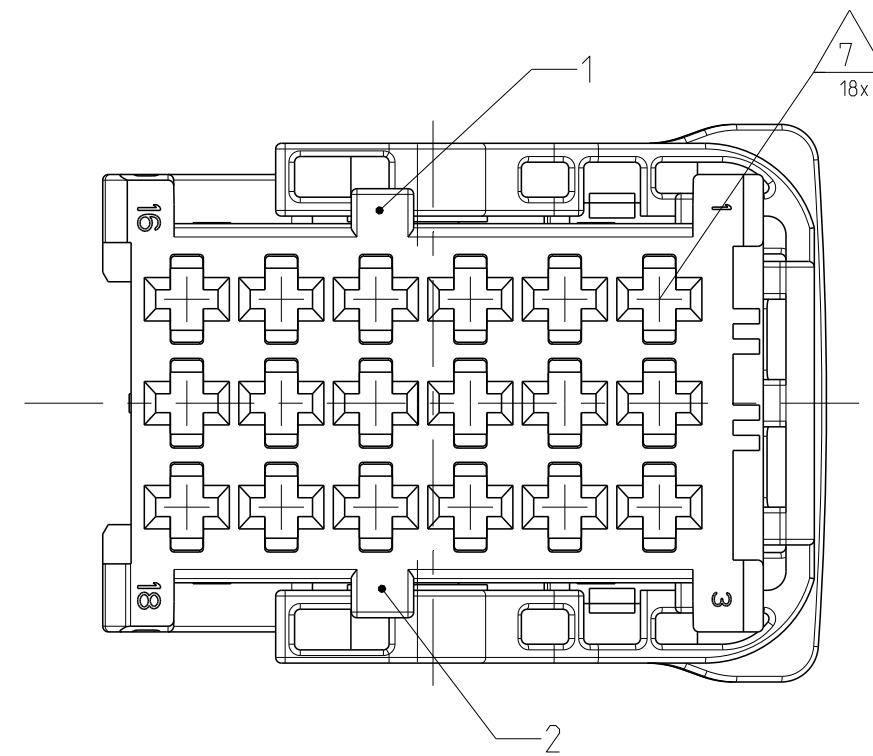

NOTES  
 Bemerkungen

- 1 TE LOGO AND TE ORDER NUMBER  
TE Logo und TE Bestell-Nummer
- 2 PRODUCTION DATE  
Produktionsdatum
- 3 MATERIAL IDENTIFICATION ACC. TO VDA 260  
Werkstoffkennzeichnung nach VDA 260
- 4 BULK PACKAGING IN CORRUGATED BOX  
Schuetztgut im Versandkarton
- 5 SUITABLE COUNTERPART 2.8 MM TAB HOUSING, 18POS.  
SEE PRODUCT GROUP DRAWING  
TE-NO.: 2322192  
Passende Gegenstecker 2.8 mm Flachsteckergeh.. 18pol.  
siehe Produktgruppenzeichnung  
TE-Nr.: 2322192
- 6 SUITABLE SECONDARY LOCKING DEVICE  
TE-NO.: 967634  
Passende zweite Kontaktsicherung  
TE-Nr.: 967634

- 7 CAVITIES MATED WITH AMP MCP 2.8  
SEE PRODUCT GROUP DRAWING  
TE-NO.: 1355036  
MAX. WIRE SIZE: 2.5mm<sup>2</sup> FLR  
Kontaktkammern passend fuer AMP MCP 2.8  
siehe Produkt-Gruppenzeichnung  
TE-Nr.: 1355036  
max. Drahtgroessenbereich 2.5mm<sup>2</sup> FLR
- 8 THE USE OF LAQUER MAY RESULT IN HIGHER OPERATION  
FORCES THAN SPECIFIED IN THE PRODUCT SPECIFICATION.  
THIS CAN LEAD TO A BREAK OF OPERATION AIDS  
(LEVER, SLIDES...) IN THE WORST CASE.  
A QUALIFICATION OF THE USED LAQUER FOR THE MATERIALS  
OF THE CONNECTORS MUST BE DONE BY THE APPLYING USER.  
Eine Lackierung der Steckverbindung kann hoehere Betaetigungskraefte zur  
Folge haben, als in der Produktspezifikation angegeben.  
Dies kann im unguenstigsten Fall auch zum Bruch von Betaetigungshilfen  
(Hebel, Schieber...) fuehren.  
Die Eignung des verwendeten Lackes fuer die Werkstoffe der  
Steckverbindung ist vom Anwender zu ueberpruefen.

CODING B  
 Kodierung  
 2-2322190-1

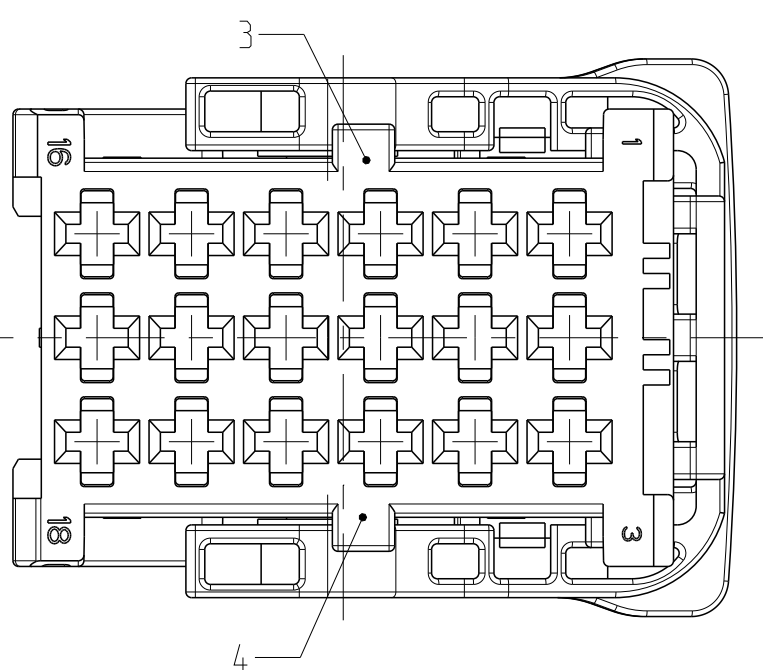

DELIVERY CONDITION:  
 Lieferzustand:  
 LEVER IN LOCKED POSITION  
 Hebel in Verriegelungsstellung

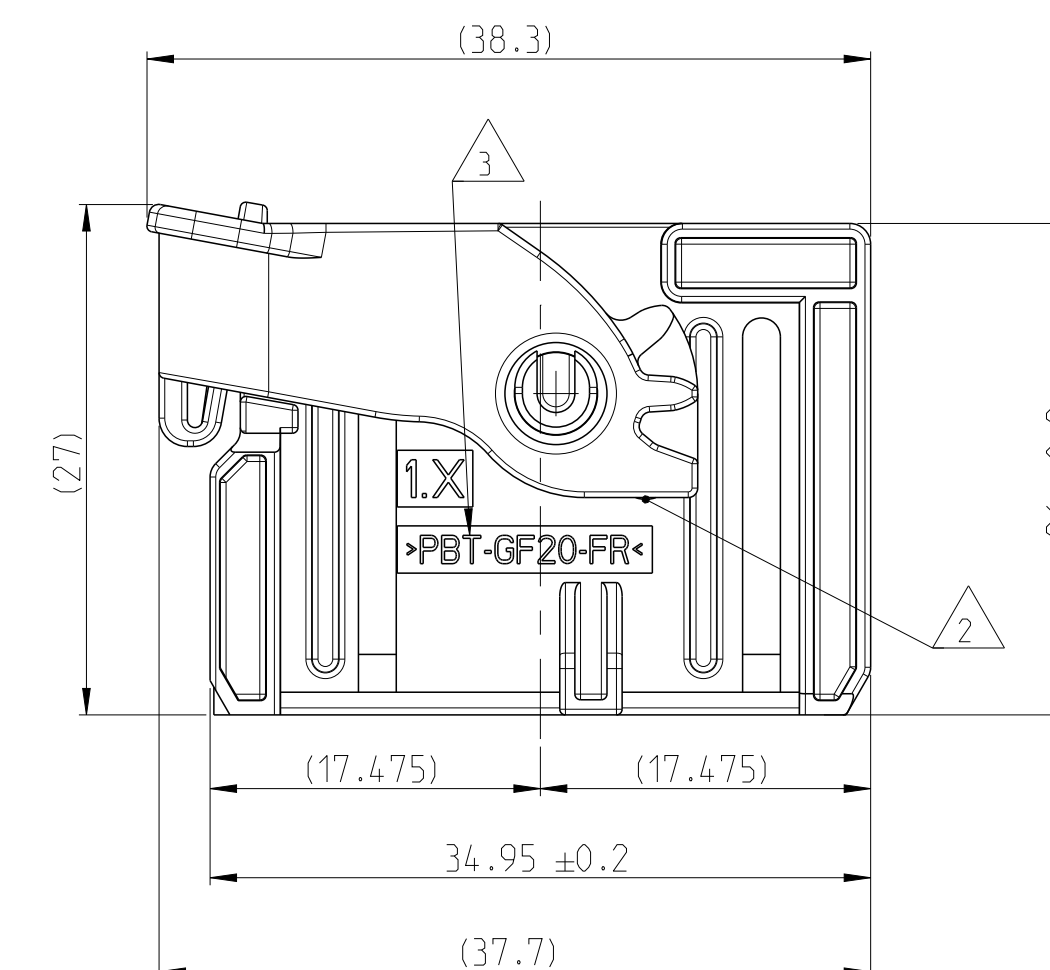
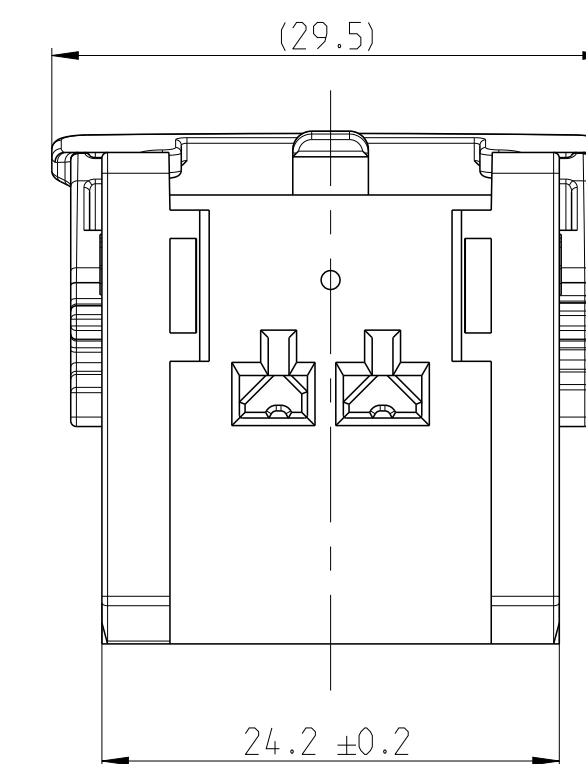
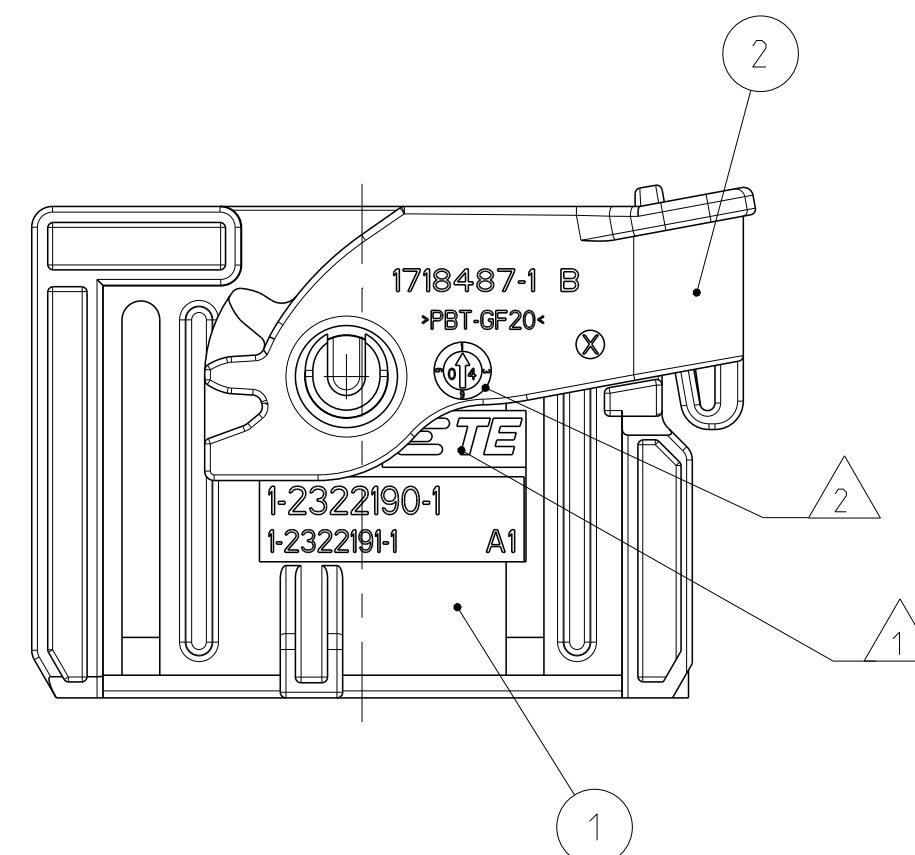
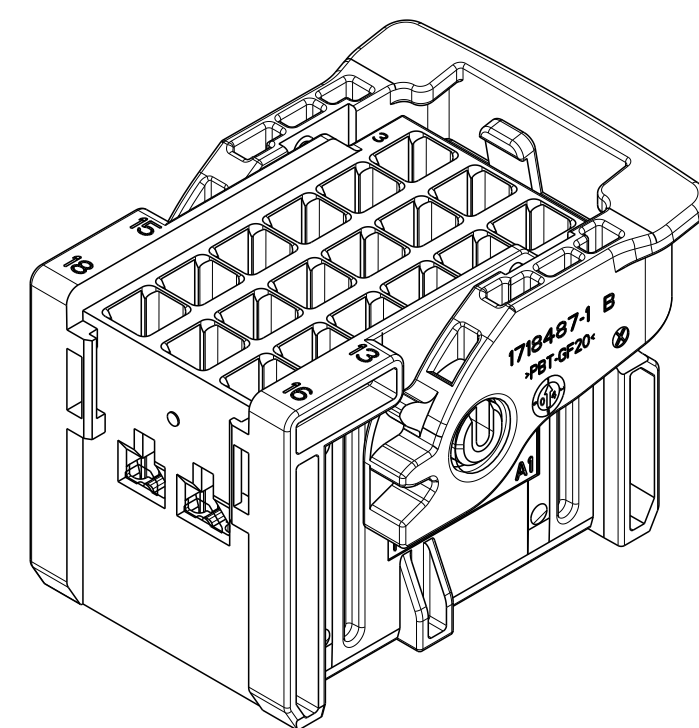

CODING C  
 Kodierung  
 3-2322190-1

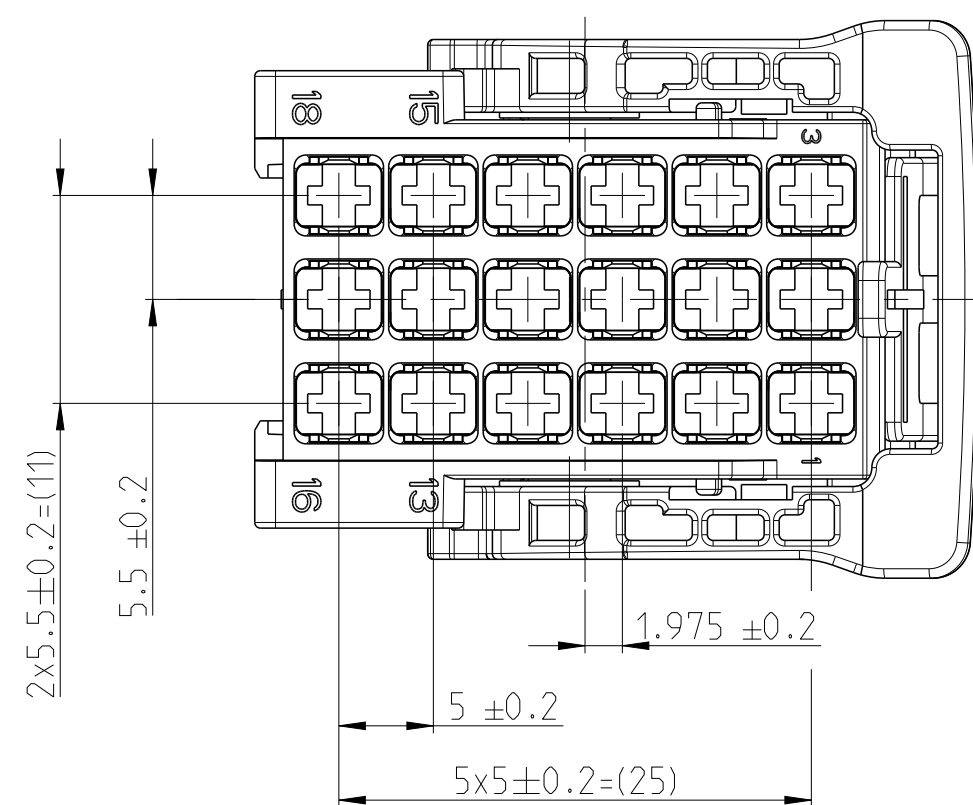
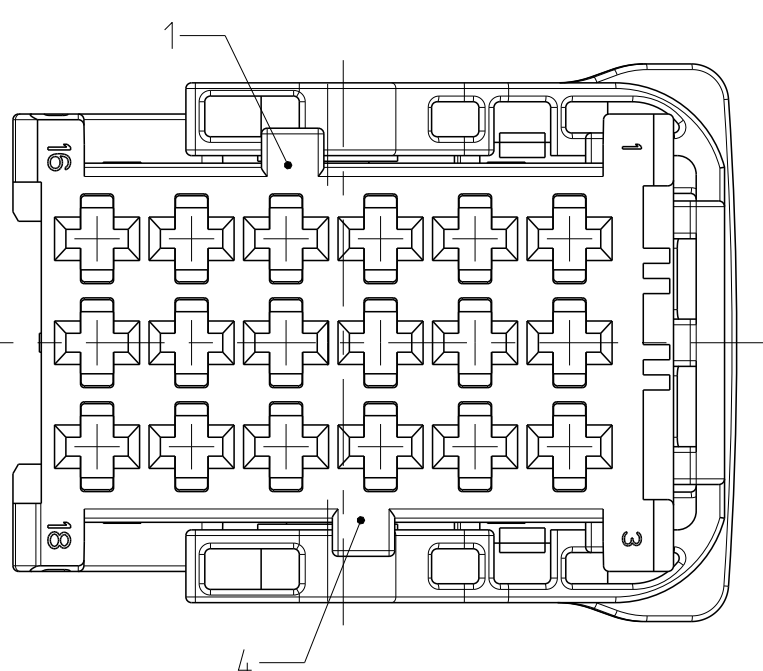

CODING D  
 Kodierung  
 4-2322190-1

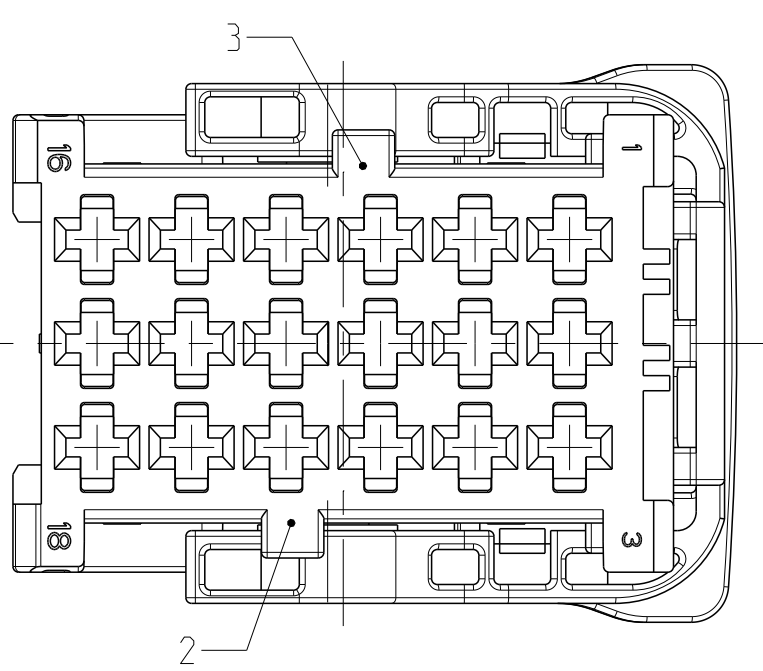

DIMENSION AND TOLERANCES ACCORDING TO:  
 Bemerkungen und Toleranzen gemäß:

CODE	TE ORDER-NO.	REV.	QTY	MATERIAL	COLOR	DESCRIPTION	ITEM
Kodierung	TE Bestell-Nr.		Anzahl		Farbe	Beschreibung	
D	4-2322190-1	B	1	PBT-GF20	YELLOW gelb	LEVER Hebel	2
		B	1	PBT-GF20-FR	CLARET VIOLET Bordauxviolett	RECEPTACLE HOUSING CODE D Buchsengehäuse Kodierung D	1
C	3-2322190-1	B	1	PBT-GF20	YELLOW gelb	LEVER Hebel	2
		B	1	PBT-GF20-FR	BLUE blau	RECEPTACLE HOUSING CODE C Buchsengehäuse Kodierung C	1
B	2-2322190-1	B	1	PBT-GF20	NATURAL natur	LEVER Hebel	2
		B	1	PBT-GF20-FR	YELLOW gelb	RECEPTACLE HOUSING CODE B Buchsengehäuse Kodierung B	1
A	1-2322190-1	B	1	PBT-GF20	YELLOW gelb	LEVER Hebel	2
		B	1	PBT-GF20-FR	BLACK schwarz	RECEPTACLE HOUSING CODE A Buchsengehäuse Kodierung A	1

DIN 16742	DIN EN ISO 8015 (A1) - DIN EN ISO 291	DIN EN ISO 14405	THIS DRAWING IS A CONTROLLED DOCUMENT. DIMENSIONING AND TOLERANCING PER GPS (ISO STANDARDS)	OWN: PRAJWAL P CHK: H. HINDRICHS APVD: F. ELTROP 15MAY2018	20SEP2017 15MAY2018 15MAY2018	NAME: 18POS. RECEPTACLE HOUSING, ASSY 18pol. Buchsengehäuse, Assy	SIZE: A1	CAGE CODE: 00779	DRAWING NO: 2322190	RESTRICTED TO: NUR FÜR
DIMENSIONS: MASSENHEITEN: mm			TOLERANCES UNLESS OTHERWISE SPECIFIED: ALLE TOLERANZEN	APPLICATION SPEC: VERARBEITUNGSSPEZ.		SCALE: 1:1	SHEET: 1	OF: 1	REV: B	RESTRICTED CUSTOMER