

NOTE:
 1.MATERIAL:
 HOUSING: POLYESTER GLASS FILLED,UL94-V0,
 COLOR:BLACK
 TERMINAL: BRASS
 METAL SHELL: SPCC
 BOARD LOCK: BRASS
 SCREW: BRASS
 2.PLATING:
 TERMINAL:
 CONTACT AREA: SEE PART NUMBER LEGEND
 SOLDER TAIL: TIN(Sn),THICKNESS=100 MICREINCH MIN/2.54 MICROMETER MIN.
 UNDER PLATE: NICKEL(Ni),THICKNESS=50 MICROINCH MIN/1.27 MICROMETER MIN.
 METAL SHELL:TIN(Sn),THICKNESS=100 MICREINCH MIN/2.54 MICROMETER MIN.
 UNDER PLATE: COPPER(Cu),THICKNESS=50 MICROINCH MIN/1.27 MICROMETER MIN.
 BOARD LOCK: TIN (Sn),THICKNESS=100 MICREINCH MIN/2.54 MICROMETER MIN.
 SCREW: NICKEL(Ni),THICKNESS=50 MICROINCH MIN/1.27 MICROMETER MIN.
 3.RECOMMENDED PCB THICKNESS: 1.60+/-0.05mm
 4.PRODUCT SPECIFICATION: REFER TO PS-48201-001
 5.TEST SUMMARY: REFER TO TS-48202-001
 6.PACKAGING SPECIFICATION: REFER TO PK-48201-001
 7.LEAD FREE AND ROHS COMPLIANCE PRODUCT

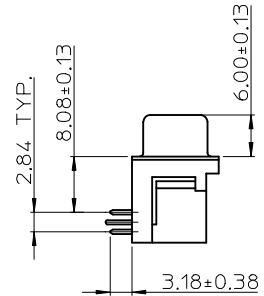
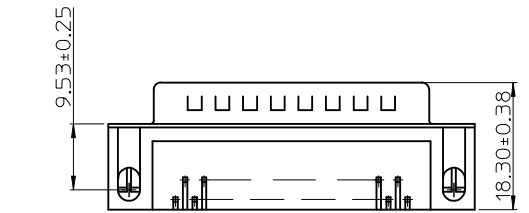
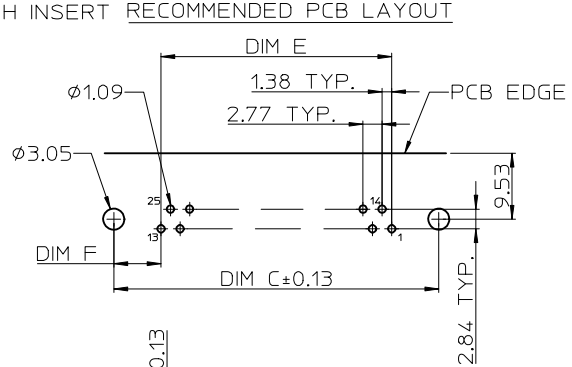
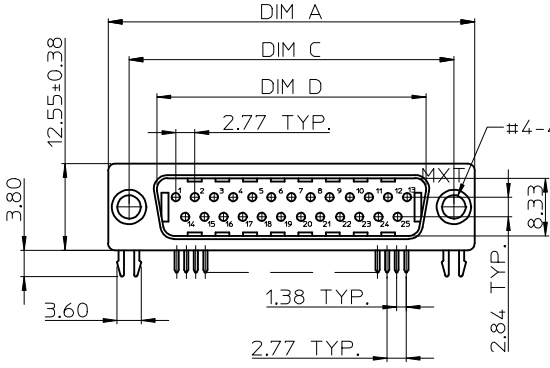

PART NUMBER LEGEND

CKT SIZE	PLATING	SCREW OPTION
48202-6	*	*
0:9		1:2 PCS #4-40 ROUND INNER THREAD SCREW RIVETTED
1:15		2:FLUSH INSERT ONLY
3:25		3:2 PCS #4-40 HEX INNER THREAD SCREW ASSEMBLED
4:37		4:2 PCS M2.6 INNER THREAD SCREW ASSEMBLED
		5:2 PCS M3 INNER THREAD SCREW ASSEMBLED
		6:2 PCS #4-40 HEX INNER THREAD SCREW ATTACHED
		7:2 PCS M2.6 INNER THREAD SCREW ATTACHED
		8:2 PCS M3 INNER THREAD SCREW ATTACHED

4:30 MICRO INCH MINIMUM GOLD IN CONTACT AREA
 5:15 MICRO INCH MINIMUM GOLD IN CONTACT AREA
 6:GOLD FLASH IN CONTACT AREA

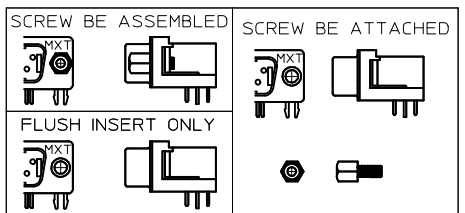

CKT SIZE	DIM A	DIM C	DIM D	DIM E	DIM F
9	30.81	24.99	16.92	11.07	6.96
15	39.14	33.32	25.25	19.38	6.97
25	53.04	47.04	38.96	33.22	6.91
37	69.32	63.50	55.45	49.83	6.84

PER EWR 2007-0013 EC NO: SH2007-0097 DRWN:ALL IN 2006/09/18 CHKD: 2006/09/18 APPR:WMSCHANG 2006/09/18	QUALITY SYMBOLS ▽=0 ▽=0	GENERAL TOLERANCES (UNLESS SPECIFIED)		DIMENSION STYLE MM/IN		SCALE	DESIGN UNITS	THIRD ANGLE PROJECTION		
								TITLE STANDARD D-SUB MALE TYPE FORK BOARD LOCK		
						DRAWN BY DATE LINDA 2005/04/26		MOLEX INCORPORATED		
						CHECKED BY DATE ALL IN 2005/04/26		APPROVED BY DATE WWSCHANG 2005/04/26		DOCUMENT NO. SD-48202-001
				MATERIAL NO. SEE NOTES		SHEET NO. 1 OF 1		DRAFT WHERE APPLICABLE MUST REMAIN WITHIN DIMENSIONS		