

AIMS POWER™

www.aimscorp.net

Global LF Series Pure Sine Wave Inverter Charger User's Manual

PICOGLF6W12V120V

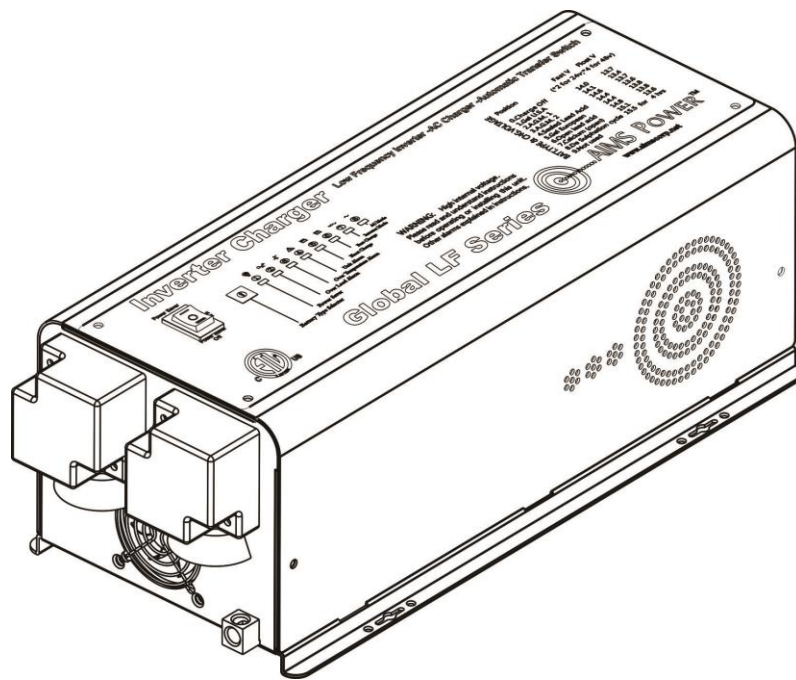

ETL Listed to UL 458 and CSA 22.2 No. 107

Table of Contents

1. Important Safety Information	- 2 -
1.1 General Safety Precautions	- 2 -
1.2 Precautions When Working with Batteries	- 2 -
2. Introduction	- 3 -
2.1 General Information	- 3 -
2.2 Application	- 3 -
2.3 Mechanical Drawing	- 4 -
2.4 Features	- 5 -
2.5 Electrical Performance	- 7 -
2.5.1 Inverter	- 7 -
2.5.2 AC Charger	- 7 -
2.5.3 Transfer	- 10 -
2.5.4 Power Saver	- 10 -
2.5.5 Protections	- 11 -
2.5.6 Remote Control	- 12 -
2.5.7 LED Indicator	- 13 -
2.5.8 Audible Alarm	- 14 -
2.5.9 FAN Operation	- 14 -
2.5.10 DIP Switches	- 14 -
2.5.11 Battery Temperature Sensing	- 16 -
2.5.12 Auto Generator Start	- 17 -
2.5.13 Other Features	- 18 -
3. Installation	- 19 -
3.1 Location	- 19 -
3.2 DC Wiring	- 19 -
3.3 AC Wiring	- 20 -
3.4 Grounding	- 20 -
3.5 Install Flange	- 21 -
4. Troubleshooting Guide	- 22 -
5 Limited Warranty	- 24 -
Appendix 1	- 25 -

1. Important Safety Information



WARNING! Before using the Inverter, read and save the safety instructions. All wiring must follow the National Electric Code, The Canadian Electrical Code Part 1, Provincial or other codes in effect at the time of installation, regardless of suggestions in this manual. All wires should be copper conductors.

1.1 General Safety Precautions

1-1-1. Do not expose the Inverter to rain, snow, spray, bilge or dust. To reduce risk of hazard, do not cover or obstruct the ventilation openings. Do not install the Inverter in a zero-clearance compartment, as overheating may result. Allow at least 12" of clearance around the inverter for air flow. Make sure that the air can circulate freely around the unit. A minimum air flow of 145CFM is required.

1-1-2. To avoid risk of fire and electronic shock, make sure that existing wiring is in good electrical condition and that the wire is not undersized. Do not operate the Inverter with damaged or substandard wiring.

1-1-3. This equipment contains components which may produce arcs and/or sparks. To prevent fire and/or explosion do not install in compartments containing batteries or flammable materials or in a location which require ignition protected equipment. This includes any space containing gasoline-powered machinery, fuel tanks, or joints, fittings, or other connection between components of the fuel system. See Warranty for instructions on obtaining service.

1-1-4. Do not disassemble the Inverter/Charger. It contains no user-serviceable parts. Attempting to service the Inverter/Charger yourself may result in electrical shock or fire. Internal capacitors remain charged after all power is disconnected.

1-1-5. To reduce the risk of electrical shock, disconnect both AC and DC power from the Inverter/Charger before attempting any maintenance or cleaning. Turning off controls will not reduce this risk.

1-1-6. The disconnecting means must be provided as part of the installation. Disconnect shall be rated to handle the input power requirement on AC or DC side. Please install disconnect on the input power side for AC and DC.

CAUTION: Equipment damage

The output side of the inverters' AC wiring should at no time be connected to public power or a generator. This condition is far worse than a short circuit. If the unit survives this condition, it will shut down until corrections are made.

Installation should ensure that the inverters' AC output is, at no time, connected to its AC input.

Warning: Limitations On Use

SPECIFICALLY NOTE THAT THE GLOBAL LF INVERTER/CHARGER SHOULD NOT BE USED IN CONNECTION WITH LIFE SUPPORT SYSTEMS OR OTHER MEDICAL EQUIPMENT OR DEVICES.

1.2 Precautions When Working with Batteries

1-2-1. If battery acid contacts skin or clothing, wash immediately with soap and water. If acid enters eye, immediately rinse eye with running cold water and get medical attention immediately.

1-2-2. Never smoke or allow a spark or flame in the vicinity of a battery or engine.

1-2-3. Do not drop a metal tool on the battery. The resulting spark or short-circuit on the battery may cause an explosion.

1-2-4. Remove personal metal items such as rings, bracelets, necklaces, and watches when working with a lead-acid battery. A lead-acid battery produces a short-circuit current high enough to weld a ring or the like to metal, causing a severe burn.

1-2-5. To reduce the risk of injury, charge only deep-cycle lead acid, lead antimony, lead calcium gel cell, absorbed mat, LIFEPO4 lithium or NiCad/NiFe type rechargeable batteries. Other types of batteries may burst, causing personal injury and damage.

2. Introduction

2.1 General Information

The Global LF Series Pure Sine Wave Inverter Charger product line is a combination of an inverter, battery charger and AC auto-transfer switch into one complete system with a peak conversion efficiency of 80% for 600W models.

It is packed with unique features and it is one of the most advanced inverter/chargers in the market today. It features power factor corrected, sophisticated multi-stage charging and pure sine wave output with unprecedentedly high surge capability to meet demanding power needs of inductive loads without endangering the equipment.

For the regular model, when utility AC power cuts off (or falls out of acceptable range), the transfer relay is de-energized and the load is automatically transferred to the Inverter output. Once the qualified AC utility is restored, the relay is energized and the load is automatically reconnected to AC utility.

The Global LF Series Inverter is equipped with a powerful charger.

The overload capacity is 300% of continuous output for up to 20 seconds to reliably support tools and equipment longer

The AC/Battery priority and auto generator start functionality make it suitable to work in either backup power or renewable energy applications. When customized to Battery priority mode via a DIP switch, the inverter will extract maximum power from external power sources and renewable energy systems, with only minimal battery cycles being required. With the availability of auto generator start, an electrical generator can be integrated into the system and started when the battery voltage goes low.

Thus, the Global LF Series Pure Sine Wave Inverter is suitable for Renewable energy systems, off-grid, utility, RV, marine and emergency appliances.

To get the most out of the power inverter, it must be installed, maintained and used properly. Please read the instructions in this manual before installing and operating.

2.2 Application

Power tools—circular saws, drills, grinders, sanders, buffers, weed and hedge trimmers, air compressors. Office equipment – computers, printers, monitors, facsimile machines, scanners. Household items – vacuum cleaners, fans, fluorescent and incandescent lights, shavers, sewing machines. Kitchen appliances – coffee makers, blenders, ice makers, toasters. Industrial equipment – metal halide lamp, high – pressure sodium lamp. Home entertainment electronics – television, DVRs, video games, stereos, musical instruments, and satellite equipment.

2.3 Mechanical Drawing

PICOGLF6W12V120V DC Side

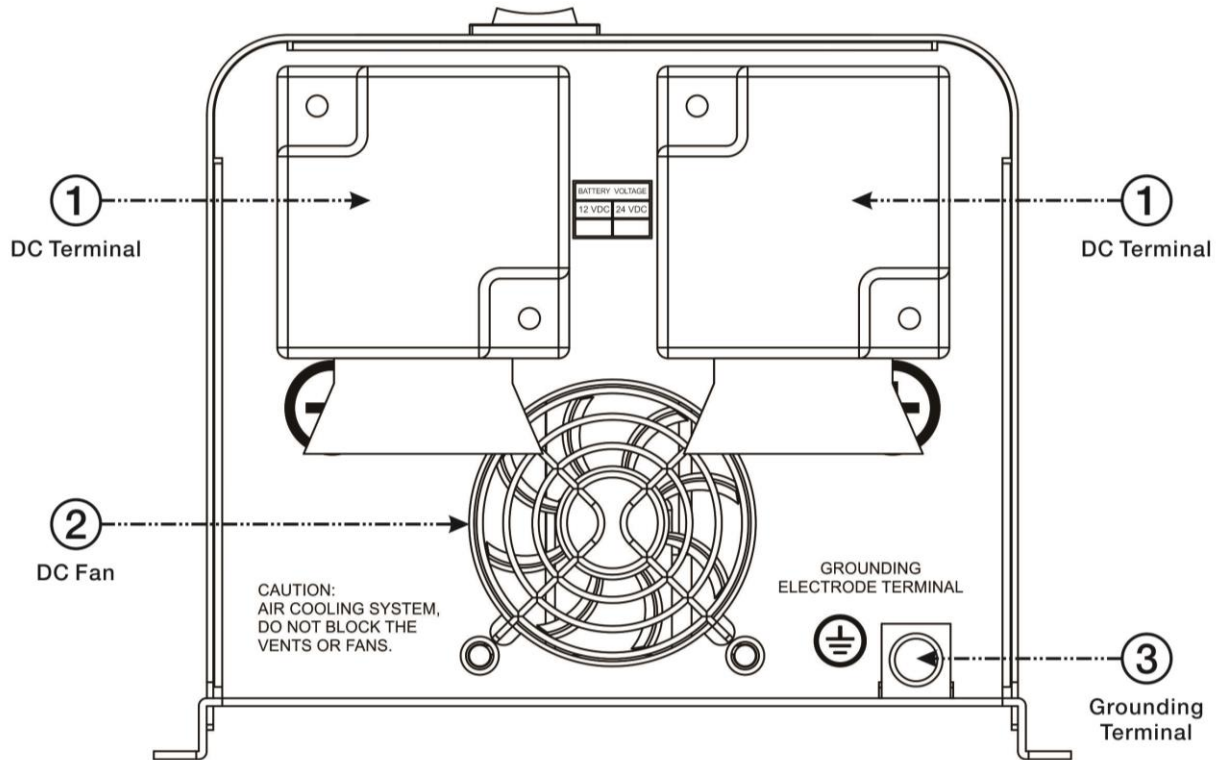

Figure 1

PICOGLF6W12V120V AC Side

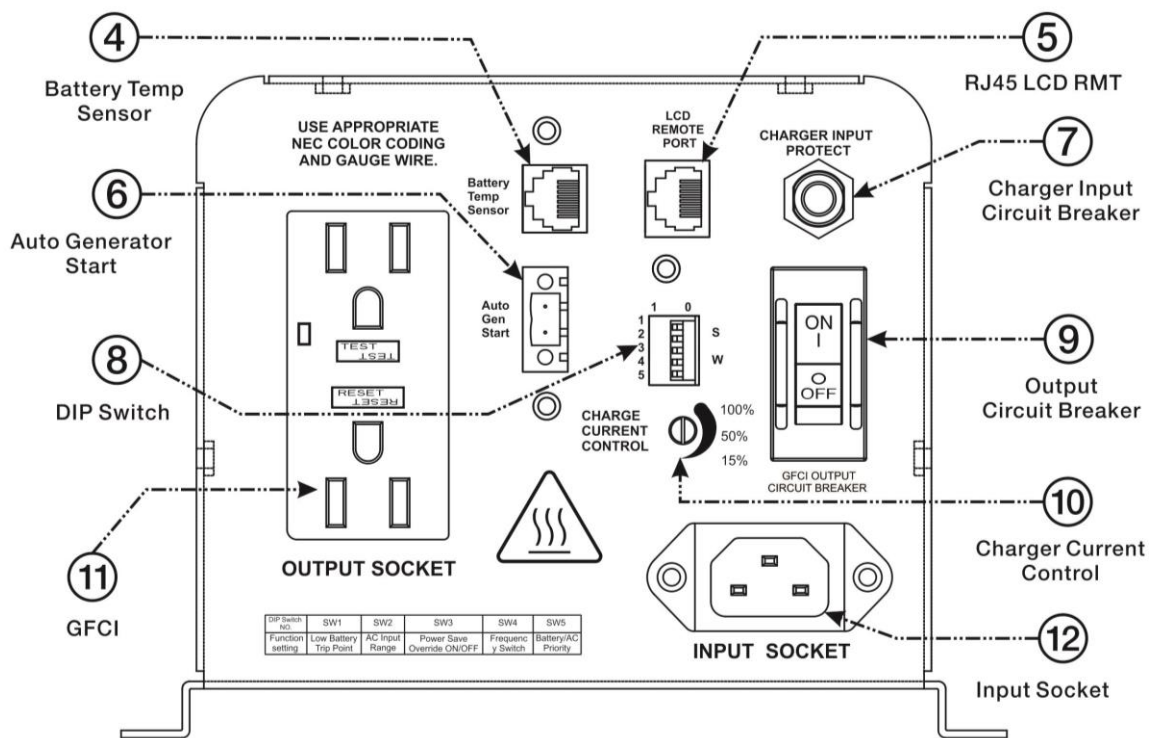

Figure 2

PICOGLF6W12V120V Side

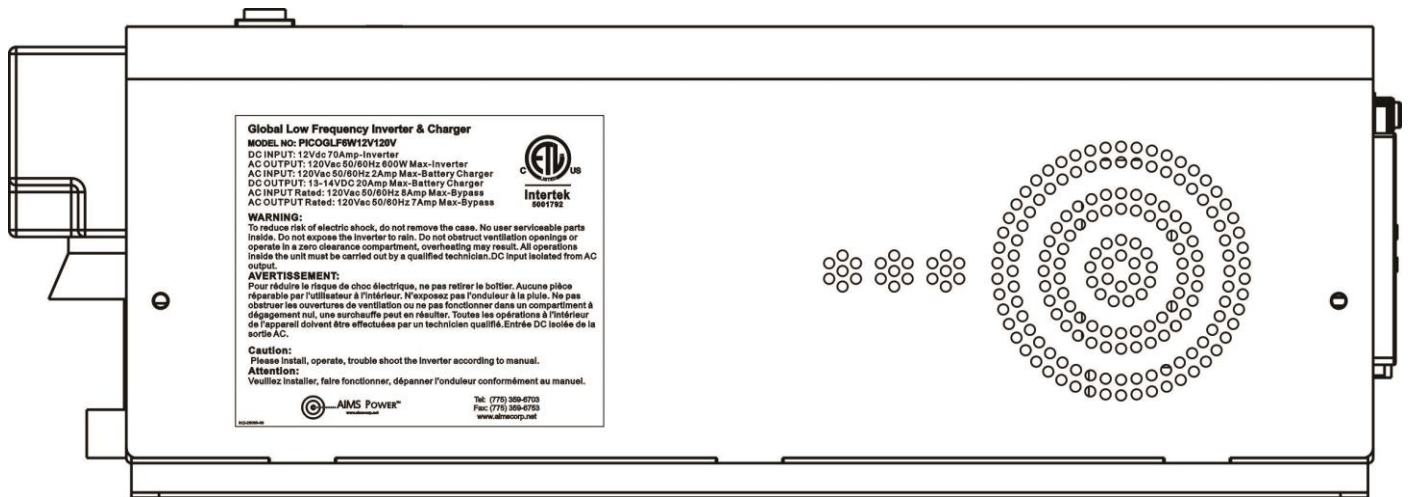

Figure 3

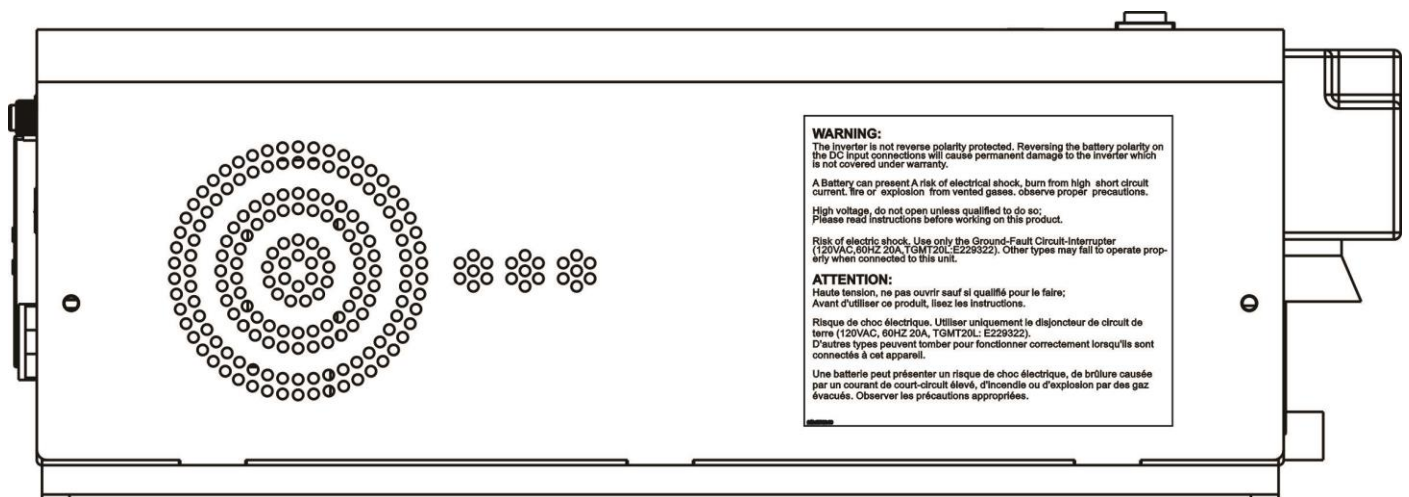

Figure 4

2.4 Features

- High overload ability up to 300% of rated power (20 sec)
- Low quiescent current, low power “Power Saving Mode” to conserve energy Automatic Generator Start
- Battery Temperature Sensing for more precise charging
- 4-step intelligent battery charger, PFC (Power Factor Correction) for charger 8 pre-set battery type selector switch plus de-sulphation for totally flat batteries
- Powerful charge rate of up to 20 Amps, selectable from 25%-100%
- 10 ms typical transfer time between battery and AC, guarantees power continuity Smart remote control
- 15s delay before transfer when AC resumes, extra protection for loads when used with generator Allows start up and through power with depleted batteries
- Multiple controlled cooling fans

- Extensive protections against various harsh situations
- 13VDC battery recovery point, dedicated for renewable energy systems

2.5 Electrical Performance

2.5.1 Inverter

Topology

The Global LF inverter/charger is built according to the following topology.

Invert: Full Bridge Topology.

Charge: Isolated Boost Topology

High efficiency mosfets and 16bit, 4.9MHZ microprocessor and heavy duty transformers outputs PURE SINE WAVE AC with an average THD of 8% (min 3%, max 10%) depending of load connected and the battery voltage.

The peak efficiency of the Global LF series is 80% and line mode is >95%.

Overload Capacity

The Global LF series inverters have high overload capacities, making it ideal to handle demanding loads.

1 For $110% < \text{Load} < 125% (\pm 10\%)$, no audible alarm for 14 minutes, beeps 0.5s every 1s in the 15th minute, and Fault(Turn off) after the 15th minute.

2 For $125% < \text{Load} < 150% (\pm 10\%)$, beeps 0.5s every 1s and Fault(Turn off) after 1 minute.

3 For $300% \cong \text{Load} > 150% (\pm 10\%)$, beeps 0.5s every 1s and Fault(Turn off) after 20s.

Caution:

After the inverter is switched on, it takes some time for it to self diagnose and ready to deliver full power. Hence, always switch on the load(s) after a few seconds of switching on the inverter. Avoid switching on the inverter with the load already switched on. This may prematurely trigger the overload protection. When a load is switched on, it may require initial higher power surge to start. Hence, if multiple loads are being powered, they should be switched on one by one so that the inverter is not overloaded by the higher starting surge if all the loads are switched on at once.

2.5.2 AC Charger

The Global LF Series is equipped with an active PFC (Power Factor Corrected) multistage battery charger. The PFC feature is used to control the amount of power used to charge the batteries in order to obtain a power factor as close as possible to 1.

Unlike other inverters whose max charging current decreases according to the input AC voltage, Global LF series charger is able to output max current as long as the input AC voltage is in the range of 95-127VAC for 120V model, and AC frequency is in the range of 48-54Hz(58-64Hz for 60Hz model).

The Global LF series inverter has a very rapid charge current available, and the max charge current can be adjusted from 25%-100% via a linear switch to the right of the battery type selector. This will be helpful if you are using our powerful charger on a small capacity battery bank. Fortunately, the linear switch can effectively reduce the max charging current to 25% of its peak.

Choosing "0" in the battery type selector will disable the charging function.



Caution:

Turn the charge current control switch gently to avoid breakage due to over-turning.

There are 3 charging stages:

Bulk Charging: (*fast charge LED solid*) This is the initial stage of charging. While Bulk Charging, the charger supplies the battery with controlled constant current. The charger will remain in Bulk charge until the Absorption charge voltage (determined by the Battery Type selection) is achieved.

A software timer will measure the time from A/C start until the battery charger reaches 0.3V below the boost voltage, then take this time as T_0 and $T_0 \times 10 = T_1$.

Absorb Charging: (*fast charge LED blinking*) This is the second charging stage and begins after the absorb voltage has been reached. Absorb Charging provides the batteries with a constant voltage and reduces the DC charging current in order to maintain the absorb voltage setting.

In this period, the inverter will start a T_1 timer; the charger will keep the boost voltage in Boost CV mode until the T_1 timer has run out. Then drop the voltage down to the float voltage. The timer has a minimum time of 1 hour and a maximum time of 12 hours.

Float Charging: (*float charge LED solid*) The third charging stage occurs at the end of the Absorb Charging time. While Float charging, the charge voltage is reduced to the float charge voltage (determined by the Battery Type selection*). In this stage, the batteries are kept fully charged and ready if needed by the inverter.

If the A/C is reconnected or the battery voltage drops below 12Vdc/24Vdc, the charger will restart the above cycle.

If the charge maintains the float state for 10 days, the charger will deliberately reset the cycle to protect the battery.

Battery Charging Processes

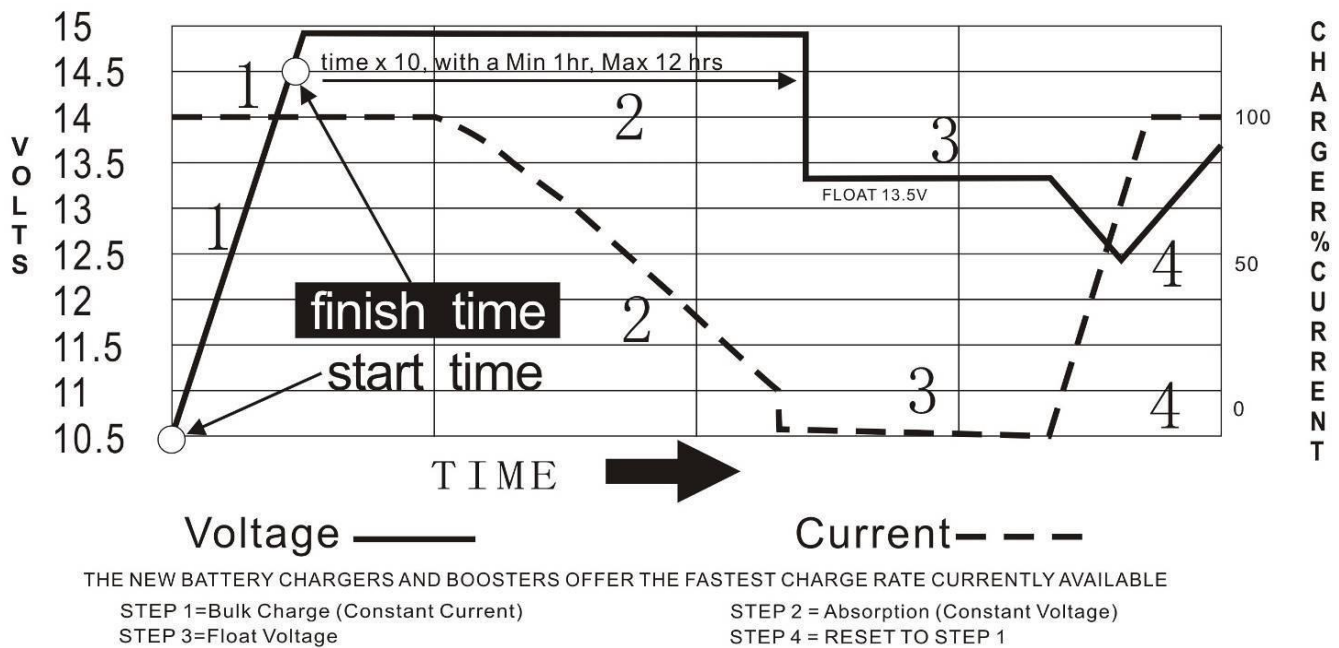

Figure 5

Battery type selector

Switch setting	Description	Boost / Vdc	Float / Vdc
0	Charger Off		
1	Gel USA	14.0	13.7
2	AGM 1	14.1	13.4
3	AGM 2	14.6	13.7
4	Sealed lead acid/LIFEPO4	14.4	13.6
5	Gel EURO	14.4	13.8
6	Open lead acid	14.8	13.3
7	Calcium	15.1	13.6
8	De-sulphation	15.5 (4 Hours then Off)	
9	Not used		

De-sulphation

The de-sulphation cycle, switch position 8, is marked in red because this is a very dangerous setting if you do not know what you are doing. Before attempting to use this cycle you must clearly understand what it does, when and how to use it.

What causes sulphation? This can occur with infrequent use of the batteries, or if the batteries have been discharged so low that they will not accept a charge. This cycle is a very high voltage charge cycle designed to try to break down the sulphated crust that is preventing the plates from taking a charge and thus allow the plates to clean up and accept a charge once again.

Charging depleted batteries

The Global LF series inverter allows start up and through power with depleted batteries.

For 12VDC models: after the battery voltage goes below 10V and the power switch is kept in the "ON" position and the inverter stays connected to the battery and the battery voltage doesn't drop below 2V, the inverter will be able to charge the battery once qualified AC inputs are present.

Before the battery voltage goes below 9VDC, the charging can be activated when the switch is turned to "Off", then to "ON".

When the voltage goes below 9VDC, and you accidentally turn the switch to OFF or disconnect the inverter from the battery, the inverter will not be able to charge the battery once again, because the CPU loses memory during this process.

Charging current for each model

Model	Current
PICOGLF6W12V120V	20+/-5A

The charging capacity will go to peak charge rate in about 3 seconds. This may cause a generator to drop frequency, making the inverter transfer to battery mode.

It is suggested to gradually put the charging load on the generator by switching the charging switch from min to max. Together with the 15s switch delay our inverter gives the generator enough time to spin up. This will depend on the size of the generator and rate of charge.

2.5.3 Transfer

While in the Standby Mode, the AC input is continually monitored. Whenever AC power falls below the VAC Trip voltage 90VAC for 120VAC, the inverter automatically transfers back to the Invert Mode with minimum interruption to your appliances - as long as the inverter is turned on. The transfer from Standby mode to Inverter mode occurs in approximately 10 milliseconds. And it is the same time from Inverter mode to Standby mode.

Though it is not designed as a computer UPS system, this transfer time is usually fast enough to keep your equipment powered up.

There is a 15-second delay from the time the inverter senses that continuously qualified AC is present at the input terminals to when the transfer is made. This delay is built in to provide time for a generator to spin-up to a stable voltage and avoid relay chattering. The inverter will not transfer to generator until it has locked onto the generator's output. This delay is also designed to avoid frequent switching when input utility is unstable.

2.5.4 Power Saver

There are 2 different working statuses for our Global LF inverter:

“Power On” and “Power Off”.

When the power switch is in “Unit Off” position, the inverter is powered off.

When the power switch is turned to either of “Power Saver Auto” or “Power Saver Off”, the inverter is powered on.

Power saver function is designed to conserve battery power when AC power is not or rarely required by the loads.

In this mode, the inverter pulses the AC output looking for an AC

load (i.e. electrical appliance). Whenever an AC load (greater than 25 watts) is turned on, the inverter recognizes the need for power and automatically starts inverting and output goes to full voltage. When there is no load (or less than 25 watts) detected, the inverter automatically goes back into search mode to minimize energy consumption from the battery bank.

In “Power saver on” mode, the inverter will draw power mainly in sensing moments, thus the idle consumption is significantly reduced.

The inverter is factory defaulted to detect a load for 250ms every 3 seconds with DIP switch 3 to position 1. This can be turned off when in position

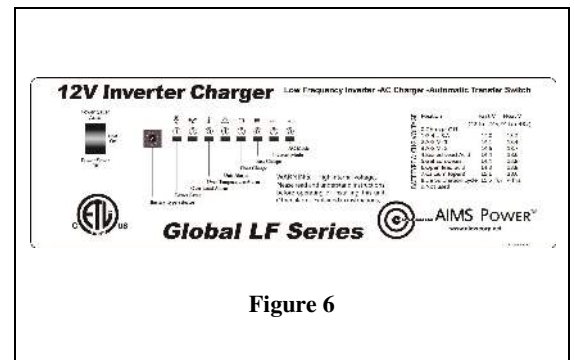
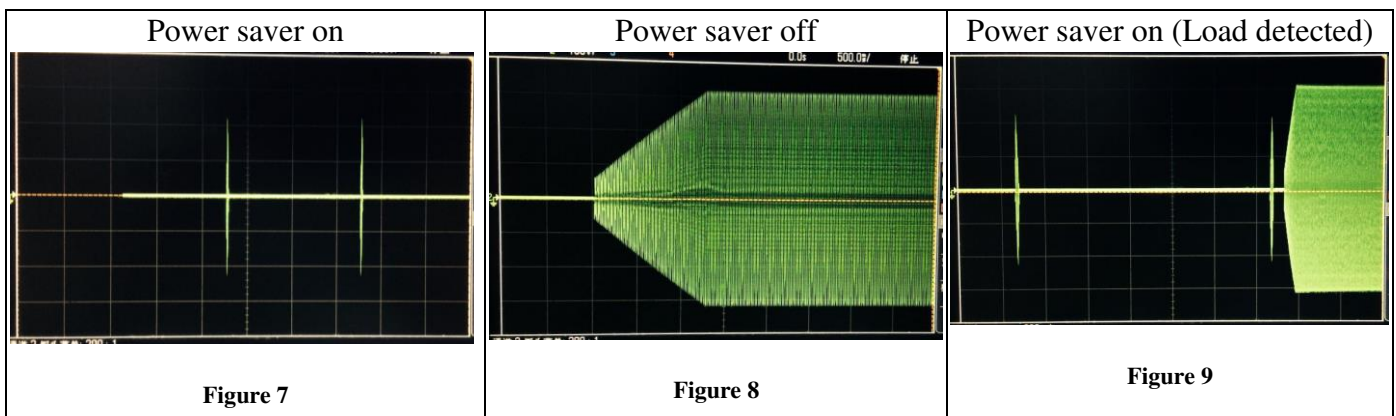

Figure 6



Note: The minimum power of a load to take inverter out of sleep mode (Power Saver On) is 25 Watts. The Global LF Series is designed with extraordinarily low idle power consumption which is only a mere 2-3 % of its rated power.

When in the search sense mode, the green power LED will blink and the inverter will make a ticking sound. At full output voltage, the green power LED will light steadily and the inverter will make a steady humming sound. When the inverter is used as an “uninterruptible” power supply the search sense mode or “Power Saver On” function should be defeated.

Exceptions

Some devices when scanned by the load sensor cannot be detected. Small fluorescent lights are the most common example. (Try altering the plug polarity by turning the plug over.) Some computers and sophisticated electronics have power supplies that do not present a load until line voltage is available. When this occurs, each unit waits for the other to begin. To drive these loads either a small companion load must be used to bring the inverter out of its search mode, or the inverter may be programmed to remain at full output voltage (Power On mode).

2.5.5 Protections

The Global LF series inverter is equipped with extensive protections against various harsh situations/faults. These protections include:

- AC Input over voltage protection/AC Input low voltage protection
- Low battery alarm/High battery alarm
- Over temperature protection/Over load protection
- Short Circuit protection (1s after fault)
- Back feeding protection

When Over temperature /Over load occur, after the fault is cleared, the master switch has to be reset to restart the inverter.

The Low battery voltage trip point can be customized from a defaulted value of 10VDC to 10.5VDC thru SW1 on the DIP switch.

The inverter will go to over temp protection when the heat sink temp $\geq 221^{\circ}\text{F}$, and go to Fault (shutdown Output) after 30 seconds. The switch needs to be reset to activate the inverter.

The Global LF series Inverter has back feeding protection which avoids presenting an AC voltage on the AC input terminal in Invert mode.

After the reason for the fault is cleared, the inverter needs to be reset to start working.

Peak Current 50Amp, duration 1 Second of peak and the 3 cycle RMS value is 100Vac.

2.5.6 Remote Control

Apart from the switch panel on the front (or top) side of the inverter, an extra LCD remote switch panel (Figure 11, sold separately Part #: REMOTELF) connected to the remote port at the DC side of the inverter through a standard Ethernet cable can also control the operation of the inverter.

If an extra switch panel is connected to the inverter via “remote control port”, together with the panel on the inverter case, the two panels will be connected and operated in parallel.

Whichever first switches from “Off” to “Power saver off” or “Power saver on”, it will power the inverter on.

If the commands from the two panels conflict, the inverter will operate according to the following priority: Power saver on > Power saver off > Power off

Only when both panels are turned to the “Unit Off” position, will the inverter be powered off.

The Max length of the LCD remote control data cable is 60 feet (18 meters).

The LCD remote control panel will display the operation status of the inverter, including:

- Input AC Voltage
- Output AC Voltage
- Battery Voltage
- Output Frequency
- Output Load
- Work Mode
- Alarm
- Fault
- Battery Capacity

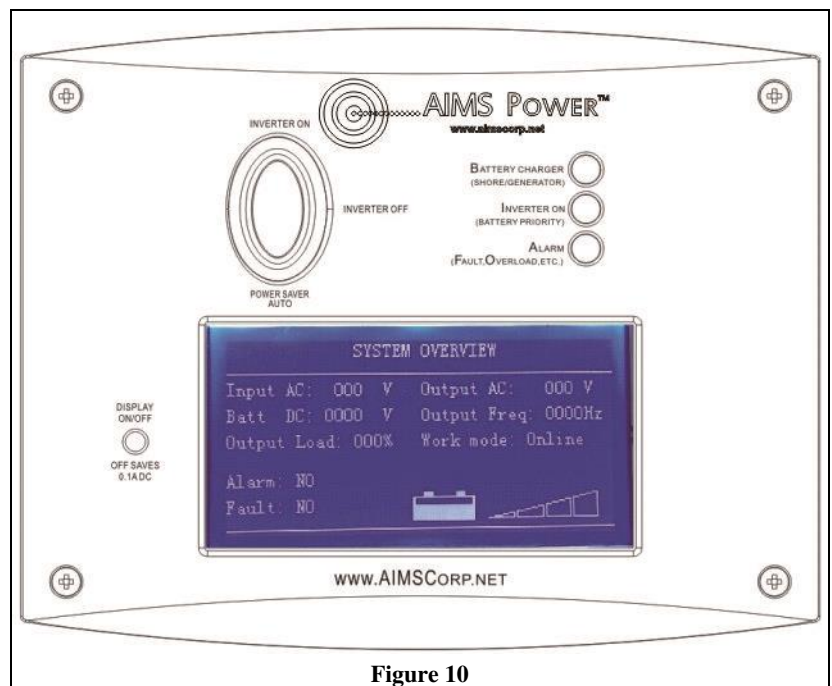

Figure 10

A push button on the left of the panel can be used to turn off the LCD screen and save 0.1A current draw on the battery.



WARNING

Never cut the telephone cable when the cable is attached to inverter and battery is connected to the inverter. Even if the inverter is turned off, it will damage the remote PCB inside if the cable is short circuited during cutting.

2.5.7 LED Indicator

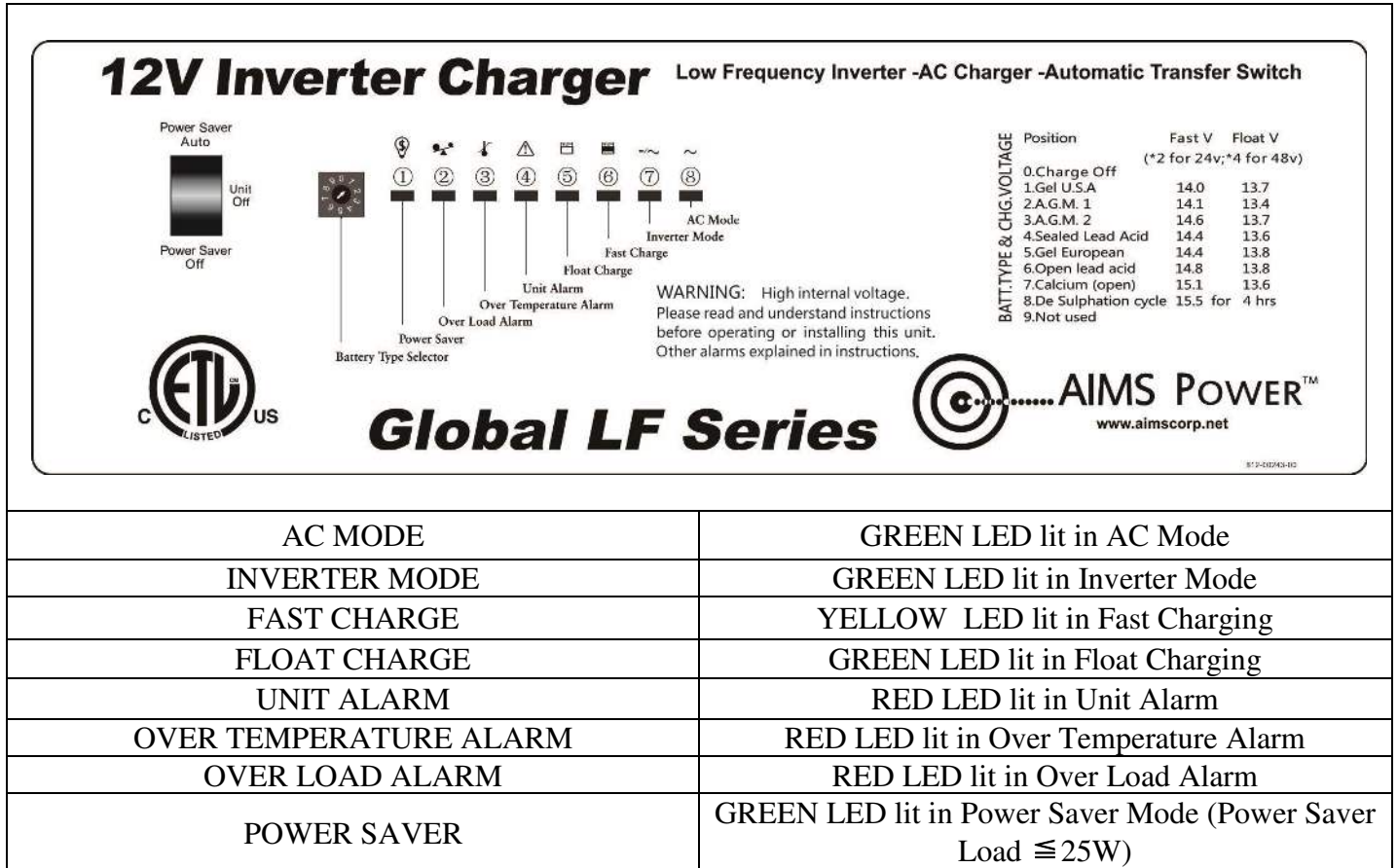
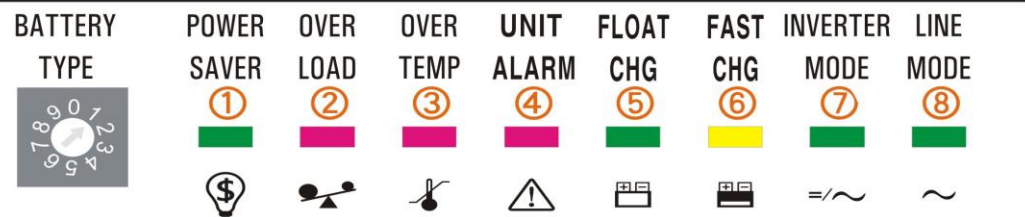

Figure 11

Status Center



LED STATUS AND FAULT

Status	L.E.D.s Function	L.E.D.s on main unit								L.E.D.s on remote Alarm		
		①	②	③	④	⑤	⑥	⑦	⑧	①	②	③
Charge function	Constant current charge							on	on			on
	Constant voltage charge							flash	on			on
	Float Standby					on			on			on
Inverter mode	Inverter on							on				on
	Power saver on	on										
Alarms	Battery low voltage				on			on		beep 0.5 s every 5 s		on on
	Battery high voltage				on			on		beep 0.5 s every 5 s		on on
	Over load (inverter mode)		on		on			on		beep 0.5 s every 5 s		on on
	Over temp (inverter mode)			on	on			on		beep 0.5 s every 5 s		on on
	Over temp (line mode)			on	on	on			on	beep 0.5 s every 5 s	on	on
Fault mode	Over charge				on	on		on		beep 0.5 s every 5 s	on	on
	Fan lock									beep continuous		
	Battery high voltage							on		beep continuous		on
	Inverter mode overload		on							beep continuous		
	Over temperature		on							beep continuous		

Figure 12

2.5.8 Audible Alarm

Battery Voltage Low	Inverter green LED lit, and the buzzer beeps 0.5s every 5s.
Battery Voltage High	Inverter green LED lit, and the buzzer beeps 0.5s every 1s and Fault after 60s.
Invert Mode Over-Load	(1) 110% < load < 125% ($\pm 10\%$), No audible alarm in 14 minutes, Beeps 0.5s every 1s in 15 th minute and Fault after 15 minutes; (2) 125% < load < 150% ($\pm 10\%$), Beeps 0.5s every 1s and Fault after 60s; (3) Load > 150% ($\pm 10\%$), Beeps 0.5s every 1s and Fault after 20s;
Over Temperature	Heat sink temp. $\geq 221^{\circ}\text{F}$, Over temp red LED Lighting, beeps 0.5s every 1s;

2.5.9 FAN Operation

There is one multiple controlled DC fan which starts to work according to the below logic. The Operation of the DC fan at the DC terminal side is controlled by the following logic:

Condition	Enter Condition	Leave condition	Speed
HEAT SINK TEMPERATURE	$T \leq 60^{\circ}\text{C}$ 140°F	$T > 65^{\circ}\text{C}$ 149°F	OFF
	$149^{\circ}\text{F} \leq T < 185^{\circ}\text{F}$	$T \leq 140^{\circ}\text{F}$ or $T \geq 185^{\circ}\text{F}$	50%
	$T > 85^{\circ}\text{C}$ 185°F	$T 80^{\circ}\text{C} \leq 176^{\circ}\text{F}$	100%
CHARGER CURRENT	$I \leq 15\%$	$I \geq 20\%$	OFF
	$20\% < I \leq 50\% \text{Max}$	$I \leq 15\%$ or $I > 50\% \text{Max}$	50%
	$I > 50\% \text{Max}$	$I \leq 40\% \text{Max}$	100%
LOAD Percentage (INV MODE)	Load < 30%	Load $\geq 30\%$	OFF
	$30\% \leq \text{Load} < 50\%$	Load $\leq 20\%$ or Load $\geq 50\%$	50%
	Load $\geq 50\%$	Load $\leq 40\%$	100%

Allow at least 30CM of clearance around the inverter for air flow. Make sure that the air can circulate freely around the unit.

Fan noise level <60db at a distance of 3 feet

2.5.10 DIP Switches

On the DC end of inverter, there are 5 DIP switches which enable users to customize the performance of the device.

Switch NO	Switch Function	Position: 0	Position: 1
SW1(Utility Priority)	Low Battery Trip Point	10.0VDC	10.5VDC
SW1(Battery Priority)		10.5VDC	11.5VDC
SW2	AC Input Range	100-135VAC	90-135VAC(40-70Hz)
SW3	Power Save Override	Inverter Off	Saver On 3 sec
	ON/OFF		

SW4	Frequency Switch	50Hz	60Hz
SW5	Battery/AC Priority	AC Priority	Battery Priority

Low Battery Trip Point(SW1):

Deep discharge of the lead acid battery leads to high losses in capacity and early aging. In different applications a different low voltage disconnection level is preferred. For example, for solar applications, user may intend to have less DOD to prolong the battery life cycle. While for mobile applications users may intend to have more DOD to reduce battery capacity and on-board weight.

For 12VDC models, when the inverter is in utility priority mode (SW5 at “0”), Low Battery Trip Point is selectable at 10.0/10.5VDC. It can be customized to 10.5/11.5VDC via SW5. This is to prevent batteries from over-discharging while there is only a small load applied on the inverter.

AC Input Range(SW2):

There are different acceptable AC input ranges for different kinds of loads.

For some relatively sensitive electronic devices, a narrow input range of 100-135V is required to protect them.

While for some resistive loads which work in a wide voltage range, the input AC range can be customized to 90-135V for 120VAC , this helps to power loads with the most AC input power without frequent switches to the battery bank.

In order to make the inverter accept dirty power from a generator, when the SW2 is switched to position “1”, the inverter will bypass an AC input with a wider voltage and frequency (40-70Hz for 50Hz/60Hz).

Accordingly, the AC charger will also work in a wider voltage and freq range (42-68Hz for 50Hz/60Hz).

This will avoid frequent switches between battery and generator. But some sensitive loads will suffer from the low quality power.

The pros and cons should be clearly realized.

Power Save Override ON/OFF (SW3):

Under the Battery Priority Mode (SW5 in position “1”), the inverter can be switched between two modes: Power Saver Mode (SW3 in position “1”) and Unit Off Charging Mode (SW3 in position “0”). The power Switch should be in “Power saver on” position all the time for using these functions.

In Power Saver Mode, the inverter is initially in standby mode and sends a pulse to detect the presence of a load every 3 seconds. Each pulse lasts for 250ms. The inverter will remain in standby mode until a load has been detected. Then it will wake up from standby mode and start to invert electricity from the battery bank to supply the load. As this function is under Battery Priority, the inverter will always prefer to invert electricity from battery first even there is a qualified AC input present. Only when the battery voltage is lower than the low voltage alarm point, will the inverter switch to AC input power to charge the battery and supply the load at the same time.

This Power Saver Mode can be changed to Unit Off Charging mode via SW3 by switching it to “0” position. (SW5 still in “1”)

In Unit Off Charging mode, the inverter will stay in standby mode without sensing loads. It will not output any power even if a load is turned on or a qualified AC input is present. The inverter will not perform any function and only stay idle in this mode, unless the battery voltage is low. Then it will start charging the battery. This feature is ideally suitable for applications where energy conservation is required. Charging will only be activated when required.

Frequency Switch(SW4):

The output frequency of the inverter can be set at either 50Hz or 60Hz by SW4.

AC/Battery Priority(SW5):

Our inverter is designed with AC priority by default. This means, when AC input is present, the battery will be charged first, and the inverter will transfer the input AC to power the load. Only when the AC input is stable for a continuous period of 15 days will the inverter start a battery inverting cycle to protect the battery. After 1 normal charging cycle ac through put will be restored.

The AC Priority and Battery Priority switch is SW5. When you choose battery priority, the inverter will invert from battery despite the AC input. Only when the battery voltage reaches the low voltage alarm point 10.5Vdc for 12V DC will the inverter transfer to AC Input, charge battery, and switch back to battery when the battery is fully charged. This function is mainly for wind/solar systems using utility power as back up.

Note: In battery priority mode, when qualified AC inputs for the first time and the battery voltage is below 12.5V DC, the inverter will go into battery priority mode only after a cycle of bulk charging and absorb charging is finished. The inverter will not go into float charging mode.

2.5.11 Battery Temperature Sensing

Applying the proper charge voltage is critical for achieving optimum battery performance and longevity. - The ideal charge voltage required by batteries changes with battery temperature.

The battery temperature sensor allows the charge controller to continuously adjust charge voltage based on actual battery temperature.

Temperature compensation of charge voltage assures that the battery receives the proper charge voltage as battery temperature varies.

The entire line is equipped with Battery Temperature Sensing for increased charging precision.

It sends precise information to the charger, which automatically adjusts voltage to help ensure full battery charge depending on the ambient temperature of your battery installation.

When the battery temperature is over 40°C (104°F), it will reduce the charging voltage by 0.1Vdc with every degree of temperature rise.

We recommend that you install Battery Temperature Sensors on all banks to protect your batteries and to provide optimal charging of each bank.

The battery temperature sensor mounts on the side of a battery or any other location where the precise temperature of battery can be detected such as battery mounting racks.

The following table describes approximately how much the voltage may vary depending on the temperature of the batteries.

Inverter Condition	Temperature on BTS	Charger Operation
Charger Mode	$BTS \geq 50^{\circ}\text{C} (122^{\circ}\text{F})$	Automatically turns off charger
	$BTS \leq 40^{\circ}\text{C} (104^{\circ}\text{F})$	Automatically turns on charger
Inverter Mode	$40^{\circ}\text{C} (104^{\circ}\text{F}) \leq BTS \leq 50^{\circ}\text{C} (122^{\circ}\text{F})$	Increases low voltage shut down point by 0.5Vdc
	$BTS \geq 50^{\circ}\text{C} (122^{\circ}\text{F})$	Over Temp Fault

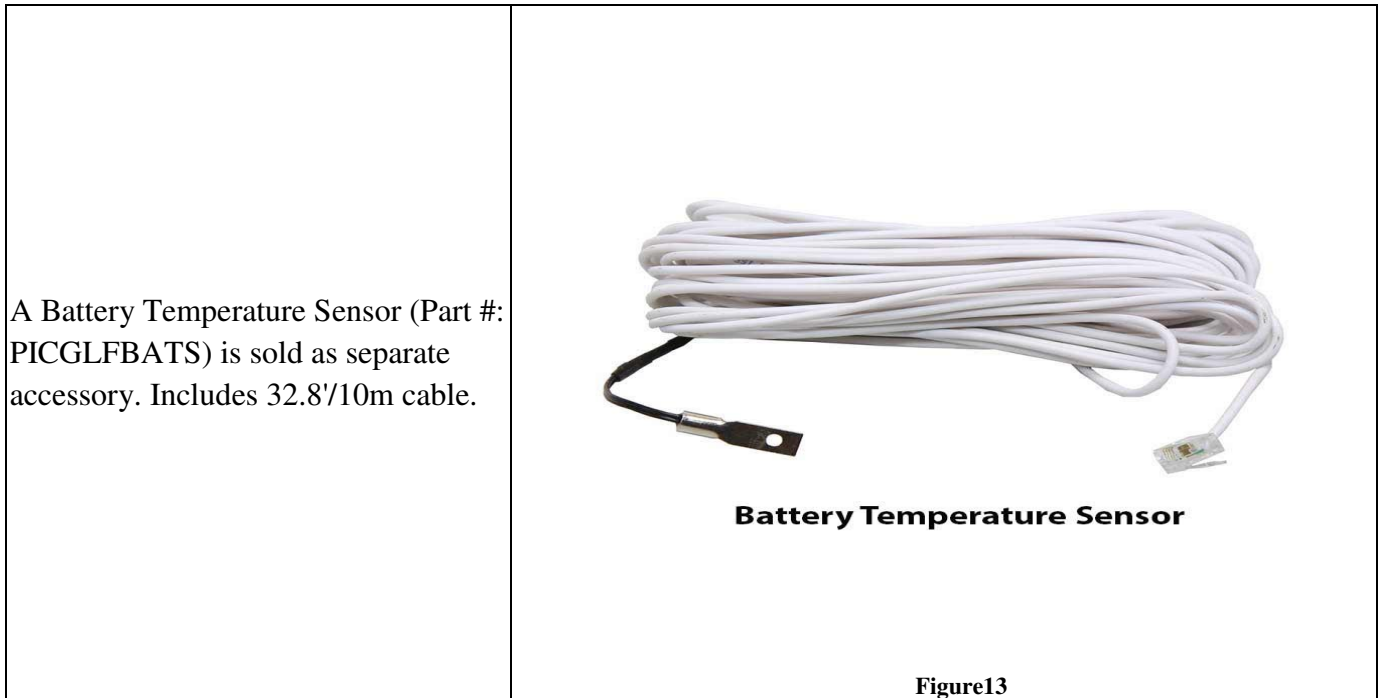

Important: If the battery temperature drops to extremely cold temperatures, the inverter with a BTS may not be able to properly recharge cold batteries due to maximum voltage limits of the inverter. Ensure the batteries are protected from extreme temperatures.

For more detailed technical information, please contact us.

2.5.12 Auto Generator Start

The inverter can start up generator when battery voltage goes low.

When the inverter goes to low battery alarm, it can send a signal to start a generator and turn the generator off after battery charging is finished.

The auto gen start feature will only work with generators which have automatic starting capability.

The generator must have start and stop controls [i.e., an electric starter and electric choke (for gasoline units)], and the safety sensors to be able to start and stop automatically.

There is an open/close relay that will short circuit the positive and negative cables from a generator start control.

The input DC voltage can vary, but the max current the relay can carry is 16Amp.

The Auto Generator Start terminal pins are not polarized.

In addition, these two pins can also be used as dry contacts to send out “Low Battery Voltage” signal to an external alarm device.

2.5.13 Other Features

Battery voltage recovery start

After low battery voltage shut off (10V for 12V model), the inverter is able to restore operation after the battery voltage recovers to 13V (with power switch still in the “On” position). This function helps to save the users extra labor to reactivate the inverter when the low battery voltage returns to an acceptable range in renewable energy systems. The built-in battery charger will automatically reactivate as soon as city/generator ac has been stable for 15 seconds.



WARNING

Never leave the loads unattended, some loads (like a heater) may cause accidents in such cases. It is better to shut everything off after low voltage trip than to leave your load on, due to the risk of fire.

The inverter is not reverse polarity protected. Reversing the battery polarity on the DC input connections will cause permanent damage to the inverter which is not covered under warranty.

A Battery can present A risk of electrical shock, burn from high short circuit current. fire or explosion from vented gases. observe proper precautions.

High voltage, do not open unless qualified to do so;
Please read instructions before working on this product.

Risk of electric shock. Use only the Ground-Fault Circuit-Interrupter (120VAC,60HZ 20A,TGMT20L:E229322). Other types may fall to operate properly when connected to this unit.



ATTENTION:

Haute tension, ne pas ouvrir sauf si qualifié pour le faire;
Avant d'utiliser ce produit, lisez les instructions.

Risque de choc électrique. Utiliser uniquement le disjoncteur de circuit de terre (120VAC, 60HZ 20A, TGMT20L: E229322).

D'autres types peuvent tomber pour fonctionner correctement lorsqu'ils sont connectés à cet appareil

Conformal Coating

AIMS Power entire line of Global LF inverters have been processed with a conformal coating on the PCB, making it water, rust, dust and corrosion resistant.

While these units are designed to withstand corrosion from the salty air, they are not splash proof.

3. Installation

* All wiring must follow the National Electric Code, Install shall be in accordance with the Canadian Electrical Code Part 1

3.1 Location

Follow all the local regulations to install the inverter.

Install the equipment in a location that is dry, clean, cool with good ventilation.

Working temperature: -10°C- 50°C(-14°Fto 122°F)

Storage temperature: -40-70°C(-40°Fto 158°F)

Relative Humidity: 0% to 95%, non-condensing

Cooling: Forced air

3.2 DC Wiring

It is suggested the battery bank be kept as close as possible to the inverter. The following is a suggested wiring option for 3 feet DC cable.

The chart below provides wire size recommendation up to 10 feet. If the application requires a longer run, use larger cables.

*Installer to use protection not less than the short circuit current

Output Power	DC Input voltage	Wire Gage
600W	12V	8 AWG

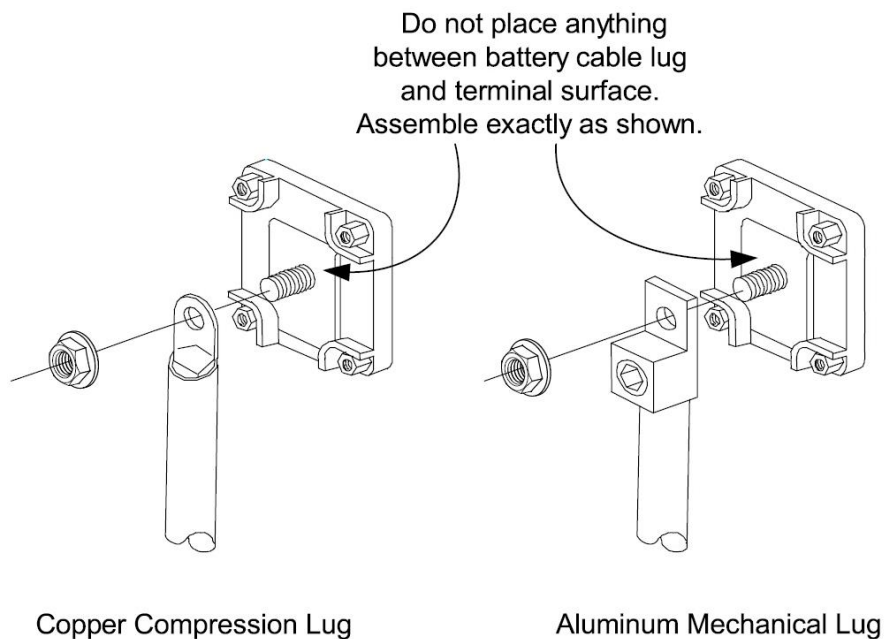

Figure 14

**CAUTION**

The torque rating range for DC terminal is 12.5NM-20.5NM, and the suggested torque rating is 17NM. Over torquing may cause the bolt to break.

**WARNING**

In the event of reverse polarity the unit could be totally destroyed and warranty voided!
When replacing batteries, use the same number and type of batteries!
Proper disposal of batteries is required, refer to your local codes for disposal requirements!

3.3 AC Wiring

The AC wiring of the 600W inverter is easy. Just plug the AC input cable to the shore power and connect loads to the GFCI output.

**WARNING**

The output voltage of this unit must never be connected in its input AC terminal, overload or damage may result.

Always switch on the inverter before plugging in any appliance.

3.4 Grounding

Connect an 8 AWG gauge or greater copper wire between the grounding terminal on the inverter and the earth grounding system or the vehicle chassis.

3.5 Install Flange

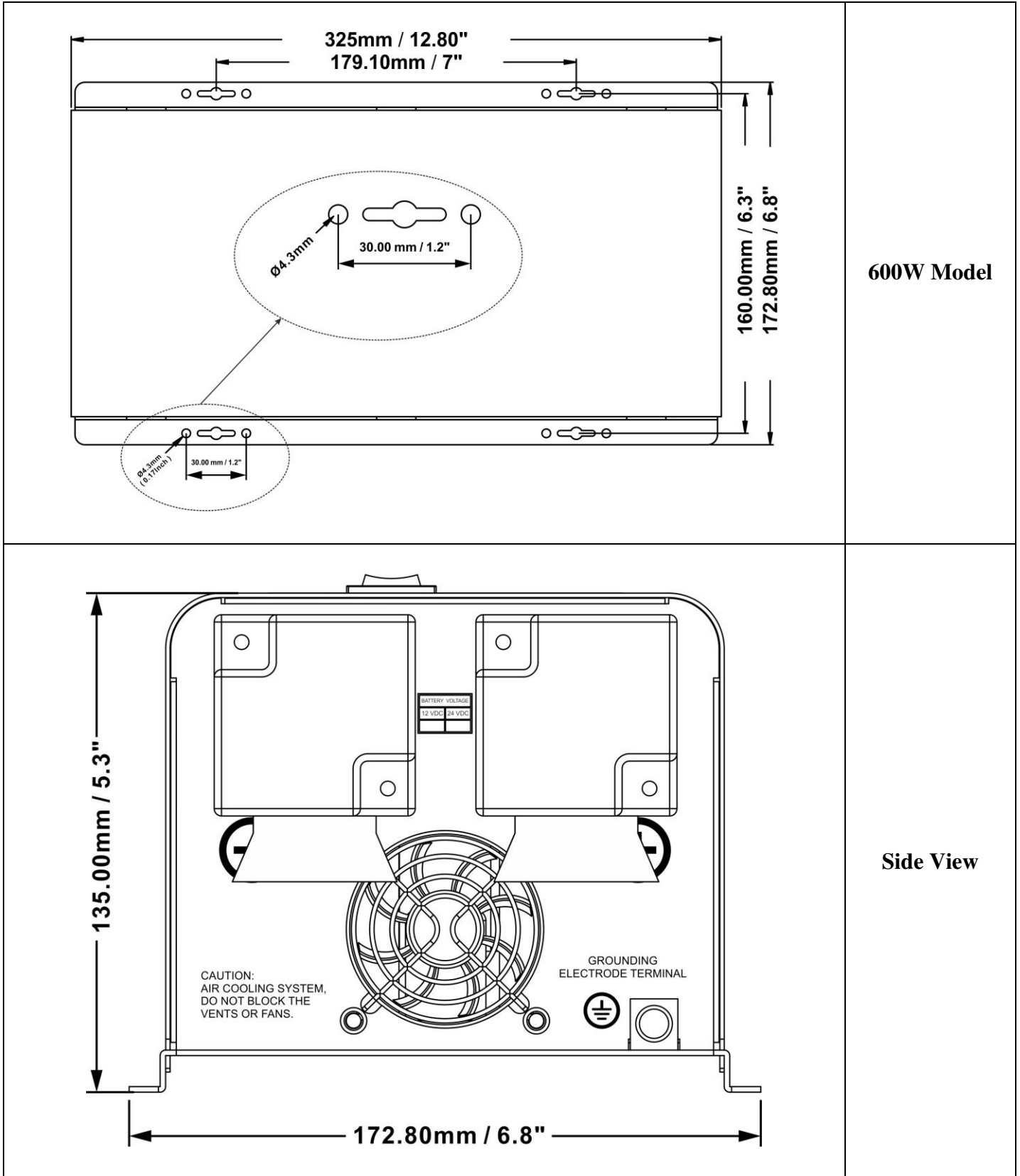

600W Model

Side View

4. Troubleshooting Guide

Troubleshooting contains information about how to troubleshoot possible error conditions while using the Global LF Inverter & Charger.

The following chart is designed to help you quickly pinpoint the most common inverter failures.

Indicator and Buzzer

Status	Item	Indicator on top cover								
		AC MODE	INVERTER MODE	FAST CHARGE	FLOAT CHARGE	UNIT ALARM	OVER TEMPERATURE ALARM	OVER LOAD ALARM	POWER SAVER	BUZZER
Line Mode	CC	√	×	√	×	×	×	×	×	×
	CV	√	×	√, blink	×	×	×	×	×	×
	Float	√	×	×	√	×	×	×	×	×
	Standby	√	×	×	×	×	×	×	×	×
Inverter Mode	Inverter On	×	√	×	×	×	×	×	×	×
	Power Saver	×	×	×	×	×	×	×	√	×
	Low Battery	×	√	×	×	√	×	×	×	Beep 0.5s every 5s
	High Battery	×	√	×	×	√	×	×	×	Beep 0.5s every 1s
	Overload Invert Mode	×	√	×	×	√	×	√	×	Refer to “Audible alarm”
	Over-Temp Invert Mode	×	√	×	×	√	√	×	×	Beep 0.5s every 1s
	Over-Temp Line Mode	√	×	√	×	√	√	×	×	Beep 0.5s every 1s
	Over Charge	√	×	√	×	√	×	×	×	Beep 0.5s every 1s
Fault	Fan Lock	×	×	×	×	×	×	×	×	Beep continuous
	Battery High	×	√	×	×	×	×	×	×	Beep continuous
	Overload Invert Mode	×	×	×	×	×	×	√	×	Beep continuous
	Output Short	×	×	×	×	√	×	√	×	Beep continuous
	Over-Temp	×	×	×	×	×	√	×	×	Beep continuous
	Over Charge	×	×	√	×	×	×	×	×	Beep continuous
	Back Feed Short	×	×	×	×	×	×	×	×	Beep continuous

Symptom	Possible Cause	Recommended Solution
Inverter will not turn on during initial power up.	Batteries are not connected, loose battery-side connections. Low battery voltage.	Check the batteries and cable connections. Check DC fuse and breaker. Charge the battery.
No AC output voltage and no indicator lights ON.	Inverter has been manually transitioned to OFF mode.	Press the switch to Power saver on or Power saver off position.
AC output voltage is low and the inverter turns loads OFF in a short time.	Low battery.	Check the condition of the batteries and recharge if possible.

Charger is inoperative and unit will not accept AC.	AC voltage has dropped out-of-tolerance	Check the AC voltage for proper voltage and frequency.
Charger is supplying a lower charge rate.	Charger controls are improperly set. Low AC input voltage. Loose battery or AC input connections.	Refer to the section on adjusting the "Charger Rate". Source qualified AC power. Check all DC /AC connections.
Charger turns OFF while Charging from a generator.	High AC input voltages from the generator.	Load the generator down with a heavy load. Turn the generator output voltage down.
Sensitive loads turn off temporarily when transferring between grid and inverting.	Inverter's Low voltage trip voltage may be too low to sustain certain loads.	Choose narrow AC voltage in the DIP switch, or Install a UPS if possible.
Noise from Transformer/case*	Applying specific loads such as hair drier	Remove the loads

***The reason for the noise from transformer and/or case**

When in inverter mode sometimes the transformer and/or case of the inverter may vibrate and make noise. If the noise comes from transformer:

According to the characteristics of our inverter, there is one type of load which most likely may cause rattles of transformer.

That is a half wave load: A load that uses only half a cycle of the power. This tends to cause an imbalance of the magnetic field of the transformer, reducing its rated working freq from 20KHz to, say, maybe 15KHz (it varies according to different loads). In such a case the frequency of noise falls exactly into the range (200Hz-20KHz) that human ears can hear.

The most common load of such kind is a hair dryer. If the noise comes from the case:

Normally when loaded with inductive loads, the magnetic field generated by the transformer keeps attracting or releasing the steel case at a specific frequency, this may also cause noise.

Reducing the load power or using an inverter with bigger capacity will normally solve this problem.

The noise will not do any harm to the inverter or the loads.

5 Limited Warranty

AIMS Operating Corp., Inc. dba AIMS Power Warranty Instructions:

This product is designed using the most modern digital technology and under very strict quality control and testing guide lines. If, however you feel this product is not performing as it should, please contact us:

techsupport@aimscorp.net or (775)359-6703.

We will do our best to resolve your concerns. If the product needs repair or replacement, make sure to keep your receipt/invoice, as that will need to be sent back along with the package and RA# prepaid to AIMS.

You have a full 2 year from date of purchase warranty.

This warranty is valid worldwide with the exception that freight and duty charges incurred outside the contiguous 48 United States will be prepaid by customer.

Except as provided above, AIMS makes no warranty of any kind, express or implied, including without limitation the implied warranties of merchantability and fitness for a particular purpose. In no event shall AIMS be liable for indirect, special or consequential damages. This warranty only applies to AIMS Power branded products. All other name brand products are warranted by and according to their respective manufacturer. Please do not attempt to return non-AIMS Power branded products to AIMS Power.

For additional products such as:

- Modified sine wave inverters
- Pure sine wave inverters
- Solar Charge Controllers
- On Grid Inverters
- Inverter Chargers and Automatic transfer switches
- Custom cut cables
- Batteries
- Solar Panels

Please visit our web site: www.aimscorp.net

Product Registration Instructions

Please visit our website at www.AIMSCorp.net and click on the product registration link at the top of the page.

This will validate your warranty with AIMS Power and ensure that you get fast, expedited customer service if you need to repair or exchange your product.



Appendix 1

Global LF Series Inverter & Charger Spec Sheet			
Electrical Specifications			
Inverter Output	Power Rating	600W	
	Continuous Output Power	600W	
	Surge Rating(20s)	1800W	
	Output Waveform	Pure Sine wave/Same as input(Bypass mode)	
	Nominal Efficiency	80%(Peak)	
	Line Mode Efficiency	>95%	
	Power Factor	0.9-1.0	
	Nominal Output Voltage RMS	120Vac	
	Output Voltage Regulation	±10% RMS	
	Output Frequency	50/60Hz ± 0.3Hz	
	Short Circuit Protection	Yes, Current Limit Function (Fault after 1sec)	
	Typical transfer Time	6-8ms,10ms(Max)	
	THD	Typically<3%, Max 10% under full linear load	
DC Input	Nominal Input Voltage	12.0Vdc	
	Minimum Start Voltage	10.0Vdc	
	Low Battery Alarm	10.5Vdc / 11.0Vdc	
	Low Battery Trip	10.0Vdc / 10.5Vdc	
	High Voltage Alarm & Fault	16.0Vdc	
	High DC Input Recovery	15.5Vdc	
	Low Battery Voltage Recover	13.0Vdc	
	Idle Consumption-Search Mode	< 25 W when Power Saver On	
AC Charge	Input Voltage Range	Narrow: 100~135VAC;	
		Wide: 90~135VAC ;	
	Input Frequency Range	Narrow: 47-55±0.3Hz for 50Hz, 57-65±0.3Hz for 60Hz	
		Wide:40-70±0.3Hz for 50Hz/60Hz	
	Output Voltage	Depends on battery type	
	Charger Breaker Rating(120Vac)	7A	
	Max Charge Rate	20A to 25A +/-5A , depending on models	
	Over Charge Protection Shutdown	15.7V for 12Vdc	
	Battery type	Fast Vdc	Float Vdc
	Gel U.S.A	14	13.7
	A.G.M 1	14.1	13.4
	A.G.M 2	14.6	13.7
	Sealed Lead Acid	14.4	13.6
Gel Euro	14.4	13.8	
Open Lead Acid	14.8	13.3	

	Calcium	15.1	13.6
	De-sulphation	15.5 for 4hrs	
	Remote Control	Yes. Optional	
Bypass & Protection	Input Voltage Waveform	Sine wave (Grid or Generator)	
	Nominal Voltage	120Vac	
	Low Voltage Trip	80V/90V±4%	
	Low Voltage re engage	90V/100V±4%	
	High Voltage Trip	140V±4%	
	High Voltage re engage	135V±4%	
	Max Input AC Voltage	150VAC	
	Nominal Input Frequency	50Hz or 60Hz (Auto detect)	
	Low Freq Trip	Narrow: 47±0.3Hz for 50Hz, 57±0.3Hz for 60Hz	
		Wide:40±0.3Hz for 50Hz/60Hz	
	Low Freq re engage	Narrow: 48±0.3Hz for 50Hz, 58±0.3Hz for 60Hz	
		Wide:42±0.3Hz for 50Hz/60Hz	
	High Freq Trip	Narrow: 55±0.3Hz for 50Hz, 65±0.3Hz for 60Hz	
		Wide: 70Hz for 50Hz/60Hz	
High Freq re engage	Narrow: 54±0.3Hz for 50Hz, 64±0.3Hz for 60Hz		
	Wide: 68Hz for 50Hz/60Hz		
Mechanical Specification	Mounting	Wall mount	
	Inverter Dimensions(L*W*H)	325*173*135mm/12.8*6.8*5.3"	
	Inverter Weight	7.5KG/16.5lb	
	Shipping Dimensions(L*W*H)	475*230*205mm/18.7*9*8"	
	Shipping Weight	8.5KG/18.7lb	
	Display	Status LED	

※Specifications in this manual are subject to change without prior notice.

