

## 120W MIL-COTS , 9 to 40V Input Isolated Quarter Brick

<https://product.tdk.com/en/power/hqa>  
[www.emea.lambda.tdk.com/HQA](http://www.emea.lambda.tdk.com/HQA)



The HQA series of isolated DC-DC converters bring a high performance quarter brick in a rugged-encapsulated package for MIL-COTS applications. With its high efficiency performance, magnetic feedback loop and wide operating baseplate temperatures of -55 to 115°C (-40°C for -S suffix), it provides high useable power at elevated temperatures and altitude for demanding and harsh environments. Various MIL-STD compliance can be supported when paired with the FQA or FQB MIL-COTS input filters.

Features	Benefits
• Up to 120 W in an Industry Quarter Brick package	• High Power Density, Less Board Area Needed
• Encapsulated and Rugged design	• Operation in Harsh and Demanding Environments
• Maximum Baseplate Temperature of 115°C	• High Useable Power at Elevated Temperatures
• No Optocouplers used	• Increased Reliability in High Altitude
• Enhanced Screening Option (-M Suffix)	• Reduces End System Test Screening Requirement
• Designed to meet MIL-STD-461; MIL-STD-1275; MIL-STD-704; RTCA/DO-160 Sec 16-18 with FQA / FQB Input Filters	• Facilitates Compliance to Various MIL-STD

Model Selector							
Model	Input Voltage (V)	Output Voltage (V)	Max Current (A)	Max Power (W)	Remote Sense	Baseplate	Screening
<a href="#">HQA2W120W050V-007-S</a>	9 - 40	5	24	120	Yes	Flanged	-S : Standard
<a href="#">HQA2W120W050V-N07-M</a>	9 - 40	5	24	120	Yes	Non-Flanged	-M : Enhanced
<a href="#">HQA2W120W050V-N07-S</a>	9 - 40	5	24	120	Yes	Non-Flanged	-S : Standard
<a href="#">HQA2W120W120V-007-M</a>	9 - 40	12	10	120	Yes	Flanged	-M : Enhanced
<a href="#">HQA2W120W120V-007-S</a>	9 - 40	12	10	120	Yes	Flanged	-S : Standard
<a href="#">HQA2W120W120V-N07-S</a>	9 - 40	12	10	120	Yes	Non-Flanged	-S : Standard
<a href="#">HQA2W120W150V-007-M</a>	9 - 40	15	8	120	Yes	Flanged	-M : Enhanced
<a href="#">HQA2W120W150V-007-S</a>	9 - 40	15	8	120	Yes	Flanged	-S : Standard
<a href="#">HQA2W120W150V-N07-S</a>	9 - 40	15	8	120	Yes	Non-Flanged	-S : Standard
<a href="#">HQA2W120W240V-007-M</a>	9 - 40	24	5	120	NA	Flanged	-M : Enhanced
<a href="#">HQA2W120W240V-007-S</a>	9 - 40	24	5	120	NA	Flanged	-S : Standard
<a href="#">HQA2W120W240V-N07-M</a>	9 - 40	24	5	120	NA	Non-Flanged	-M : Enhanced
<a href="#">HQA2W120W240V-N07-S</a>	9 - 40	24	5	120	NA	Non-Flanged	-S : Standard
<a href="#">HQA2W120W280V-007-M</a>	9 - 40	28	4.2	120	NA	Flanged	-M : Enhanced
<a href="#">HQA2W120W280V-007-S</a>	9 - 40	28	4.2	120	NA	Flanged	-S : Standard
<a href="#">HQA2W120W280V-N07-M</a>	9 - 40	28	4.2	120	NA	Non-Flanged	-M : Enhanced
<a href="#">HQA2W120W280V-N07-S</a>	9 - 40	28	4.2	120	NA	Non-Flanged	-S : Standard
<a href="#">HQA24120W480V-007-M</a>	18 - 40	48	2.5	120	NA	Flanged	-M : Enhanced
<a href="#">HQA24120W480V-007-S</a>	18 - 40	48	2.5	120	NA	Flanged	-S : Standard
<a href="#">HQA24120W480V-N07-S</a>	18 - 40	48	2.5	120	NA	Non-Flanged	-S : Standard

Consult factory for other valid part number suffixes not shown on the table.

<b>HQA</b>	<b>2W</b>	<b>120W</b>	<b>240V</b>	<b>-</b>	<b>007</b>	<b>-</b>	<b>M</b>
	<b>Input Voltage</b> 2W: 9 - 40 V 24: 18 - 40 V	<b>Output Power</b> 120W: 120Watts	<b>Output Voltage</b> 280V: 28 V 050V: 5 V		<b>Baseplate Construction:</b> 007: Flanged Baseplate N07: Non-Flanged Baseplate		<b>Screening Options:</b> M: Enhanced Screening S: Standard Screening See Screening Option Table below

Screening Options		
Operation	S-Grade (Standard Screening)	M-Grade (Enhanced Screening)
Functional Test	Room and Hot Test	Cold, Room and Hot Test
Burn-In	Yes	Extended, 96 hour
Temperature Cycling	No	10 Cycles
Hi-Pot	2250 Vdc	2250 Vdc
Visual Inspection	Yes	Yes

Related Products		
Type	Type	Description
Isolated DC-DC Converter	<a href="#">HQA85</a>	85W MIL-COTS, Input 9-40V, Isolated Quarter Brick
Isolated DC-DC Converter	<a href="#">GQA</a>	120W Industrial, Input 9-36V, Isolated Quarter Brick
Input Filter	<a href="#">FQA</a>	40V / 20A MIL-COTS Filter for MIL-STD-461
Input Filter	<a href="#">FQB</a>	40V / 20A MIL-COTS Filter for MIL-STD-461; MIL-STD-1275; MIL-STD-704; DO-160G
Evaluation Board	<a href="#">FQX-HQA-EVK-D0</a>	Evaluation board (no modules) that fits 2X HQA or GQA DC-DC converters and FQA/FQB filters

Specifications								
Model		5	12	15	24	28	48	
<b>Input</b>								
Input Voltage Range	Vdc	9 - 40					18 - 40	
Input Transient (t < 1s)	Vdc	50						
Input Current (max)	A	18					10	
Turn-ON Input Voltage	Vdc	9.5					17.0	
Turn-OFF Input Voltage	Vdc	8.5					15.5	
Efficiency	%	90	90	89	87	89	91.5	
Safety Certifications and Markings	-	IEC/UL/CSA/EN 62368-1, 60950-1, CE Mark and UKCA Mark						
<b>Output</b>								
Output Voltage Tolerance	%	±4 (Rated input, Load and Temperature)						
Output Voltage Adjustment Range	Vdc	4.5 - 5.5	10.8 - 13.2	13.5 - 16.5	21.6 - 26.4	25.2 - 30.8	45.6 - 52.8	
Line Regulation	%	0.05						
Load Regulation	%	0.03						
External Load Capacitance	µF	22 - 2400	0 - 1800	0 - 1500	0 - 1000	0 - 1000	0 - 1000	
Ripple & Noise	mVpp	40	40	100	100	100	125	
Switching Frequency	kHz	270						
Overcurrent Protection Threshold (typ)	A	37	14.5	12	6.2	5.2	4	
Over Voltage protection (typ)	Vdc	6.5	15	18	32	35	54	
Over Temperature Protection	-	Shutdown - Autorecovery						
<b>Environmental</b>								
Operating Temperature (Tc)	°C	-40 to 115 (-S : Standard Screening) -55 to 115 (-M : Enhanced Screening)						
Storage Temperature	°C	-65 to 125						
Humidity (non condensing)	%RH	10 - 95						
Cooling	-	Conduction Cooling						
Isolation Voltage	Vdc	2250 (Input to Output / Input to Baseplate / Output to Baseplate)						
Isolation Resistance	MΩ	> 10						
Shock	-	MIL-STD-202G, Method 213B, Table 213-1, Test Condition I						
Vibration	-	MIL-STD-202G, Method 201A						
Altitude	ft	70,000; MIL-STD-883F Method 1001 / MIL-STD-810G Method 500.5 Procedure I, II, III						
Qualification Methods		MIL-STD-883F; MIL-STD-202G and MIL-STD-810G						
<b>Other</b>								
Weight (max)	g	100 (Flanged Baseplate)						
Size (LxWxH)	mm	Flanged Baseplate: 60.6 x 55.9 x 12.7 Non-Flanged Baseplate: 60.6 x 39 x 12.7						
Size (LxWxH)	Inches	Flanged Baseplate: 2.39 x 2.2 x 0.5 Non-Flanged Baseplate: 2.39 x 1.54 x 0.5						
MTBF - Telcordia SR-332	-	> 4 Mhrs; 100% Load; Ta = 40°C						
Warranty	yrs	3						

Notes:  
See website for detailed product [specifications](#).

## PIN Assignment

PIN	Function	PIN	Function
1	Vin (+)	5	Sense (-), select models*
2	On/Off	6	Trim
3	Vin (-)	7	Sense (+), select models*
4	Vo (-)	8	Vo (+)

Pin base material is tellurium copper with tin over nickel plating.

\* Sense pins are available on 5, 12 and 15 V models.

## HQA DC-DC Modules with FQB Active Input Filter Module

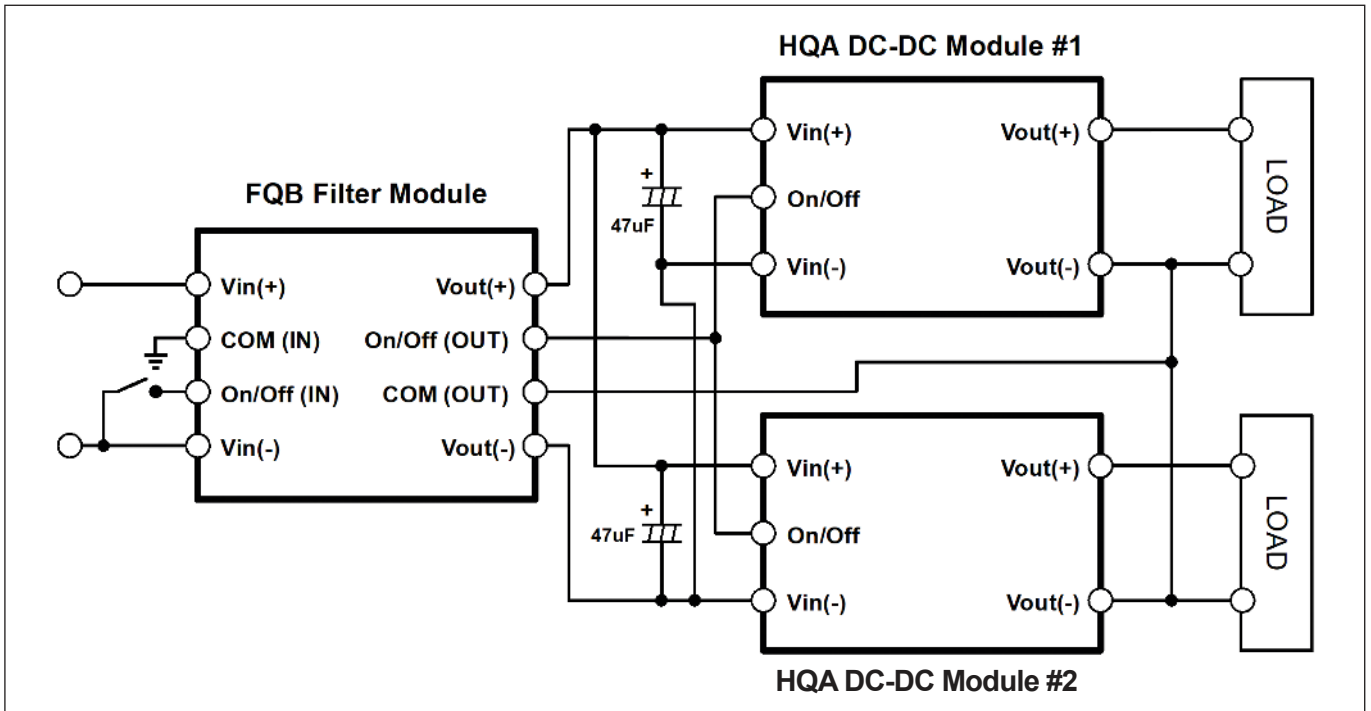

## HQA DC-DC Modules with FQA Passive Input Filter Module

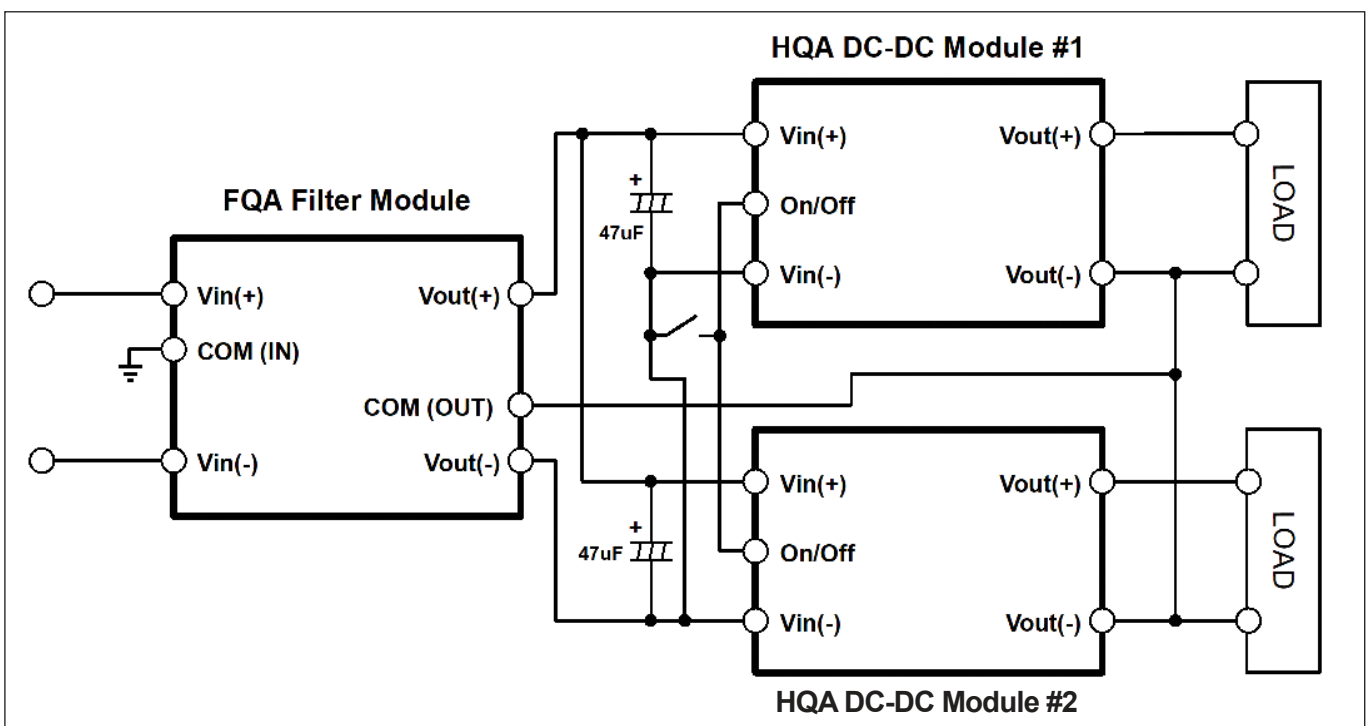

**Mechanical Specification: (Flanged Baseplate)**

Dimensions are in mm [in]. Unless otherwise specified tolerances are:  
 x.x [x.xx] ± 0.5 [0.02], x.xx [x.xxx] ± 0.25 [0.010]

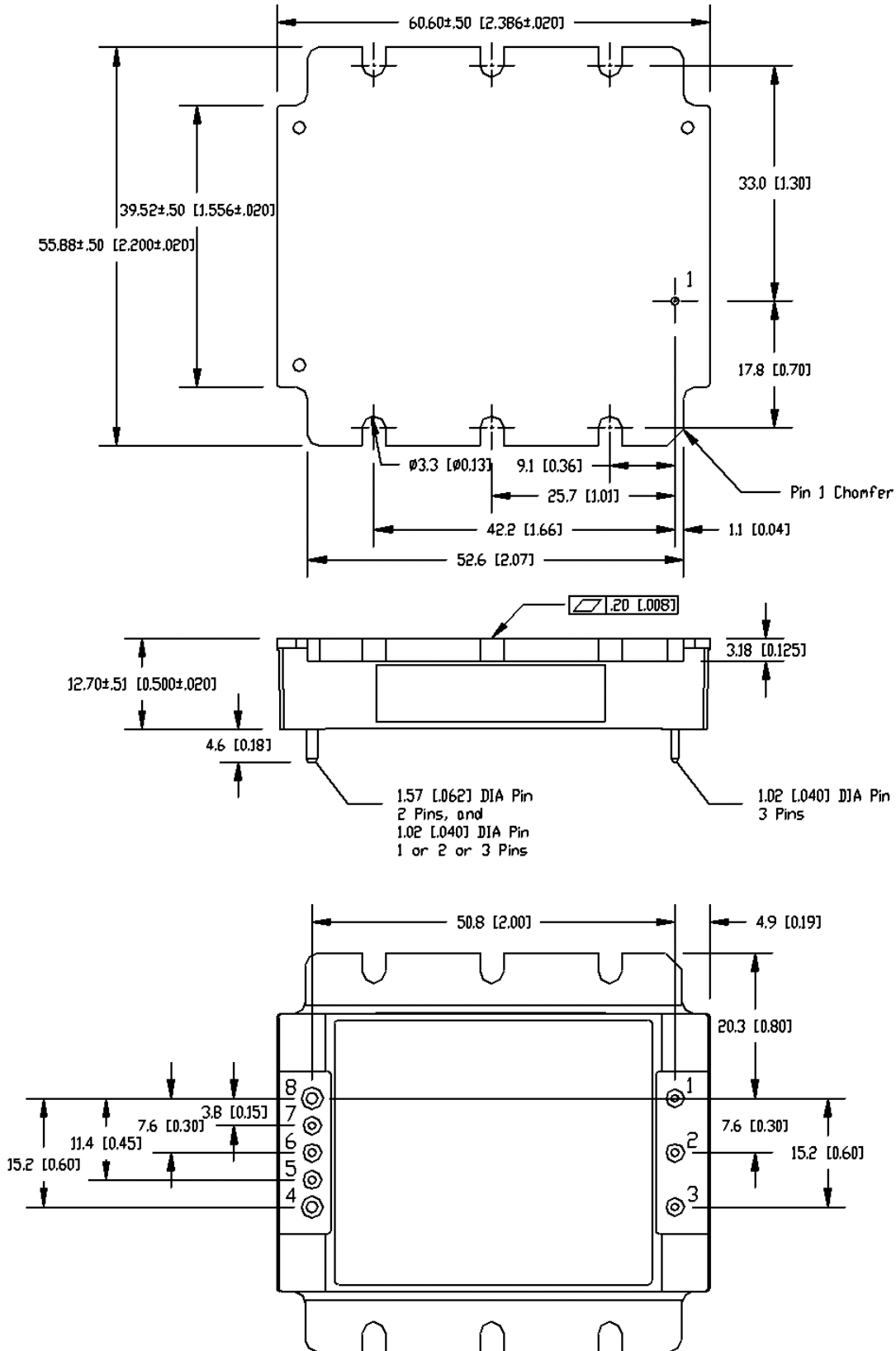

**Mechanical Specification: (Non-Flanged Baseplate)**

Dimensions are in mm [in]. Unless otherwise specified tolerances are:  
 x.x [x.xx] ± 0.5 [0.02], x.xx [x.xxx] ± 0.25 [0.010]  
 To avoid damaging components, do not exceed 3.0mm [0.12"] depth for M3 screws

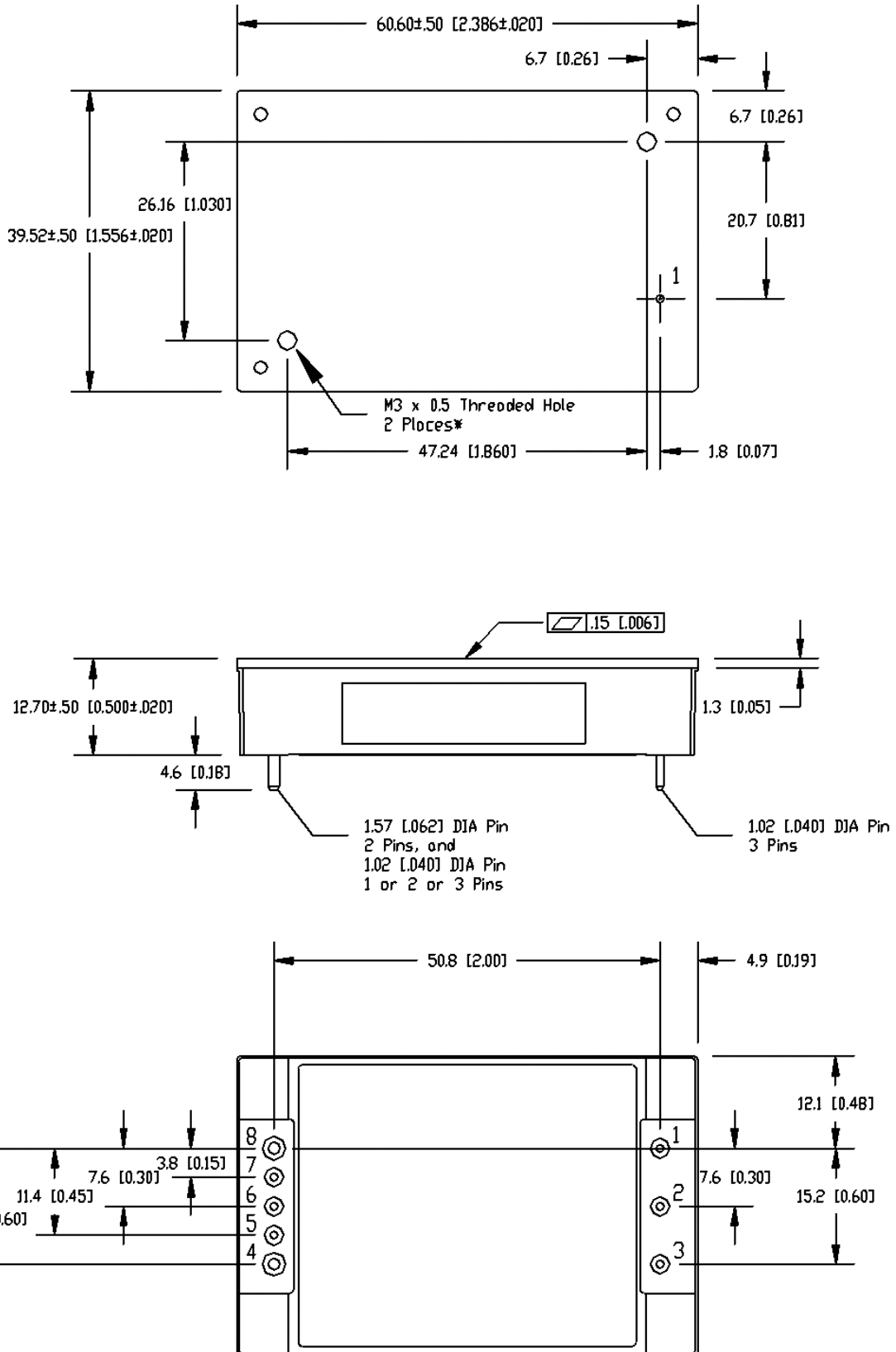

**Recommended Hole Pattern**

(Pin Side Down – Flanged Baseplate)

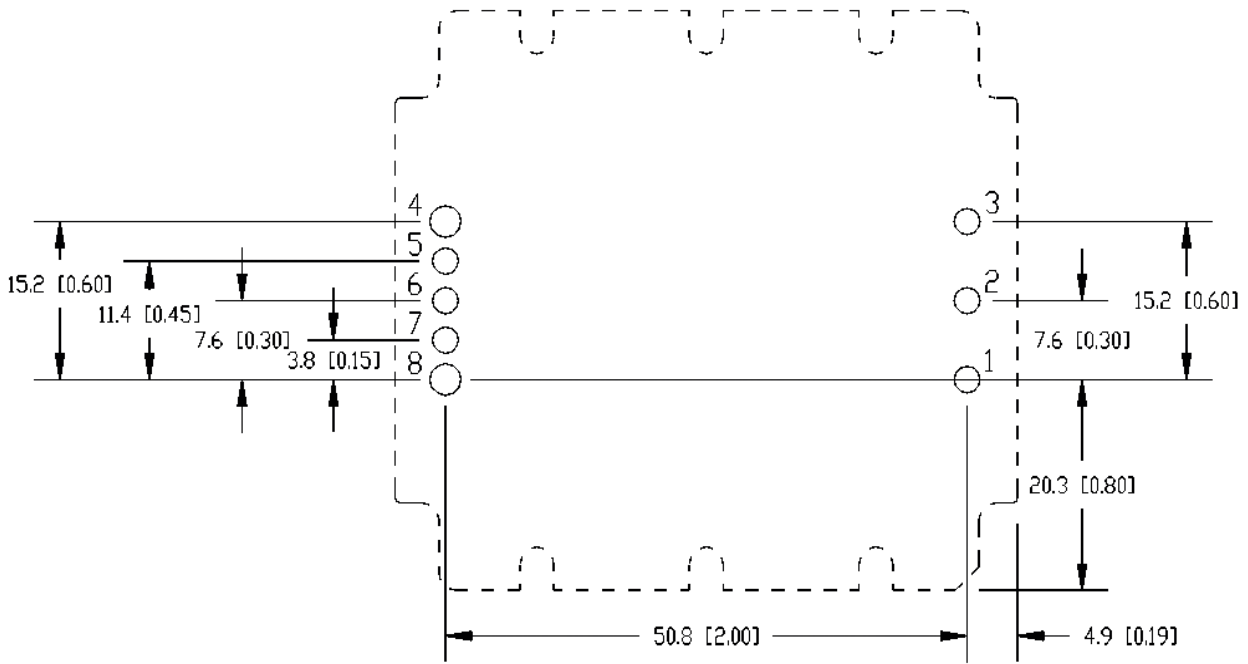

**Recommended Hole Pattern**

(Pin Side Down – Non-Flanged Baseplate)

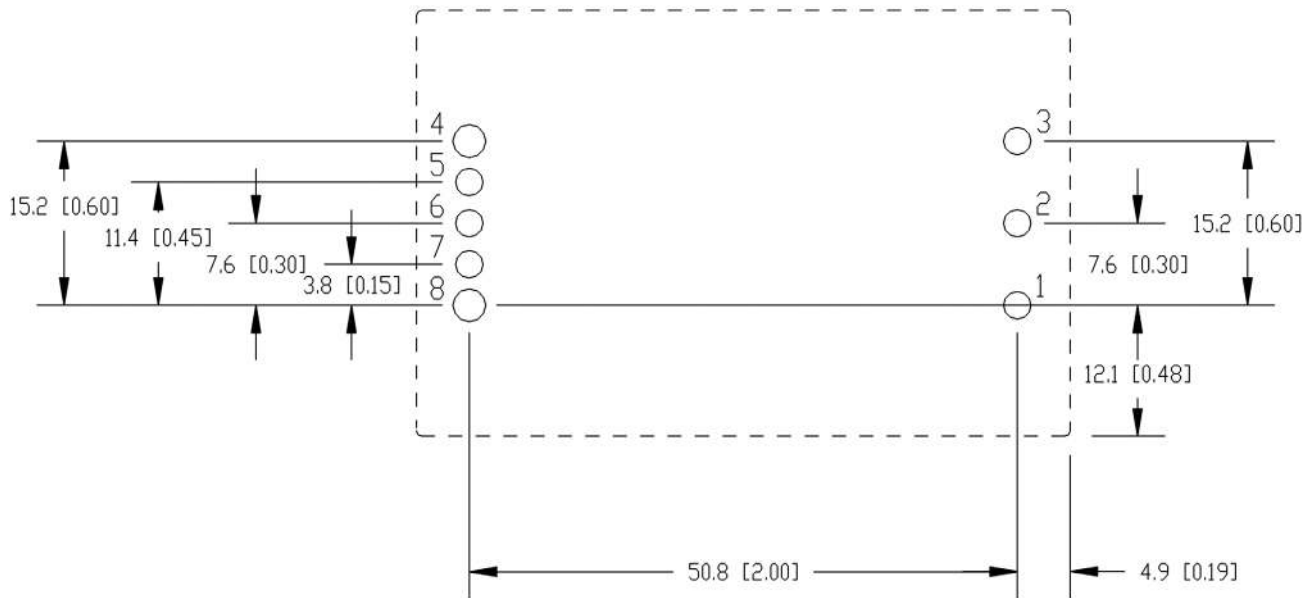



### TDK-Lambda France SAS

Tel: +33 1 60 12 71 65  
tlf.fr-powersolutions@tdk.com  
www.emea.lambda.tdk.com/fr



### Italy Sales Office

Tel: +39 02 61 29 38 63  
tlf.it-powersolutions@tdk.com  
www.emea.lambda.tdk.com/it



### Netherlands

tlf.nl-powersolutions@tdk.com  
www.emea.lambda.tdk.com/nl



### TDK-Lambda Germany GmbH

Tel: +49 7841 666 0  
tlg.powersolutions@tdk.com  
www.emea.lambda.tdk.com/de



### Austria Sales Office

Tel: +43 2256 655 84  
tlg.at-powersolutions@tdk.com  
www.emea.lambda.tdk.com/at



### Switzerland Sales Office

Tel: +41 44 850 53 53  
tlg.ch-powersolutions@tdk.com  
www.emea.lambda.tdk.com/ch



### Nordic Sales Office

Tel: +45 8853 8086  
tlg.dk-powersolutions@tdk.com  
www.emea.lambda.tdk.com/dk



### TDK-Lambda UK Ltd.

Tel: +44 (0) 12 71 85 66 66  
tlu.powersolutions@tdk.com  
www.emea.lambda.tdk.com/uk



### TDK-Lambda Ltd.

Tel: +9 723 902 4333  
tli.powersolutions@tdk.com  
www.emea.lambda.tdk.com/il-en



### TDK-Lambda Americas

Tel: +1 800-LAMBDA-4 or 1-800-526-2324  
tla.powersolutions@tdk.com  
www.us.lambda.tdk.com



### TDK Electronics do Brasil Ltda

Tel: +55 11 3289-9599  
sales.br@tdk-electronics.tdk.com  
www.tdk-electronics.tdk.com/en



### TDK-Lambda Corporation

Tel: +81-3-6778-1113  
www.jp.lambda.tdk.com



### TDK-Lambda (China) Electronics Co. Ltd.

Tel: +86 21 6485-0777  
tlc.powersolutions@tdk.com  
www.lambda.tdk.com.cn



### TDK-Lambda Singapore Pte Ltd.

Tel: +65 6251 7211  
tfs.marketing@tdk.com  
www.sg.lambda.tdk.com



### TDK India Private Limited, Power Supply Division

Tel: +91 80 4039-0660  
mathew.philip@tdk.com  
www.sg.lambda.tdk.com

