

ARM[®] Cortex[®]-M
32-bit Microcontroller

NuMaker-PFM-M487
User Manual
NuMicro[®] M480 Series

The information described in this document is the exclusive intellectual property of Nuvoton Technology Corporation and shall not be reproduced without permission from Nuvoton.

Nuvoton is providing this document only for reference purposes of NuMicro microcontroller based system design. Nuvoton assumes no responsibility for errors or omissions.

All data and specifications are subject to change without notice.

For additional information or questions, please contact: Nuvoton Technology Corporation.

www.nuvoton.com

Table of Contents

1 Overview 6

 1.1 Introduction to ARM® mbed™ 6

 1.2 Introduction to NuMaker-PFM-M487 Board 6

 1.3 M487 Series MCU Features 7

 1.4 NuMaker-PFM-M487 Board Features 8

2 NuMaker-PFM-M487 Board Overview 9

 2.1 Front View 9

 2.2 Rear View 10

 2.3 Arduino UNO Compatible Interface 11

 2.4 Pin Assignment for Extended Connectors 13

 2.5 System Configuration 18

 2.5.1 5V Power Source 18

 2.5.2 3.3V Power Source 18

 2.5.3 USB Connectors 19

 2.5.4 Ethernet Connectors 19

 2.5.5 Arduino UNO Compatible Interface Connectors 19

 2.5.6 Extended Connectors 19

 2.5.7 Phone Jack 19

 2.5.8 MicroSD Card Slot 19

 2.5.9 Push-Buttons 19

 2.5.10 LEDs 19

 2.5.11 Heartbeat Sensor Pads 19

 2.5.12 Power Connectors 19

 2.6 Audio 20

 2.7 Heartbeat Sensor 21

 2.8 Nu-Link-Me 23

 2.9 PCB Placement 24

3 NuMaker-PFM-M487 Schematics 25

 3.1 Nu-Link-Me 25

 3.2 M487JIDAE 26

 3.3 Power Supply 27

 3.4 Arduino UNO Compatible Interface 28

 3.5 Reset 29

3.6 Crystal29

3.7 LEDs30

3.8 Push-Buttons30

3.9 MicroSD Card31

3.10 USB 2.0 HS OTG and USB 1.1 FS OTG32

3.11 Ethernet33

3.12 24-bit Stereo Audio Codec34

3.13 Heartbeat Sensor and SPI Flash.....35

4 REVISION HISTORY 36

List of Figures

Figure 1-1 NuMaker-PFM-M487 Board 6

Figure 2-1 Front View of NuMaker-PFM-M487 Board 9

Figure 2-2 Rear View of NuMaker-PFM-M487 Board 10

Figure 2-3 Arduino UNO Compatible Interface 11

Figure 2-4 M487JIDAE Extended Connectors 13

Figure 2-5 3.5mm Phone Jack Diagram 20

Figure 2-6 Heartbeat Sensor Block Diagram 21

Figure 2-7 Front Placement 24

Figure 2-8 Rear Placement 24

Figure 3-1 Nu-Link-Me Circuit 25

Figure 3-2 M487JI8AE Pin Assignment 26

Figure 3-3 Power Circuit and Configurations 27

Figure 3-4 Arduino UNO Compatible Interface 28

Figure 3-5 Reset Circuit 29

Figure 3-6 External Crystal Circuit 29

Figure 3-7 Power LED and IO LED Circuit 30

Figure 3-8 Push-Buttons Circuit 30

Figure 3-9 MicroSD Card Circuit 31

Figure 3-10 USB HS OTG and FS OTG Circuits 32

Figure 3-11 Ethernet Circuit 33

Figure 3-12 Audio Codec Circuit 34

Figure 3-13 Heartbeat Sensor and SPI Flash Circuits 35

List of Tables

Table 2-1 Arduino UNO Interface Mapping with M487JIDAE GPIO 12

Table 2-2 Extended Connector JP6 Interface with M487JIDAE GPIO 14

Table 2-3 Extended Connector JP8 Interface with M487JIDAE GPIO 15

Table 2-4 Extended Connector JP7 Interface with M487JIDAE GPIO 16

Table 2-5 Extended Connector JP9 Interface with M487JIDAE GPIO 17

Table 2-6 NAU88L25 Mapping with M487JIDAE 20

Table 2-7 Pin Usage of Heartbeat Sensor 22

Table 2-8 Optional Function of Nu-Link-Me 23

1 OVERVIEW

This user manual is aimed to give users a fast introduction to the use of ARM® mbed™ and NuMaker-PFM-M487 board.

1.1 Introduction to ARM® mbed™

The ARM® mbed™ IoT Device Platform provides the operating system, cloud services, tools and developer ecosystem to make the creation and deployment of commercial, standards-based IoT solutions possible.

The ARM® mbed™ allows IoT devices to collaborate and communicate with each other on the basis of transparency - otherwise each of the devices will not be able to talk to each other or to the cloud. For more detailed information about ARM® mbed™, user can visit the related ARM® mbed™ websites as the follows:

ARM® mbed™ homepage: www.mbed.com/en/

Software homepage: docs.mbed.com/docs/mbed-os-handbook/en/

Official C/C++ SDK: developer.mbed.org/users/mbed_official/code/mbed/

1.2 Introduction to NuMaker-PFM-M487 Board

The NuMaker-PFM-M487 is a development board based on an ARM® Cortex®-M4 microcontroller (MCU) – M480 series which has very rich peripherals.

This board is provided by Nuvoton and created specially to support the ARM® mbed™ IoT Device Platform, and let user easily to develop the IoT application program on this board. The NuMaker-PFM-M487 also provides user many useful and powerful learning materials for how to develop and verify the application programs through the peripherals and interfaces on MCU and this board.

Furthermore, this board also provides an Arduino UNO compatible interface for user to develop the specific function with any of Arduino modules or kits. Regarding to the Arduino, user can link directly to the Wikipedia website: en.wikipedia.org/wiki/Arduino to get more detailed introductions.

The NuMaker-PFM-M487 board consists of M487 Platform and Nu-Link-Me ICE Bridge. Figure 1-1 shows the NuMaker-PFM-M487 board.

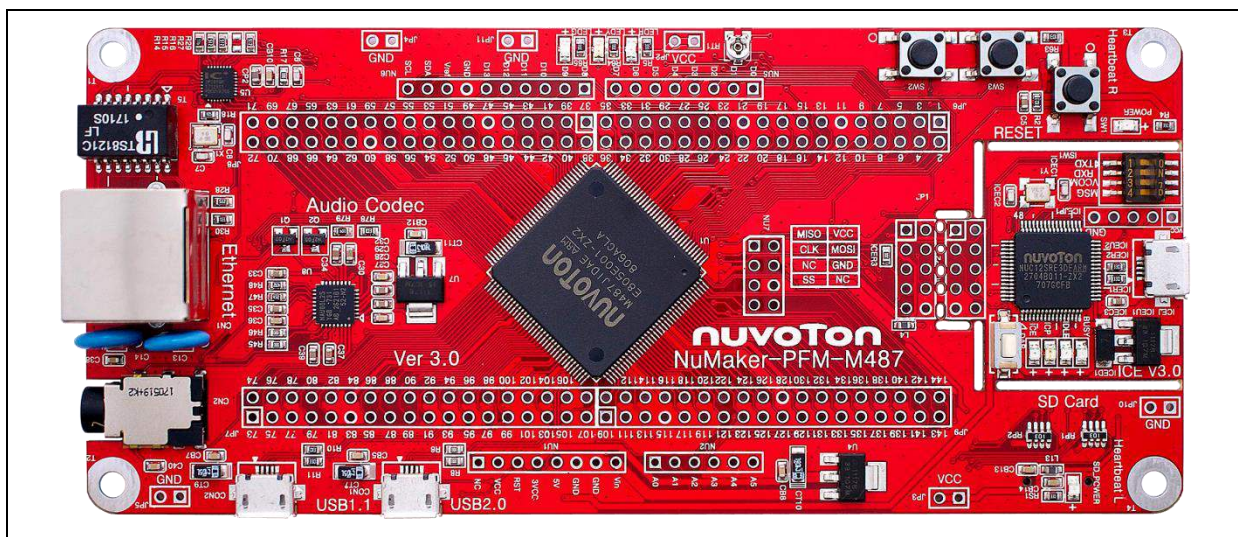

Figure 1-1 NuMaker-PFM-M487 Board

The left portion of this board is the M487 Platform that includes the target chip M487 MCU which embedded ARM[®] Cortex[®]-M4 core with DSP extensions and a Floating Point Unit (FPU) and the other related on-board application parts and connectors.

The right portion of this board is a Nu-Link-Me ICE Bridge based on the SWD (Serial Wire Debug) interface connected with the target chip, allowing user to program the application code to the flash of target chip through the USB port from PC Host.

For more information on the NuMaker-PFM-M487 board for the ARM[®] mbed[™] Device Platform, please visit the ARM[®] mbed[™] hardware board website:

<https://developer.mbed.org/platforms/NUMAKER-PFM-M487/>

1.3 M487 Series MCU Features

- M487JIDAE in LQFP144 package
- ARM[®] Cortex[®]-M4 core running up to 192 MHz with DSP extensions and FPU (Floating Point Unit)
- Built-in LDO for wide operating voltage ranged from 1.8 V to 3.63 V
- 512 Kbytes Flash
- 160 Kbytes SRAM
- External Bus Interface (EBI)
- GPIO
- Peripheral DMA (PDMA)
- Timer
- PWM and BPWM
- Quadrature Encoder Interface (QEI)
- WDT and WWDT
- RTC
- UART
- Smart Card (ISO-7816-3) Host Interface
- I²C
- SPI
- SPIM
- I²S
- Universal Serial Control Interface (USCI)
- USB 2.0 High-Speed OTG / Host / Device
- USB 1.1 Full-Speed OTG / Host / Device
- CAN 2.0
- Ethernet MAC
- SD Host
- Cryptographic Accelerator
- CRC

- ADC
- DAC
- Comparator

1.4 NuMaker-PFM-M487 Board Features

- On board Nu-Link-Me ICE Bridge (Mass storage as USB Disk drive) for drag and drop programming
- Arduino UNO compatible interface
- M487 extended interface connectors
- Audio codec (NAU88L25) with Microphone In and Headphone Out
- Ethernet for network application
- USB 2.0 High-Speed OTG / Host / Device
- USB 1.1 Full-Speed OTG / Host / Device
- External SPI Flash which can be regarded as ROM module
- MicroSD Card slot for T-Flash
- Three push-buttons: one is for reset and the other two are for user-defined
- Four LEDs: one is for power indication and the other three are for user-defined

2 NUMAKER-PFM-M487 BOARD OVERVIEW

2.1 Front View

Figure 2-1 shows the main components and connectors from the front side of NuMaker-PFM-M487 board.

The following lists components and connectors from the front view:

- Target Chip: M487JIDAE (U1)
- Nu-Link-Me ICE Bridge: ICE Controller NUC12SRE3DE (ICEU2), USB connector (ICEJ) to PC Host
- Audio: Audio Codec NAU88L25 (U2), Headphone (CN2)
- Arduino UNO compatible interface connectors (NU1, NU2, NU5 and NU6)
- M487 extended interface connectors (JP6, JP7, JP8 and JP9)
- USB: USB 2.0 High-Speed OTG connector (CON1) and USB 1.1 OTG connector (CON2)
- Ethernet Transceivers: IP101GR (U5)
- Push-buttons (SW2, SW3)
- LEDs (I/O1, I/O2 and I/O3)

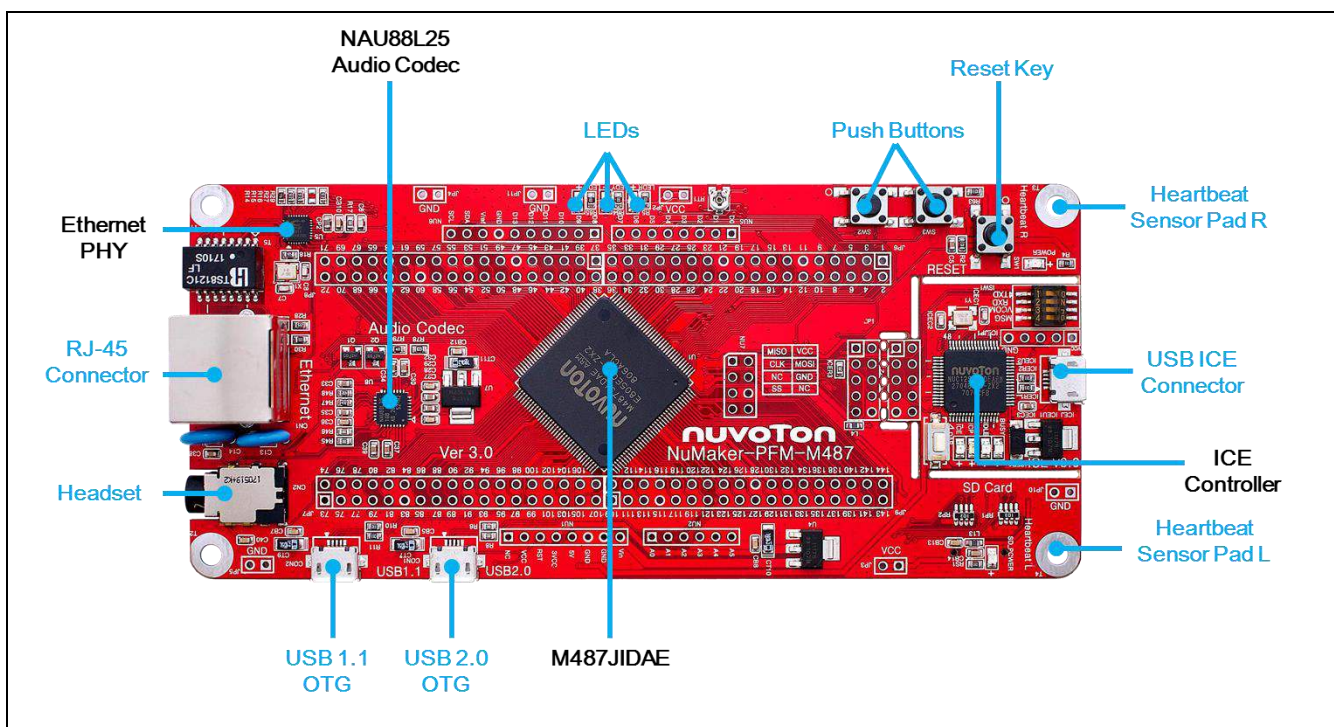

Figure 2-1 Front View of NuMaker-PFM-M487 Board

2.2 Rear View

Figure 2-2 shows the main components and connectors from the rear side of NuMaker-PFM-M487 board.

The following lists components and connectors from the rear view:

- MicroSD Card Slot: T-Flash slot (U9)
- SPI Flash: Winbond W25Q20 (U6)

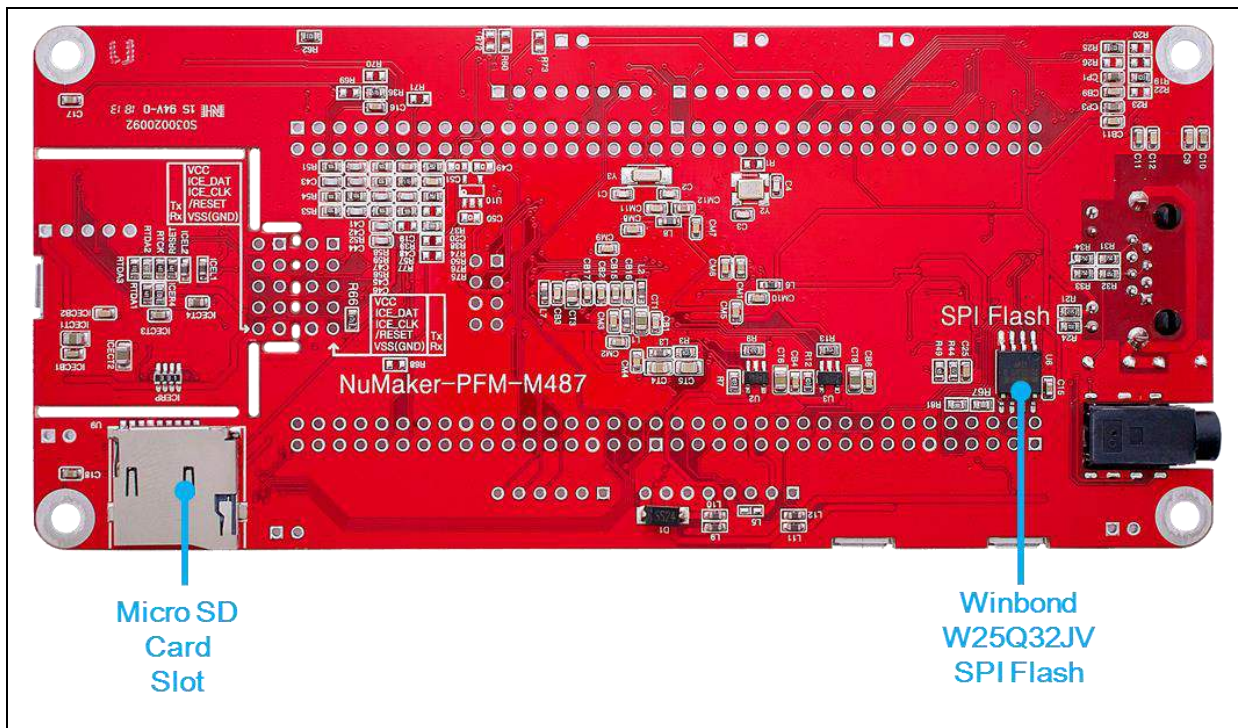

Figure 2-2 Rear View of NuMaker-PFM-M487 Board

2.3 Arduino UNO Compatible Interface

Figure 2-3 shows the Arduino UNO compatible interface.

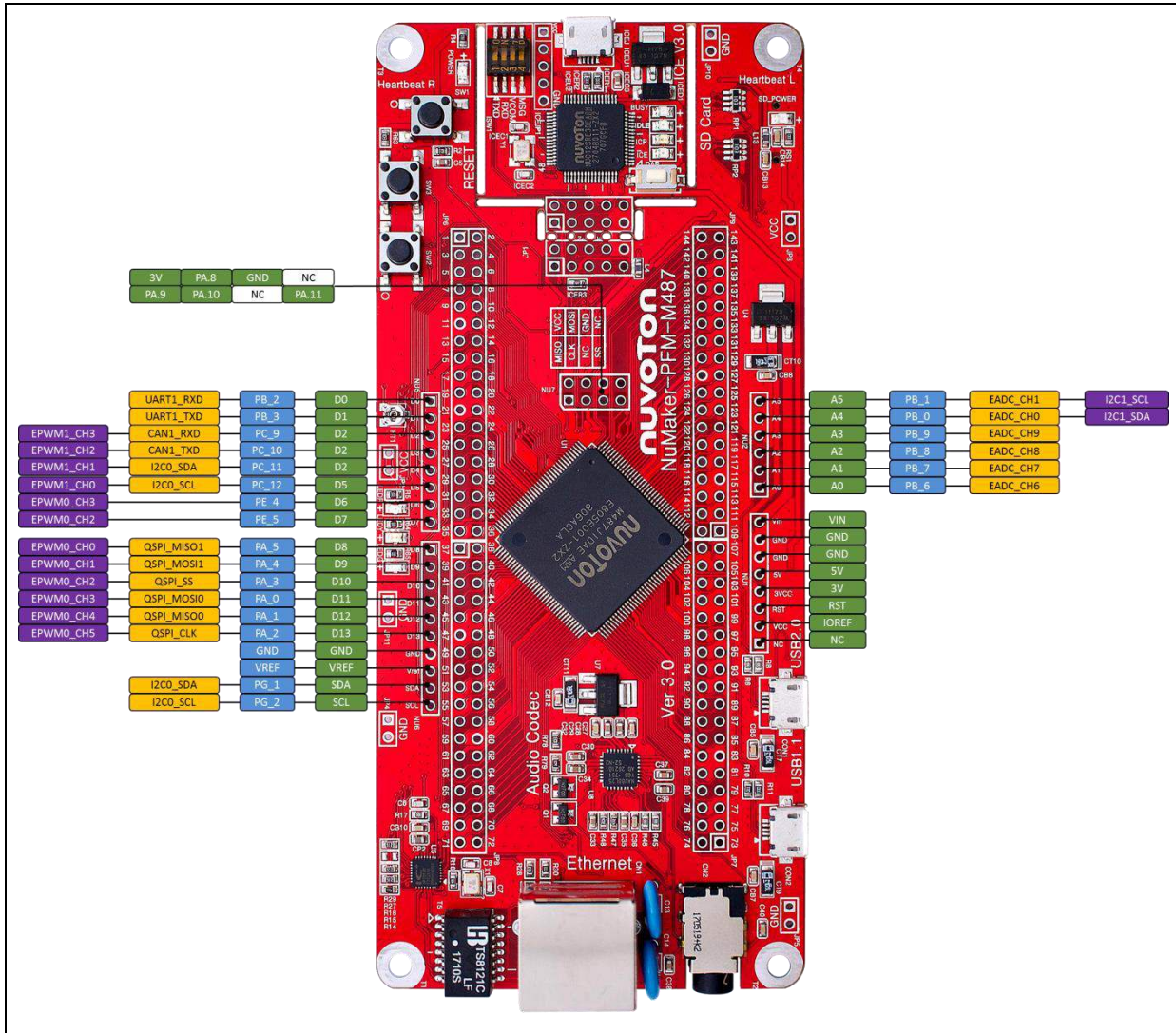

Figure 2-3 Arduino UNO Compatible Interface

Table 2-1 Arduino UNO Interface Mapping with M487JIDAE GPIO

Header		NuMaker-PFM-M487		Header		NuMaker-PFM-M487	
		Compatible to Arduino UNO	GPIO Pin of M487			Compatible to Arduino UNO	GPIO Pin of M487
NU1	NU1.1	NC	-	NU6.10	SCL	PG.0	
	NU1.2	IOREF		NU6.9	SDA	PG.1	
	NU1.3	RESET	RESET	NU6.8	VREF	-	
	NU1.4	3VCC	-	NU6.7	GND		
	NU1.5	5VCC		NU6.6	D13	PA.2	
	NU1.6	GND		NU6.5	D12	PA.1	
	NU1.7	GND		NU6.4	D11	PA.0	
	NU1.8	VIN		NU6.3	D10	PA.3	
NU2	NU2.1	A0		PB.6	NU6.2	D9	PA.4
	NU2.2	A1	PB.7	NU6.1	D8	PA.5	
	NU2.3	A2	PB.8	NU5.8	D7	PE.5	
	NU2.4	A3	PB.9	NU5.7	D6	PE.4	
	NU2.5	A4	PB.0	NU5.6	D5	PC.12	
	NU2.6	A5	PB.1	NU5.5	D4	PC.11	
NU5				NU5.4	D3	PC.10	
				NU5.3	D2	PC.9	
				NU5.2	D1	PB.3	
				NU5.1	D0	PB.2	

Header		NuMaker-PFM-M487		Header		NuMaker-PFM-M487	
		Compatible to Arduino UNO	GPIO Pin of M487			Compatible to Arduino UNO	GPIO Pin of M487
NU7	NU7.1	VCC	-	NU7.2	MISO	PA.9	
	NU7.3	CLK	PA.10	NU7.4	MOSI	PA.8	
	NU7.5	NC	-	NU7.6	GND	-	
	NU7.7	SS	PA.11	NU7.8	NC	-	

2.4 Pin Assignment for Extended Connectors

The NuMaker-PFM-M487 provides the M487JIDAE target chip onboard and extended connectors (JP6, JP7, JP8 and JP9) for LQFP144-pin. The Figure 2-4 shows the M487JIDAE extended connectors.

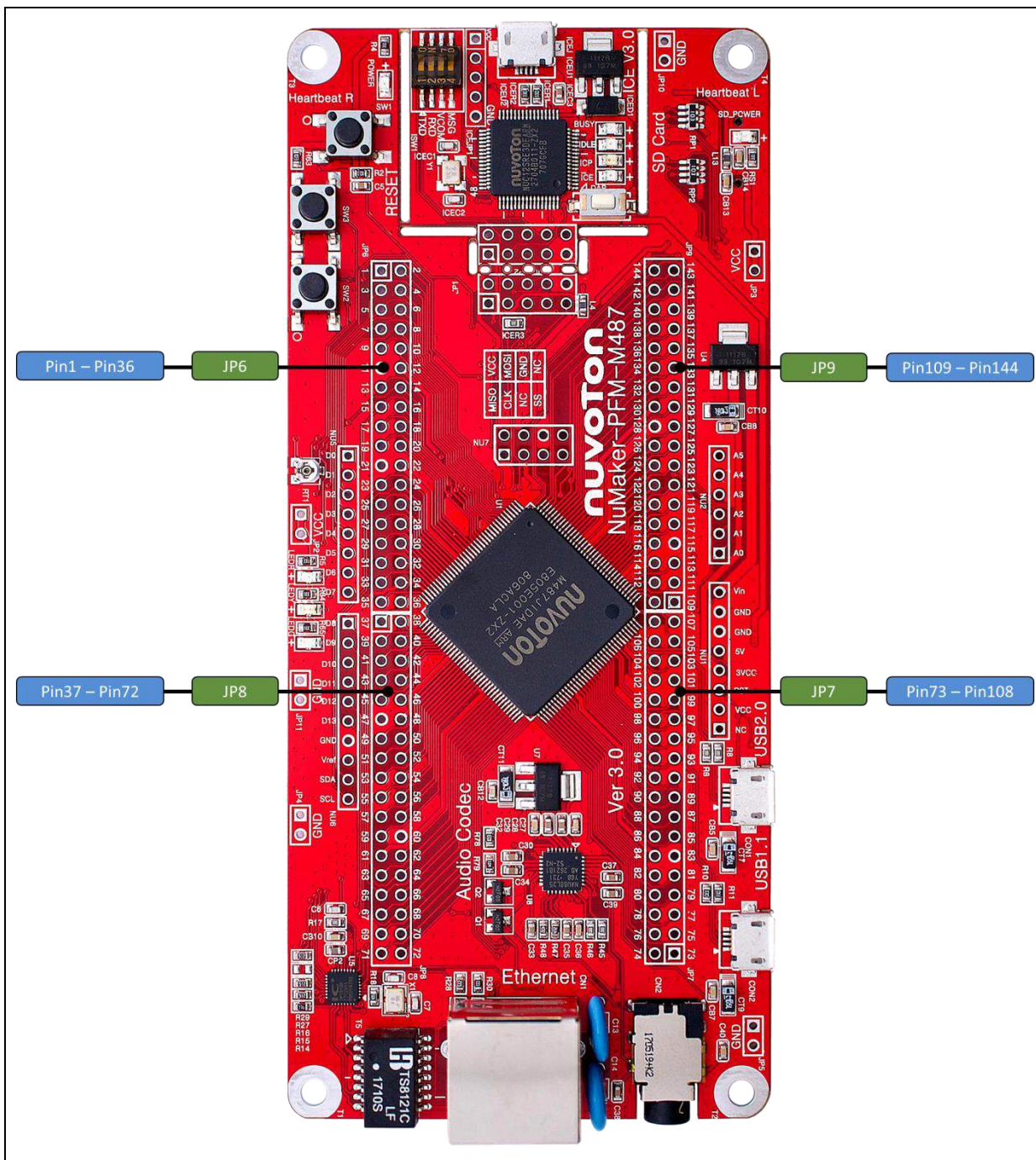

Figure 2-4 M487JIDAE Extended Connectors

Table 2-2 Extended Connector JP6 Interface with M487JIDAE GPIO

Header		M487JIDAE		Header		M487JIDAE	
		Pin No.	Function			Pin No	Function
JP6	JP6.1	1	SD0_DAT3	JP6	JP6.2	2	SD0_DAT2
	JP6.3	3	PB.3		JP6.4	4	OPA0_O
	JP6.5	5	PC.12		JP6.6	6	PC.11
	JP6.7	7	PC.10		JP6.8	8	PC.9
	JP6.9	9	OPA0_N		JP6.10	10	OPA0_P
	JP6.11	11	GND		JP6.12	12	3VCC
	JP6.13	13	PA.11		JP6.14	14	OPA1_O
	JP6.15	15	OPA1_N		JP6.16	16	OPA1_P
	JP6.17	17	JKDET		JP6.18	18	OPA2_O
	JP6.19	19	OPA2_N		JP6.20	20	OPA2_P
	JP6.21	21	GND		JP6.22	22	3VCC
	JP6.23	23	PG.0		JP6.24	24	PG.1
	JP6.25	25	PG.2		JP6.26	26	PG.3
	JP6.27	27	PG.4		JP6.28	28	SW3
	JP6.29	29	I2S0_BCLK		JP6.30	30	I2S0_MCLK
	JP6.31	31	I2S0_DI		JP6.32	32	I2S0_DO
	JP6.33	33	I2S0_LRCK		JP6.34	34	3VCC
JP6.35	35	XT32_IN	JP6.36	36	XT32_OUT		

Table 2-3 Extended Connector JP8 Interface with M487JIDAE GPIO

Header		M487JIDAE		Header		M487JIDAE	
		Pin No.	Function			Pin No	Function
JP8	JP8.1	37	LED_R	JP8	JP8.2	38	LED_Y
	JP8.3	39	LED_G		JP8.4	40	PH.3
	JP8.5	41	PH.4		JP8.6	42	PH.5
	JP8.7	43	PH.6		JP8.8	44	PH.7
	JP8.9	45	XT1_IN		JP8.10	46	XT1_OUT
	JP8.11	47	GND		JP8.12	48	3VCC
	JP8.13	49	EMAC_MDC		JP8.14	50	EMAC_MDIO
	JP8.15	51	EMAC_TXD0		JP8.16	52	EMAC_TXD1
	JP8.17	53	EMAC_TXEN		JP8.18	54	PE.13
	JP8.19	55	EMAC_REFCLK		JP8.20	56	EMAC_RXD0
	JP8.21	57	EMCAC_RXD1		JP8.22	58	EMAC_RXDV
	JP8.23	59	EMAC_RXERR		JP8.24	60	GND
	JP8.25	61	3VCC		JP8.26	62	LDO_CAP
	JP8.27	63	PA.5		JP8.28	64	PA.4
	JP8.29	65	PA.3		JP8.30	66	PA.2
	JP8.31	67	PA.1		JP8.32	68	PA.0
	JP8.33	69	VDDIO		JP8.34	70	PE.14
JP8.35	71	PE.15	JP8.36	72	nRESET		

Table 2-4 Extended Connector JP7 Interface with M487JIDAE GPIO

Header		M487JIDAE		Header		M487JIDAE	
		Pin No.	Function			Pin No	Function
JP7	JP7.1	73	ICEDAT	JP7	JP7.2	74	ICECLK
	JP7.3	75	PD.9		JP7.4	76	PD.8
	JP7.5	77	SPIM_D2		JP7.6	78	SPIM_D3
	JP7.7	79	SPIM_SS		JP7.8	80	SPIM_CLK
	JP7.9	81	SPIM_MISO		JP7.10	82	SPIM_MOSI
	JP7.11	83	GND		JP7.12	84	3VCC
	JP7.13	85	PG.9		JP7.14	86	PG.10
	JP7.15	87	PG.11		JP7.16	88	PG.12
	JP7.17	89	PG.13		JP7.18	90	PG.14
	JP7.19	91	SW2		JP7.20	92	PD.3
	JP7.21	93	PD.2		JP7.22	94	I2C2_SCL
	JP7.23	95	I2C2_SDA		JP7.24	96	SD0_nCD
	JP7.25	97	USB_VBUS		JP7.26	98	USB_D-
	JP7.27	99	USB_D+		JP7.28	100	USB_ID
	JP7.29	101	HSUSB_VRES		JP7.30	102	HSUSB_VDD33
	JP7.31	103	HSUSB_VBUS		JP7.32	104	HSUSB_D-
	JP7.33	105	HSUSB_VSS		JP7.34	106	HSUSB_D+
JP7.35	107	HSUSB_VDD12_CAP	JP7.36	108	HSUSB_ID		

Table 2-5 Extended Connector JP9 Interface with M487JIDAE GPIO

Header		M487JIDAE		Header		M487JIDAE	
		Pin No.	Pin Name			Pin No	Pin Name
JP9	JP9.1	109	SD0_CMD	JP9	JP9.2	110	SD0_CLK
	JP9.3	111	PE.5		JP9.4	112	PE.4
	JP9.5	113	SD0_DAT1		JP9.6	114	SD0_DAT0
	JP9.7	115	GND		JP9.8	116	3VCC
	JP9.9	117	PE.1		JP9.10	118	PE.0
	JP9.11	119	PH.8		JP9.12	120	PH.9
	JP9.13	121	PH.10		JP9.14	122	PH.11
	JP9.15	123	PD.14		JP9.16	124	PG.5
	JP9.17	125	PG.6		JP9.18	126	PG.7
	JP9.19	127	PG.8		JP9.20	128	GND
	JP9.21	129	LDO_CAP		JP9.22	130	3VCC
	JP9.23	131	USB_VBUS_ST		JP9.24	132	USB_VBUS_EN
	JP9.25	133	EADC0_CH14		JP9.26	134	TXD
	JP9.27	135	RXD		JP9.28	136	AVDD
	JP9.29	137	VREF		JP9.30	138	ADAVSS
	JP9.31	139	HSUSB_VBUS_ST		JP9.32	140	HSUSB_VBUS_EN
	JP9.33	141	PB.9		JP9.34	142	PB.8
JP9.35	143	PB.7	JP9.36	144	PB.6		

2.5 System Configuration

2.5.1 5V Power Source

- **ICEJ:** USB connector in Nu-Link-Me to program code and supplies 5V power from PC Host.
- **CON1:** USB 2.0 High-Speed OTG connector on NuMaker-PFM-M487 board to supply 5V power from PC Host when this USB is a device that be decided by the ID pin of OTG cable and this ID pin is low.
- **CON2:** USB 1.1 OTG connector on NuMaker-PFM-M487 board to supply 5V power from PC Host when this USB is a device that be decided by the ID pin of OTG cable and this ID pin is low.
- **NU1 pin5:** VDD5V voltage connector on NuMaker-PFM-M487 board to supply 5V power from external power source.

Power Source	Connector	Comment
ICE_USB_VBUS	ICEJ	ICEJ supplies the 5V power from PC Host. Note: L2 should be shorted 0ohm
HSUSB_VBUS	CON1	CON1 supplies the 5V power from PC Host. Note: L11 should be shorted 0ohm.
USB_VBUS	CON2	CON2 supplies the 5V power from PC Host. Note: L12 should be shorted 0ohm.
External 5V Source	NU1 pin5	NU1 pin5 supplies the 5V power from external power source. Note: L10 should be shorted 0ohm.

2.5.2 3.3V Power Source

- **ICEU1:** The voltage regular converts the 5V source to 3.3V and supplies it to NuMaker-PFM-M487 board.
- **U4:** The voltage regular converts the 5V source to 3.3V and supplies it to NuMaker-PFM-M487 board.

Voltage Regular	5V Source	Comment
ICEU1	ICE_USB_VBUS	ICEU1 convert ICE_USB_VBUS to 3.3V and supplies it to M487 platform board. Note: L4 should be shorted 0ohm
U4	HSUSB_VBUS	U4 convert HSUSB_VBUS to 3.3V and supplies it to M487 platform board. Note: L5 should be shorted 0ohm.
U4	USB_VBUS	U4 convert USB_VBUS to 3.3V and supplies it to M487 platform board. Note: L5 should be shorted 0ohm.

2.5.3 USB Connectors

- **ICEJ:** USB connector (ICE) in Nu-Link-Me that connects to a PC's USB Host port to program code and supply power.
- **CON1:** USB 2.0 High-Speed connector (OTG) on NuMaker-PFM-M487 board for USB OTG application use.
- **CON2:** USB 1.1 connector (OTG) on NuMaker-PFM-M487 board for USB OTG application use.

2.5.4 Ethernet Connectors

- **CN1:** Ethernet connector (RJ-45) on NuMaker-PFM-M487 board for application use.

2.5.5 Arduino UNO Compatible Interface Connectors

- **NU1, NU2, NU5, NU6 and NU7:** Arduino UNO compatible pins on the NuMaker-PFM-M487 board.

2.5.6 Extended Connectors

- **JP6, JP7, JP8 and JP9:** Extended connectors interface pins on the NuMaker-PFM-M487 board.

2.5.7 Phone Jack

- **CN2:** Phone jack connector on NuMaker-PFM-M487 for audio application use.

2.5.8 MicroSD Card Slot

- **U9:** MicroSD card slot for application use.

2.5.9 Push-Buttons

- **SW1:** Reset button to reset the target chip on NuMaker-PFM-M487 board.
- **SW2, SW3:** Only for application use.

2.5.10 LEDs

- **POWER:** The power LED indicates that the NuMaker-PFM-M487 board is powered.
- **I/O1, I/O2 and I/O3:** Only for application use.

2.5.11 Heartbeat Sensor Pads

- **Heartbeat L:** The heartbeat sensor pad on the left hand.
- **Heartbeat R:** The heartbeat sensor pad on the right hand.

2.5.12 Power Connectors

- **JP2, JP3:** 3VCC connectors on the NuMaker-PFM-M487 board.
- **JP4, JP5, JP10 and JP11:** GND connectors on the NuMaker-PFM-M487 board.

2.6 Audio

NuMaker-PFM-M487 features a Nuvoton NAU88L25 audio codec which is an ultra-low power high performance audio codec designed for headphone or headset application. It includes one I2S/PCM interface, one high quality stereo DACs, one mono ADC, a Class G stereo headphone amplifier, and industry leading advanced headset features.

The NAU88L25 connects to the NuMaker-PFM-M487 via I²C bus (M487 is I2C master) for control, the I²C address of NUA88L25 is 0x1A by default, and via I²S bus (M487 is I2S slave) for audio digital data. The Table 2-6 shows the pin mapping between NUC88L25 and M487JIDAE.

Table 2-6 NAU88L25 Mapping with M487JIDAE

NuMaker-PFM-M487	NAU88L25	Comment
I2C2_SCL	SCLK	I ² C clock output Note: The I ² C address of NAU88L25 is 0x1A by default.
I2C2_SDA	SDIO	I ² C data input/output Note: The I ² C address of NAU88L25 is 0x1A by default.
I2S0_BCLK	BCLK	I ² S bit clock output from NAU88L25
I2S0_MCLK	MCLK	I ² S master clock output from M487
I2S0_DI	ADCOUT	I ² S data input to NAU88L25
I2S0_DO	DACIN	I ² S data output from M487
I2S0_LRCK	FS	I ² S left right channel clock output from NAU88L25
PC.13	JKDET	To detect phone jack insertion and ejection
PE.13	JKEN#	To control phone jack output

The 3.5mm phone jack CN2 is used to attach the headset with microphone, the Figure 2-5 shows the phone jack diagram.

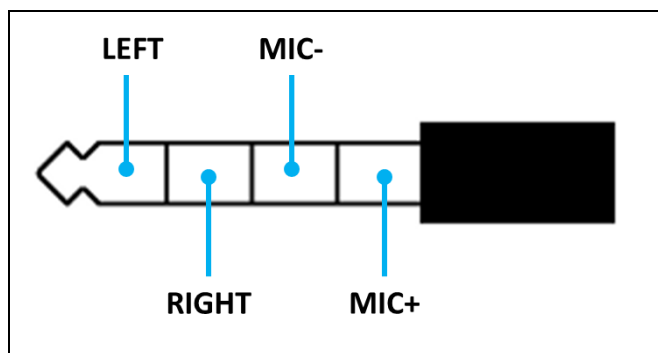

Figure 2-5 3.5mm Phone Jack Diagram

2.7 Heartbeat Sensor

NuMaker-PFM-M487 features an on-board heartbeat sensor, it can detect the tiny electrical signal between human's right and left hand during each heartbeat. The tiny electrical signal passes through three stages of operational amplifiers which are built in M487JI8AE to amplify the differential electrical signal and filter the noise of environment. The Figure 2-6 shows the heartbeat sensor block diagram.

- Heartbeat R/L Sensor Pads**
 The heartbeat sensor pads are used to detect the tiny electrical signal between human's right and left hand during each heartbeat.
- OPA0 (Differential Amplifier and Filter)**
 OPA0 is used to amplify the differential electrical signal between right and left sensor pads and filter the DC bias then passes it to OPA1.
- OPA1 (Bypass Filter and Input Buffer)**
 OPA1 is a bypass filter which is used to suppress 60Hz noise and pass the signal without the noise to OPA2.
- OPA2 (Amplifier)**
 OPA2 is used to amplify the signal comes from OPA1 then passes it to the ADC channel of M487JI8AE to convert the analog signal to the digital signal.

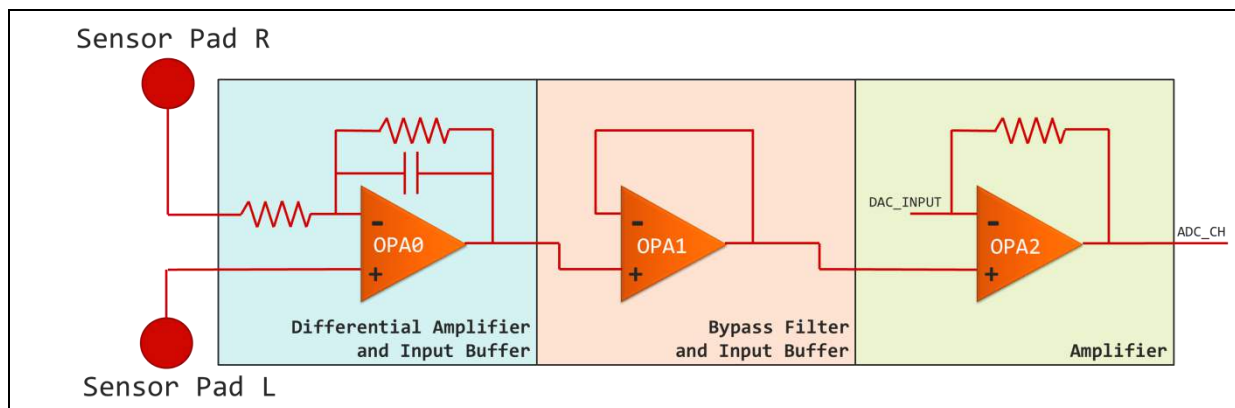

Figure 2-6 Heartbeat Sensor Block Diagram

The pins of heartbeat sensor are share with other function of NuMaker-PFM-M487, the Table 2-7 shows the usage of heartbeat sensor.

Table 2-7 Pin Usage of Heartbeat Sensor

M487JIDAE	Heartbeat Sensor	Alternative Function	Comment
PB.2	OPA0_O	D0	Short R69 to use the heartbeat function, otherwise it will be D0 of UNO Interface.
PB.1	OPA0_N	A5	Short R70 to use the heartbeat function, otherwise it will be A5 of UNO Interface.
PB.0	OPA0_P	A4	Short R71 to use the heartbeat function, otherwise it will be A4 of UNO Interface.
PA.10	OPA1_O	ICSP_CLK	Short R72 to use the heartbeat function, otherwise it will be CLK of UNO ICSP Interface.
PA.9	OPA1_N	ICSP_MISO	Short R73 to use the heartbeat function, otherwise it will be MISO of UNO Interface.
PA.8	OPA1_P	ICSP_MOSI	Short R74 to use the heartbeat function, otherwise it will be MOSI of UNO Interface.
PD.12	OPA2_O	-	Short R75 to use the heartbeat function, otherwise it will be PD.12 of M487JIDAE.
PD.11	OPA2_N	-	Short R76 to use the heartbeat function, otherwise it will be PD.11 of M487JIDAE.
PD.10	OPA2_P	-	Short R77 to use the heartbeat function, otherwise it will be PD.10 of M487JIDAE.
PB.12	DAC0_OUT	ICE_RXD	Short R68 to use the heartbeat function, otherwise it will be ICE_RXD of M487JIDAE.
PB.14	EADC0_CH14	-	Short R60 to use the heartbeat function, otherwise it will be PB.14 of M487JIDAE.

2.8 Nu-Link-Me

NuMaker-PFM-M487 features a Nu-Link-Me ICE debugger and programmer, it provide user to program M487J18AE and debug their application via SWD interface, or it can emulate a USB pen driver when connect to the PC, user can update their firmware by pulling bin file to the pen driver. Nu-link-Me can also emulate a virtual COM port, user can log or print debug message via it. Refer Table 2-8 to enable or disable optional function of Nu-Link-Me.

Table 2-8 Optional Function of Nu-Link-Me

ISW1		
Pin	Nu-Link-Me	Comment
1	TXD	On: Connect PB.13 (UART0_TXD) of M487J18AE to Nu-Link-Me. Off: Disconnect PB.13 (UART0_TXD) of M487J18AE to Nu-Link-Me.
2	RXD	On: Connect PB.12 (UART0_RXD) of M487J18AE to Nu-Link-Me. Off: Disconnect PB.12 (UART0_RXD) of M487J18AE to Nu-Link-Me.
3	VCOM	On: Enable Nu-Link-Me virtual COM port function. Off: Disable Nu-Link-Me virtual COM port function.
4	MSG	On: Mass storage mode, user can update firmware by pulling bin file to pen driver Off: Normal ICE mode, user can debugger and program via SWD interface..

2.9 PCB Placement

Figure 2-7 and Figure 2-8 show the front and rear placement of NuMaker-PFM-M487 board.

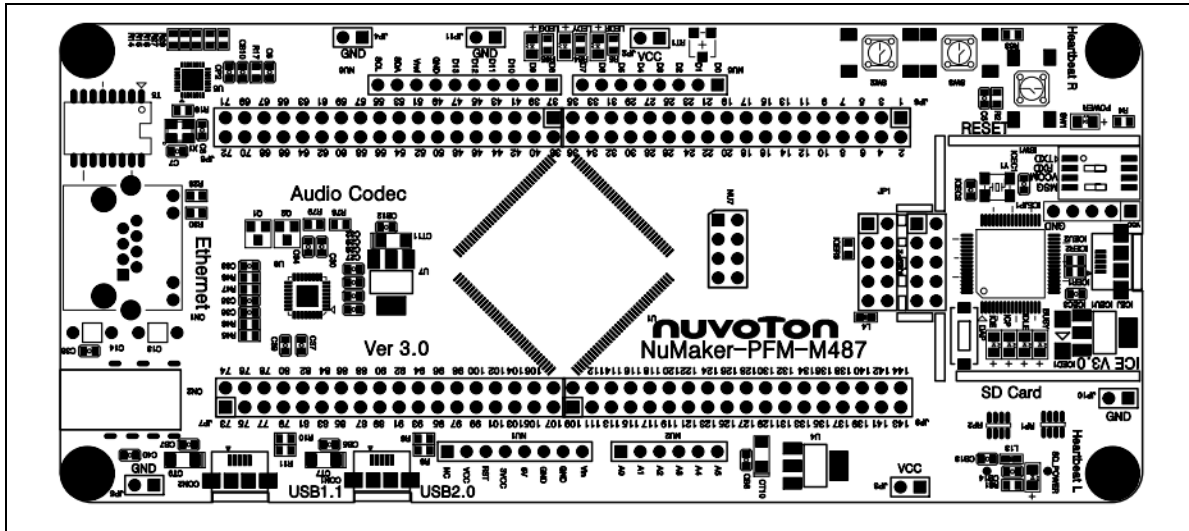

Figure 2-7 Front Placement

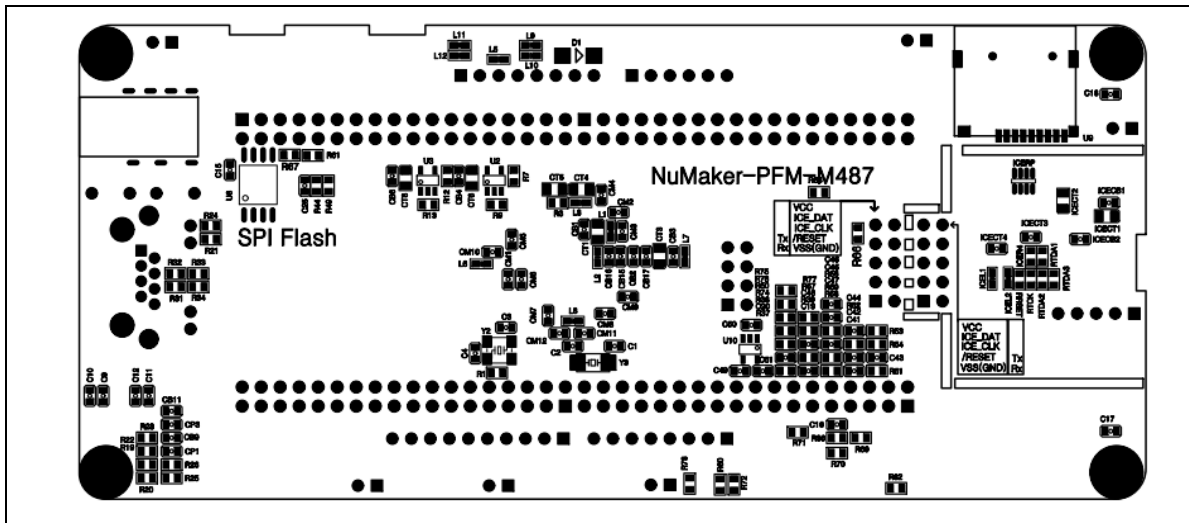

Figure 2-8 Rear Placement

3 NUMAKER-PFM-M487 SCHEMATICS

3.1 Nu-Link-Me

Figure 3-1 shows the Nu-Link-Me circuit, which is a USB-to-SWD bridge used to program code to the target chip.

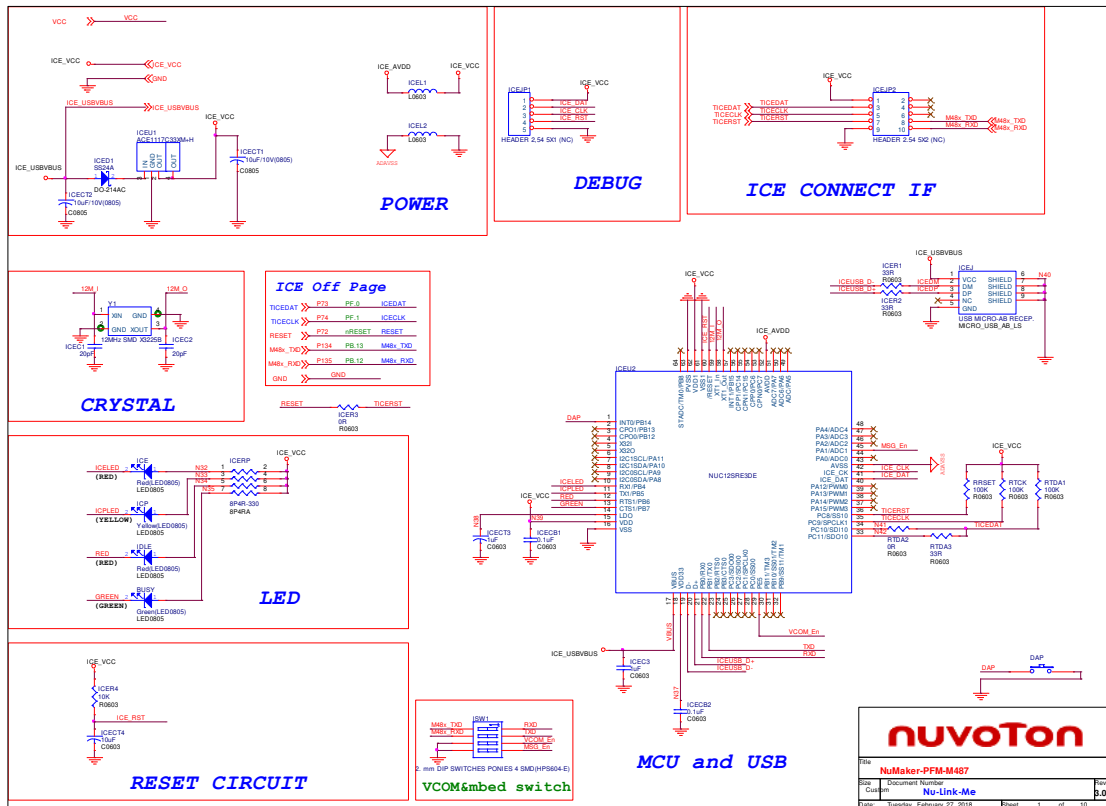

Figure 3-1 Nu-Link-Me Circuit

3.2 M487JIDAE

Figure 3-2 shows the pin assignment of the M487J8AE.

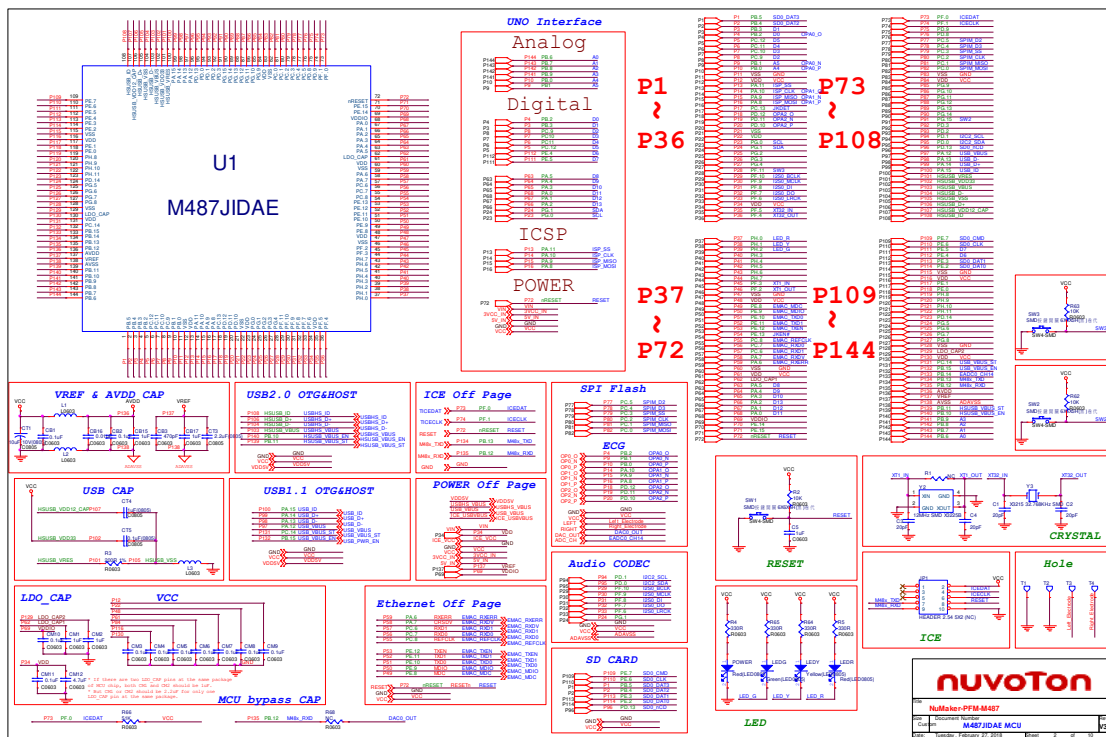

Figure 3-2 M487J8AE Pin Assignment

3.3 Power Supply

Figure 3-3 shows power configurations of NuMaker-PFM-M487 board.

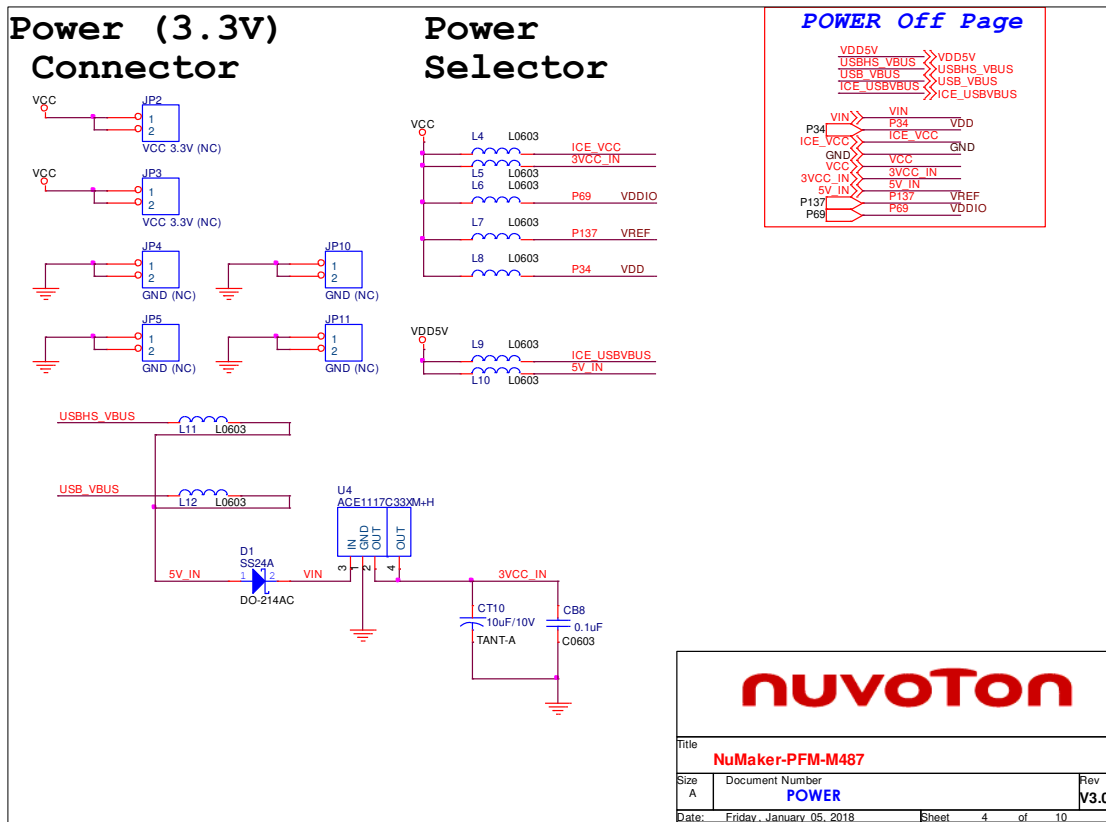

Figure 3-3 Power Circuit and Configurations

NUMAKER-PFM-M487 USER MANUAL

3.4 Arduino UNO Compatible Interface

Figure 3-4 shows the Arduino UNO compatible interface of NU1 to NU5 connectors.

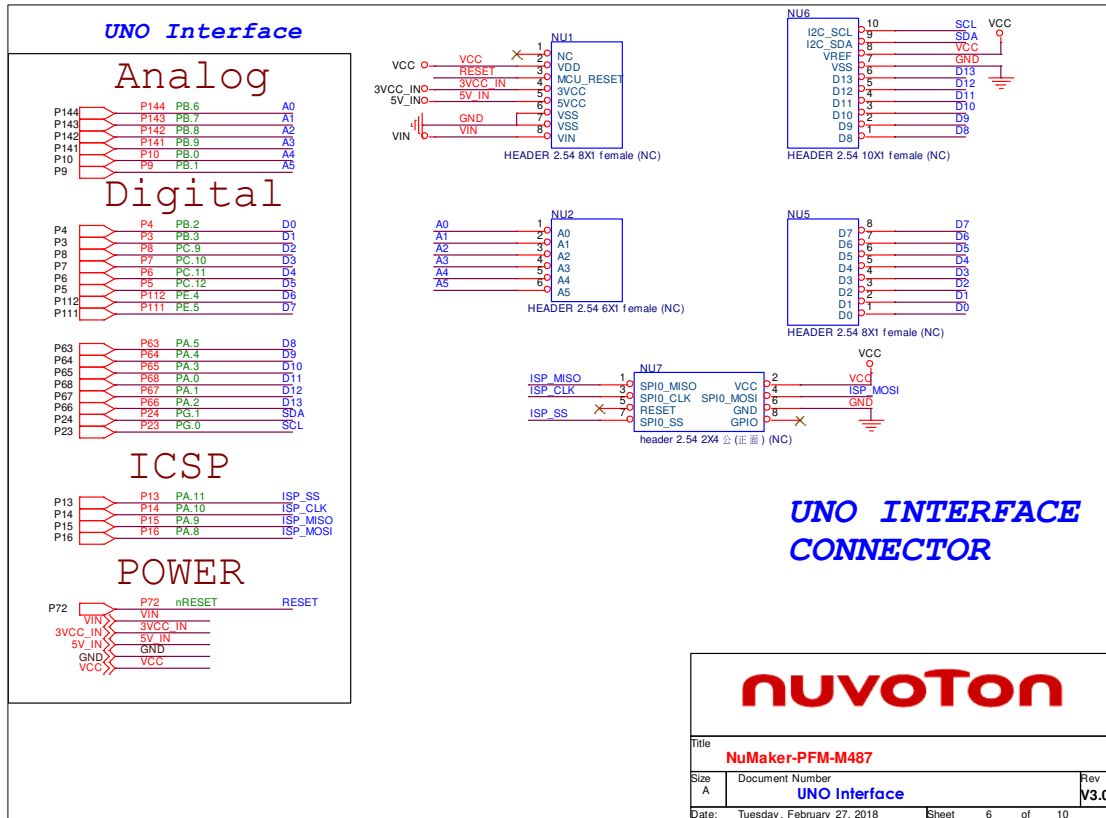

Figure 3-4 Arduino UNO Compatible Interface

3.5 Reset

Figure 3-5 shows the reset circuit for the M487J18AE.

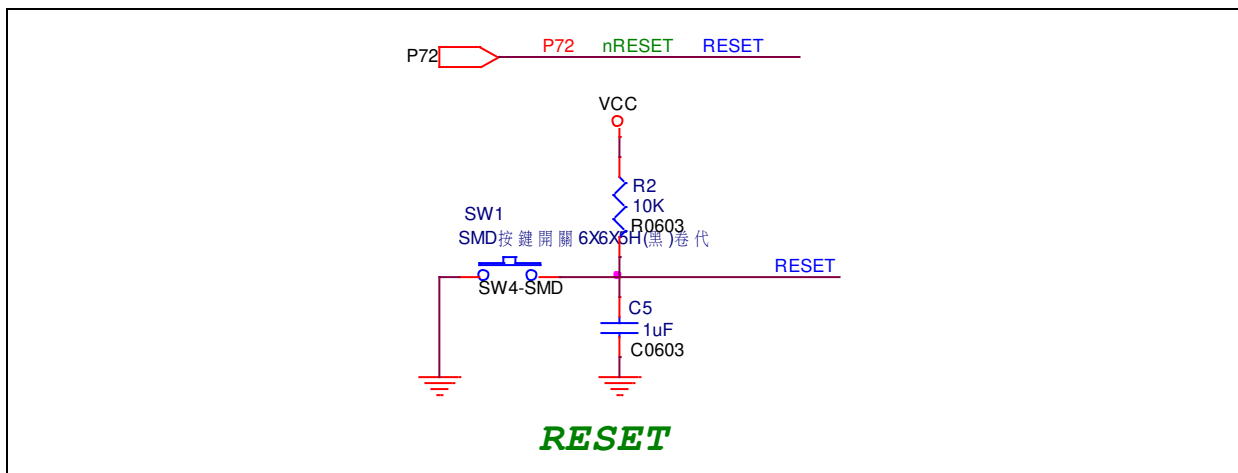

Figure 3-5 Reset Circuit

3.6 Crystal

Figure 3-6 shows two external crystal circuits for the M487J18AE.

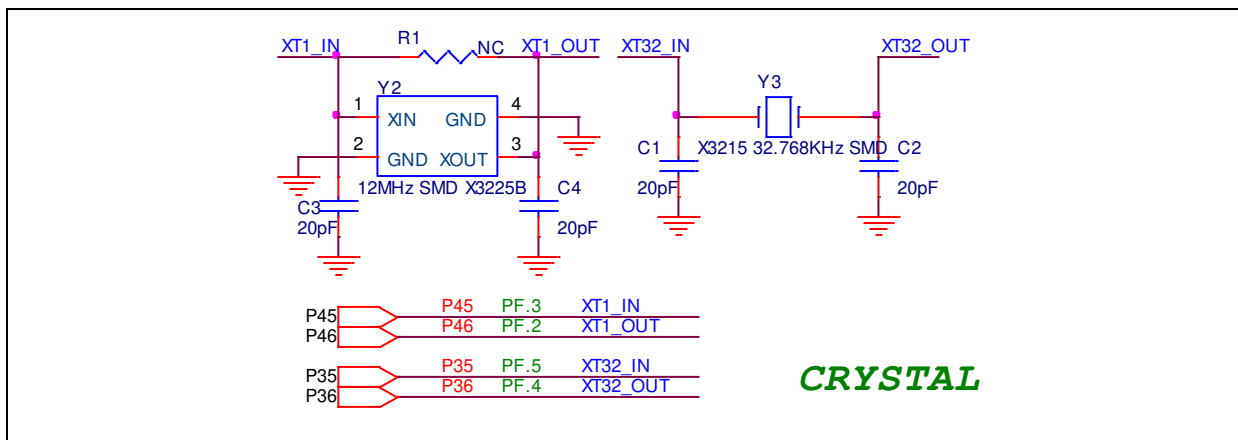

Figure 3-6 External Crystal Circuit

3.7 LEDs

Figure 3-7 shows the power LED and three IO LEDs that be controlled by PH.0, PH.1 and PH.2 pins of the M487JI8AE.

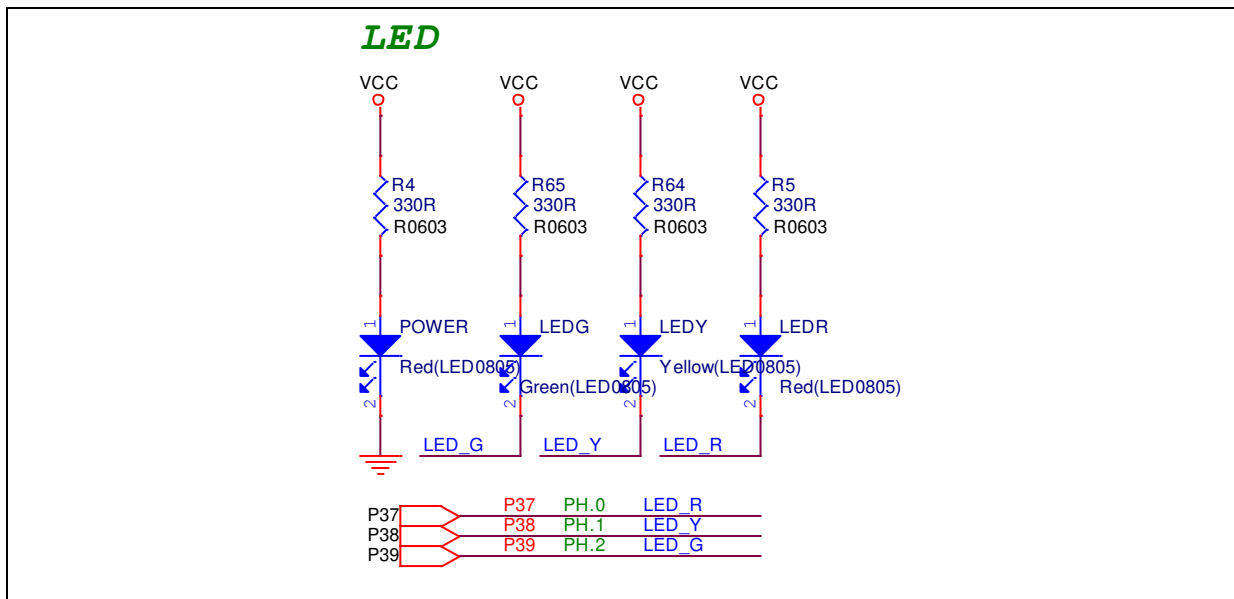

Figure 3-7 Power LED and IO LED Circuit

3.8 Push-Buttons

Figure 3-8 shows the push-buttons circuit on the NuMaker-PFM-M487 board.

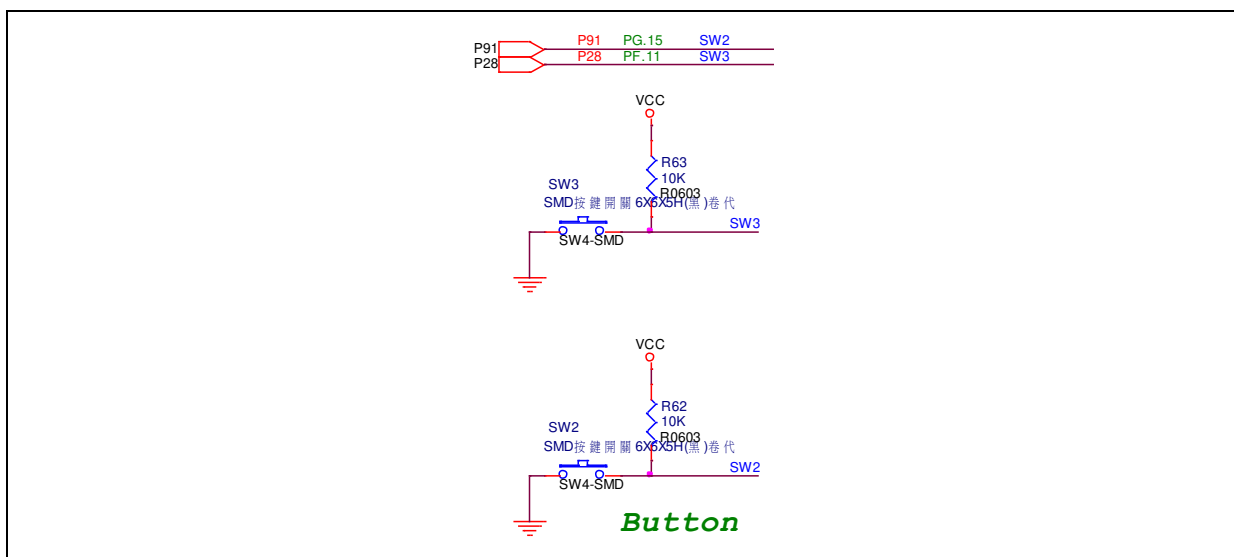

Figure 3-8 Push-Buttons Circuit

3.9 MicroSD Card

Figure 3-9 shows the MicroSD Card circuit on the NuMaker-PFM-M487 board.

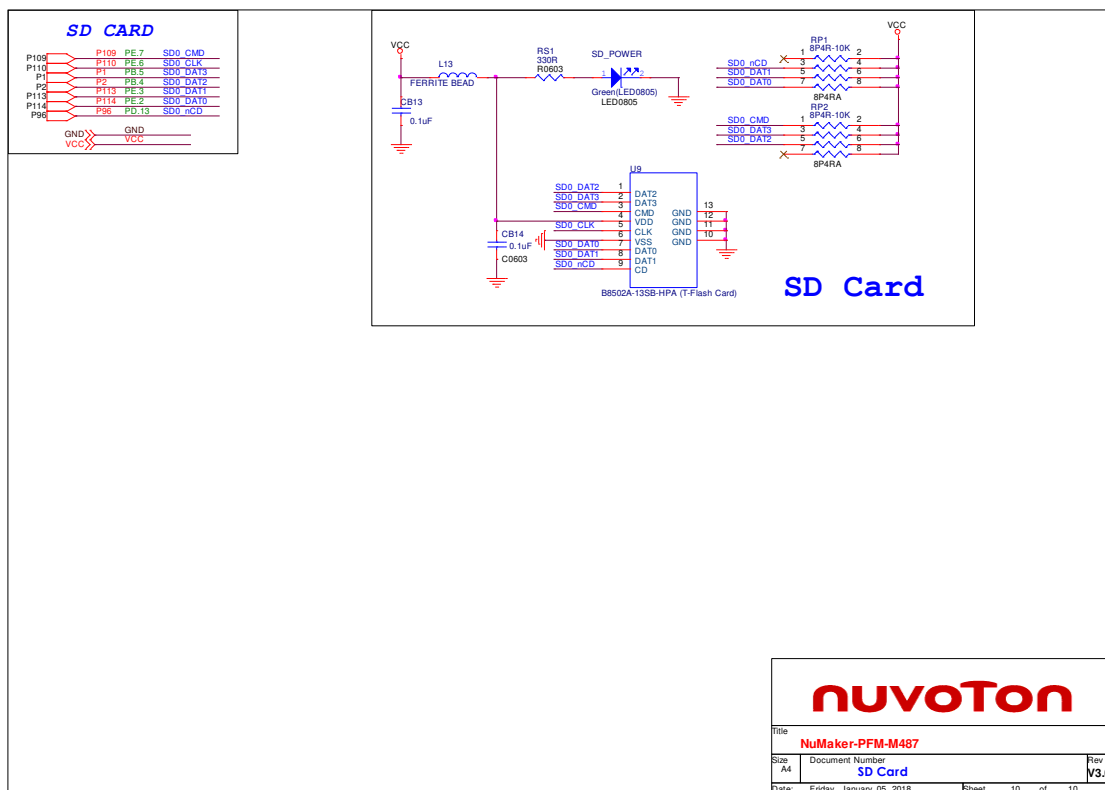

Figure 3-9 MicroSD Card Circuit

3.10 USB 2.0 HS OTG and USB 1.1 FS OTG

Figure 3-10 shows the USB 2.0 HS OTG and USB 1.1 FS OTG circuits on the NuMaker-PFM-M487 board.

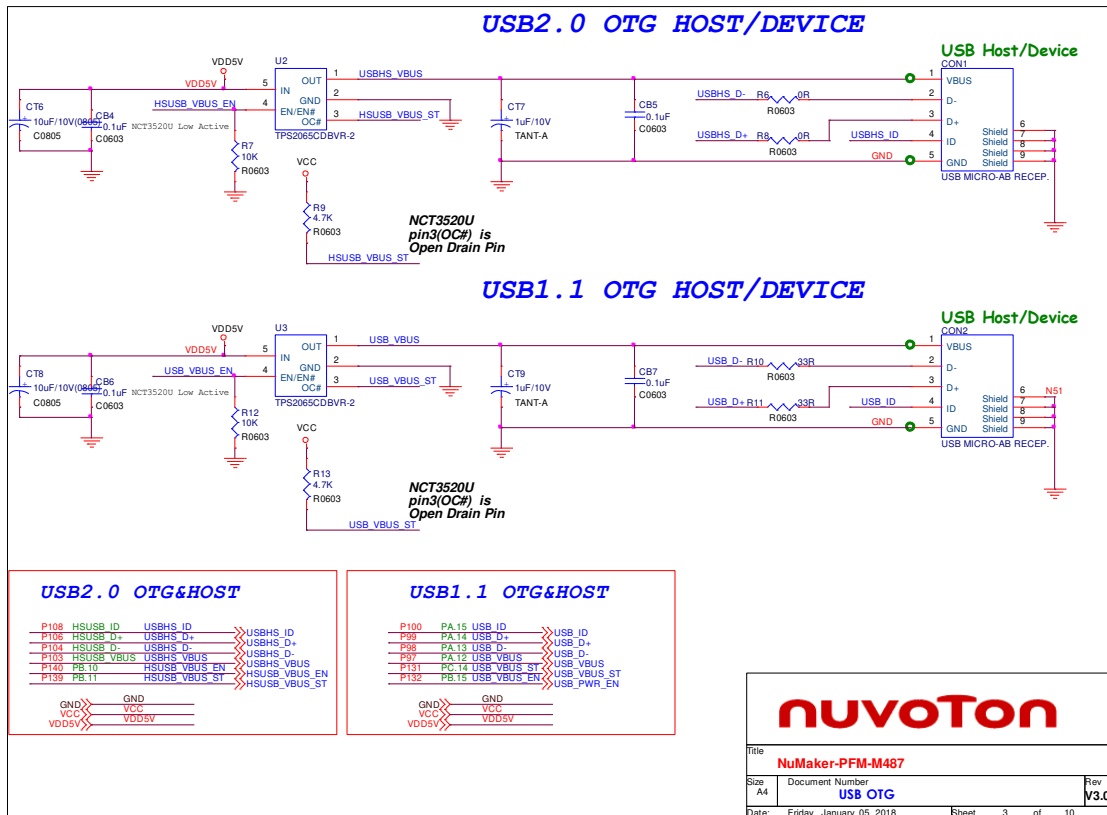

Figure 3-10 USB HS OTG and FS OTG Circuits

3.11 Ethernet

Figure 3-11 shows the Ethernet interface for networking application on the NuMaker-PFM-M487 board.

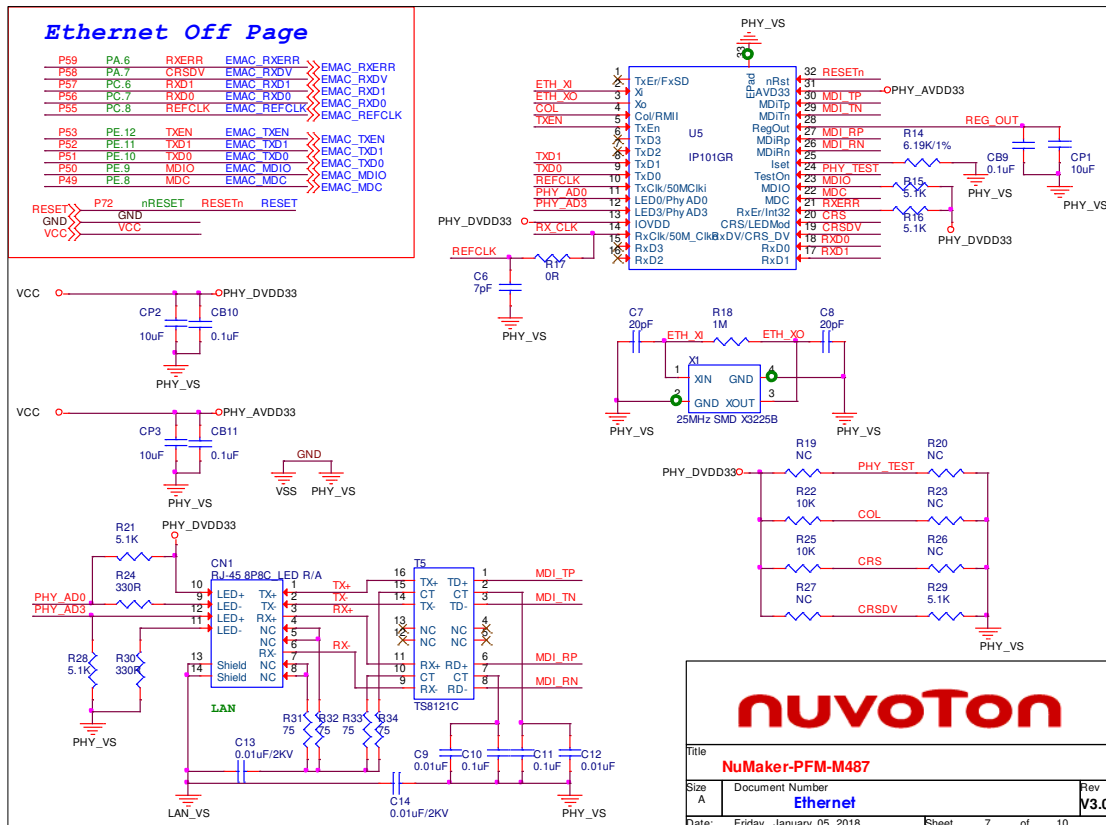

Figure 3-11 Ethernet Circuit

3.12 24-bit Stereo Audio Codec

Figure 3-12 shows the audio codec application circuit based on NAU88L25 to simplify implementation of complete audio system solutions.

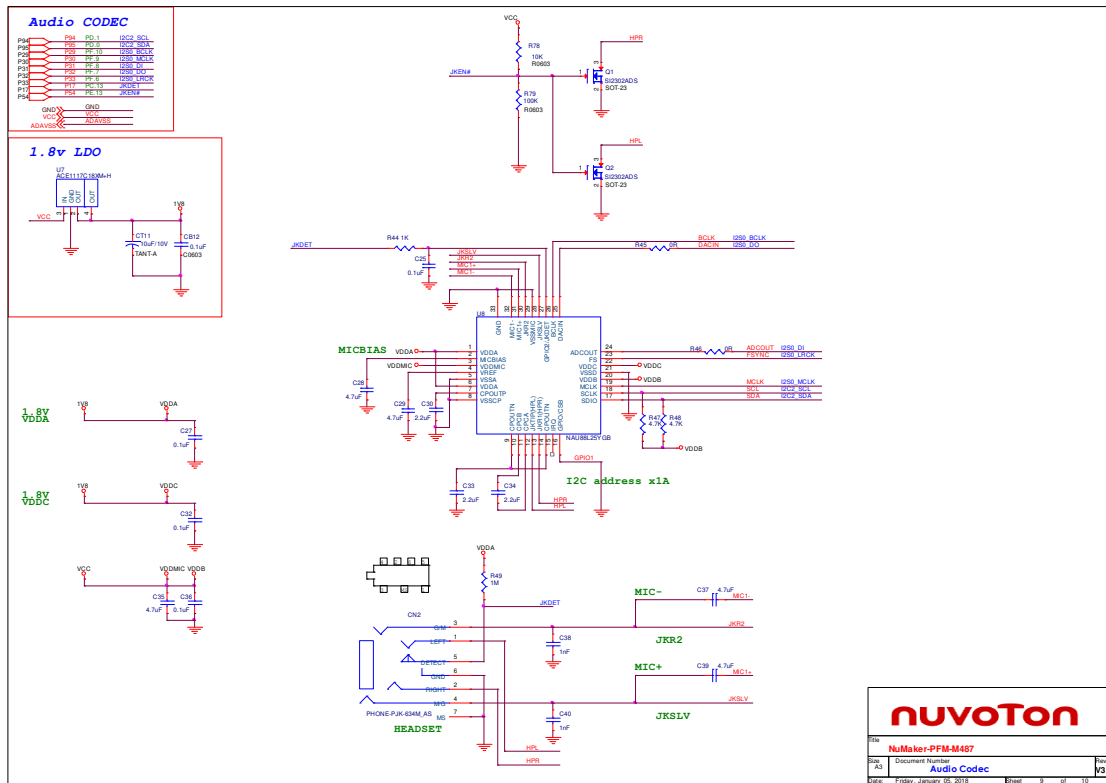

Figure 3-12 Audio Codec Circuit

3.13 Heartbeat Sensor and SPI Flash

Figure 3-13 shows the heartbeat sensor application circuit and the SPI flash circuit on the NuMaker-PFM-M487 board.

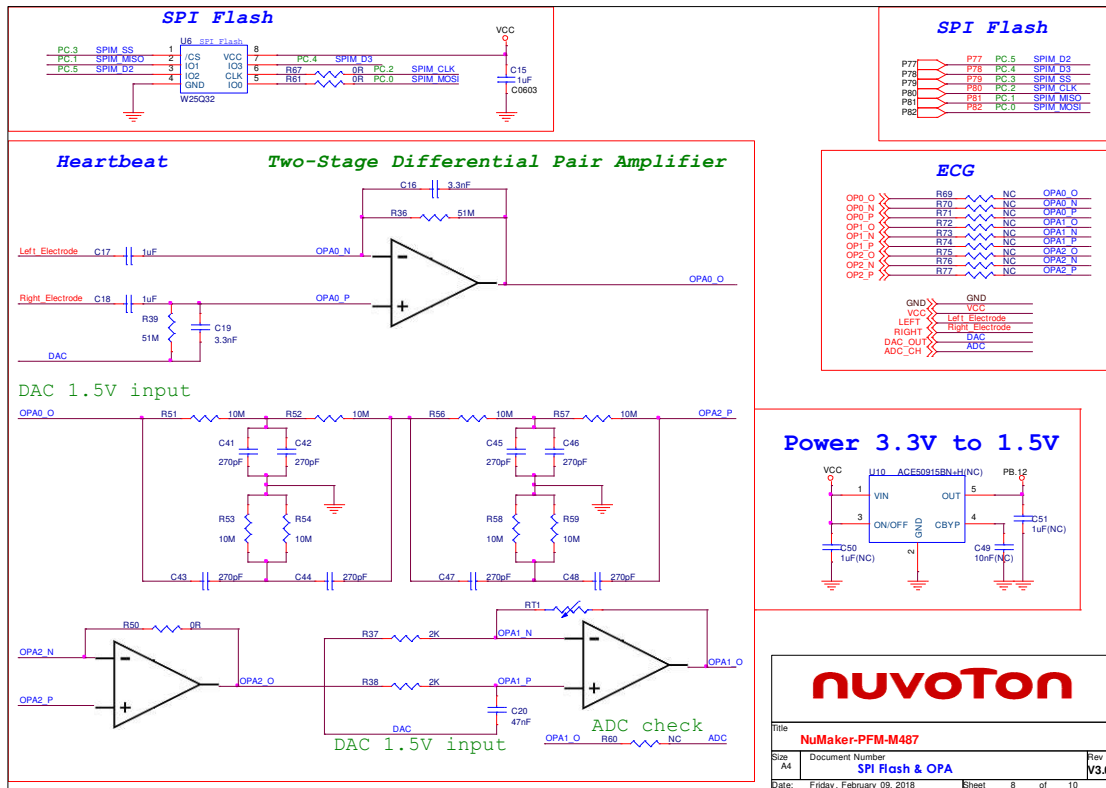

Figure 3-13 Heartbeat Sensor and SPI Flash Circuits

4 REVISION HISTORY

Date	Revision	Description
2018.04.19	1.00	1. Initially issued.
2019.04.02	1.01	1. Corrected Table 2-8.

Important Notice

Nuvoton Products are neither intended nor warranted for usage in systems or equipment, any malfunction or failure of which may cause loss of human life, bodily injury or severe property damage. Such applications are deemed, "Insecure Usage".

Insecure usage includes, but is not limited to: equipment for surgical implementation, atomic energy control instruments, airplane or spaceship instruments, the control or operation of dynamic, brake or safety systems designed for vehicular use, traffic signal instruments, all types of safety devices, and other applications intended to support or sustain life.

All Insecure Usage shall be made at customer's risk, and in the event that third parties lay claims to Nuvoton as a result of customer's Insecure Usage, customer shall indemnify the damages and liabilities thus incurred by Nuvoton.

*Please note that all data and specifications are subject to change without notice.
All the trademarks of products and companies mentioned in this datasheet belong to their respective owners.*