

DEMO CIRCUIT 1710A-D QUICK START GUIDE

LTC5593

Dual 2.3GHz to 4.5GHz
HIGH DYNAMIC RANGE
DOWNCONVERTING MIXER



DESCRIPTION

Demonstration Circuit 1710A-D is a dual 2.3GHz to 4.5GHz high dynamic range downconverting mixer featuring the LTC[®]5593. The LTC5593 is part of a family of dual-channel high dynamic range, high gain downconverting mixers covering the 600MHz to 4.5GHz frequency range. **The Demo Circuit 1710A-D and the LTC5593 are optimized for 2.3GHz to 4.5GHz RF applications. The LO frequency must fall within the 2.1GHz to 4.2GHz range for optimum performance.** A typical application is a LTE or WiMAX multichannel or diversity receiver with a 2.3GHz to 2.7GHz RF input.

The LTC5593 is designed for 3.3V operation, however the IF amplifiers can be powered by 5V for the highest P1dB. A low current mode is provided for power savings, and each of the mixer channels has independent shutdown control.

The LTC5593's high conversion gain and high dynamic range enable the use of lossy IF filters in high-selective receiver designs, while minimizing the total solution cost, board space and system-level variation.

High Dynamic Range Dual Downconverting Mixer Family

DEMO #	IC PART #	RF RANGE	LO RANGE
DC1710A-A	LTC5590	600MHz-1.7GHz	700MHz-1.5GHz
DC1710A-B	LTC5591	1.3GHz-2.3GHz	1.4GHz-2.1GHz
DC1710A-C	LTC5592	1.6GHz-2.7GHz	1.7GHz-2.5GHz
DC1710A-D	LTC5593	2.3GHz-4.5GHz	2.1GHz-4.2GHz

Design files for this circuit board are available. Call the LTC factory.

LT, LTC, LTM, Linear Technology and the Linear Logo are registered trademarks of Linear Technology Corporation. All other trademarks are the property of their respective owners.

APPLICATIONS NOTE

For detailed applications information, please refer to the LTC5593 datasheet.

ABSOLUTE MAXIMUM RATINGS

NOTE. Stresses beyond Absolute Maximum Ratings may cause permanent damage to the device. Exposure to any Absolute Maximum Rating condition for extended periods may affect device reliability and lifetime.

Supply Voltage (VCC)	4.0V
IF Supply Voltage (VCCIF)	5.5V
Enable Voltage (ENA, ENB)	-0.3V to V _{CC} + 0.3V
Bias Adjust Voltage (IFBA, IFBB)	-0.3V to V _{CC} + 0.3V
Power Select Voltage (ISEL).....	-0.3V to V _{CC} + 0.3V
LO Input Power (1GHz to 3GHz)	9dBm
RFA, RFB Input Power (1GHz to 3GHz).....	15dBm
Operating Temperature Range	-40°C to 105°C

SUPPLY VOLTAGE RAMPING

Fast ramping of the supply voltage can cause a current glitch in the internal ESD protection circuits. Depending on the supply inductance, this could result in a supply voltage transient that exceeds the maximum rating. A supply voltage ramp time of greater than 1ms is recommended.

Do not clip powered test leads directly onto the demonstration circuit's VCC and VCCIF turrets. Instead, make all necessary connections with power supplies turned off, then increase to operating voltage.

ENABLE FUNCTION

The LTC5593's two mixer channels can be independently enabled or disabled. When the Enable voltage (ENA or ENB) is logic high (>2.5V), the corresponding mixer channel is enabled. When the Enable voltage is logic low (<0.3V), the mixer channel is disabled. The voltages at the enable pins should never fall below -0.3V or exceed the power supply voltage by more than 0.3V. The En-

able pins must be pulled high or low. If left floating, the on/off state of the IC will be indeterminate. A logic table for the Enable control (ENA, ENB) is shown in Table 1.

TABLE 1. ENABLE CONTROL LOGIC TABLE

ENA, ENB	MIXER CHANNEL STATE
Low	Disabled
High	Enabled

LOW CURRENT MODE

The LTC5593 features a low current mode, which allows the flexibility to choose a 37% total power saving when lower RF performance is acceptable. When the ISEL voltage is logic low (<0.3V), both mixer channels operate at nominal DC current and best performance. When the ISEL voltage is logic high (>2.5V), both mixer channels are in low current mode and operate with reduced performance. The ISEL voltage should never fall below -0.3V or exceed the power supply voltage by more than 0.3V. The ISEL pin must be pulled low or high. If left floating, the operating current state of the IC will be indeterminate. A logic table for ISEL is shown in Table 2.

TABLE 2. ISEL LOGIC TABLE

ISEL	OPERATING MODE
Low	Normal current, best performance
High	Low current, reduced performance

RF INPUTS

Demonstration Circuit 1710A-D's RF inputs of channel A and channel B are identical. **For the RF inputs to be matched, the appropriate LO signal must be applied.** The RF inputs' impedance is dependent on LO frequency, but the Demonstration Circuit 1710A-D's RF inputs are well matched to 50Ω from 2.3GHz to 4.5GHz, with better than 12dB return loss, when a 2.1GHz to 4.2GHz LO signal is applied.

LO INPUTS

Demonstration Circuit 1710A-D's LO input is well matched to 50Ω from 2.1GHz to 3.4GHz, with bet-

ter than 12dB return loss. For LO frequency from 3.4GHz to 3.8GHz, the LO port can be well matched by using $C2 = 0.6\text{pF}$ and $L4 = 10\text{nH}$.

The LTC5593's LO amplifiers are optimized for the 2.1GHz to 4.2GHz LO frequency range. LO frequencies above and below this frequency range may be used with degraded performance. The LO input is always 50Ω -matched when VCC is applied to the chip, even when one or both of the channels is disabled. The nominal LO input level is 0dBm. The LO input power range is between -4dBm and 6dBm.

IF OUTPUT

Demonstration Circuit 1710A-D features single-ended, 50Ω -matched IF outputs for 190MHz. The channel A and the channel B IF outputs are identical, and the impedance matching is realized with a bandpass topology using IF.

Demonstration Circuit 1710A-D can be easily re-configured for other IF frequencies by simply replacing inductors L1A, L2A, L1B and L2B. Inductor values for several common IF frequencies are presented in Table 3. External load resistor, R2A and R2B, can be used to improve impedance matching if desired.

TABLE 3. INDUCTOR VALUES vs. IF FREQUENCIES

IF FREQUENCY (MHz)	L1A, L2A, L1B, L2B (nH)
140	270
190	150
240	100
300	56
380	33
470	22

MEASUREMENT EQUIPMENT AND SETUP

The LTC5593 is a dual high dynamic range down-converting mixer IC with very high input 3rd order intercept. Accuracy of its performance measurement is highly dependent on equipment setup and measurement technique. The recommended measurement setups are presented in Figure 5, Figure 6, and Figure 7. The following precautions should be observed:

1. Use high performance signal generators with low harmonic output and low phase noise, such as the Rohde & Schwarz SME06. Filters at the signal generators' outputs may also be used to suppress higher-order harmonics.
2. A high quality RF power combiner that provide broadband 50Ω -termination on all ports and have good port-to-port isolation should be used, such as the MCLI PS2-17.
3. Use high performance amplifiers with high IP3 and high reverse isolation, such as the Mini-Circuits ZHL-1042J, on the outputs of the RF signal generators to improve source isolation to prevent the sources from modulating each other and generating intermodulation products.
4. Use attenuator pads with good VSWR on the demonstration circuit's input and output ports to improve source and load match to reduce reflections, which may degrade measurement accuracy.
5. A high dynamic range spectrum analyzer, such as the Rohde & Schwarz FSEM30, should be used for linearity measurement.
6. Use narrow resolution bandwidth (RBW) and engage video averaging on the spectrum analyzer to lower the displayed average noise level (DANL) in order to improve sensitivity and to increase dynamic range. However, the trade off is increased sweep time.
7. Spectrum analyzers can produce significant internal distortion products if they are over-

driven. Generally, spectrum analyzers are designed to operate at their best with about -30dBm at their input filter or preselector. Sufficient spectrum analyzer input attenuation should be used to avoid saturating the instrument, but too much attenuation reduces sensitivity and dynamic range.

8. Before taking measurements, the system performance should be evaluated to ensure that:
 - a. Clean input signals can be produced. The two-tone signals' OIP3 should be at least 15dB better than the DUT's IIP3.
 - b. The spectrum analyzer's internal distortion is minimized.
 - c. The spectrum analyzer has enough dynamic range and sensitivity. The measurement system's IIP3 should be at least 15dB better than the DUT's OIP3.
 - d. The system is accurately calibrated for power and frequency.

A SPECIAL NOTE ABOUT RF TERMINATION

The LTC5593 consists of high linearity passive double-balanced mixer cores and IF buffer amplifiers. Due to the bi-directional nature of all passive mixers, $LO\pm IF$ mixing product is always present at the RF input, typically at a level of 12dB below the RF input signal. If the $LO\pm IF$ "Pseudo-Image Spur" is not properly terminated, it may interfere with the source signals, and can degrade the measured linearity and noise figure significantly. To avoid interference from the $LO\pm IF$ "Pseudo-Image Spur", terminate the RF input port with an isolator, diplexer, or attenuator. In the recommended measurement setups presented in Figure 6 and Figure 7, the 6dB attenuator pad at the demonstration circuit's RF input serves this purpose.

QUICK START PROCEDURE

Demonstration circuit 1710A-D is easy to set up to evaluate the performance of the LTC5593. Refer to Figure 1, Figure 2, and Figure 3 for proper equipment connections. The following procedures describe performing measurements on Mixer Channel A. The measurement procedures for Mixer Channel B are identical.

NOTE. Care should be taken to never exceed absolute maximum input ratings. Make all connections with RF and DC power off.

RETURN LOSS MEASUREMENTS

1. Configure the Network Analyzer for return loss measurement, set appropriate frequency range, and set the test signal to -3dBm.
2. Calibrate the Network Analyzer.
3. Connect all test equipment as shown in Figure 5 with the signal generator and the DC power supply turned off.
4. Increase the DC power supply voltage to 3.3V, and verify that the total current consumption is close to the figure listed in the Typical Demonstration Circuit Performance Summary. The supply voltage should be confirmed at the demo board VCC, VCCIF and GND terminals to account for lead ohmic losses.
5. With the LO signal applied, and all unused demo board ports terminated in 50Ω, measure return losses of the RFA input and IFA output ports.
6. Set the test signal to 0dBm, and re-calibrate the Network Analyzer.
7. Terminate all unused demo board ports in 50Ω. Measure return losses of the LO input port.

RF PERFORMANCE MEASUREMENTS

1. Connect all test equipment as shown in Figure 6 with the signal generators and the DC power supply turned off.
2. Increase the DC power supply voltage to 3.3V, and verify that the total current consumption is close to the figure listed in the Typical Demonstration Circuit Performance Summary. The supply voltage should be confirmed at the demo board VCC, VCCIF and GND terminals to account for lead ohmic losses.
3. Set the LO source (Signal Generator 1) to provide a 0dBm CW signal at appropriate LO frequency to the demo board LO input port.
4. Set the RF sources (Signal Generators 2 and 3) to provide two -3dBm CW signals, 2MHz apart, at the appropriate RF frequencies to the demo board RFA input port.
5. Measure the resulting IFA output on the Spectrum Analyzer:
 - a. The wanted two-tone IF output signals are at:

$$f_{IF1} = f_{RF1} - f_{LO}, \text{ and}$$

$$f_{IF2} = f_{RF2} - f_{LO} \text{ for low-side LO,}$$
 and

$$f_{IF1} = f_{LO} - f_{RF1}, \text{ and}$$

$$f_{IF2} = f_{LO} - f_{RF2} \text{ for high-side LO}$$
 - b. The 3rd order intermodulation products which are closest to the wanted IF signals are used to calculate the Input 3rd Order Intercept:

$$f_{IM3,1} = f_{RF1} - f_{LO} - \Delta_{IF}, \text{ and}$$

$$f_{IM3,2} = f_{RF2} - f_{LO} + \Delta_{IF} \text{ for low-side LO,}$$
 and

$$f_{IM3,1} = f_{LO} - f_{RF1} + \Delta_{IF}, \text{ and}$$

$$f_{IM3,2} = f_{LO} - f_{RF2} - \Delta_{IF} \text{ for high-side LO}$$
 Where $\Delta_{IF} = f_{RF2} - f_{RF1}$.

LTC55933

6. Calculate Input 3rd Order Intercept:

$$IIP3 = (\Delta_{IM3})/2 + P_{RF}$$

Where $\Delta_{IM3} = P_{IF} - P_{IM3}$. P_{IF} is the lowest IF output signal power at either f_{IF1} or f_{IF2} . P_{IM3} is the highest 3rd order intermodulation product power at either $f_{IM3,1}$ or $f_{IM3,2}$. P_{RF} is the per-tone RF input power.

7. Turn off one of the RF signal generators, and measure Conversion Gain, RF to IF isolation, LO to IF leakage, and Input 1dB compression point.

NOISE FIGURE MEASUREMENT

1. Configure and calibrate the noise figure meter for mixer measurements.
2. Connect all test equipment as shown in Figure 7 with the signal generator and the DC power supply turned off.
3. Increase the DC power supply voltage to 3.3V, and verify that the total current consumption is close to the figure listed in the Typical Demonstration Circuit Performance Summary. The supply voltage should be confirmed at the demo board VCC, VCCIF and GND terminals to account for lead ohmic losses.
4. Measure the single-sideband noise figure.

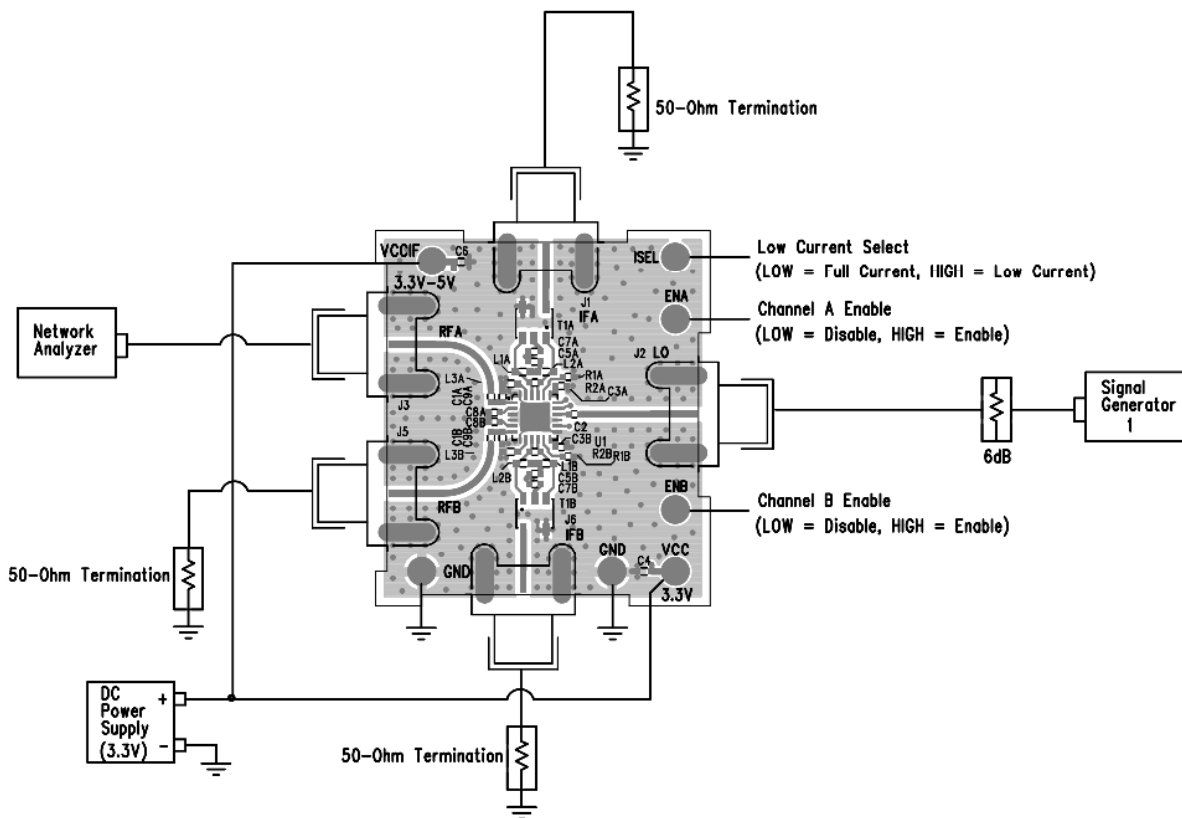

Figure 1. Proper Equipment Setup for Return Loss Measurements

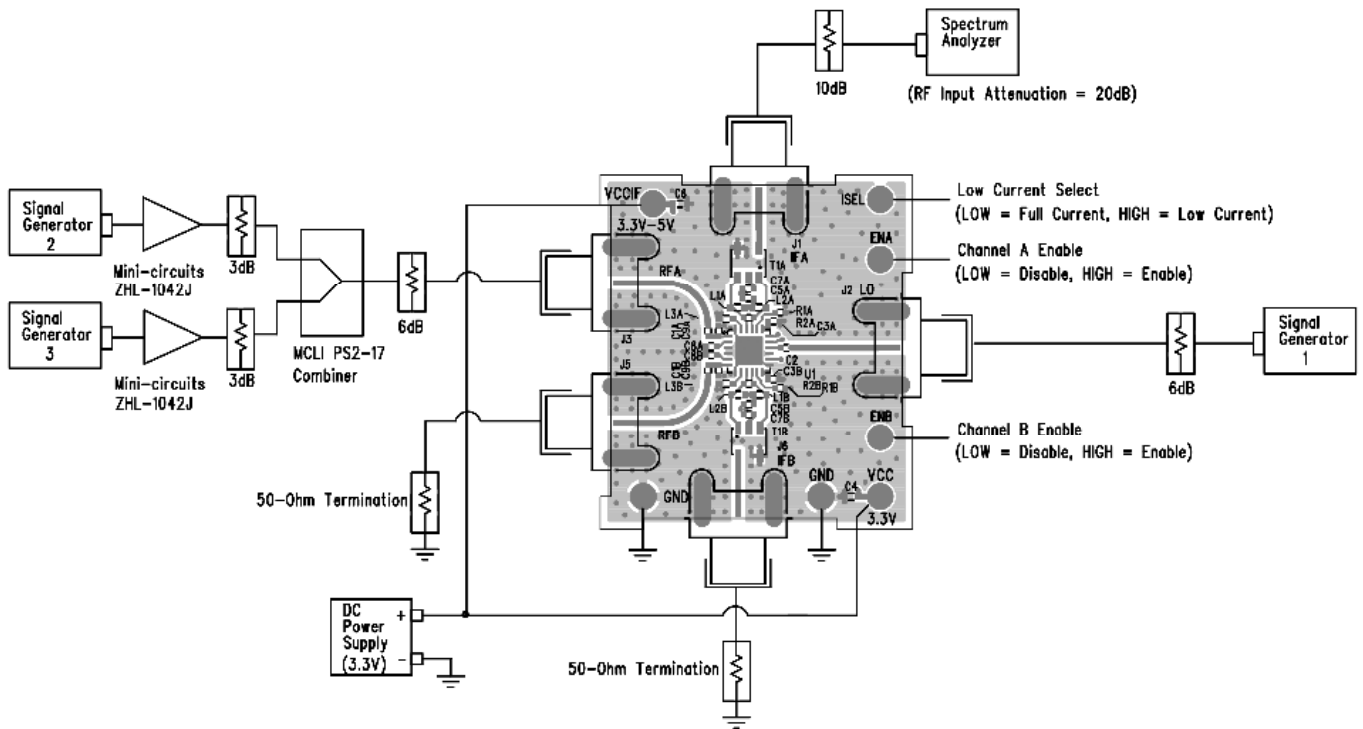

Figure 2. Proper Equipment Setup for RF Performance Measurements

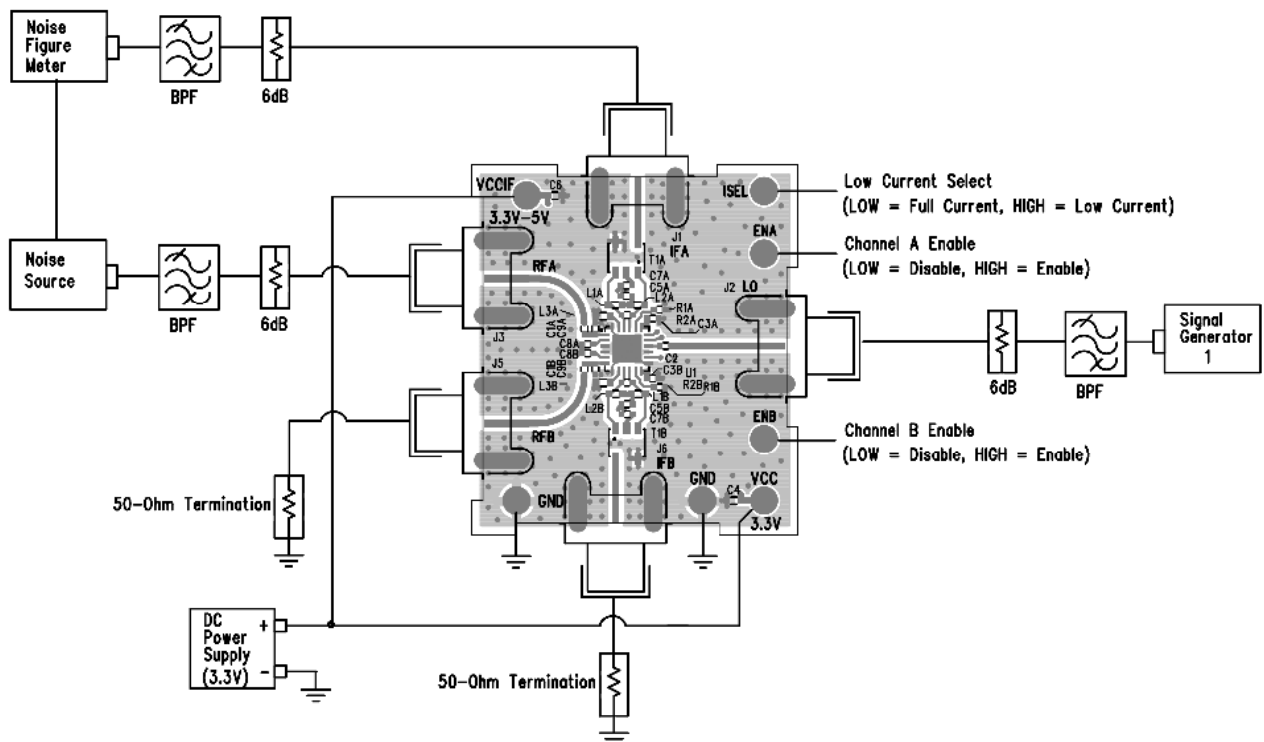

Figure 3. Proper Equipment Setup for Noise Figure Measurement

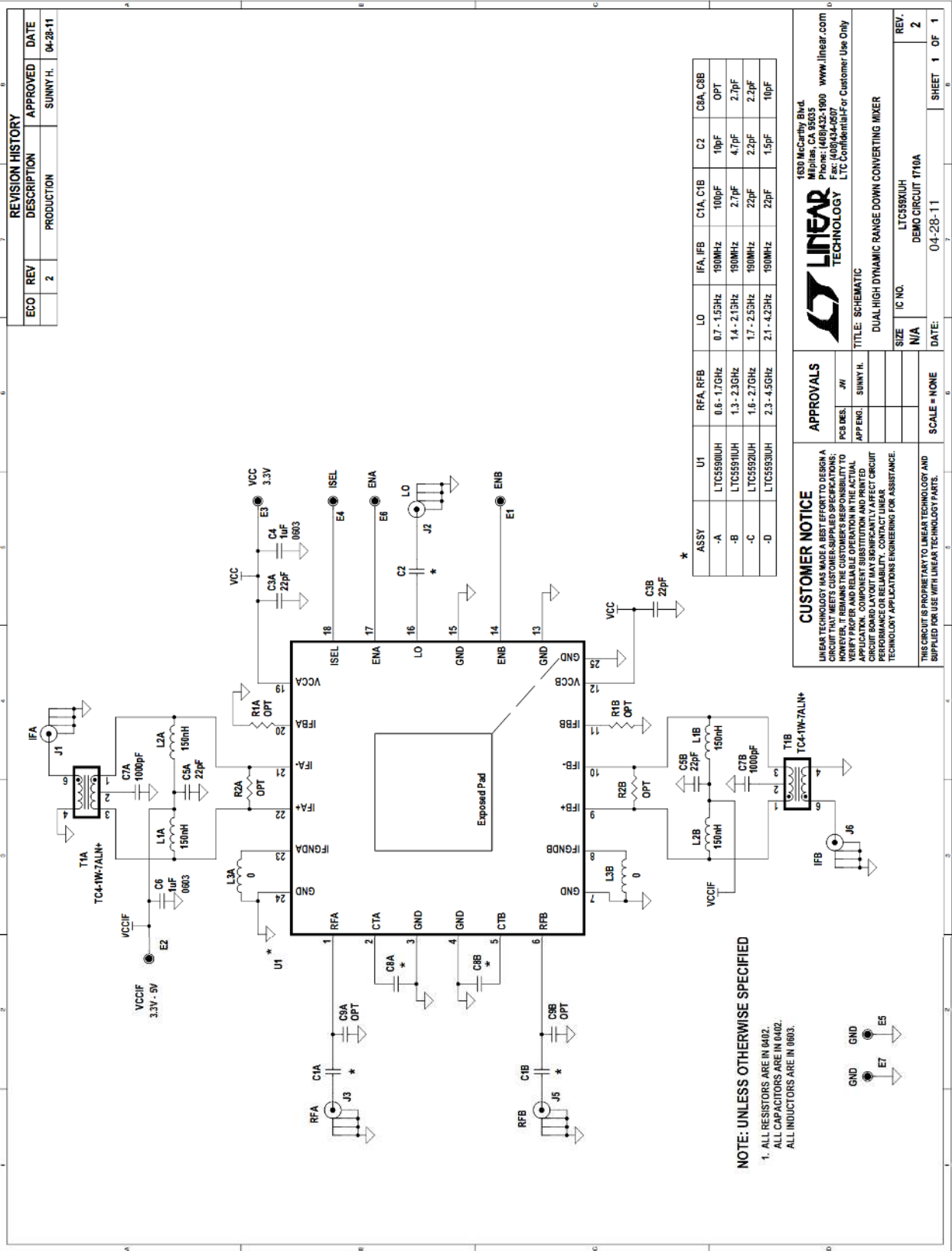

Figure 4. Demonstration Circuit schematic