

THIS DRAWING IS UNPUBLISHED. RELEASED FOR PUBLICATION  
 © COPYRIGHT BY TYCO ELECTRONICS CORPORATION. ALL RIGHTS RESERVED.

LOC	DIST	REVISIONS					
		P	LTR	DESCRIPTION	DATE	DWN	APVD
G	14		A	REV PER 0G3A-0002-04	05MAR04	JR	TM

**AMP**  
WIRE RANGE

22-16 AWG  
SOLID OR STRANDED

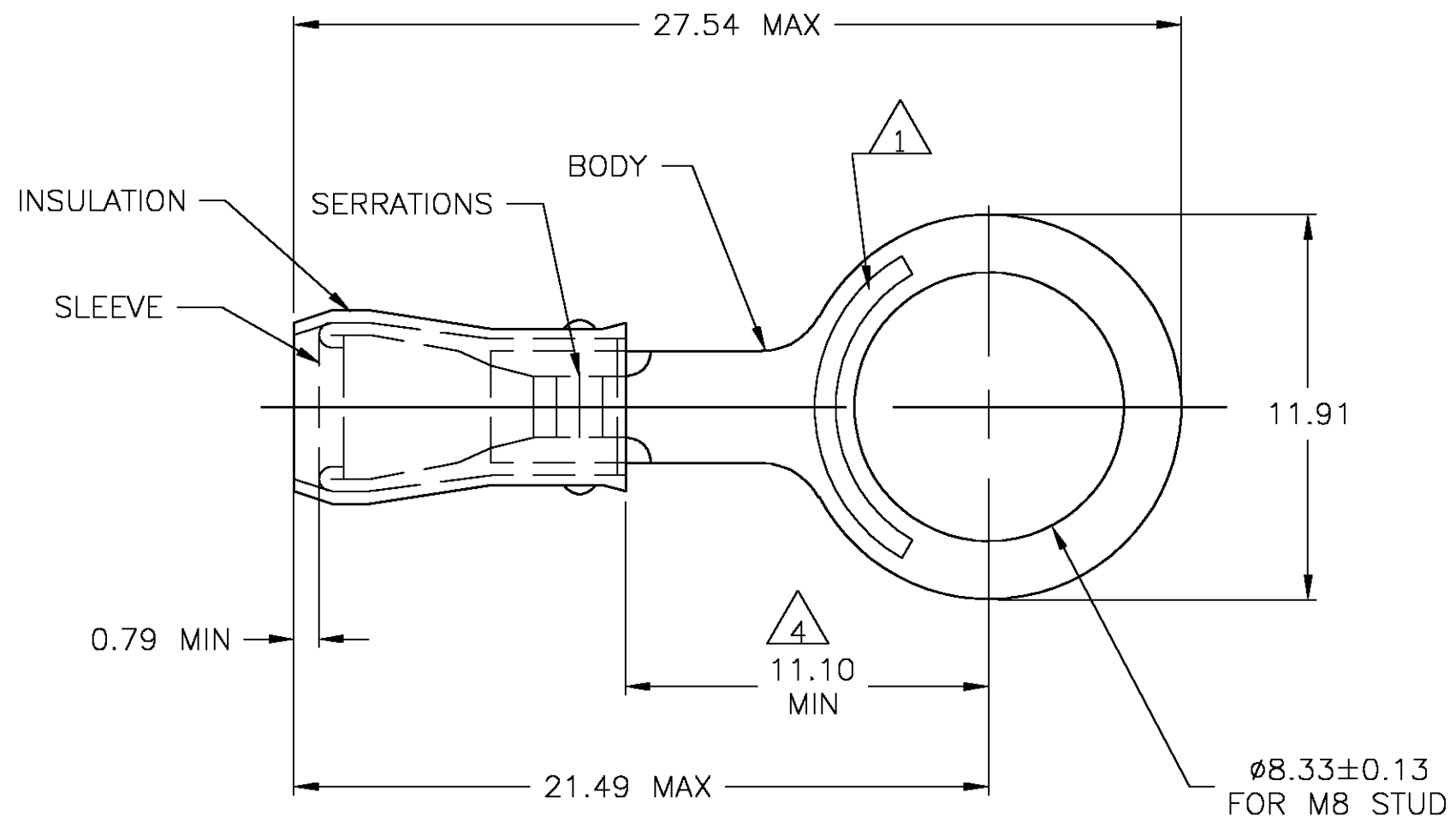

- 1 STAMP AMP 22-18\*, LOCATED APPROX AS SHOWN. STAMPING MAY BE ON TOP OR BOTTOM.
- 2 WIRE INSULATION DIA: 2.67-3.56
- 3 TONGUE MATERIAL THK: 0.84 MAX
- 4 FROM THE EDGE OF METAL WIRE BBL TO CENTER OF STUD HOLE.
- 5 105°C [221°F] MAX OPERATING TEMP.
- 6 VOLTAGE RATING, 300V MAX
- 7 MATERIAL: BODY- COPPER ASTM B-152 SLEEVE: NYLON, RED
- 8 FINISH: BODY- TIN PLATE PER ASTM B545

LOOSE PIECE	150300-0
PACKAGE TYPE	PART NO

THIS DRAWING IS A CONTROLLED DOCUMENT.		DWN JR RUTH 05MAR2004	Tyco Electronics Corporation Harrisburg, Pa 17105-3608	
DIMENSIONS: mm		CHK T MICHELUTTI 05MAR04		
TOLERANCES UNLESS OTHERWISE SPECIFIED:		APVD T MICHELUTTI 05MAR04	NAME TERMINAL, RING TONGUE, P.I.D.G., WIRE SIZE 22-16 AWG	
0 PLC ± - 1 PLC ± - 2 PLC ± .02 3 PLC ± - 4 PLC ± - ANGLES ± -		PRODUCT SPEC -	SIZE A3	
MATERIAL -7		APPLICATION SPEC -	CAGE CODE 00779	DRAWING NO C-150300
FINISH -8		WEIGHT -	RESTRICTED TO -	
CUSTOMER DRAWING			SCALE 5:1	SHEET 1 OF 1
			REV A	