

| | | |
|-----------------|------|-----------|
| PART NUMBER | PACK | HOOD SIZE |
| 8655AZETIAI1KLF | KIT | 09 |

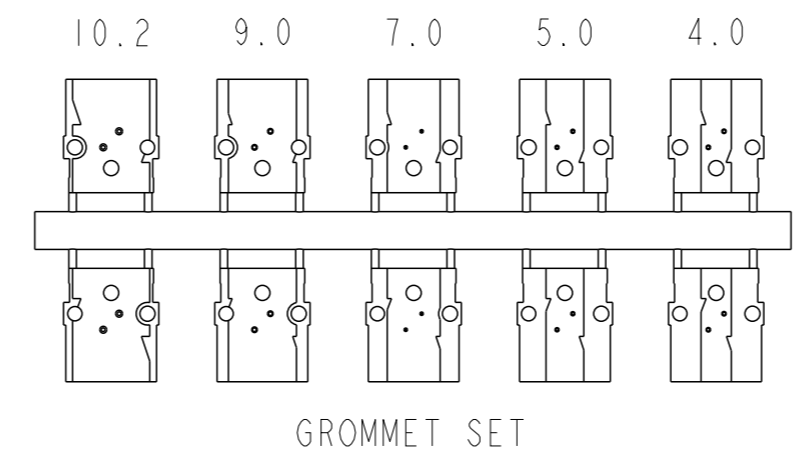
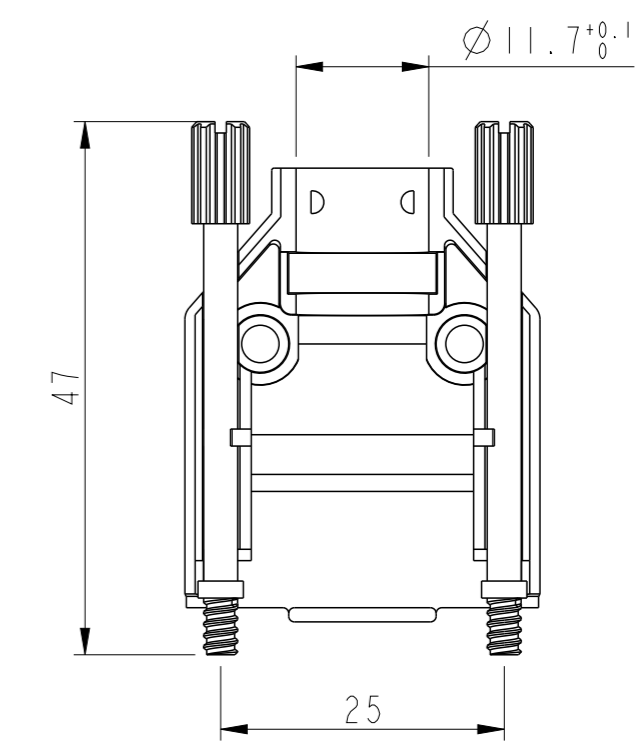
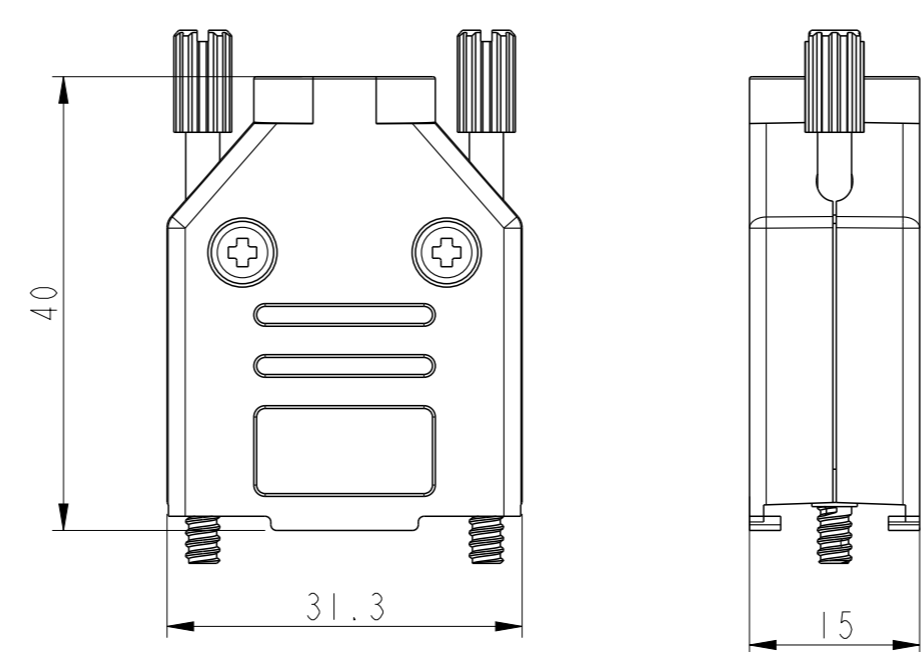
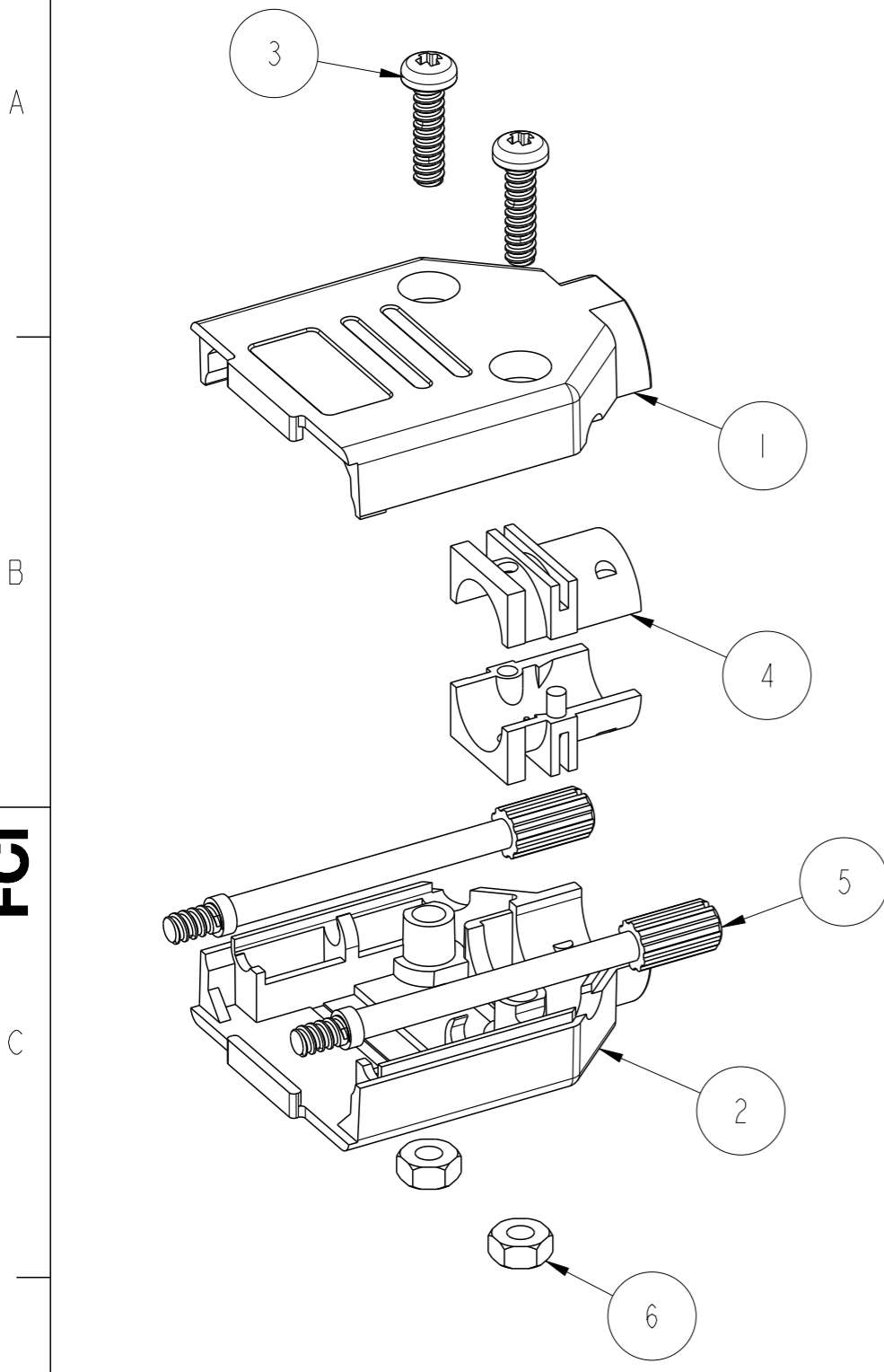

NOTES: (FOR EVERY SIZES)
 1- OPERATING TEMPERATURE: -40°C TO +120°C
 2- INDIVIDUAL KITS SEALED IN PLASTIC COVER IN UNASSEMBLED FORM.
 BOM AS SHOWN IN TABLE

RoHS INFORMATION:
 - THE LF PRODUCT MEETS EUROPEAN UNION DIRECTIVES AND OTHER COUNTRY REGULATIONS AS DESCRIBED IN GS+22-009
 - THE PRODUCT IS NOT INTENDED TO BE EXPOSED TO A MANUFACTURING SOLDER PROCESS

| ITEM NO. | QTY. | PART DESCRIPTION |
|----------|------|-----------------------|
| 1 | 1 | DTPK09-UPPER COVER |
| 2 | 1 | DTPK09-LOWER COVER |
| 3 | 2 | M3X11.5 SCREW |
| 4 | 1 | D45ZK-D2 GROMMET SET |
| 5 | 2 | UNC 4-40X47 JACKSCREW |
| 6 | 2 | M3 NUT |

| | | | | | | | | | | | |
|---------------------------------------|---------------------|------|----------------|------------|---------------------|------------------------|----------------|---------------------|-----------|--------------|---|
| spec ref | - | dr | Dipu Joseph | 2020/09/18 | projection | mm | size | A3 | scale | 3:2 | |
| tolerance std | ISO 406 ISO 1101 | eng | Detouillon, Da | 2020/11/17 | | | ecn no | - | rel level | Released | |
| TOLERANCES UNLESS OTHERWISE SPECIFIED | | chr | - | - | | | product family | - | rel level | Released | |
| surface | linear | appr | Wollin, Severi | 2020/11/13 | Amphenol FCI | | title | DSUB METALIZED HOOD | | rev | A |
| ISO 1302 | angular | 0° | ±2° | cat. no. | - | Product - Customer Drw | dwg no | 8655AZxxIAI1KLF | | sheet 1 of 4 | |

© 2016 AFCI Amphenol FCI

| | | |
|-----------------|------|-----------|
| PART NUMBER | PACK | HOOD SIZE |
| 8655AZATIAI1KLF | KIT | 15 |

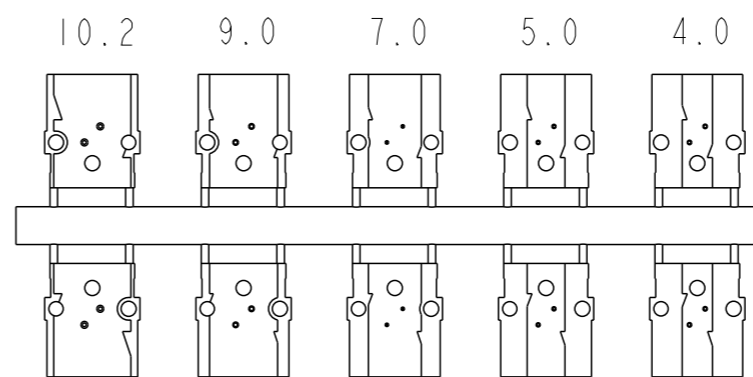
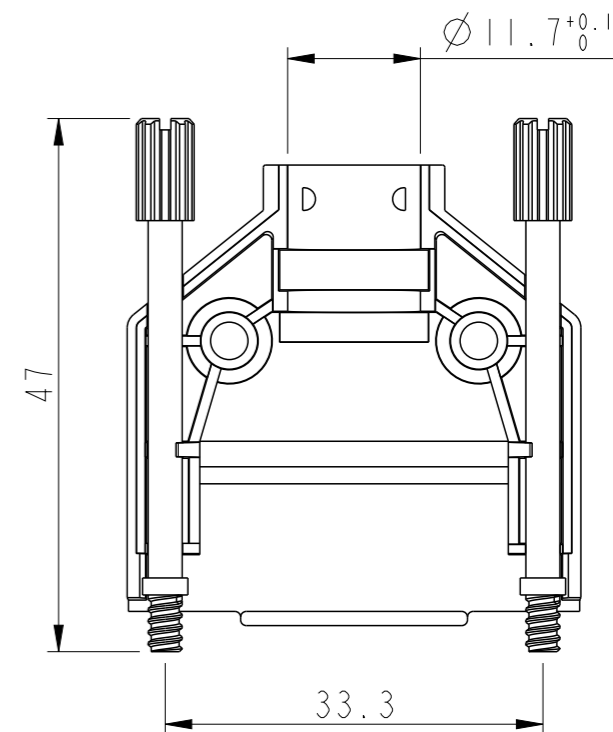
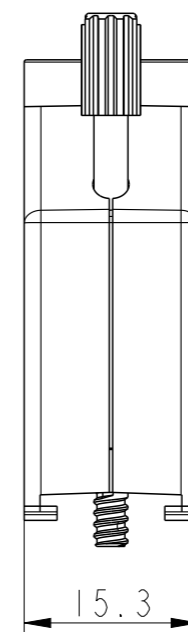
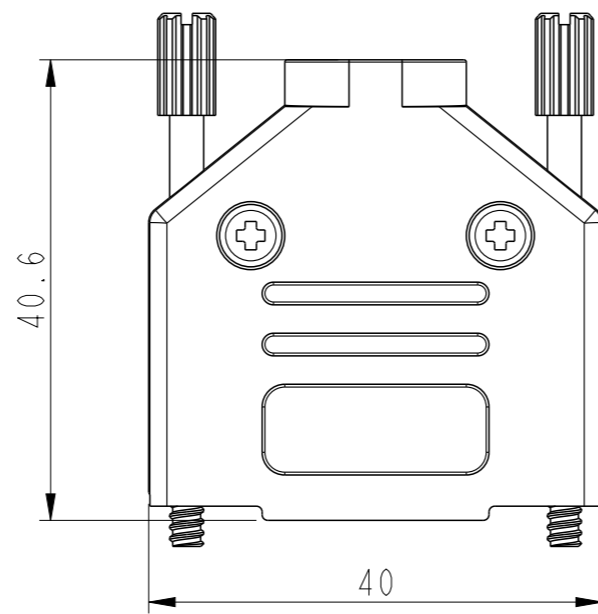
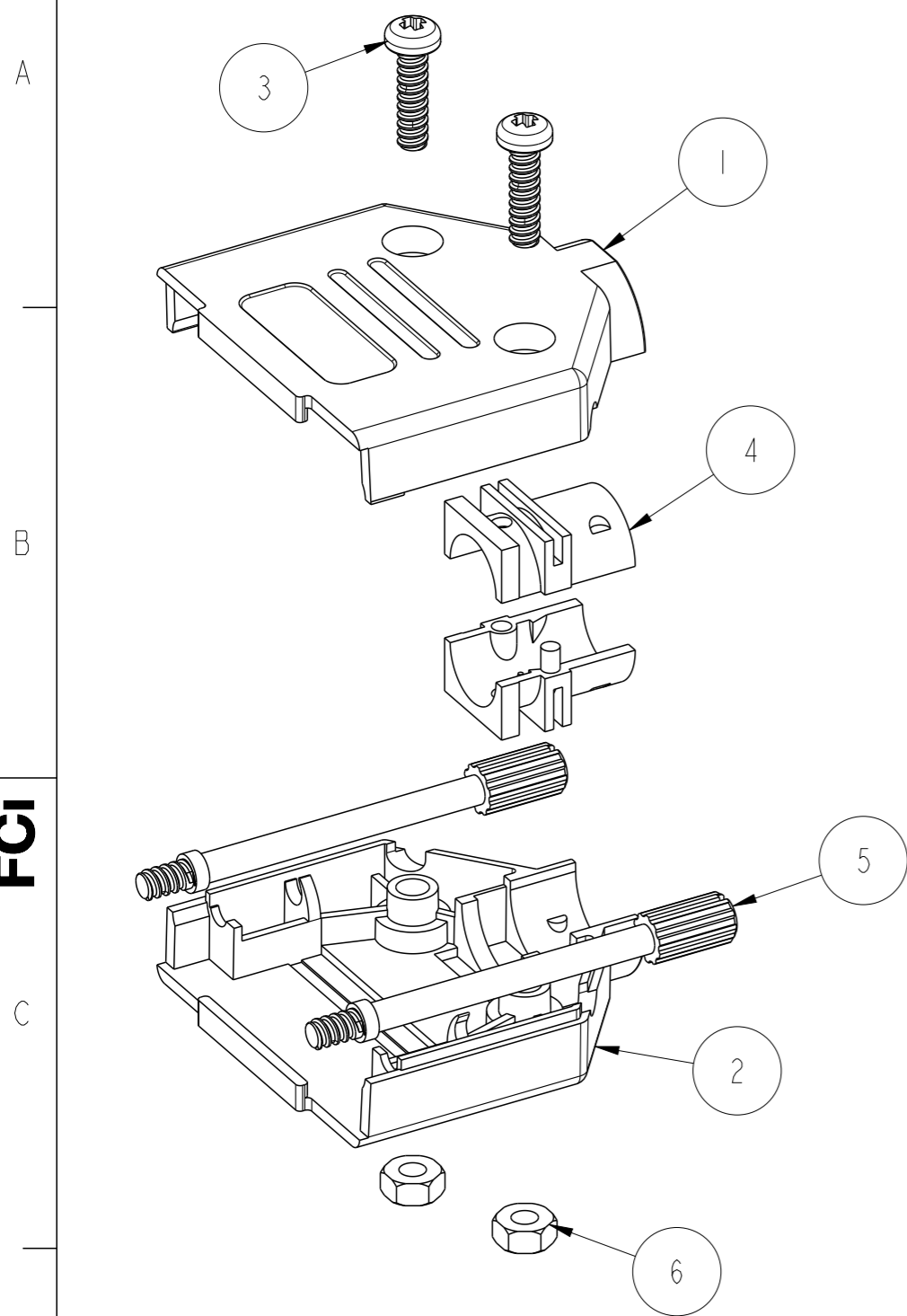

GROMMET SET

| ITEM NO. | QTY. | PART DESCRIPTION |
|----------|------|-----------------------|
| 1 | 1 | DTPK15-UPPER COVER |
| 2 | 1 | DTPK15-LOWER COVER |
| 3 | 2 | M3X11.5 SCREW |
| 4 | 1 | D45ZK-D2 GROMMET SET |
| 5 | 2 | UNC 4-40X47 JACKSCREW |
| 6 | 2 | M3 NUT |

| | | | | | | | | | | |
|---------------------------------------|---------------------|------|----------------|---------------------|----------------------------|----|---------------------------|----------|-----------------------------------|----------|
| spec ref | - | dr | Dipu Joseph | 2020/09/18 | projection | mm | size | A3 | scale | 3:2 |
| tolerance std | ISO 406 ISO 1101 | eng | Detouillon, Da | 2020/11/17 | | | ecn no | - | rel level | Released |
| TOLERANCES UNLESS OTHERWISE SPECIFIED | | chr | - | 2020/11/13 | | | | | | |
| surface | linear | 0.X | ±0.3 | Amphenol FCI | DSUB METALIZED HOOD | | dwg no 8655AZxxIAI1KLF | rev A | cat. no. - Product - Customer Drw | |
| | | 0.XX | ±0.10 | | sheet 2 of 4 | | | | | |
| | angular | 0° | ±2° | | | | | | | |

| | | |
|-----------------|------|-----------|
| PART NUMBER | PACK | HOOD SIZE |
| 8655AZBTIAI1KLF | KIT | 25 |

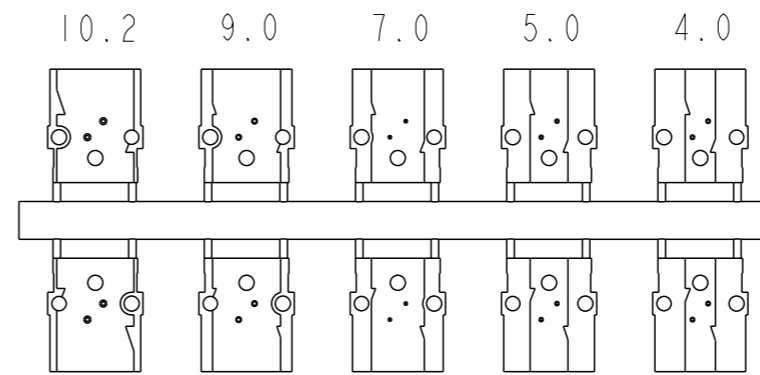
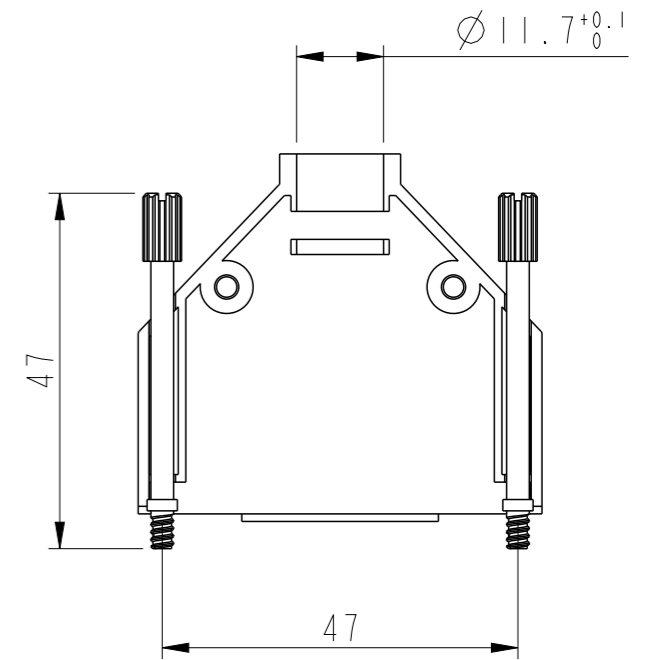
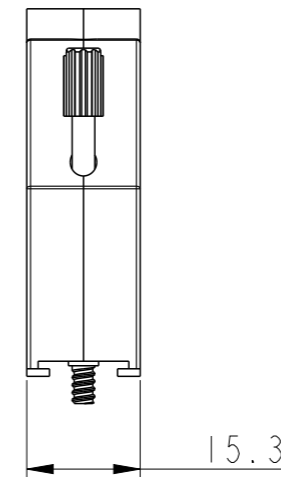
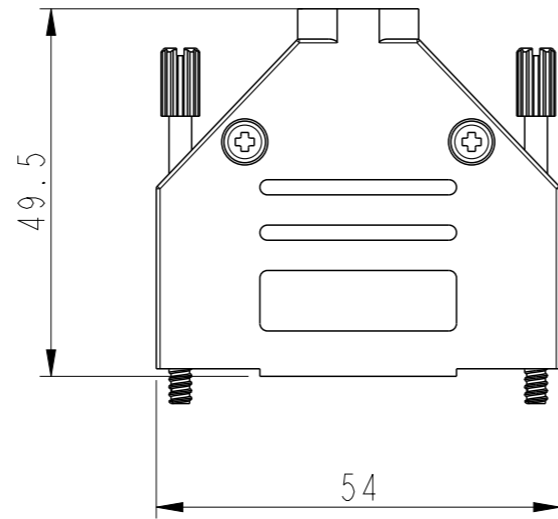
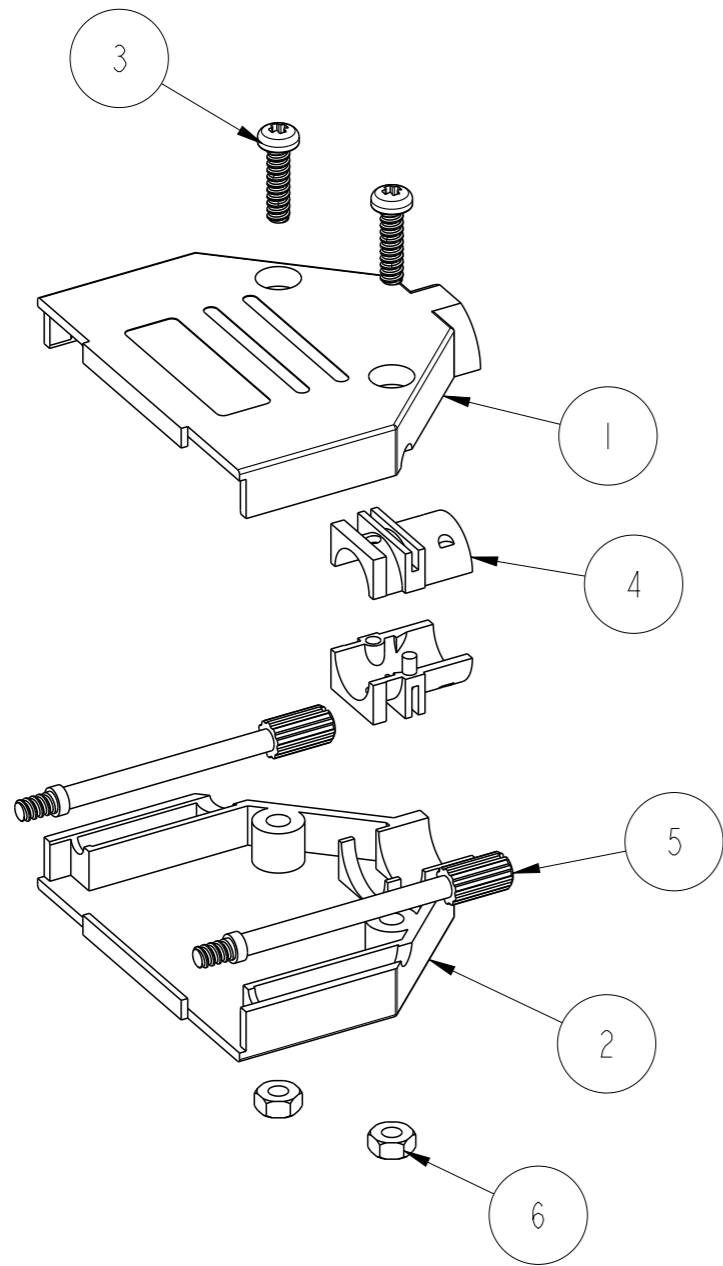

GROMMET SET

| ITEM NO. | QTY. | PART DESCRIPTION |
|----------|------|-----------------------|
| 1 | 1 | DTPK25-UPPER COVER |
| 2 | 1 | DTPK25-LOWER COVER |
| 3 | 2 | M3X11.5 SCREW |
| 4 | 1 | D45ZK-D2 GROMMET SET |
| 5 | 2 | UNC 4-40X47 JACKSCREW |
| 6 | 2 | M3 NUT |

| | | | | | | | | | | |
|---------------------------------------|---------------------|------|----------------|--------------|----------------|---------------------|----------|-----------------|------------------------|--------------|
| spec ref | - | dr | Dipu Joseph | 2020/09/18 | projection | mm | size | A3 | scale | 1:1 |
| tolerance std | ISO 406 ISO 1101 | eng | Detouillon, Da | 2020/11/17 | | | ecn no | - | rel level | Released |
| TOLERANCES UNLESS OTHERWISE SPECIFIED | | chr | - | - | | | | | | |
| surface | linear | appr | Wollin, Severi | 2020/11/13 | product family | - | dwg no | 8655AZxxIAI1KLF | rev | A |
| ISO 1302 | angular | 0° | ±2° | Amphenol FCI | | DSUB METALIZED HOOD | cat. no. | - | Product - Customer Drw | sheet 3 of 4 |

| | | |
|-----------------|------|-----------|
| PART NUMBER | PACK | HOOD SIZE |
| 8655AZCTIAI1KLF | KIT | 37 |

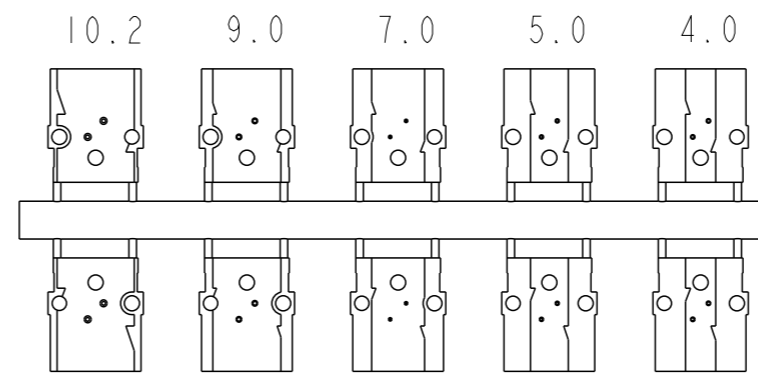
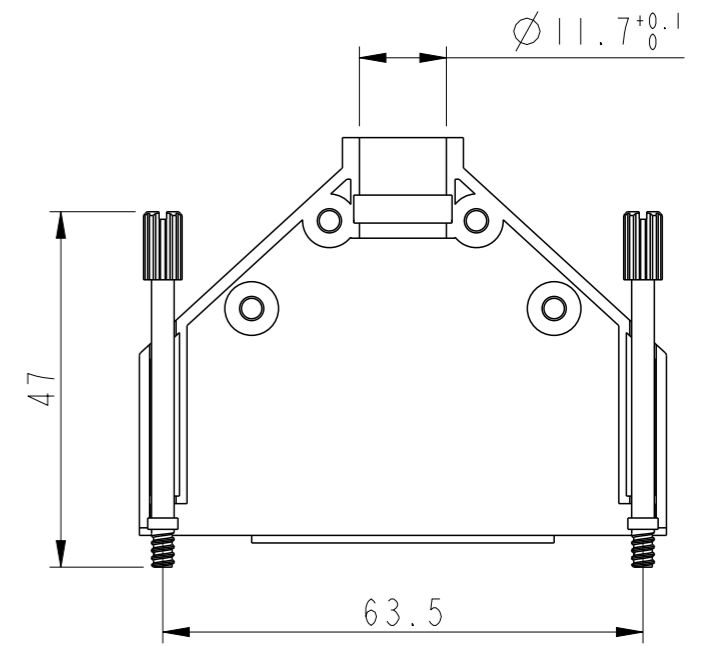
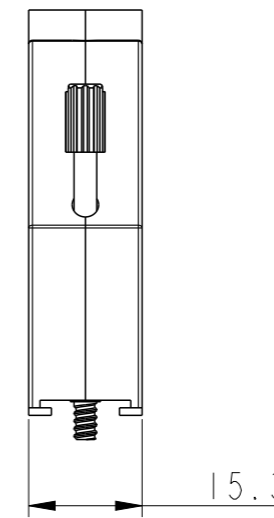
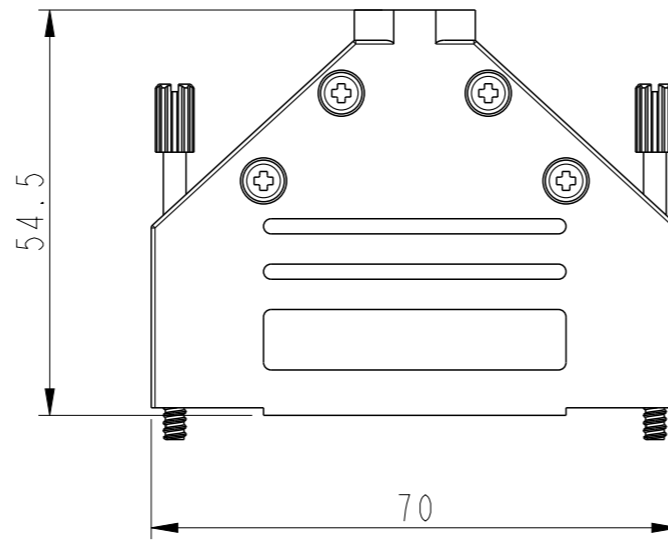
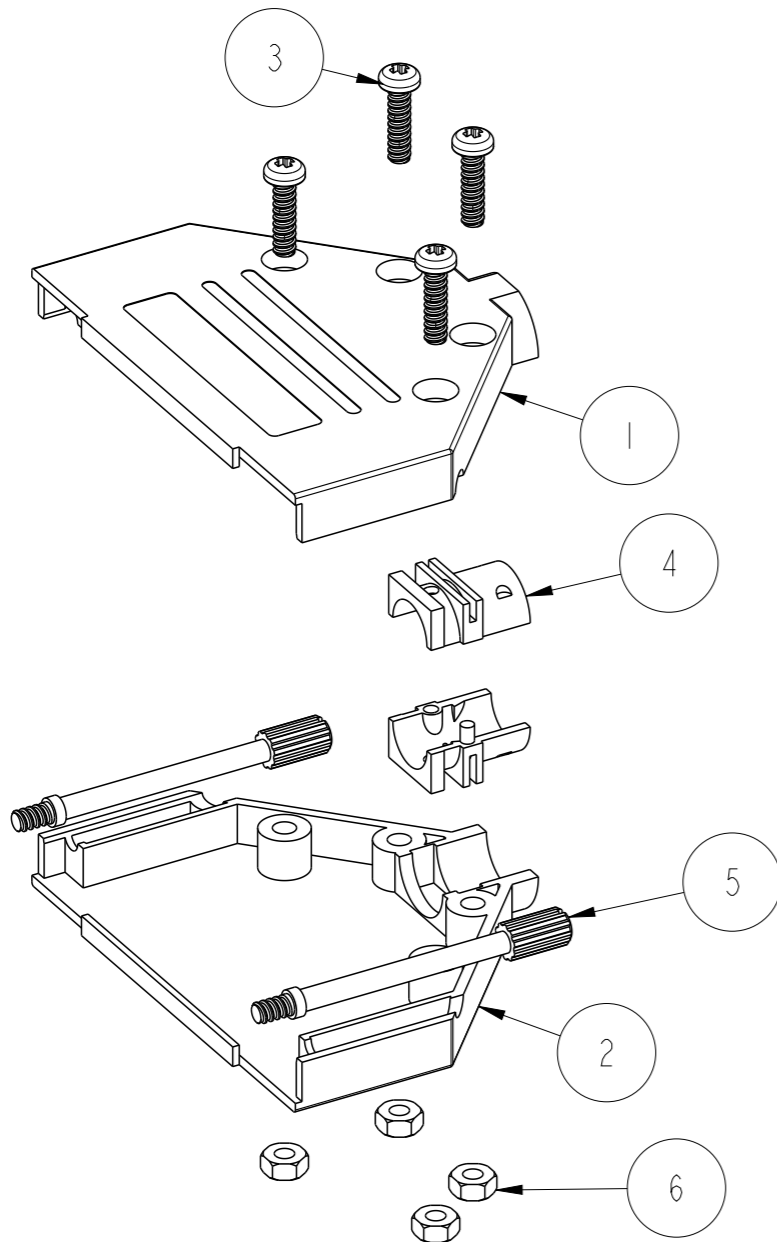

GROMMET SET

| ITEM NO. | QTY. | PART DESCRIPTION |
|----------|------|-----------------------|
| 1 | 1 | DTPK37-UPPER COVER |
| 2 | 1 | DTPK37-LOWER COVER |
| 3 | 4 | M3X11.5 SCREW |
| 4 | 1 | D45ZK-D2 GROMMET SET |
| 5 | 2 | UNC 4-40X47 JACKSCREW |
| 6 | 4 | M3 NUT |

| | | | | | | | | | | | | | | | | | | | | | | | | | | | |
|---------------------------------------|---------------------|---|----------------|------------------------|----------------|--------------|-----------|----------|---------------------|----------|--------|---|--|-----|------|------|-------|-------|--------|---------|--------|---------------------|--|---------------------|--|---------------------------|----------|
| spec ref | - | dr | Dipu Joseph | 2020/09/18 | projection | mm | size | A3 | scale | 1:1 | | | | | | | | | | | | | | | | | |
| tolerance std | ISO 406 ISO 1101 | eng | Detouillon, Da | 2020/11/17 | | | ecn no | - | rel level | Released | | | | | | | | | | | | | | | | | |
| TOLERANCES UNLESS OTHERWISE SPECIFIED | | chr | - | - | | | | | | | | | | | | | | | | | | | | | | | |
| surface | ISO 1302 | appr | Wollin, Severi | 2020/11/13 | product family | - | rel level | Released | Amphenol FCI | | | | | | | | | | | | | | | | | | |
| | linear | <table border="1"> <tr><td>0.X</td><td>±0.3</td></tr> <tr><td>0.XX</td><td>±0.10</td></tr> <tr><td>0.XXX</td><td>±0.005</td></tr> <tr><td>angular</td><td>0° ±2°</td></tr> </table> | | 0.X | ±0.3 | 0.XX | ±0.10 | 0.XXX | ±0.005 | angular | 0° ±2° | <table border="1"> <tr><td>0.X</td><td>±0.3</td></tr> <tr><td>0.XX</td><td>±0.10</td></tr> <tr><td>0.XXX</td><td>±0.005</td></tr> <tr><td>angular</td><td>0° ±2°</td></tr> </table> | | 0.X | ±0.3 | 0.XX | ±0.10 | 0.XXX | ±0.005 | angular | 0° ±2° | Amphenol FCI | | DSUB METALIZED HOOD | | dwg no 8655AZxxIAI1KLF | rev A |
| 0.X | ±0.3 | | | | | | | | | | | | | | | | | | | | | | | | | | |
| 0.XX | ±0.10 | | | | | | | | | | | | | | | | | | | | | | | | | | |
| 0.XXX | ±0.005 | | | | | | | | | | | | | | | | | | | | | | | | | | |
| angular | 0° ±2° | | | | | | | | | | | | | | | | | | | | | | | | | | |
| 0.X | ±0.3 | | | | | | | | | | | | | | | | | | | | | | | | | | |
| 0.XX | ±0.10 | | | | | | | | | | | | | | | | | | | | | | | | | | |
| 0.XXX | ±0.005 | | | | | | | | | | | | | | | | | | | | | | | | | | |
| angular | 0° ±2° | | | | | | | | | | | | | | | | | | | | | | | | | | |
| cat. no. | | - | | Product - Customer Drw | | sheet 4 of 4 | | | | | | | | | | | | | | | | | | | | | |