



Electrical specifications

Center Frequency: 1650 MHz
1.5 dB BW: 20 MHz min
Insertion loss in PB: 2.5 DB max
Return loss: 15 dB min
Rejection 1: 45 dBc@ 1635 MHz
Rejection 2: 70 dBc@ 1665 MHz

Mechanical

Mounting Method: Threaded Mounting Holes
Connector Type: SMA Female
Dimensions: 6.46 X 3.31 X 2.25 in

Environmental

Operating Temperature: -45 to +85° C
Storage Temperature: -55 to +95° C
Shock: 20 G. 11ms
Vibration: 20 G. 5 to 200 Hz

Outline Drawing:

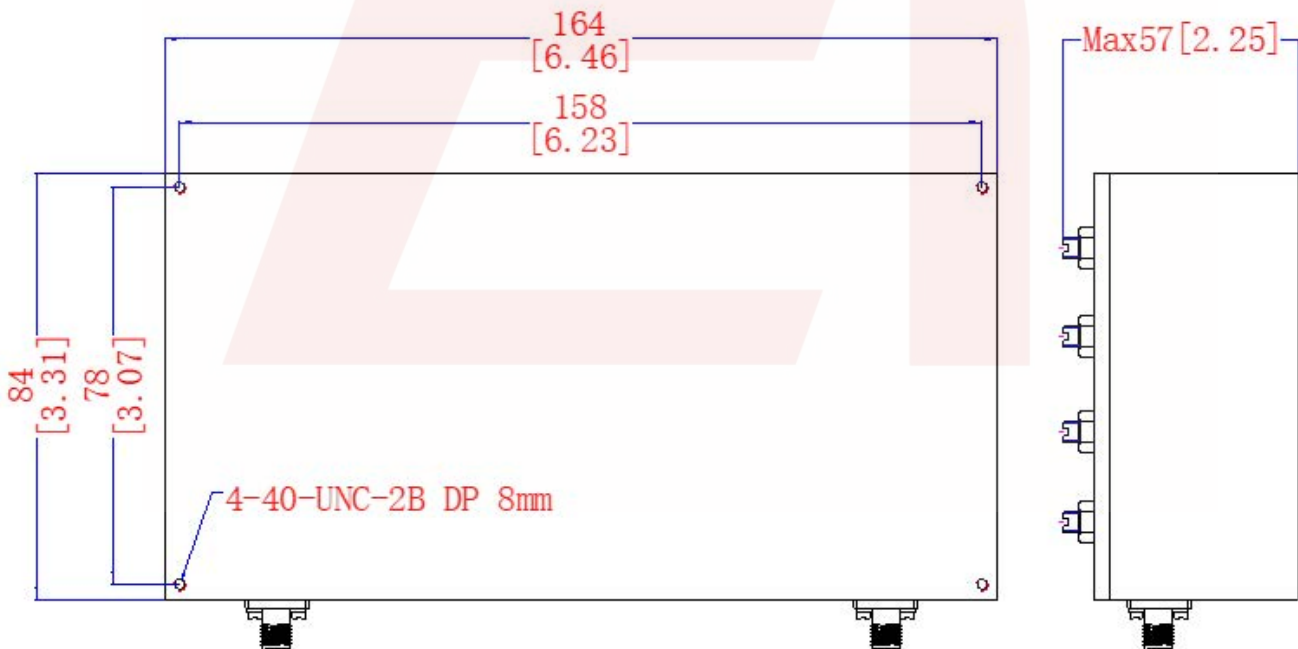



1650 MHz Cavity Bandpass Filter

Part Number: AB1650B518



Plot:

