

AVIX

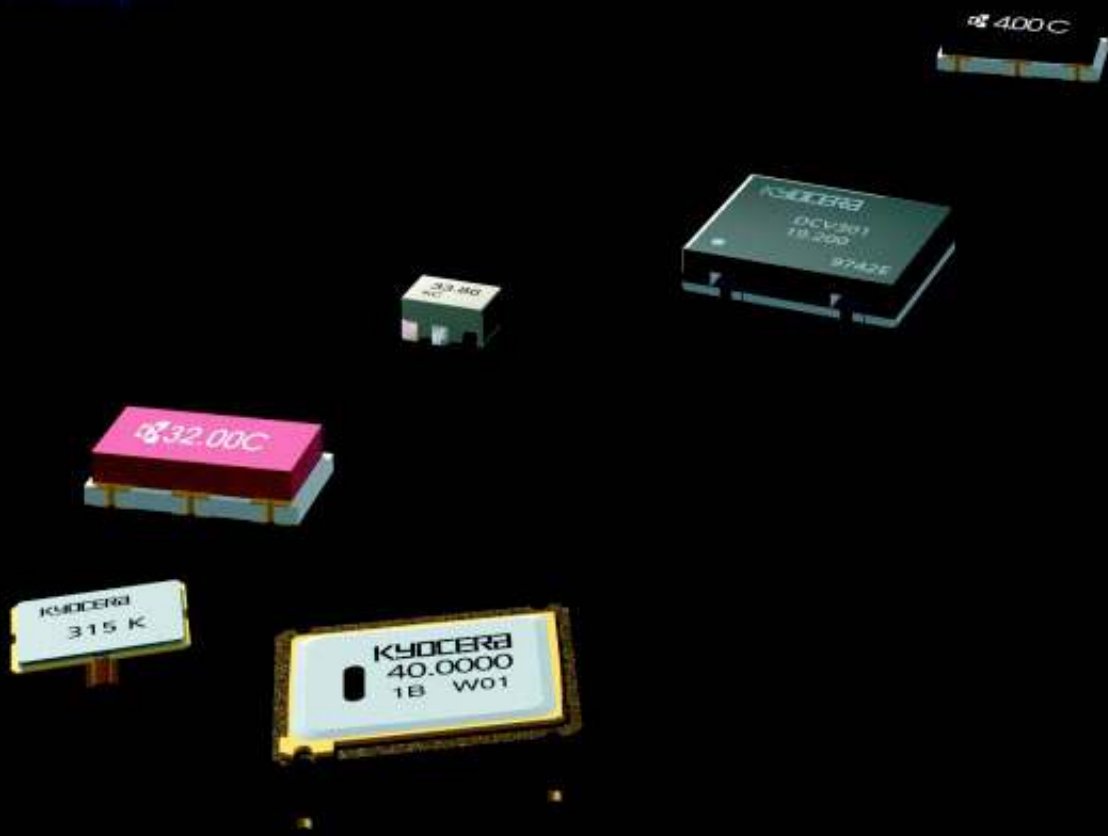

**KYOCERA
Timing Devices**

Resonators

Crystals

Oscillators

Table of Contents

CERAMIC RESONATORS

| | |
|---|-------|
| General Description | 2-7 |
| KBR -Y Series - Surface Mountable — f_0 : 380 to 1050 kHz | 8-9 |
| KBR -B, -BK, -F Series — f_0 : 190 to 1050 kHz | 10-11 |
| KBR Special Series | 12 |
| PBRC -A Series - Surface Mountable — f_0 : 2.00 to 8.00 MHz | 13 |
| PBRC -B/D Series - Surface Mountable — f_0 : 2.00 to 36.00 MHz | 14 |
| Tape & Reel Packaging, PBRC-A/B/D | 15 |
| SSR-B Series | 16 |
| KBR -M, -MS, -MSA, -MSB Series — f_0 : 2.00 to 13.00 MHz | 17 |
| KBR -MY, MSA Series — f_0 : 13.01 to 36.00 MHz | 18 |
| KBR -MKC, -MKD, -MKS Series — f_0 : 3.45 to 8.00 MHz and 16.00 to 36.00 MHz | 19 |
| Tape & Reel Packaging, MHz Ceramic Resonators | 20 |

SURFACE ACOUSTIC WAVE RESONATORS

| | |
|--|-------|
| General Description | 21 |
| PAR Series | 22 |
| KAR -CS, -CT, -CB, -CD, -CK Series — f_0 : 46 to 315 MHz | 23-24 |
| KAR Series Data | 25 |

QUARTZ CRYSTALS

| | |
|------------------|----|
| KSX Series | 26 |
| KT Series | 27 |

CLOCK OSCILLATORS

| | |
|--|-------|
| General Description | 28-30 |
| K50 Series — f_0 : 8 to 68 MHz | 31-34 |
| KT11 Series | 35 |
| KT12 Series | 36 |
| KT14 Series | 37 |
| VCO Series | 38-42 |
| KXO-01 Series — f_0 : 8.0 to 50 MHz | 43-44 |
| KXO-HC/KHO-HC Series — f_0 : 1.0 to 80 MHz | 45-46 |
| 386 Series | 47-48 |

Timing Device Product Offering

QUARTZ CRYSTALS, RESONATORS and CLOCK OSCILLATORS

| Product Name | | Type | Oscillating Frequency | | | | | | Applications | |
|-------------------|--------------------|--------|---|-------|--------|-----------------------------|-------|--------|--------------|-------------------------------|
| | | | 1KHz | 10KHz | 100KHz | 1MHz | 10MHz | 100MHz | | 1GHz |
| Quartz Crystal | | Leaded | | | | 12.0M | 22.0M | | | Telecommunication |
| | | SMD | | | | 12.0M | 22.0M | | | Telecommunication |
| Ceramic Resonator | KHz Band | Leaded | 190k ~ 680k 795k ~ 815k | | | 960k ~ 1050k | | | | Micro Processor |
| | | SMD | 380k ~ 430k 440k ~ 525k 600k ~ 655k | | | 795k ~ 815k 960k ~ 1050k | | | | Micro Processor |
| | MHz Band | Leaded | | | 1.92M | 40.0M | | | | Micro Processor |
| | | SMD | | | 2.0M | 60.0M | | | | Micro Processor |
| Saw Resonator | | Leaded | | | | 46M | 479M | | | RF Modulator Keyless Entry |
| | | SMD | | | | 300M | 479M | | | RF Modulator Keyless Entry |
| Clock Oscillator | | Leaded | | 500k | 72M | | | | | Micro Processor |
| | | SMD | | | 8.0M | 68M | | | | Micro Processor |
| | KT 11,12,14 Series | SMD | | | | 12.0M | 20.0M | | | Telecommunication |

VOLTAGE CONTROLLED OSCILLATORS

| Application | | System | Frequency | | | | Application Availability | | | |
|-----------------------|---|--------|-----------|------|--------|------|--------------------------|-----------|-----------|-----------|
| | | | 500MHz | 1GHz | 1.5GHz | 2GHz | VK Series | EK Series | YK Series | RK Series |
| Cordless Phone | JPN | | | | | ● | | | | |
| | CTI CTI+ | | | | | ● | | | | |
| | PHS | | | | | | ● | | | |
| | DECT | | | | | | | | ● | |
| | CT2+ | | | | | | | | ● | |
| Low Power Transmitter | Transceiver LAN Remote Controller Control | | | | | ● | | | | |
| | Wireless Microphone | | | | | | ● | | | |
| Cellular Phone | AMPS | | | | | | ● | | | |
| | TACS | | | | | | ● | | | |
| | NMT | | | | | | ● | | | |
| | NTT | | | | | | ● | | | |
| | PDC | | | | | ● | ● | ● | | |
| | GSM | | | | | | ● | | ● | |
| | US digital | | | | | | ● | | | |
| PCN | | | | | | | ● | ● | | |
| Satellite | GPS | | | | | | ● | | ● | |

AVX/Kyocera Ceramic Resonators

KHz BAND CERAMIC RESONATORS

| Part Series | Frequency Range | Type | Lead Configuration |
|-----------------|-----------------|------------|--|
| KBR-Y | 380 to 1050 kHz | SMT | Gull Wing Surface Mount |
| KBR-B | 190 to 680 kHz | Std Q_m | Standard, Single-in-line, Formed Leads |
| KBR-BK | 380 to 655 kHz | Std Q_m | Standard, Single-in-line |
| KBR-F | 795 to 1050 kHz | High Q_m | Standard, Single-in-line |
| Specials | Per application | — | — |

MHz BAND CERAMIC RESONATORS

| Part Series | Frequency Range* | Type |
|-----------------|-----------------------------------|---|
| PBRC-A | 2.00 to 8.00 MHz | SMT without Capacitor |
| PBRC-B/D | 2.00 to 36.00 MHz | SMT with Built-in Capacitor |
| SSR-B | 16.00 to 60.00 MHz | Ultraminiature SMT with Built-in Capacitor |
| KBR-MS | 2.00 to 3.57 MHz | Standard |
| KBR-MSA | 3.58 to 8.00 MHz | Water resistant |
| KBR-MSB | 3.58 to 6.00 MHz | “No-Clean” Process only |
| KBR-M | 6.01 to 13.00 MHz | Standard |
| KBR-MY | 13.01 to 16.00 MHz | CMOS |
| KBR-MSA | 16.00 to 36.00 MHz | High Frequency Standard |
| KBR-MKS | 3.58 to 8.00 MHz | Built-in Capacitor –Low Profile |
| KBR-MKC | 3.58 to 8.00 MHz | Built-in Capacitor -“No-Clean” Process only |
| KBR-MKD | 3.58 to 8.00 MHz, 16.00 to 36 MHz | Built-in Capacitor-Water resistant |

*For additional frequencies consult factory.

GENERAL DESCRIPTION

AVX/Kyocera produces a broad range of high quality ceramic resonators covering both the kilohertz and megahertz frequency ranges. The high quality and extensive coverage of this product line allows optimum design of almost any oscillating circuit.

Ceramic resonators stand between quartz crystal oscillators and LC/RC oscillators in regard to accuracy but are considerably smaller, require no adjustments, have improved start-up times, and are low in cost.

Their oscillation is dependent upon mechanical resonance associated with their piezoelectric crystalline structure. These materials (usually barium titanate or lead-zirconium titanate, PZT) have large dipole movement which causes the distortion or growth of the crystal by an applied

electric field. The resonance frequency depends on the vibration mode as shown in Figure 1.

A basic feedback circuit is shown in Figure 2. It consists of an amplifier with a 180° phase shift and attenuator. A negative polar output (volt) is obtained with an amplitude equal to the gain of the amplifier times the input voltage ($G \times V_{IN}$). After the signal goes through the feedback network with an attenuation ratio of β , a negative polar wave equal to $\beta \times (G \times V_{IN})$ is fed back to the input. If this feedback is greater than the initial input voltage (V_{IN}), oscillation will occur. This satisfies the two conditions necessary for oscillation:

1. $G \times \beta > 1$
2. Phase cycle around the loop is an integral multiple of 360°.

| Table I Oscillators and Resonator Frequency Application | | Table II Timing Devices | | | | | | | | | | | |
|--|--------|----------------------------|-----------------------------|------------------|------|------|----|----|-----|-----|------|------|----|
| | | (Hz) | 10k | 20k | 100k | 200k | 1M | 2M | 10M | 20M | 100M | 200M | 1G |
| Ceramic Resonators 190 kHz ~ 60 MHz | | | | | | | | | | | | | |
| SAW Resonators 46 MHz ~ 315 MHz | | | | | | | | | | | | | |
| Oscillators 1 MHz ~ 2 GHz | | | | | | | | | | | | | |
| Quartz Crystals 12 MHz ~ 22 MHz | | | | | | | | | | | | | |
| Type | Symbol | Frequency Tolerance | Typical Frequency Stability | Relative Size | Cost | | | | | | | | |
| LC | | ±2% | ±500ppm/°C | Largest | Low | | | | | | | | |
| RC | | ±1% | ±100ppm/°C | Smallest | Low | | | | | | | | |
| Ceramic Resonator | | ±0.5% | ±50ppm/°C | Next to Smallest | Low | | | | | | | | |
| Quartz Crystal | | ±0.002% | ±1ppm/°C | Next to Largest | High | | | | | | | | |

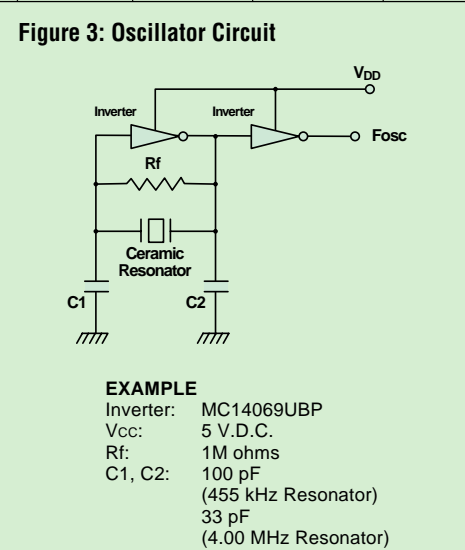
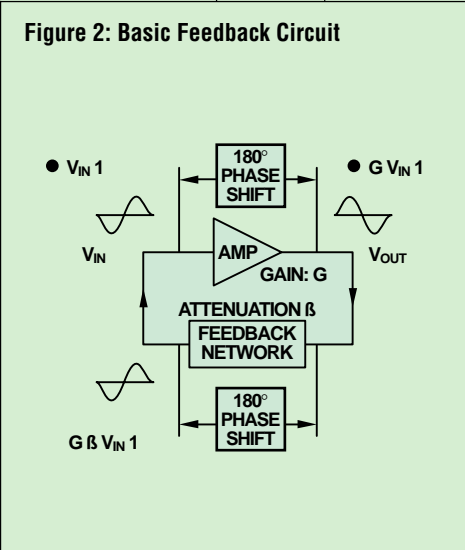
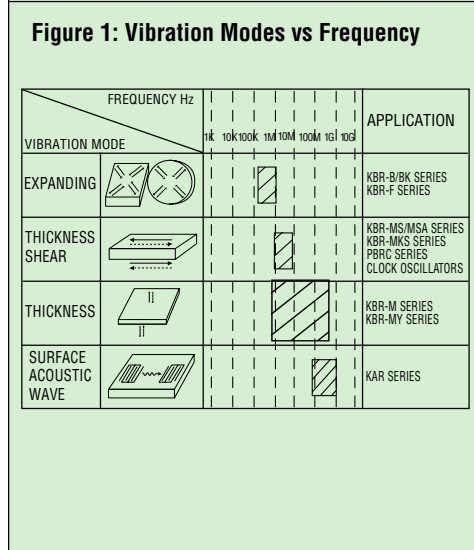

AVX/Kyocera Ceramic Resonators

GENERAL DESCRIPTION continued

The mechanical vibration of a ceramic resonator can be represented by an equivalent electrical circuit consisting of L, C, and R's (Figure 4). The impedance and phase curves of a ceramic resonator are shown in Figure 5.

Between the resonant frequency (f_r) and the anti-resonant frequency (f_a), the ceramic resonator acts like an inductor with performance identical to a coil and a resistor (Figure 4-B). At other frequencies, it has capacitive characteristics (Figure 4-A).

The equivalent circuit parameters can be determined from the resonant and anti-resonant frequencies. These equations are shown in Table III with the equivalent circuit parameters of typical AVX/Kyocera resonators shown in Table IV.

Ceramic resonators have much lower Q_m and higher equivalent capacitances than crystal oscillators. Oscillation circuits of various I.C.'s can be either low (inverter) or high (Schmidt) gain.

**Figure 4:
Electrical Equivalent Circuit**

A. $f = f_r$

B. $f_r \leq f \leq f_a$

**Figure 5:
Impedance and Phase Charts**

Table III: Equivalent Circuit Equations

$$f_r = \frac{1}{2\pi\sqrt{L_0 C_0}}$$

$$L_0 = \frac{1}{4\pi^2 f_r^2 C \left[1 - \left(\frac{f_r}{f_a}\right)^2\right]}$$

$$f_a = \frac{1}{2\pi\sqrt{L_0 C_0 C_1 / (C_0 + C_1)}}$$

$$C_0 = C \left[1 - \left(\frac{f_r}{f_a}\right)^2\right]$$

where $C = C_0 + C_1$

$$f_a = f_r \sqrt{1 + \left(\frac{C_0}{C_1}\right)}$$

$$Q_m = \frac{1}{2\pi f_r R_0 C}$$

$$Q_m = \frac{1}{2\pi f_r R_0 C \left[1 - \left(\frac{f_r}{f_a}\right)^2\right]}$$

Table IV: Typical Parameters of the Equivalent Circuit

| | KBR-4.00MSA/MSB | KBR-455(BK) |
|-------|-----------------|-------------|
| R_0 | 8Ω | 6Ω |
| L_0 | 318μH | 3.2mH |
| C_0 | 5.4pF | 43pF |
| C_1 | 42pF | 360pF |
| Q_M | 970 | 1600 |

APPLICATION AND TEST CIRCUITS

In some circuits, a feedback resistor (R_f , Figure 1) is required to allow oscillation to start when the power is initially applied. Its value is generally 1 M Ω in ceramic resonator circuits.

Special attention should be paid to the design of oscillator circuits, because they have a significant impact on the performance of the system. To determine proper circuit parameters, careful consideration must be given

to each component's characteristics under normal and marginal working conditions. Recommended component values for various IC's and microprocessors are given in the Appendix "Application Circuits for Ceramic Resonators." These values should be checked in the actual operating circuit to confirm their performance over changing conditions of input voltage and temperature.

Figure 1:
CMOS Clock Generator 480kHz

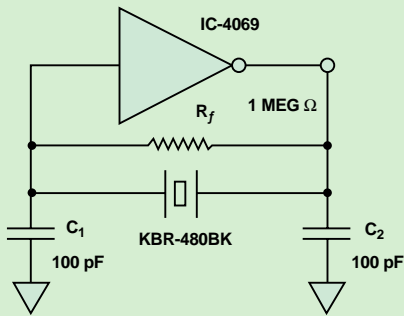

Figure 2:
Low Power Schottky

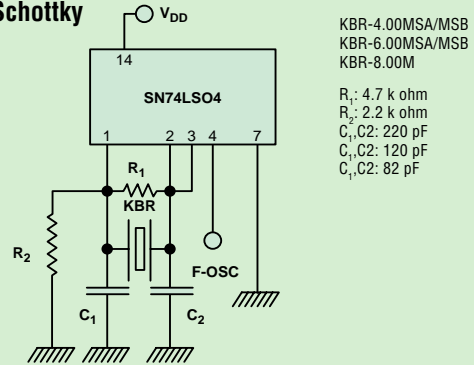

Figure 3:
4 Bit Microprocessor Clock

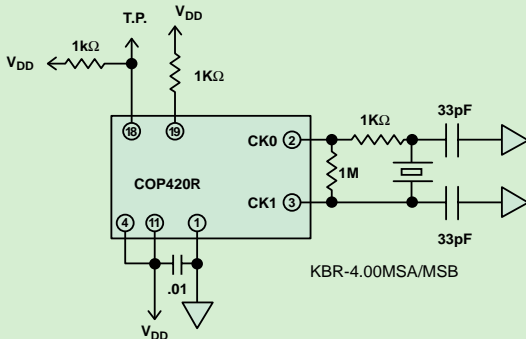

Figure 4:
Test Circuit Spurious Response

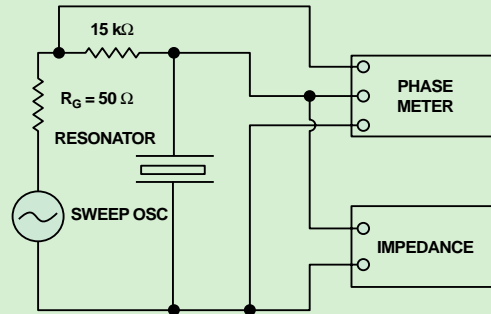
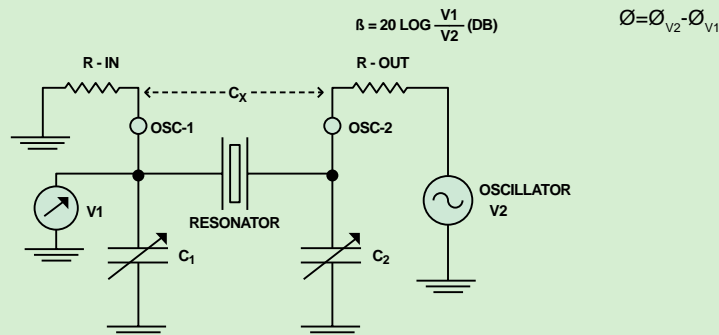

Figure 5:
Simulation Circuit



APPLICATION AND TEST CIRCUITS continued

The design of an oscillation circuit requires an accurate choice of circuit components to ensure oscillation within the specific voltage range of the IC (Figure 6). Semiconductor manufacturers' data books categorize V_H and V_L for both input and output requirements. The next stage of a design can be driven from either the IC input or output. Special attention should be paid to V_{IH} and V_{IL} or V_{OH} and V_{OL} depending upon where the next stage comes from the IC.

Oscillation frequency and amplitude depend upon the values of the external load capacitors (C_1 , C_2). These

effects are illustrated in Figures 7, 8 and 9. When the feedback ratio and the input oscillation amplitude are decreased too far, the circuit becomes vulnerable to external noise and might oscillate spuriously with the external noise.

There are some cases when a high gain IC or one with a wide non-linear range will give abnormal oscillation from sub-vibration of the resonator. This can be prevented by adding a damping resistor to decrease the feedback ratio or by increasing the load capacitance values. The spurious characteristics of typical AVX/Kyocera kHz and MHz resonators are shown in Figures 10 and 11.

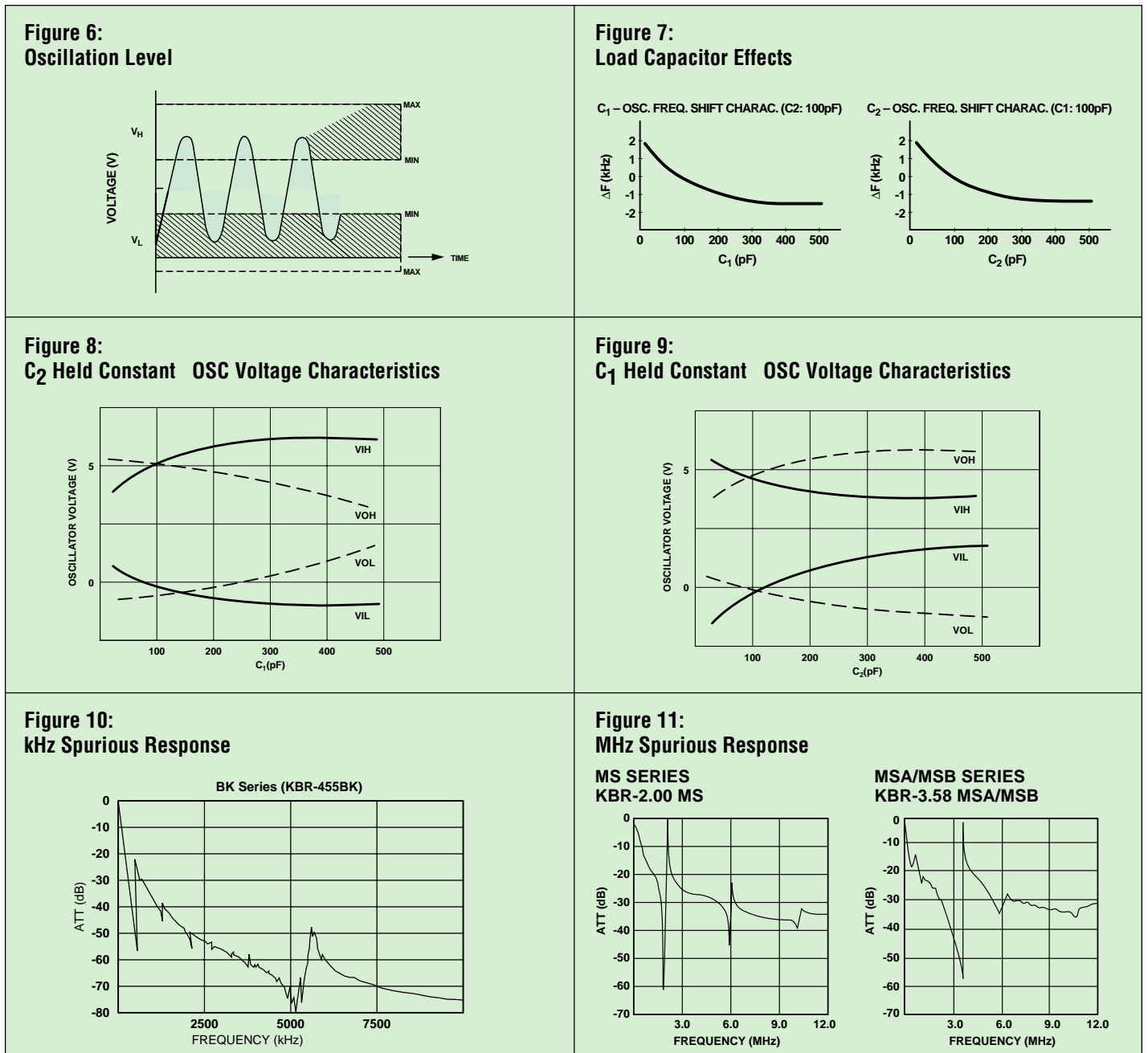

KBR -Y Series Surface Mountable Ceramic Resonators

kHz Band SMT Formed Leads Ceramic Resonators

f_0 : 380 to 1050 kHz

FEATURES

- 1) Reflow solderable
- 2) Washable
- 3) Surface mountable
- 4) 1000 pcs. per reel
- 5) Sold in increments of 2000 pcs.

HOW TO ORDER

KBR - 455 Y TR

- ① Type: (Kyocera Bulk Resonator)
- ② Oscillation frequency: 380 to 1050 kHz
- ③ Resonator type: Y = Surface mountable
- ④ Packaging: TR = Tape and reel



STRUCTURE

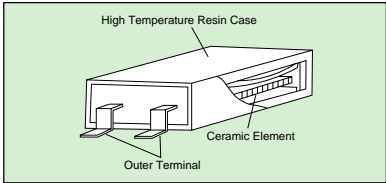

SPECIFICATIONS (KBR-□ Y)

| Parameters | Fig. A | | Fig. B | | Fig. C | |
|--|----------------|----------------------------|------------------|----------------|-----------------|--|
| | 380 to 430 kHz | 440 to 525 kHz | 600 to 655 kHz | 795 to 815 kHz | 960 to 1020 kHz | |
| Frequency Range | 380 to 430 kHz | 440 to 525 kHz | 600 to 655 kHz | 795 to 815 kHz | 960 to 1020 kHz | |
| Frequency Tolerance | ±0.5% | ±0.5% | ±0.5% | ±0.5% | ±0.5% | |
| Resonant Impedance | 20 Max | 20 Max | 50 Max | 70 Max | 100 Max | |
| Anti-resonant Impedance | 30k Min | 35k Min | 50k Min | 70k Min | 70k Min | |
| Temperature Characteristics (-20 to +80°C) | ±0.3% | ±0.3% | ±0.3% | ±0.3% | ±0.3% | |
| C ₁ | 100pF | 100pF | 100pF | 100pF | 100pF | |
| C ₂ | 470pF | 100pF | 100pF | 100pF | 100pF | |
| Standard Oscillation Frequency | 400kHz | 455kHz 480kHz 500kHz | 600kHz 640kHz | 800kHz | 1000kHz | |

DIMENSIONS

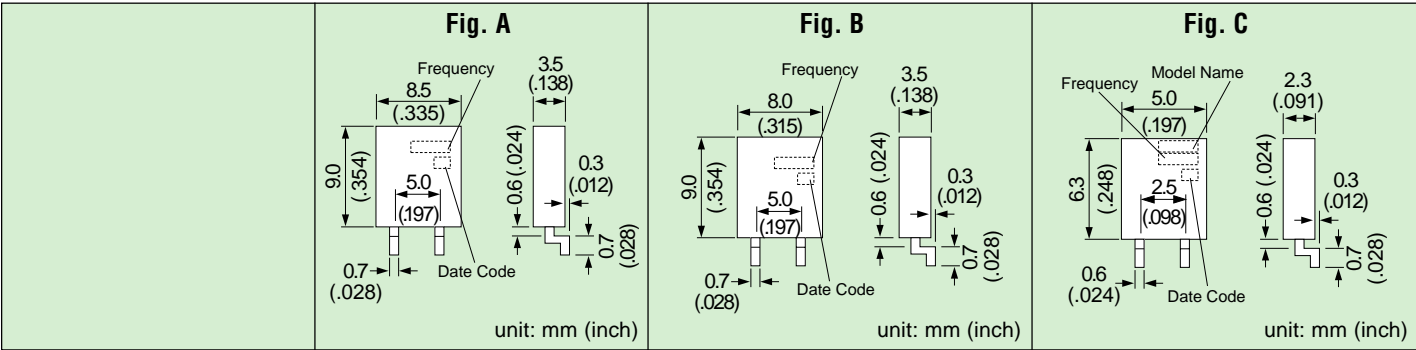

KBR -Y Series Surface Mountable Ceramic Resonators

kHz Band SMT Formed Leads Ceramic Resonators f_o : 380 to 1050 kHz

TEST CIRCUIT

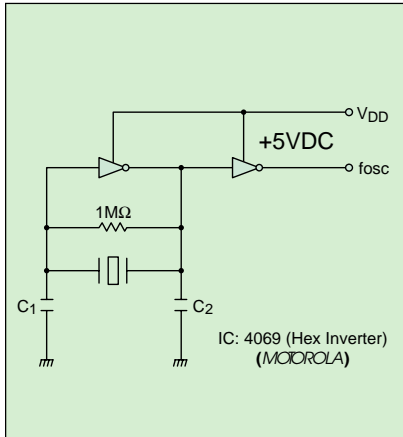

SUGGESTED LAND PATTERNS

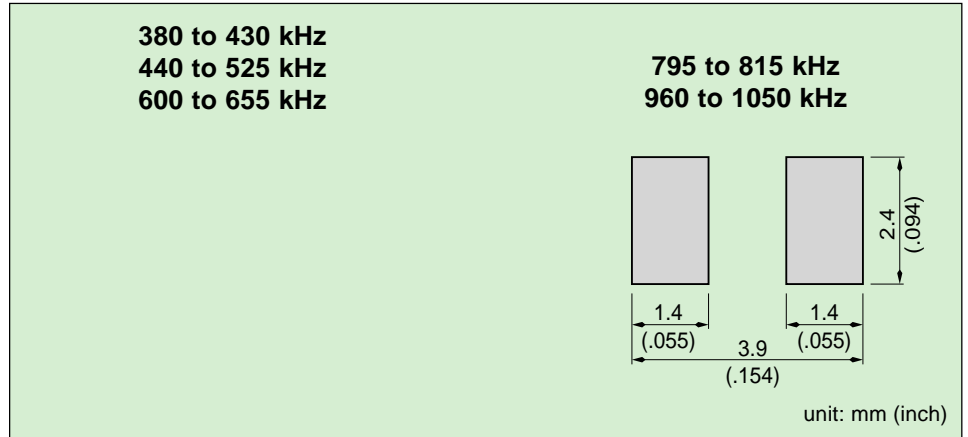

PACKAGING (KBR-□Y TYPE)

TAPE DIMENSIONS – 380 TO 430 / 440 TO 525 / 600 TO 655 kHz

| A | B | C | D | E | F | G | H | J | K | L | M | N | P | Q | R | S | T | U |
|------|------|------|-------|------|------|------|------|------|------|------|-------|------|------|------|-------|------|------|------|
| ±0.2 | ±0.2 | ±0.2 | ±0.2 | ±0.3 | ±0.2 | ±0.1 | ±0.1 | ±0.1 | ±0.1 | ±0.1 | 10max | ±0.2 | ±0.2 | ±0.2 | | ±0.2 | ±0.1 | ±0.2 |
| 6.7 | 8.5 | 8.7 | 11.25 | 16.0 | 7.5 | 1.75 | 12.0 | 4.0 | 2.0 | 1.5 | | 4.8 | 4.1 | 4.3 | .3max | 1.7 | 0.4 | 1.9 |

TAPE DIMENSIONS – 795 TO 815 / 960 TO 1050 kHz

| A | B | C | D | E | F | G | H | J | K | L | M | N | P | Q | R | S | T | U |
|------|------|------|------|------|------|------|------|------|------|------|-------|------|------|------|-------|------|------|------|
| ±0.2 | ±0.2 | ±0.2 | ±0.2 | ±0.3 | ±0.2 | ±0.1 | ±0.1 | ±0.1 | ±0.1 | ±0.1 | 10max | ±0.2 | ±0.2 | ±0.2 | | ±0.2 | ±0.1 | ±0.2 |
| 3.9 | 5.5 | 5.7 | 8.55 | 16.0 | 7.5 | 1.75 | 8.0 | 4.0 | 2.0 | 1.5 | | 3.6 | 2.9 | 3.1 | .3max | 1.7 | 0.4 | 1.9 |

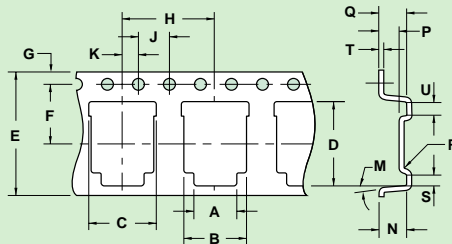

Note: Quantity per reel equals 1000 pieces.

unit: mm

REEL DIMENSIONS – 380 TO 430 / 440 TO 525 / 600 TO 655 kHz

| A | B | C | D | E | R | W | T |
|------|------|------|------|------|------|------|--------|
| ±1.5 | ±1.0 | ±0.5 | ±0.5 | ±0.5 | | ±2.5 | |
| 330 | 80 | 13 | 21 | 2.0 | 1.0R | 17.5 | 3.0max |

REEL DIMENSIONS – 795 TO 815 / 960 TO 1050 kHz

| A | B | C | D | E | R | W | T |
|------|------|------|------|------|------|------|--------|
| ±1.5 | ±1.0 | ±0.5 | ±0.5 | ±0.5 | | ±2.5 | |
| 250 | 80 | 13 | 21 | 2.0 | 1.0R | 17.5 | 2.5max |

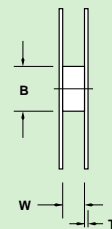
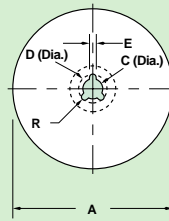

unit: mm

KBR -B, -BK, -F Series Ceramic Resonators

kHz Band Ceramic Resonators

f_o : 190 to 1050 kHz

FEATURES

- 1) Optimum selection of oscillation parameters possible according to application
- 2) Highly reliable design with excellent environmental resistance
- 3) Standard frequency range of 190 kHz to 1050 kHz
- 4) Formed lead type also standardized for use in low profile devices
- 5) Packaged in bags of 500 pcs.
- 6) Sold in increments of 2000 pcs.

HOW TO ORDER

KBR - 455 BK TS

- ① ② ③ ④
- ① Type: (Kyocera Bulk Resonator)
 - ② Oscillation frequency:
190 to 1050 kHz
 - ③ Resonator types:
B/BK = 190 to 680 kHz
F = 795 to 1050 kHz
 - ④ Lead style:
□ = Standard
TS = Single-in-line
TL = Formed lead



SPECIFICATIONS (KBR-□B/KBR-□BK/KBR-□F)

| Configuration | Fig. A | Fig. B | Fig. C | Fig. D | Fig. E | | | Fig. F | | Fig. G | |
|--|----------------|----------------|----------------|----------------|------------------|----------------|----------------|----------------|----------------|----------------|-----------------|
| Type | B | B | BK | B | BK | BK | BK | B | B | F | F |
| Frequency Range | 190 to 249 kHz | 250 to 379 kHz | 380 to 430 kHz | 431 to 439 kHz | 440 to 525 kHz | 540 to 599 kHz | 600 to 655 kHz | 526 to 539 kHz | 656 to 680 kHz | 795 to 815 kHz | 960 to 1050 kHz |
| Frequency Tolerance | ±0.5% | ±0.5% | ±0.5% | ±0.5% | ±0.5% | ±0.5% | ±0.5% | ±0.5% | ±0.5% | ±0.5% | ±0.5% |
| Resonant Impedance | 20 Max | 20 Max | 20 Max | 20 Max | 20 Max | 20 Max | 50 Max | 20 Max | 50 Max | 70 Max | 100 Max |
| Antiresonant Impedance | 25k Min | 30k Min | 30k Min | 30k Min | 35k Min | 35k Min | 50k Min | 35k Min | 50k Min | 70k Min | 70k Min |
| C ₁ | 330pF | 220pF | 100pF | 100pF | 100pF | 100pF | 100pF | 100pF | 100pF | 100pF | 100pF |
| C ₂ | 470pF | 470pF | 470pF | 470pF | 100pF | 100pF | 100pF | 100pF | 100pF | 100pF | 100pF |
| Temperature Characteristics (-20 to +80°C) | ±0.3% | ±0.3% | ±0.3% | ±0.3% | ±0.3% | ±0.3% | ±0.3% | ±0.3% | ±0.3% | ±0.3% | ±0.3% |
| (-40 to +85°C) | +0.3% -0.5% | +0.3% -0.5% | +0.3% -0.5% | +0.3% -0.5% | +0.3% -0.5% | +0.3% -0.5% | +0.3% -0.5% | +0.3% -0.5% | +0.3% -0.5% | +0.3% -0.5% | +0.3% -0.5% |
| Standard Oscillation Frequency | 200kHz | 300kHz | 400kHz | — | 455, 480, 500kHz | 540, 560kHz | 600, 640kHz | — | 680kHz | 800kHz | 1000kHz |
| Case Color | Blue | Blue | Blue | Blue | Blue | Blue | Blue | Blue | Blue | Green | Green |

TEST CIRCUIT

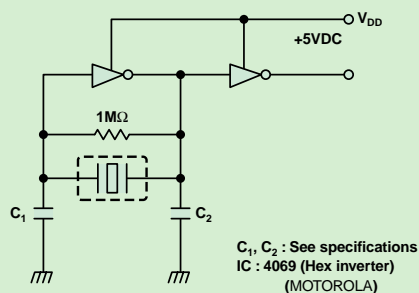

KBR -B, -BK, -F Series Ceramic Resonators

kHz Band Ceramic Resonators

f_o : 190 to 1050 kHz

DIMENSIONS

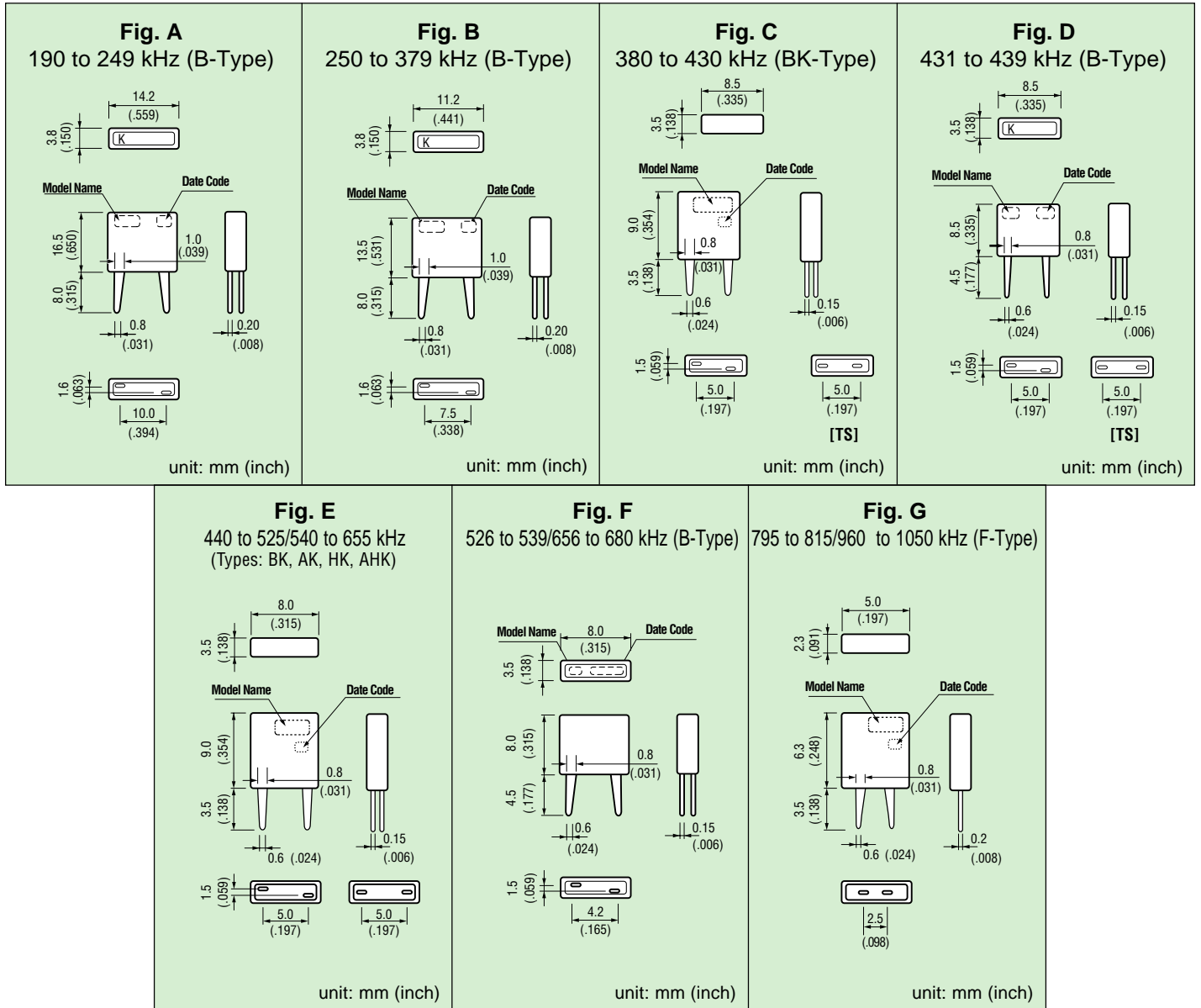

LEAD FORMATIONS

| Lead Type | Lead Shape | Frequency Range | | | | | | | | |
|-----------|------------|-----------------|-----------|--|----------------|---|-----------|-----------------|-----------|-----------|
| | | B-Type | | BK-Type | | F-Type | | | | |
| TS | | — | | 380 to 430 kHz 440 to 525 kHz 540 to 655 kHz | | 795 to 815 kHz 960 to 1050 kHz Single in-line is standard for F series | | | | |
| TL | | 250 to 379 kHz | A* 3.0 | B* 3.0 | 380 to 430 kHz | A* 3.5 | B* 5.0 | 795 to 815 kHz | A* 1.9 | B* 1.9 |
| | | 431 to 439 kHz | 4.5 | 6.0 | 440 to 525 kHz | 3.5 | 5.0 | 960 to 1050 kHz | 1.9 | 1.9 |
| | | 526 to 539 kHz | 4.5 | 6.0 | 540 to 655 kHz | 3.5 | 5.0 | | | |
| | | 656 to 680 kHz | 4.5 | 6.0 | | | | | | |

*Dimensions in mm.

kHz Band Ceramic Resonators

SPECIAL RESONATORS

| Application | Model No. | Oscillation Frequency | Variable Frequency Range | Resonant Impedance | Anti-resonant Impedance | Temperature Characteristics | Dimensions (page 11) | IC | | |
|---|-----------------|-----------------------|--------------------------|--------------------|-------------------------|-----------------------------|----------------------|-----------------------|----------|--------------------|
| Horizontal synchronous oscillator control circuit of TV set | KBR-503.5AKTS1 | 504.5±2.0kHz | ±15kHz min. | 30 max. | — | ±0.5% max. (-20°C~+80°C) | Fig. E | LA7620 (SANYO) | | |
| | KBR-503.5AKTS12 | 504.5±2.0kHz | ±12.8kHz min. | | | | | LA7650(SANYO) | | |
| | KBR-503.5AKTS16 | 501.7±2.0kHz | | | | | | LA7680(SANYO) | | |
| | KBR-503.5AKTS2 | 503.5±2.0kHz | ±15kHz min | | | | | μPC1400C(NEC) | | |
| | KBR-503.5AKTS3 | 503.5±2.0kHz | ±15kHz min | | | | | μPC1401CA (NEC) | | |
| | KBR-503.5AKTS4 | 525.6±2.0kHz *1 (fr) | 52±10kHz *2 (f) | | | | | M51307SP (MITSUBISHI) | | |
| | KBR-503.5AKTS5 | 516.4±2.0kHz*1 (fr) | 51±10kHz *2 (f) | | | | | μPC1403CA (NEC) | | |
| Horizontal synchronous detection circuit of VCR | KBR-500AHKTS2 | 500.0±1.5kHz | — | 20 max. | 70k min. | ±0.6% max. (-20°C~+80°C) | Fig. E | LA2710LA7212 | | |
| | KBR-503.5AHKTS2 | 503.5±1.5kHz | | | | | | LA7215 (SANYO) | | |
| FM stereo MPX | KBR-457HKTS | 18.950kHz±38Hz | 17.0kHz min. *2 (f) | 20 max. | 70k min. | ±0.2% max. (-15°C~+75°C) | Fig. E | LA3400N,LA3401 | | |
| | KBR-457HKTS1 | | | | | | | LA3410,LA3430 (SANYO) | | |
| | KBR-912F102 | 912kHz±0.3% | 38kHz min. *2 (f) | 100 max. | 30k min. | — | Fig. G | LA3400 (SANYO) | | |
| | KBR-912F103 | | | | | | | TA2080F (TOSHIBA) | | |
| | KBR-912F104 | | | | | | | TA2046FN (TOSHIBA) | | |
| KBR-912F108 | LA1867M(SANYO) | | | | | | | | | |
| | | | | | | | | LA1780M(SANYO) | | |
| Detection of search stop signal of electronic tuner | KBR-450AHKTS5 | 450.0±0.5kHz *1 (fr) | 9.0±2.0kHz *2 (f) | 30 max. | — | ±0.5% max. (-20°C ~ +60°C) | Fig. E | — | | |
| | KBR-450AHKTS8 | 450.0±0.8kHz *1 (fr) | | | | | | | | |
| | KBR-450AHKTS1 | 450.0±1.0kHz *1 (fr) | | | | | | | | |
| | KBR-459AHKTS5 | 459.0±0.5kHz *1 (fr) | | | | | | | | |
| | KBR-459AHKTS8 | 459.0±0.8kHz *1 (fr) | | | | | | | | |
| | KBR-459AHKTS1 | 459.0±1.0kHz *1 (fr) | | | | | | | | |
| RF modulator for PAL system | KBR-500AHKTS15 | 500.0±1.5kHz | — | 20 max. | 70k min. | ±0.3% max. (-20°C ~ +80°C) | Fig. E | BA7004 (Rohm) | | |
| | KBR-500AHKTS3 | 500.0±1.5kHz | | | | | | LA7053 (SANYO) | | |
| FDD motor control circuit | KBR-491.5BKOL2 | 491.5kHz±0.3% | — | 20 max. | 35 min. | ±0.3% max. (-20°C ~ +80°C) | — | HA13440MP(HITACHI) | | |
| | KBR-983FOL1 | 983kHz±0.3% | | 100 max. | 70k min. | | | HA13468MP(HITACHI) | | |
| | KBR-610.2BKOL4 | 610.2kHz±0.3% | | 50 max. | 50k min. | | | M51785(MITSUBISHI) | | |
| | KBR-460.8BK4 | 460.8kHz±0.3% | | 20 max. | 35k min. | | | BA6472 (Rohm) | | |
| Telephone unit | KBR-480BKTS3 | 480kHz±0.3% | — | 20 max. | 35k min. | ±0.3% max. (-20°C~ +80°C) | Fig. E | TC31018P(TOSHIBA) | | |
| | KBR-480BKTS-TM1 | 480kHz±0.3% | | | | | | 100 max. | 70k min. | TMP47C26N(TOSHIBA) |
| | KBR-960F3 | 960kHz±0.3% | | | | | | | | Fig. G |

*1: f_r =resonant frequency, *2: $f = f_a - f_r$ (f_a =anti-resonant frequency), *3: When used in conjunction with special stereo MPX IC's.

APPLICATION CIRCUITS

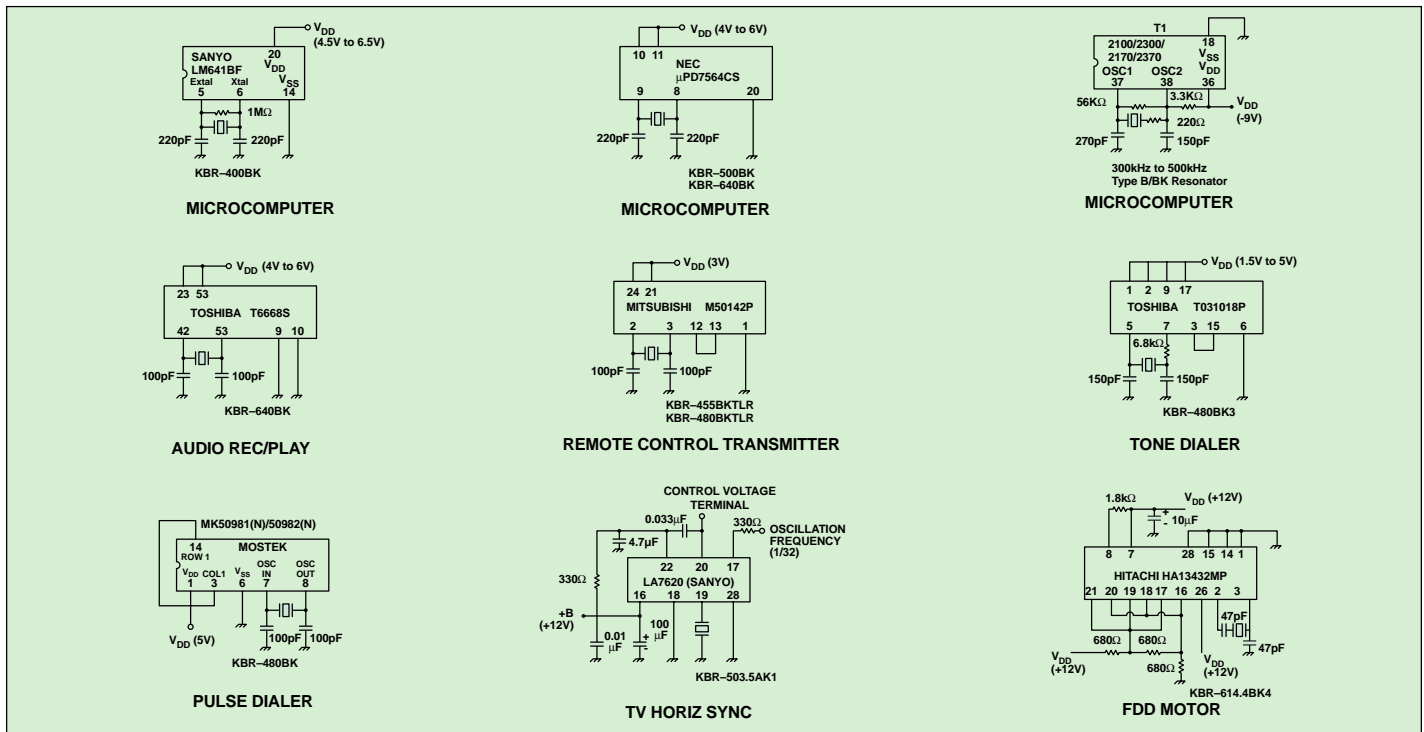

PBRC -A Series Chip Resonators

MHz Band SMT Resonators

f_0 : 2.00 to 8.00 MHz

FEATURES

- 1) High reliability chip resonator in a ceramic case which can be reflow soldered and washed
- 2) Ultra-miniature size is suitable for compact equipment and high mounting density
- 3) Rectangular shape allows easy "pick and place" operation
- 4) 2000 pcs. per reel
- 5) Sold in increments of 2000 pcs.

HOW TO ORDER

PBRC - 4.00 A R

- ① ② ③ ④

- ① Type: (Piezo Bulk Resonator Chip)
- ② Oscillation frequency (MHz)
- ③ Resonator type:
A = Without capacitor
- ④ Packaging:
R = Tape and reel



STRUCTURE

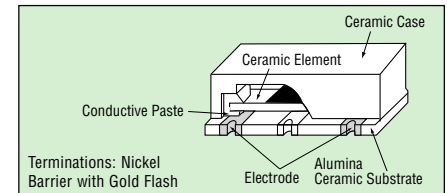

SPECIFICATIONS (PBRC-□A)

| | |
|---|---|
| Frequency Range | 2.00 to 8.00 MHz |
| Frequency Tolerance | ±0.5% |
| Resonant Impedance | 200Ω Max at 2.00~2.90MHz 100Ω Max at 3.00~3.57MHz 30Ω Max at 3.58~8.00MHz |
| Temperature Characteristics (-20 to +80°C) | ±0.3% |

RECOMMENDED LAND PATTERN FOR PBRC-□A

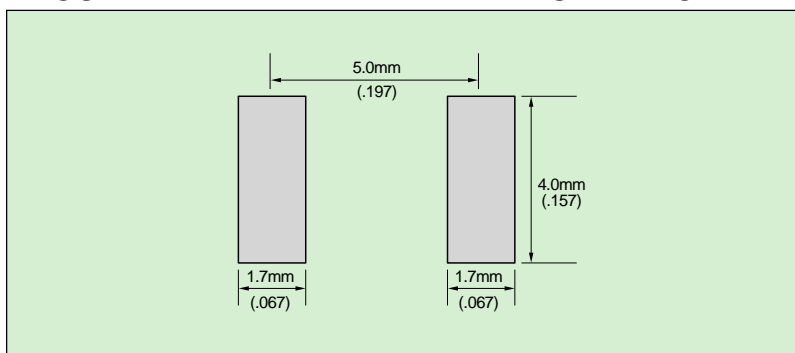

STANDARD TEST CIRCUIT

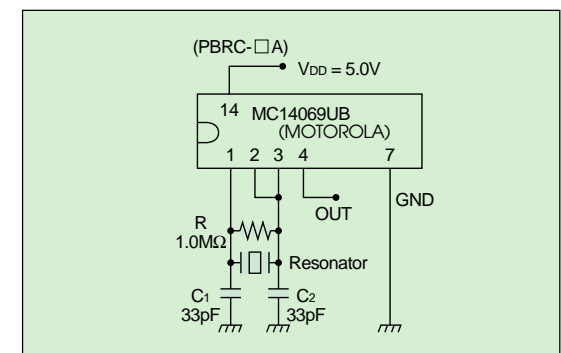

DIMENSIONS

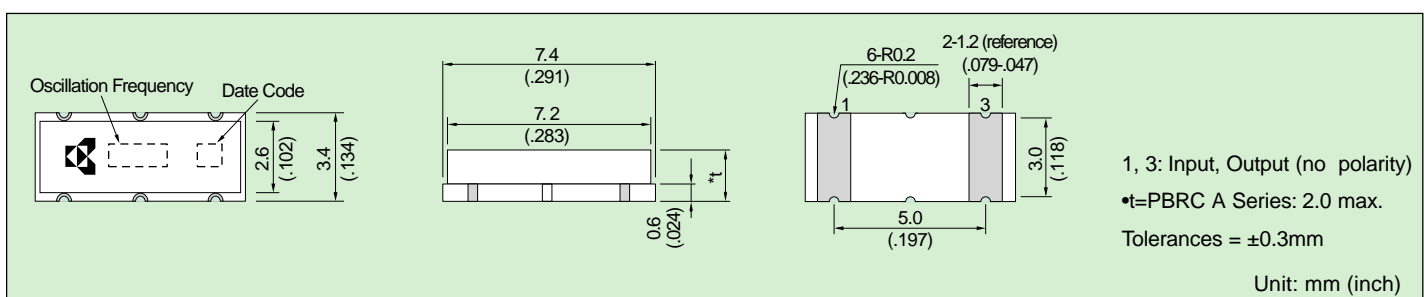

PBRC -B, -D Series Chip Resonators

Built-in Capacitor MHz Band SMT Resonators

f_o : 2.00 to 36.00 MHz

FEATURES

- 1) Built-in load capacitor
- 2) High reliability chip resonator in a ceramic case which can be reflow soldered and washed
- 3) Ultra-miniature size is suitable for compact equipment and high mounting density
- 4) Rectangular shape allows easy "pick and place" operation
- 5) 2000 pcs. per reel
- 6) Sold in increments of 2000 pcs.

HOW TO ORDER

PBRC - 4.00 B R

- ① Type: (Piezo Bulk Resonator Chip)
- ② Oscillation frequency (MHz)
- ③ Resonator type:
B = With capacitor (2.00~20.00MHz)
D = With capacitor (20.01~36.00MHz)
- ④ Packaging:
R = Tape and reel
- ⑤ Frequency tolerance:
□ = ±0.5% (2.00~8.00MHz)
07 = ±0.7% (8.01~20.00MHz)
□ = ±0.5% (20.01~36.00MHz)

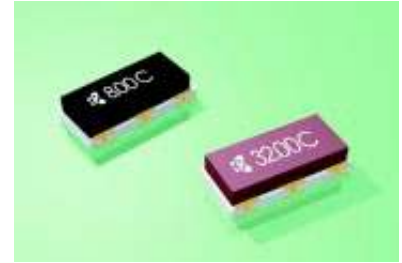

STRUCTURE

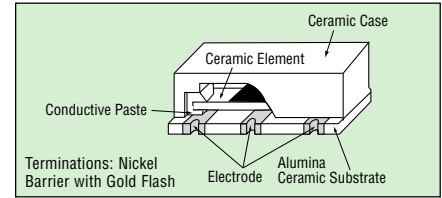

SPECIFICATIONS (PBRC-□B/PBRC-□D)

| Series Type | B | | D |
|--|--|------------------------------------|--|
| Frequency Range | 2.00 to 8.00 MHz | | 8.01 to 20.00 MHz |
| Load Capacitor | 33 pF (typ.) | | 10 pF (typ.) |
| Frequency Tolerance | ±0.5% | | ±0.7% |
| Resonant Impedance | 2.00-2.90MHz 3.00-3.57MHz 3.58-8.00MHz | 200Ω max. 100Ω max. 30Ω max. | 150 Ω Max. 150 Ω Max. 150 Ω Max. |
| Temperature Characteristics (-20 to +80°C) | ±0.3% | | ±0.1% |

RECOMMENDED LAND PATTERN FOR PBRC-□B/D

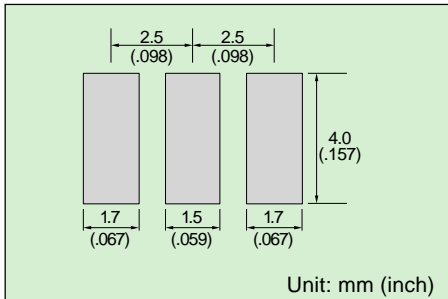

STANDARD TEST CIRCUIT 2.00 ~ 8.00 MHz

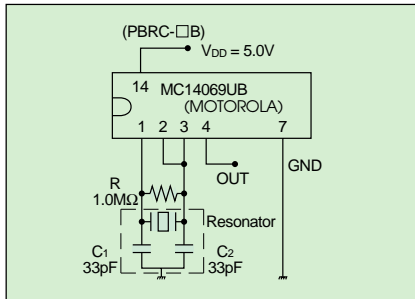

STANDARD TEST CIRCUIT 8.01 ~ 36.00 MHz

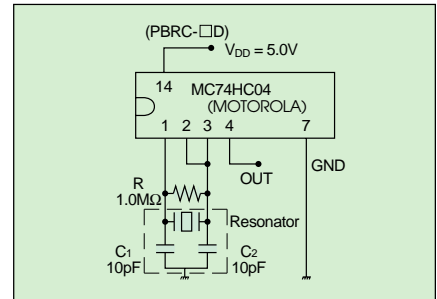

DIMENSIONS

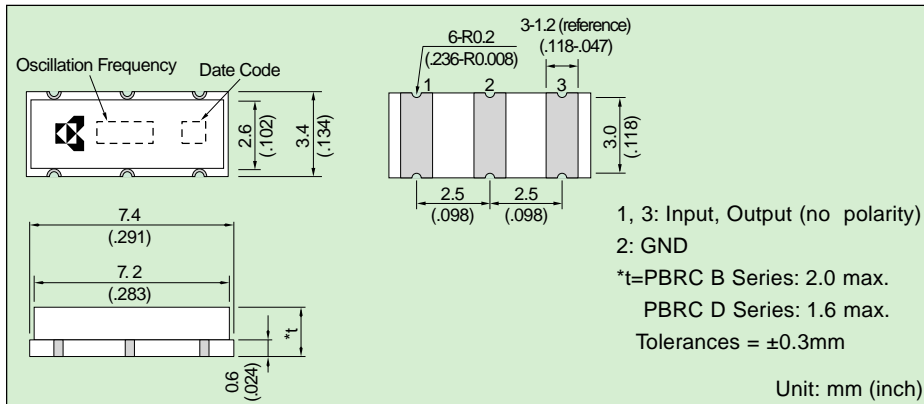

PAD CONNECTION

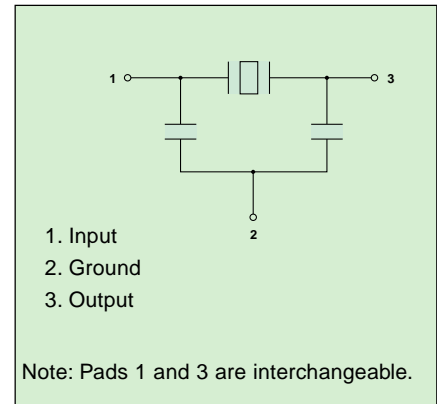

Tape & Reel Packaging

Surface Mountable Chip Resonators PBRC -A, -B, -D Types

2000 pieces per reel with 10 positions open at beginning and end of reel. Leader will be 200mm maximum.

TAPE DIMENSIONS

| A | B | D | E | F | G | H | J | φK | M | R | W | T | φL |
|------|------|------|------|------|------|------|------|------|--------|--------|------|------|-------|
| ±0.2 | ±0.2 | ±0.3 | ±0.1 | ±0.1 | ±0.1 | ±0.1 | ±0.1 | ±0.1 | | | ±0.2 | ±0.1 | ±0.05 |
| 3.8 | 7.8 | 16.0 | 7.5 | 1.75 | 8.0 | 4.0 | 2.0 | 1.5 | 10°max | 0.3max | 2.1 | 0.3 | 1.55 |

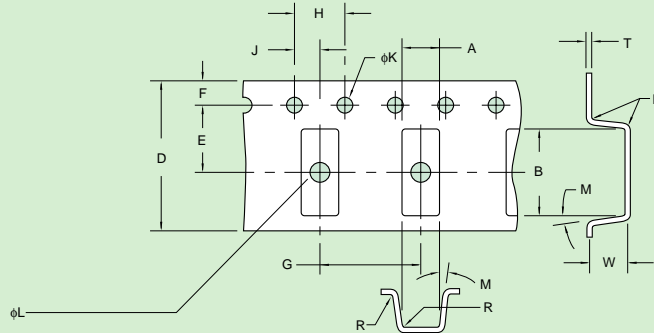

Units:mm

REEL DIMENSIONS

| A | B | C | D | E | R | W | T |
|------|------|------|------|------|------|------|------|
| 255 | 80 | 13 | 25 | 2 | 1.0R | 17.5 | 2 |
| ±1.0 | ±0.5 | ±0.5 | ±0.8 | ±0.5 | | ±1.5 | ±0.5 |

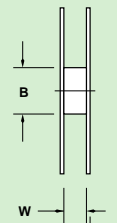
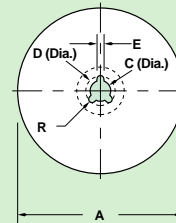

Units:mm

PACKING METHOD

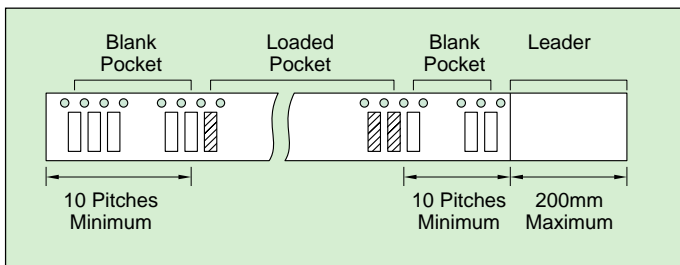

TEST CONDITION OF PEELING STRENGTH

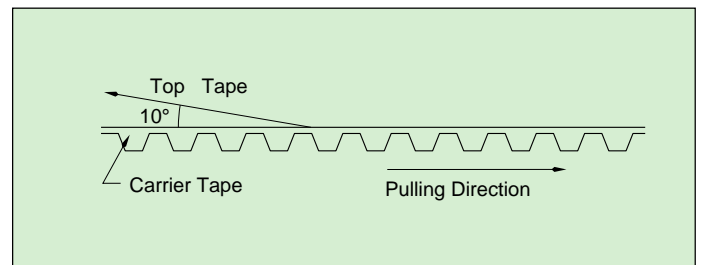

MARKING

Marking of Reel

- Type Name
- Lot No.
- Quantity
- Vendor Name

Marking of Exterior Package

- Type Name
- Lot No.
- Quantity of Reel
- Shipping Date
- Vendor Name

REFLOW PROFILE

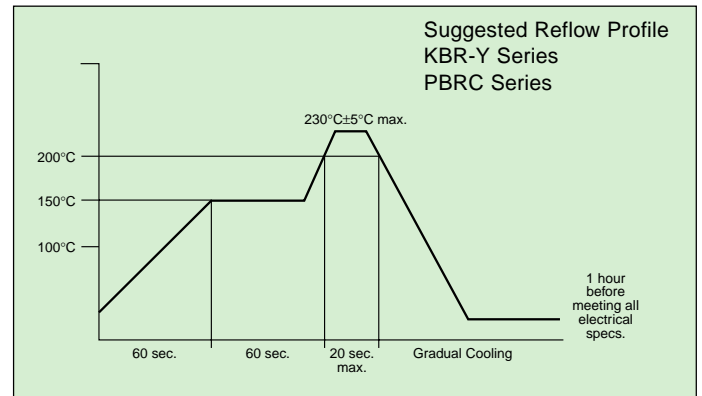

Capacitor Built-In Type Chip

MHz Band Ceramic Resonators - SSR-B Series

FEATURES

- 1) World's smallest (2.1x3.2x1.5 mm)
- 2) High density mounting possible
- 3) Wide frequency range in same case size
- 4) 2000 pieces per reel
- 5) Sold in increments of 2000 pieces

HOW TO ORDER

SSR 33.86 B R

- ① ② ③ ④
- ① Type: (Super Small Resonator)
 - ② Oscillating frequency
 - ③ Resonator type: B = With capacitor
 - ④ Packaging: R = Tape and reel



SPECIFICATIONS

| Frequency Range | Frequency Tolerance | Resonant Impedance | Temperature Stability (-20~80°C) | IC | Popular Frequencies |
|-----------------|---------------------|--------------------|----------------------------------|----------------------|---------------------------|
| 16~60MHz | ±0.5% | 100 max. | ±0.3% | MC74HCU04 (MOTOROLA) | 16, 25, 27, 29, 33.86, 40 |

DIMENSIONS

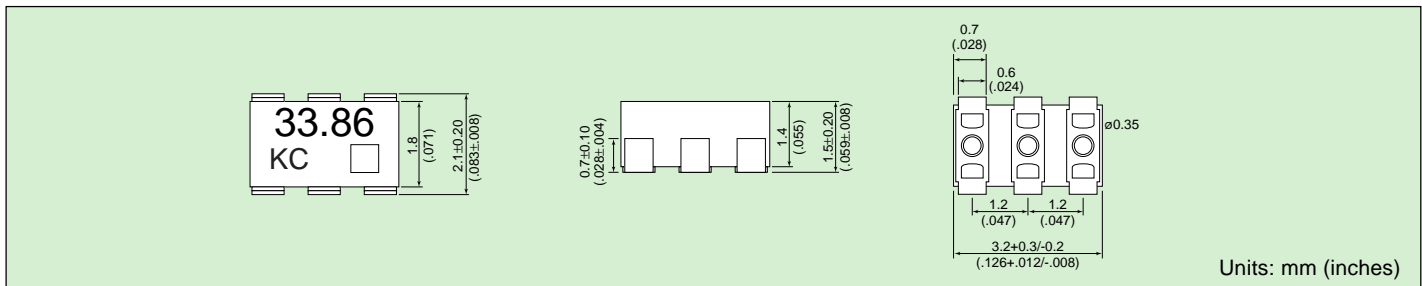

TEST CIRCUIT

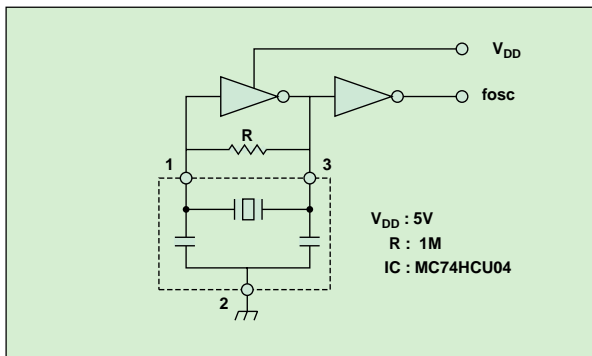

RECOMMENDED LAND PATTERN

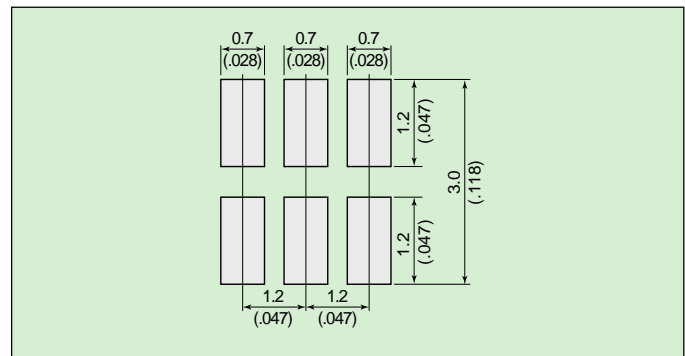

PACKAGING: TAPE and REEL

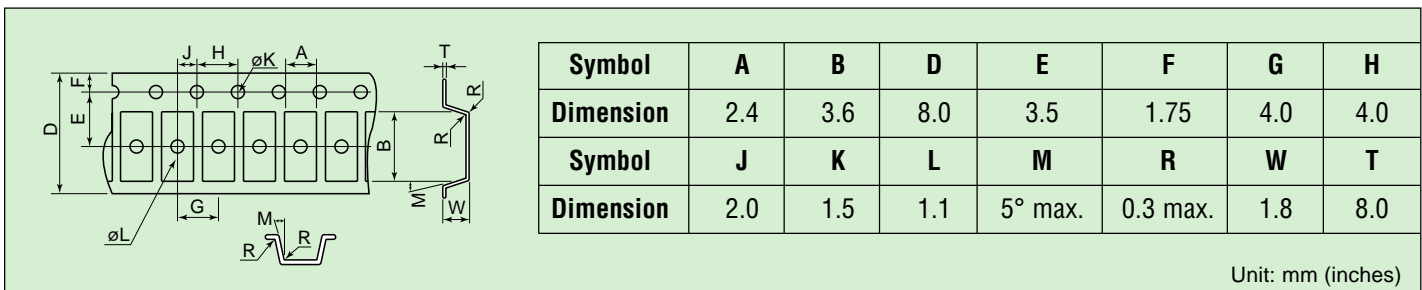

KBR -M, -MS, -MSA, -MSB Series Ceramic Resonators

MHz Band Ceramic Resonators

f_o : 2.00 to 13.00 MHz

FEATURES

- 1) Ultracompact, lightweight design
- 2) Resistant to damage from impact and vibration
- 3) Excellent temperature stability ($\pm 0.3\%$)
- 4) Low cost
- 5) Bulk packaged 500 pieces per bag or 2000 pieces per reel
- 6) Sold in increments of 200 pieces

HOW TO ORDER

KBR - 4.00 MSA TR

- ① ② ③ ④
- ① Type: (Kyocera Bulk Resonator)
 - ② Oscillation frequency (MHz)
 - ③ Resonator type:
 MS = 2.00 to 3.57 MHz
 MSA = 3.58 to 8.00 MHz (Water resistant)
 MSB = 3.58 to 6.00 MHz ("No-Clean" Process only)
 M = 6.01 to 13.00 MHz
 - ④ Packaging:
 TR = Tape and reel
 □ = Bulk



SPECIFICATIONS (KBR-□MS/KBR-□MSA/KBR-□MSB/KBR-□M Series)

| Series | MS | MSA, -MSB | M | M |
|---|------------------|------------------|------------------|-------------------|
| Dimension | Fig. A | Fig. B | Fig. C | Fig. D |
| Oscillation Frequency | 2.00 to 3.57 MHz | 3.58 to 8.00 MHz | 6.01 to 6.99 MHz | 7.00 to 13.00 MHz |
| Frequency Tolerance | $\pm 0.5\%$ | $\pm 0.5\%$ | $\pm 0.5\%$ | $\pm 0.5\%$ |
| Resonant Impedance | 100 Max | 30 Max | 40 Max | 40 Max |
| Temperature Characteristic (-20 to +80°C) | $\pm 0.3\%$ | $\pm 0.3\%$ | $\pm 0.5\%$ | $\pm 0.5\%$ |

DIMENSIONS

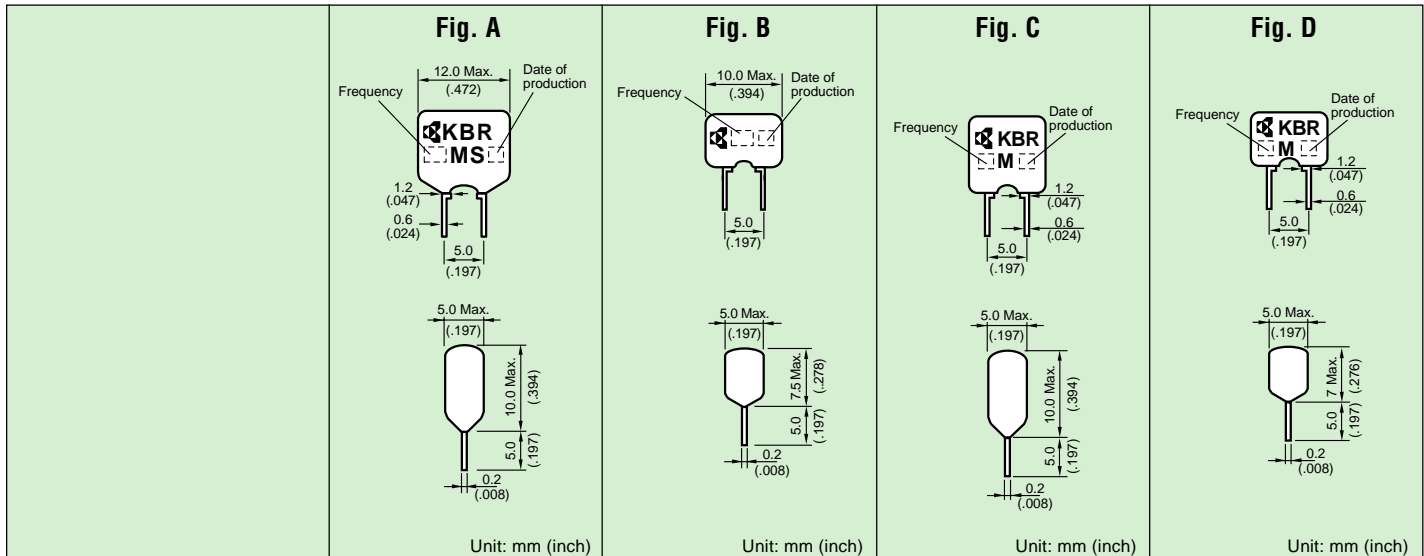

KBR-3.58MSA - 200 series for Telephone D.T.M.F. Applications

| P/N | Frequency | Frequency Tolerance | Resonant Resistance | Temperature Stability (-20 to +80°C) | Dimensions |
|-----------------|-----------|---------------------|---------------------|--------------------------------------|------------|
| KBR-3.58MSA-201 | 3.5795MHz | +0 -0.25% | 30 Max | $\pm 0.3\%$ | Fig. B |
| KBR-3.58MSA-202 | | +0.15 -0.10% | | | |
| KBR-3.58MSA-203 | | +0.30 -0.05% | | | |
| KBR-3.58MSA-204 | | +0.45 +0.20% | | | |
| KBR-3.58MSA-205 | | +0.60 +0.35% | | | |
| KBR-3.58MSA-206 | | -0.30 -0.55% | | | |
| KBR-3.58MSA-207 | | -0.15 -0.40% | | | |

TEST CIRCUIT

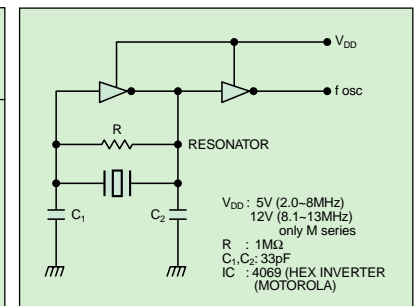

KBR -MY Series Ceramic Resonators

High Frequency MHz Band Ceramic Resonators f_o : 13.01 to 36.00 MHz

FEATURES

- 1) High frequency resonator to match high-speed needs
- 2) Faster start-up time as compared to quartz crystals
- 3) High durability
- 4) Bulk packaged 500 pieces per bag or 2000 pieces per reel
- 5) Sold in increments of 2000 pieces

HOW TO ORDER

KBR - 16.00 MSA TR

- ① Type: (Kyocera Bulk Resonator)
- ② Oscillation frequency (MHz)
- ③ Resonator type:
MY = CMOS IC
MSA = Standard
- ④ Packaging:
□ = Bulk
TR = Tape and reel



SPECIFICATIONS (KBR-□MY/KBR-□MSA)

| Series Type | KBR -MY | KBR -MSA |
|--|--------------------|----------------|
| Frequency Range | 13.01 to 15.99 MHz | 16.00 to 36.00 |
| Frequency Tolerance | ±0.5% | ±0.5% |
| Resonant Impedance | 30 max. | 30 max. |
| Temperature Characteristics (-20 to +80°C) | ±0.3% max. | ±0.3% max. |

DIMENSIONS

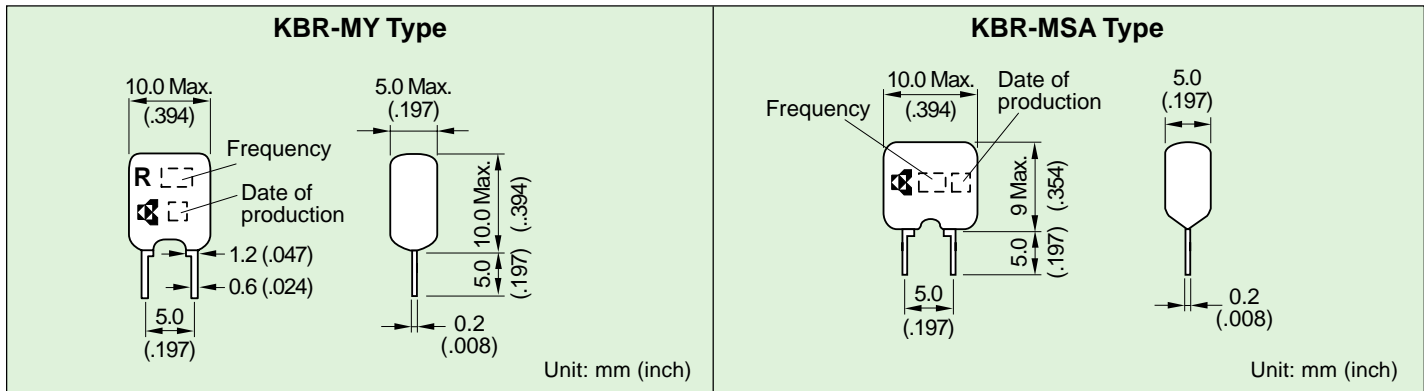

STANDARD TEST CIRCUIT

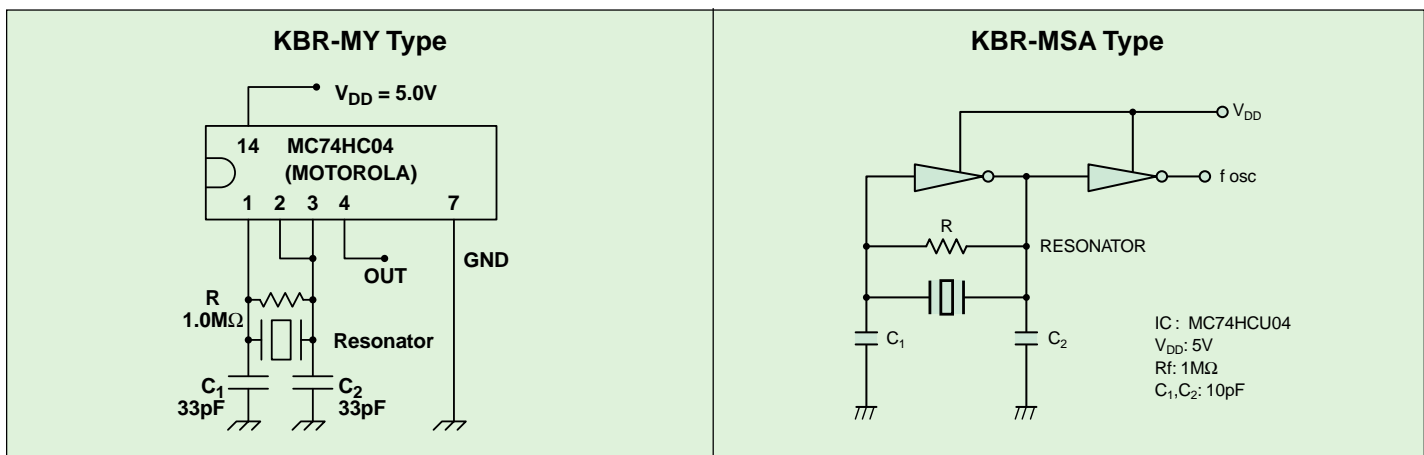

KBR -MKC, -MKD, -MKS Series Ceramic Resonators

Built-in Capacitor MHz Band Ceramic Resonators f_o : 3.45 to 8.00 MHz
16.00 to 36.00 MHz

FEATURES

- 1) Built-in load capacitance
- 2) Simplified circuit
- 3) Reduced parts cost
- 4) Reduced mounting cost
- 5) High density mounting
- 5) Bulk packaged 500 pieces per bag or 2000 pieces per reel
- 7) Sold in increments of 2000 pieces

HOW TO ORDER

KBR - 4.00 MKC TR

- ① Type: (Kyocera Bulk Resonator)
- ② Oscillation frequency (MHz)
- ③ Resonator type:
MKC = "No-Clean" Process only
MKD = Water resistant
MKS = Standard
- ④ Packaging:
□ = Bulk
TR = Tape and reel



SPECIFICATIONS (KBR-□MKC/KBR-□MKD/KBR-□MKS)

| Series Type | KBR -MKC, -MKD, -MKS | KBR -MKD |
|--|----------------------|----------------|
| Frequency Range | 3.45 to 8.00 MHz | 16.00 to 36.00 |
| Frequency Tolerance | ±0.5% | ±0.5% |
| Resonant Impedance | 30 | 30 |
| Temperature Characteristics (-20 to +80°C) | ±0.5% | ±0.3% |

DIMENSIONS

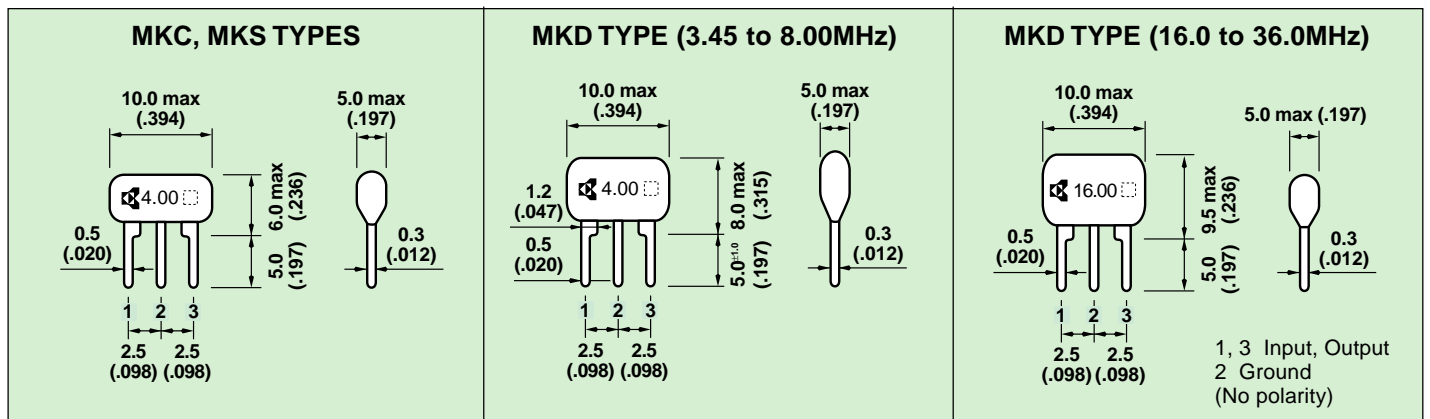

Unit: mm (inch)

Tolerance ±0.2mm unless otherwise specified

TEST CIRCUIT

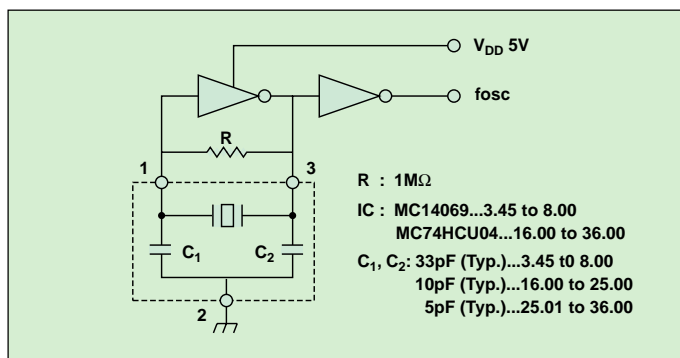

PIN CONNECTION (No Polarity)

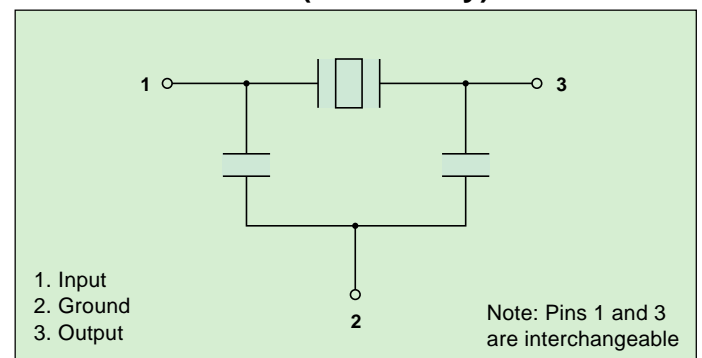

Tape & Reel Packaging

MHz Ceramic Resonators

TAPE AND REEL PACKAGING

- 2000 pieces per reel
- Min. of 3 open positions at the beginning and end of tape

AMMO PACK

- 2000 pieces per package
- A minimum of 38.1mm or three positions shall be open at beginning and end of tape
- Each fold shall be 317.35mm in length or the equivalent of twenty-five positions

HOW TO ORDER

KBR - [] [] TR

- ① ② ③ ④

- ① Type: (Kyocera Bulk Resonator)
- ② Oscillation frequency (MHz)
- ③ Resonator type = M/MS/MSA/MSB/MY/MKC/MKD
- ④ Packaging:
TR = Tape and reel
TF = Ammo pack

TAPE DIMENSIONS

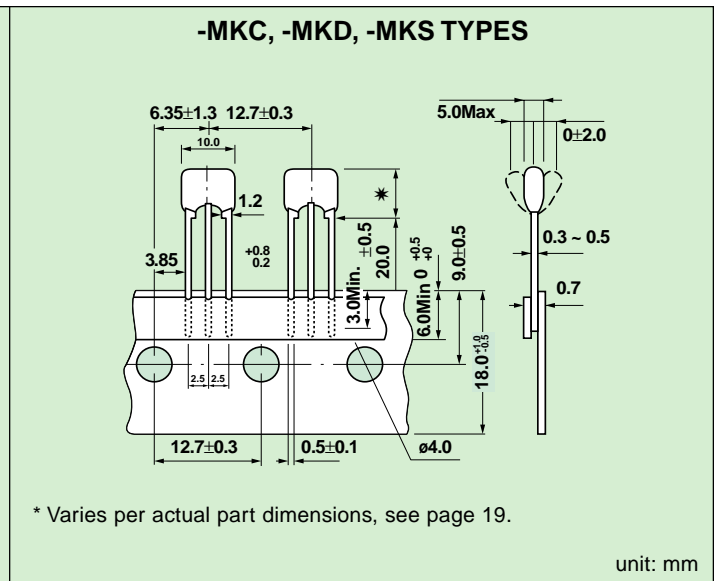
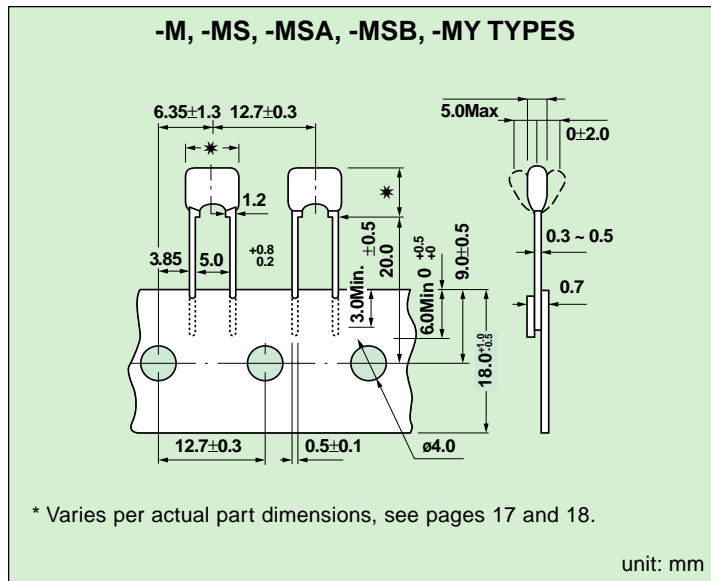

REEL DIMENSIONS

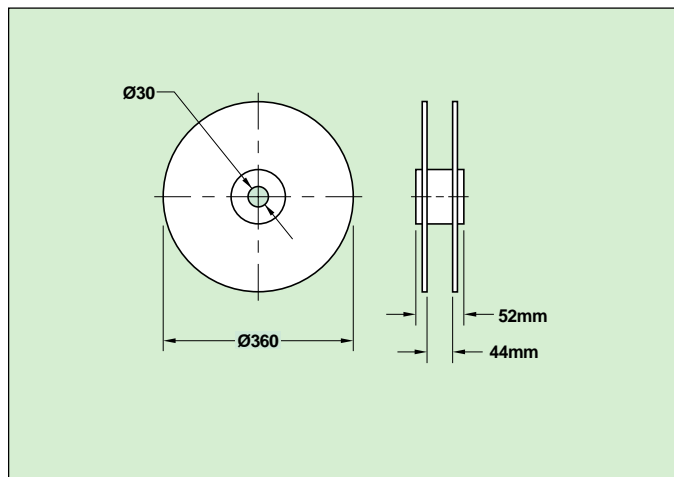

AMMO PACK DIMENSIONS

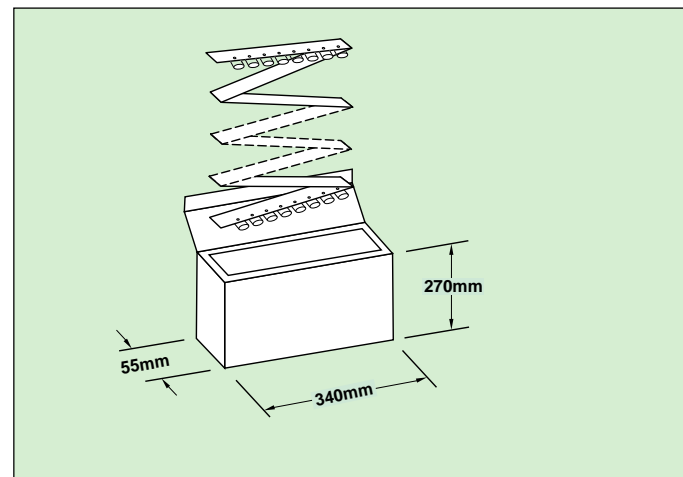

Surface Acoustic Wave Resonators

GENERAL DESCRIPTION

The fundamental wave oscillation of AVX/Kyocera Surface Acoustic Wave (SAW) Resonators eliminates spurious response, which leads to a reduction in the number of components used for spurious frequency suppression. This feature, in addition to the good shock resistance characteristics of the SAW resonator, helps to simplify the assembly process and promotes higher stability.

Kyocera Surface Acoustic Wave (SAW) resonators are ideal for use in RF modulators for videotape recorders, video discs and cable television. These unique SAW resonators contain two channels in one package. Custom design features can be manufactured for specific applications.

TEST CIRCUIT

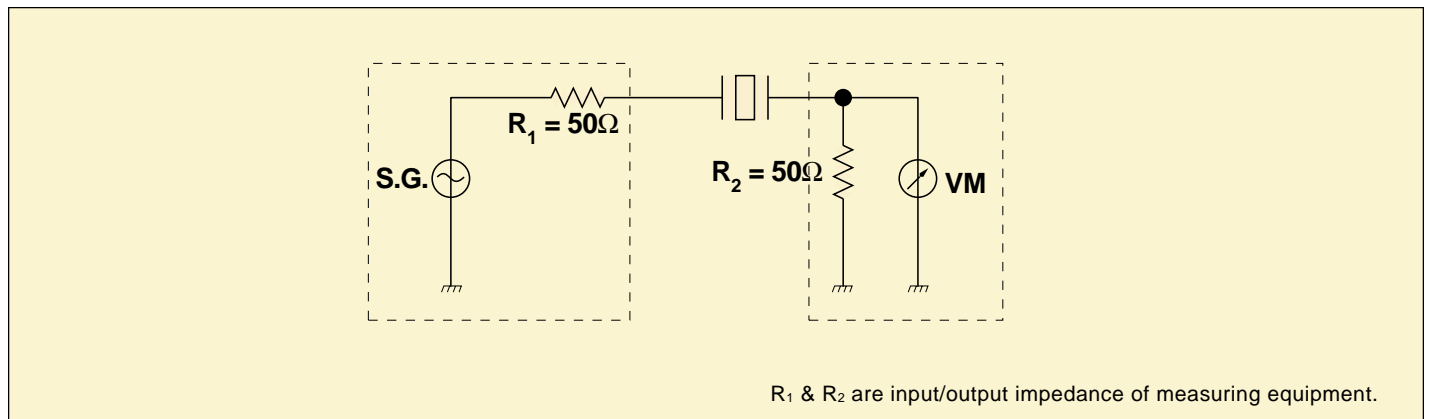

ENVIRONMENTAL CHARACTERISTICS

| TEST | CONDITION |
|-------------------------------|--|
| High Temperature Storage Test | +85±2°C |
| Low Temperature Storage Test | -40°±2°C |
| Humidity Loading Test | 40±2°C, 90%RH, 6VDC |
| Solderability Test | 260±10°C, 10±1 sec. |
| Thermal Shock Test | -20°C 30 min., 70°C 30 min. 5 cycles |
| Shock Test | 90G: 6 msec XYZ direction totally 18 times |

Surface Mount SAW Resonators

PAR Series

FEATURES

- 1) Frequency range: 300 to 450 MHz
- 2) 1 port type SMD resonator
- 3) Small size (5.5X3.8mm)
- 4) Low profile (1.5mm max)
- 5) SMT ceramic package
- 6) Excellent temperature characteristics: +100ppm ~ -250ppm (-40 ~ 85°C)
- 7) 2000 pieces per reel
- 8) Sold in increments of 2000 pieces

HOW TO ORDER

PAR S 433.92 K 04 R

- ① SMT SAW Resonator
- ② Type: C = Glass seal, S = Seam weld
- ③ Frequency
- ④ Marking code (please see table)
- ⑤ Freq. Tolerance or custom spec.
 00 : ±250KHz 01 : ±200KHz
 02 : ±150KHz 03 : ±100KHz
 04 : ±75KHz 10 : Tolerance
 11 : Custom spec.
- ⑥ Package: R=Tape & reel



ELECTRICAL CHARACTERISTICS

| Part Number | Resonant Frequency (MHz) | Resonant Loss (dB) | Parallel Capacitance (pF) |
|-----------------|--------------------------|--------------------|---------------------------|
| PARS 304.45LXXR | 304.45 | 2.5 max. | 4.0 max. |
| PARS 310.00KXXR | 310.00 | 2.5 max. | 4.0 max. |
| PARS 314.00KXXR | 314.00 | 2.5 max. | 3.2 max. |
| PARS 314.50LXXR | 314.50 | 2.5 max. | 3.2 max. |
| PARS 315.00KXXR | 315.00 | 2.5 max. | 3.2 max. |
| PARS 320.65KXXR | 320.65 | 2.5 max. | 3.2 max. |
| PARS 423.22KXXR | 423.22 | 2.5 max. | 3.2 max. |
| PARS 432.92KXXR | 432.92 | 2.5 max. | 3.2 max. |
| PARS 433.42LXXR | 433.42 | 2.5 max. | 3.2 max. |
| PARS 433.92KXXR | 433.92 | 2.5 max. | 3.2 max. |

RECOMMENDED LAND PATTERN

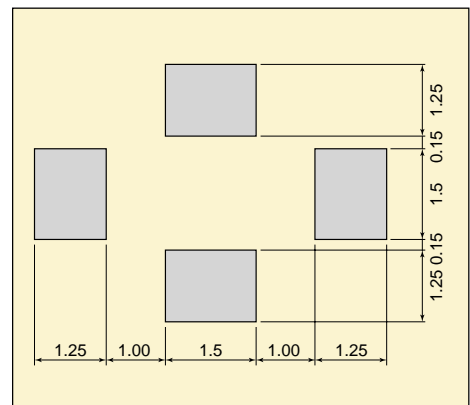

DIMENSIONS

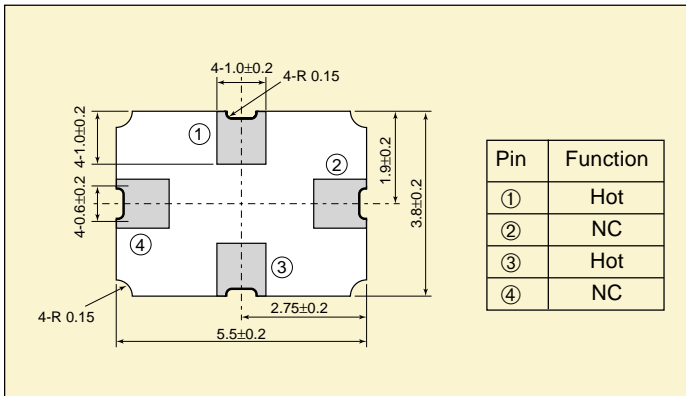

MARKING CODE

| Resonant Frequency (MHz) | Marking Code |
|--------------------------|--------------|
| 304.45 | 304 L |
| 310.00 | 310 K |
| 314.00 | 314 K |
| 314.50 | 314 L |
| 315.00 | 315 K |
| 320.65 | 320 K |
| 423.22 | 423 K |
| 432.92 | 432 K |
| 433.42 | 433 L |

Monthly Code

(4 digits Frequency Marking)

BLOCK DIAGRAM (Example application)

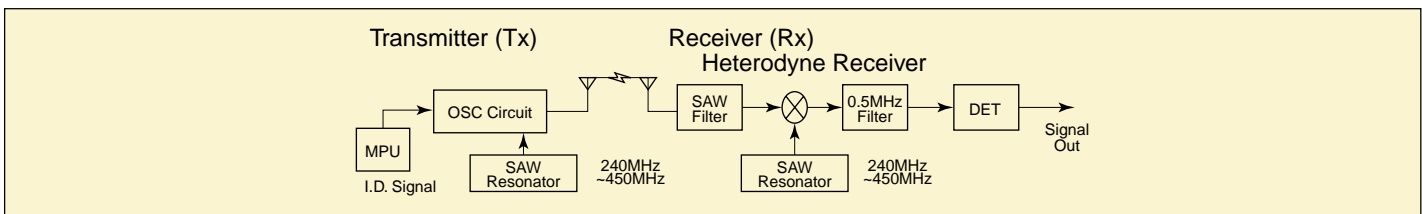

KAR Series SAW Resonators

MHz Band SAW Resonators

f_0 : 46 to 315 MHz

FEATURES

- 1) 2 channels encased in one package
- 2) Utilization of fundamental wave oscillation suppresses spurious response
- 3) No adjustment of peripheral circuits required
- 4) Good vibration and shock resistance
- 5) Superior temperature stability
- 6) Reduces the number of peripheral components

HOW TO ORDER

KAR-91-CS

① ② ③

- ① Type: (Kyocera Acoustic Resonator)
- ② Oscillation frequency (MHz)
- ③ Resonator type:
 CS, CT = Small package – Fig. B
 CD, CB = Standard package – Fig. A
 CK, CL = Round shape package – Fig. C.
 CF, CG = Small square package – Fig. D.



STRUCTURE

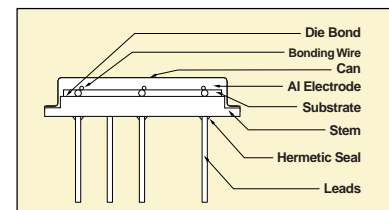

SPECIFICATIONS (KAR-□-□)

| Part No. | Channel* | Resonant Frequency (MHz)** | Resonant Loss (dB) | Parallel Capacitance (pF) | Temperature Stability -10°C to +60°C (ppm/°C) | Dimension |
|-----------|------------------|----------------------------|--------------------|---------------------------|---|-----------|
| KAR-55CT | U- $\frac{2}{3}$ | 55.24±0.08 61.24±0.08 | 6.0 MAX | 3.6±1 3.7±1 | ±8 | Figure A |
| KAR-83CB | U- $\frac{5}{6}$ | 77.24±0.08 83.24±0.08 | 4.0 MAX | 4.5±1 4.2±1 | ±7 | |
| KAR-55CS | W- $\frac{3}{4}$ | 55.24±0.08 62.24±0.08 | 5.0 MAX | 4.8±1 4.8±1 | ±8 | |
| KAR-86CB | A- $\frac{3}{4}$ | 86.24±0.08 95.24±0.08 | 3.0 MAX | 4.2±1 4.0±1 | ±5 | |
| KAR-85CB | O- $\frac{4}{5}$ | 85.24±0.08 93.24±0.08 | 3.0 MAX | 4.2±1 4.0±1 | ±5 | |
| KAR-61CT | U- $\frac{3}{4}$ | 61.24±0.08 67.24±0.08 | 5.0 max | 4.4±1 2.8±1 | ±8 | Figure B |
| KAR-77CS | O- $\frac{3}{4}$ | 77.24±0.08 85.24±0.08 | 4.5 MAX | 3.1±1 2.8±1 | ±8 | |
| KAR-91CS | J- $\frac{1}{2}$ | 91.24±0.08 97.24±0.08 | 3.0 MAX | 4.0±1 4.0±1 | ±5 | |
| KAR-211CS | U-13 | 211.24±0.15 | 2.7 MAX | 3.0±1 | ±8 | |

*J: Japan U: USA W: Germany A: Australia O: East Europe

**Other frequencies available on request.

SPECIFICATIONS (for Keyless Entry)

| Part No. | Channels | Resonant Frequency (MHz) | Resonant Loss (dB) | Parallel Capacitance (pF) | Temperature Characteristics (ppm/°C) | Dimension |
|-----------|----------|--------------------------|--------------------|---------------------------|--------------------------------------|-----------|
| KAR-303CS | JPN | 303.875±0.25 | 2.5 Max. | 4.0 Max. | ±8 Max. | Fig. B |
| KAR-304CS | US | 304.30±0.25 | | | | |
| KAR-310CS | US | 310.00±0.25 | | 3.2 Max. | | |
| KAR-314CS | US | 314.00±0.25 | | | | |
| KAR-314CT | US | 314.50±0.25 | | | | |
| KAR-315CS | US | 315.00±0.25 | | | | |
| KAR-320CS | JPN | 320.65±0.25 | | | | |
| KAR-345CS | US | 345.00±0.25 | | | | |
| KAR-359CS | US | 359.90±0.25 | | | | |
| KAR-417CS | UK | 417.50±0.25 | | 2.3 Max. | | |
| KAR-418CS | UK | 418.00±0.25 | | | | |
| KAR-423CS | EU | 423.22±0.25 | | | | |
| KAR-432CS | EU | 432.92±0.25 | | | | |
| KAR-433CS | EU | 433.92±0.25 | | | | |
| KAR-433CT | EU | 433.42±0.25 | | | | |
| KAR-479CS | JPN | 479.50±0.5 | | | | |

SAW Resonators Sample Circuits

RF Modulators

SPECIFICATIONS (for Keyless Entry)

| Part No. | Channels | Resonant Frequency (MHz) | Resonant Loss (dB) | Parallel Capacitance (pF) | Temperature Characteristics (ppm/°C) | Dimension |
|-----------|----------|--------------------------|--------------------|---------------------------|--------------------------------------|-----------|
| KAR-303CK | JPN | 303.875±0.25 | 2.5 Max. | 4.0 Max. | ±8 Max. | Fig. C |
| KAR-304CK | US | 304.30±0.25 | | | | |
| KAR-310CK | US | 310.00±0.25 | | | | |
| KAR-314CK | US | 314.00±0.25 | | | | |
| KAR-314CL | US | 314.50±0.25 | | | | |
| KAR-315CK | US | 315.00±0.25 | | | | |
| KAR-320CK | JPN | 320.65±0.25 | | | | |
| KAR-345CK | US | 345.00±0.25 | | | | |
| KAR-359CK | US | 359.90±0.25 | | | | |
| KAR-417CK | UK | 417.50±0.25 | | | | |
| KAR-418CK | UK | 418.00±0.25 | | | | |
| KAR-423CK | EU | 423.22±0.25 | | | | |
| KAR-432CK | EU | 432.92±0.25 | | | | |
| KAR-433CK | EU | 433.92±0.25 | | | | |
| KAR-433CL | EU | 433.42±0.25 | | | | |
| KAR-479CK | JPN | 479.50±0.5 | 2.3 Max. | | | |
| KAR-303CF | JPN | 303.875±0.25 | 2.5 Max. | 4.0 Max. | ±8 Max. | Fig. D |
| KAR-304CF | US | 304.30±0.25 | | | | |
| KAR-310CF | US | 310.00±0.25 | | | | |
| KAR-314CF | US | 314.00±0.25 | | | | |
| KAR-314CG | US | 314.50±0.25 | | | | |
| KAR-315CF | US | 315.00±0.25 | | | | |
| KAR-320CF | JPN | 320.65±0.25 | | | | |
| KAR-345CF | US | 345.00±0.25 | | | | |
| KAR-359CF | US | 359.90±0.25 | | | | |
| KAR-417CF | UK | 417.50±0.25 | | | | |
| KAR-418CF | UK | 418.00±0.25 | | | | |
| KAR-423CF | EU | 423.22±0.25 | | | | |
| KAR-432CF | EU | 432.92±0.25 | | | | |
| KAR-433CF | EU | 433.92±0.25 | | | | |
| KAR-433CG | EU | 433.42±0.25 | | | | |
| KAR-479CF | JPN | 479.50±0.5 | 2.3 Max. | | | |

*JPN: Japan U: United States EU: Europe

* For other frequencies, please contact your nearest sales office.

DIMENSIONS

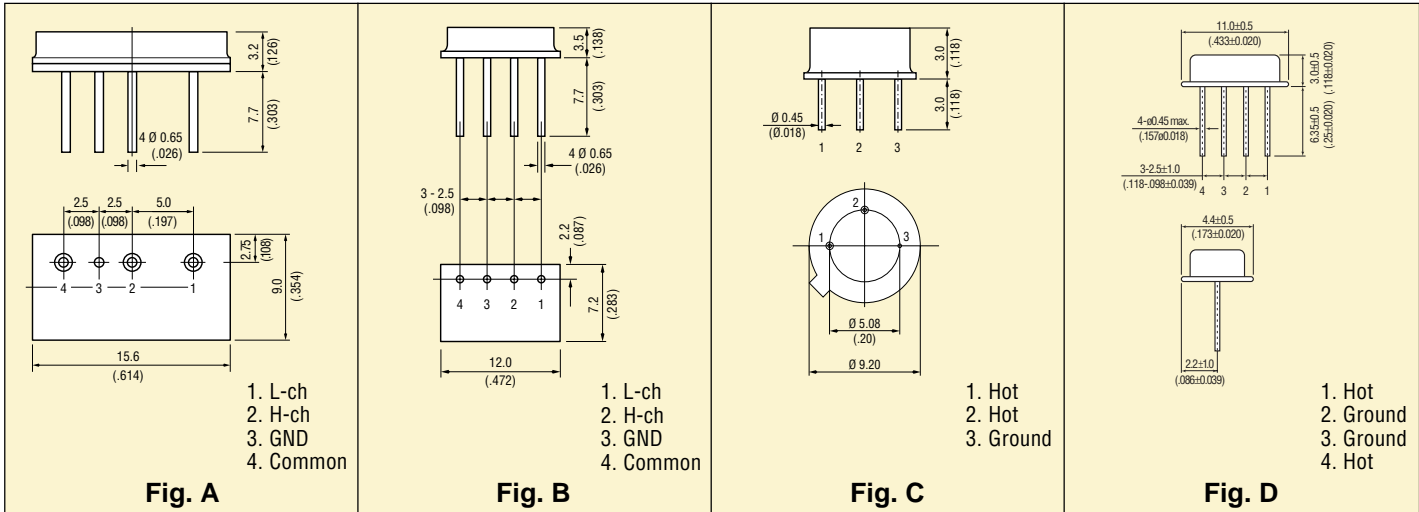

Surface Acoustic Wave Resonators

**ATTENUATION vs FREQUENCY
KAR-61CT
U.S. CHANNEL 3**

**IMPEDANCE and PHASE ANGLE
KAR-61CT
U.S. CHANNEL 3**

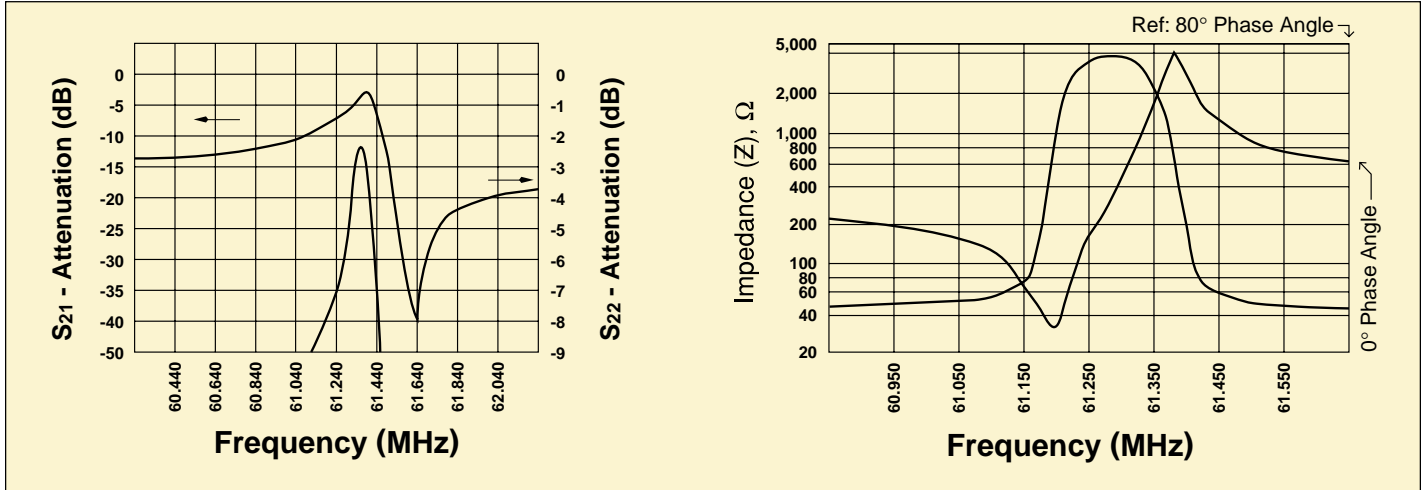

**Attenuation Change at Resonance with Temperature
KAR-61CT**

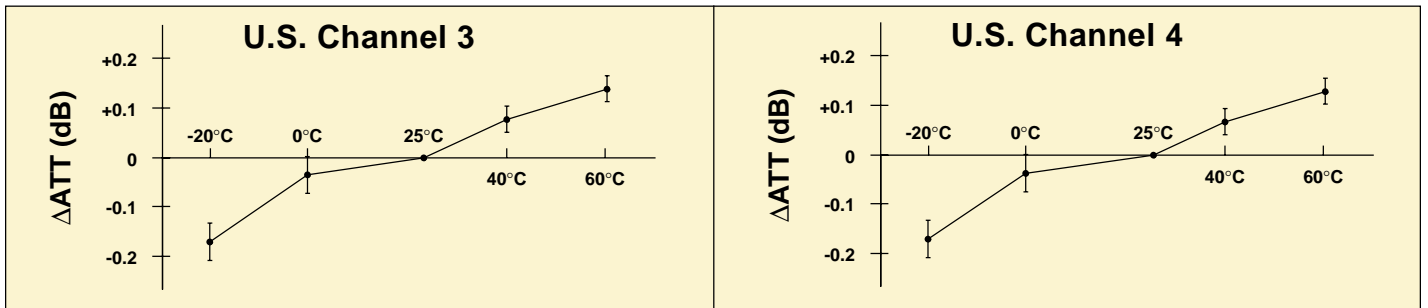

**Resonant Frequency Change with Temperature
KAR-61CT**

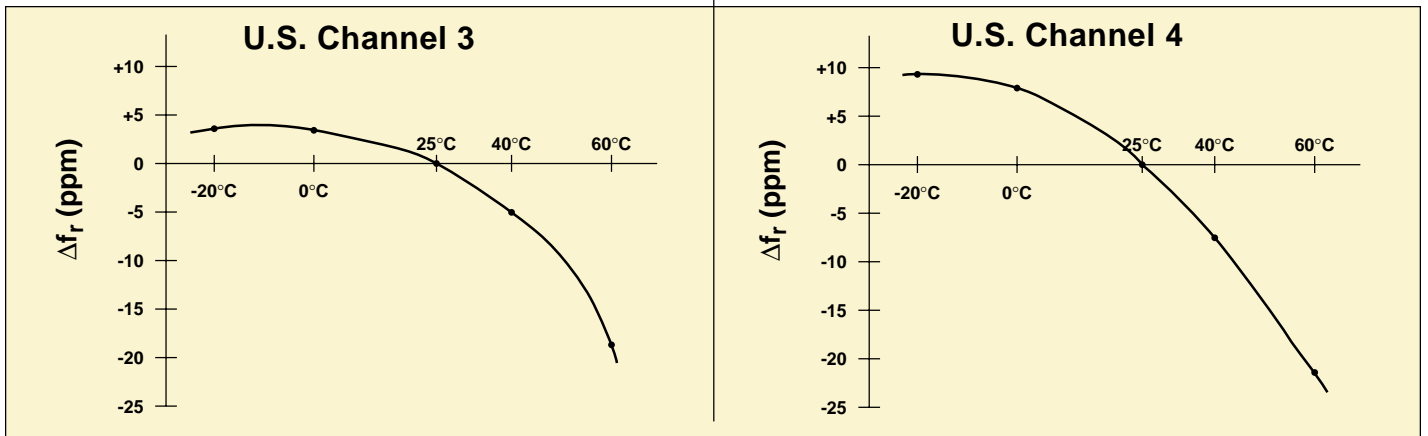

MHz Band Quartz Crystals

SMD Type - KSX Series

FEATURES

- 1) Reference frequency for telecommunicaton system
- 2) High reliability ceramic package
- 3) 1000 pieces per reel
- 4) Sold in increments of 2000 pieces

HOW TO ORDER

KSX - 36 - 192M - ****

- ① Model: KSX-36
 ② Frequency: 19.2 MHz
 ③ Specification: 4 digits on end of part number

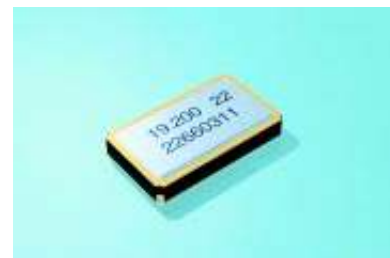

SPECIFICATIONS (KSX)

| Parameters | Code | Specification | Remarks |
|-------------------------------------|--------------|--|--|
| Frequency Range | fo | 12~22MHz | See available frequencies below |
| Load Capacitance | CL | 12.0pF | |
| Frequency Tolerance | $\Delta f/f$ | ± 10 ppm | +25 $\pm 2^\circ\text{C}$ |
| Storage Temperature | Tstg | -40 $^\circ\text{C}$ ~+85 $^\circ\text{C}$ | |
| Operating Temperature | Topr | -30 $^\circ\text{C}$ ~+80 $^\circ\text{C}$ | |
| Frequency Stability vs. Temperature | $\Delta f/T$ | ± 10 ppm | -10 $^\circ\text{C}$ ~+60 $^\circ\text{C}$ (+25 $^\circ\text{C}$ standard) |
| Crystal Impedance | CI | 30 (max.) | 0/25/50 $^\circ\text{C}$ & 1 μW /100 μW |

DIMENSIONS

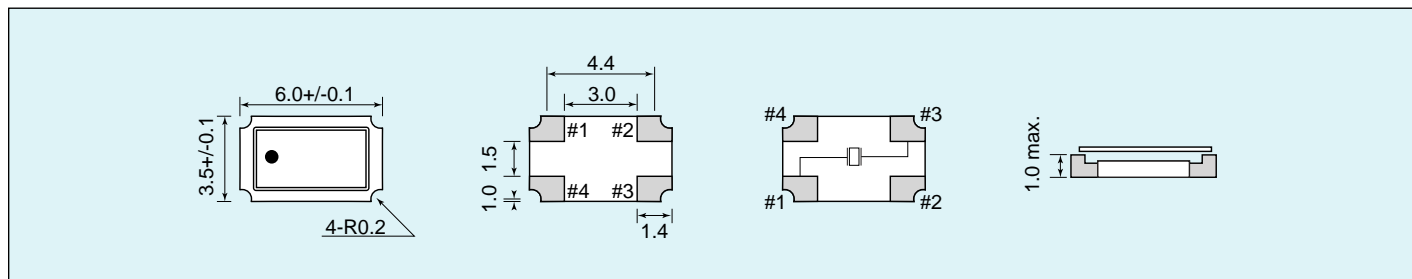

RECOMMENDED LAND PATTERN

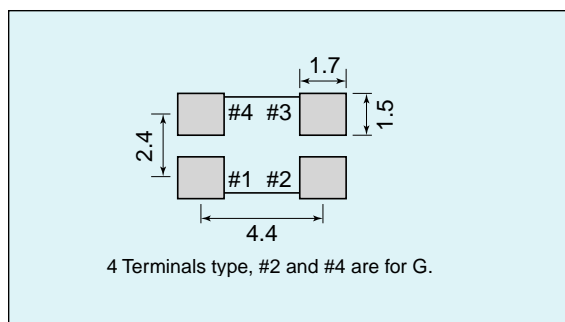

RECOMMENDED REFLOW PROFILE

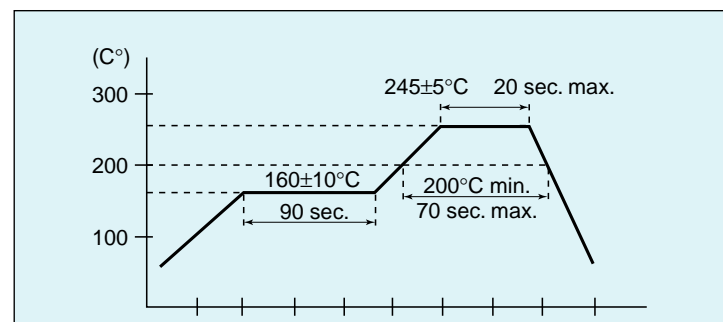

FREQUENCY (MHz)

| | | | | | | | | | |
|--------|--------|--------|---------|--------|--------|--------|--------|--------|--------|
| 12.00 | 12.600 | 13.000 | 13.8650 | 14.850 | 16.368 | 19.200 | 19.800 | 21.145 | 21.400 |
| 12.500 | 12.800 | 13.824 | 14.400 | 15.360 | 16.800 | 19.680 | 20.945 | 21.250 | 26.000 |

MHz Band Quartz Crystals

Leaded Type - KT Series

FEATURES

- 1) Reference frequency for telecommunication system
- 2) High stability of characteristics due to vacuum pack can
- 3) Reflow solderable (Drift after solder: ±1ppm)
- 4) Bulk packaged 500 pieces/bag
- 5) Sold in increments of 2000 pieces

HOW TO ORDER

KT-308 - 192M ****

- ① ② ③
- ① Model: KT-308
 - ② Frequency: 19.2MHz
 - ③ Specification: 4 digits on end of part number

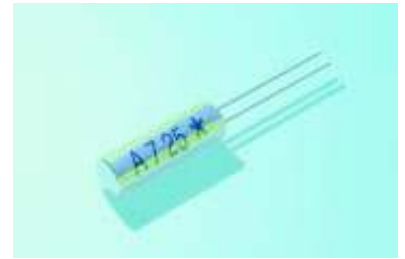

SPECIFICATIONS (KT)

| Parameters | Code | Specification | Remarks |
|-------------------------------------|------|---------------|---------------------------------|
| Frequency Range | fo | 12~22MHz | See available frequencies below |
| Load Capacitance | CL | 13.0pF | |
| Frequency Tolerance | Δf/f | ±10ppm | +25±2°C |
| Storage Temperature | Tstg | -40°C~+85°C | |
| Operating Temperature | Topr | -30°C~+80°C | |
| Frequency Stability vs. Temperature | Δf/T | ±10ppm | -10°C~+60°C (+25°C standard) |
| Crystal Impedance | CI | 30 (max.) | -10/25/50°C & -10dbm/-30dbm |

DIMENSIONS AND MARKING

A : Frequency (19.2MHz)
 7 : Production Year (1997)
 25: Production Week (25th week)
 * : Option

FREQUENCY (MHz)

| | | | | | | | | |
|--------|--------|---------|--------|--------|--------|--------|--------|--------|
| 12.00 | 12.800 | 13.824 | 14.400 | 15.360 | 16.800 | 20.945 | 19.800 | 21.250 |
| 12.600 | 13.000 | 13.8650 | 14.850 | 16.368 | 19.200 | 19.800 | 21.145 | 21.400 |

GENERAL DESCRIPTION

Clock oscillators are devices which generate the pulses to control the timing and operation of logic circuitry. They differ from other components used to control the timing of logic circuits, such as quartz crystals and ceramic resonators, in that clock oscillators need a power supply but no additional external circuitry to operate. Clock oscillators are usually made by combining in a single package a frequency control device such as a quartz crystal, and a hybrid circuit of resistors, capacitors, and either transistors or an integrated circuit. The package is often either a welded steel can or ceramic package hermetically sealed which protects the crystal and electronics from environmental effects and also reduces the unwanted electromagnetic and radio-frequency emissions which oscillators can generate.

OSCILLATION DEVICES

Various types of circuits can be used to generate timing waveforms for electronic devices. The simplest of these is a simple circuit using capacitors, inductors and an active element such as a transistor or operational amplifier. This is an easy, low cost solution but the frequency is not very stable due to temperature and individual component variations. A more stable circuit would utilize a ceramic resonator, which has the advantage of better frequency tolerance, but resonators are only available in certain frequency ranges and stability of $\pm 0.5\%$ is the best that can be achieved. If better frequency stability is needed, then the most popular method is to use a circuit which relies on the piezoelectric properties of quartz crystals to stabilize the oscillation.

If an alternating electrical field is applied to a cut and polished quartz crystal, the crystal lattice will deform due

to what is called the piezoelectric effect. At one particular frequency, which is determined by the geometry and size of the crystal, vibration will occur much more easily than at any other frequency. This is called the “resonant” frequency. If an oscillation circuit is built around this crystal, the mechanical vibrations can be used to control the electrical oscillations very precisely.

AVX/Kyocera builds its high quality clock oscillators from the substrate up. The whole module is hermetically sealed into an all-metal welded package to protect it from humidity. The case is directly grounded into a pin to help minimize RF radiation and meet FCC’s EMI specifications.

A full range of clock oscillators are manufactured by AVX/Kyocera. These extend from 1 MHz up to 72 MHz and include TTL and HCMOS compatible drive levels. AVX/Kyocera also offers special low power consumption clocks for long life battery applications. (See chart page 28.) Application specific designs for critical requirements of today’s high-speed, 32-bit microprocessors are available.

WAVEFORM

The diagram below shows a typical waveform of a clock oscillator with an explanation of the parameters important for correct selection of the appropriate device.

Often called the symmetry of a waveform, duty cycle is a measure of how close to being equal the high and low parts of a waveform are. A perfectly symmetrical waveform will have duty cycle of 50%. We usually specify the minimum and maximum variations of the duty cycle as, for example: 60/40%. This is computed from the times shown on the diagram below as $A/A+B$.

| Series | Output Frequency (MHz) | Fan Out | Output Level | | Features |
|---------------------------|------------------------|---------|----------------------|---------------------|------------------------------|
| | | | V _{OH} Min | V _{OL} Max | |
| TTL | | | | | |
| K50 -HC* -C † | 8 to 68 | 50pF | 0.9 V _{DD} | 0.1 V _{DD} | CMOS/TTL Drive |
| KXO -01 | 8 to 50 | 10 TTL | 2.4 | 0.4 | Cost Performance |
| KXO -HC* -T (KHO -HC* -T) | 1 to 72 | 10 TTL | 2.4 | 0.4 | Versatile Drive Capabilities |
| HCMOS | | | | | |
| K50 -HC* -C † | 8 to 68 | 50pF | 0.9 V _{DD} | 0.1 V _{DD} | CMOS/TTL Drive |
| K50 -CS* -SE | 8 to 50 | 15pF | V _{DD} -0.5 | 0.5 | Low Power Consumption |
| KXO -HC* -C (KHO -HC* -C) | 1 to 72 | 50 pF | 0.9 V _{DD} | 0.1 V _{DD} | Versatile Drive Capabilities |
| 386 -HC | 24,32,40,50 | 7 TTL | 0.9V _{DD} | 0.1 V _{DD} | Drives 80386 |
| Low Voltage | | | | | |
| K50 -3C (3.3V) | 8 to 68 | 15pF | 0.9 V _{DD} | 0.1 V _{DD} | Low Supply Voltage |

†Will also drive TTL. See catalog for details – page 31.

| Cordless & Cellular Phones | Frequency (MHz) | Output | Features |
|----------------------------|---|-----------------|---------------------------------|
| Temperature Compensated | | | |
| KT11 | 12.8, 13.0, 14.4, 14.85, 15.36, 16.8, 19.2 | 1Vp-p/10k /10pF | Surface Mount |
| KT12 | 12.8, 13.0, 14.4, 16.8, 19.2, 19.68 | 1Vp-p/10k /10pF | Miniature Surface Mount |
| KT14 | 13.0, 14.4, 14.85, 16.8, 19.2, 19.44, 19.68, 19.8 | 1Vp-p/10k /10pF | Ultra Low Profile Surface Mount |
| VCO | 200~2000 | | High Performance Surface Mount |

AVX/Kyocera Clock Oscillators

GENERAL DESCRIPTION continued

CLOCK OSCILLATOR APPLICATIONS

In a typical personal computer system 5 or 6 clock oscillators may be used in the main processing unit, for all the add-on boards, video graphics adapters, co-processors, etc., and all the peripheral devices such as printers, modems and networking equipment. Many different companies may be involved in the manufacture of all these individual parts of the system.

The telecommunications industry uses clock oscillators in fax machines, cellular phones, pagers, and radio systems. These oscillators are typically very high precision, temperature compensated and voltage controlled devices.

Clock oscillators are manufactured by combining a quartz crystal into a hybrid module containing passive components and active digital devices.

AVX/Kyocera builds its high quality clock oscillators from the substrate up. The whole module is hermetically sealed into an all-metal welded package to protect it from humidity. The case is directly grounded to a pin to help minimize RF radiation and meet FCC's EMI specifications.

PACKAGING

The diagrams below show the basic design of the 14 pin and 8 pin DIP (dual inline packages) and ceramic SMT packages in which most of the clock oscillators are available. Leaded oscillators are tube packaged. SMT K50 units are tape and reel packaged 1000 units per reel. Tube packages hold 25 units each for the KXO-01 and KXO-HC series, and 40 units each for the KHO-HC series products.

FREQUENCY vs. POWER SUPPLY CURRENT

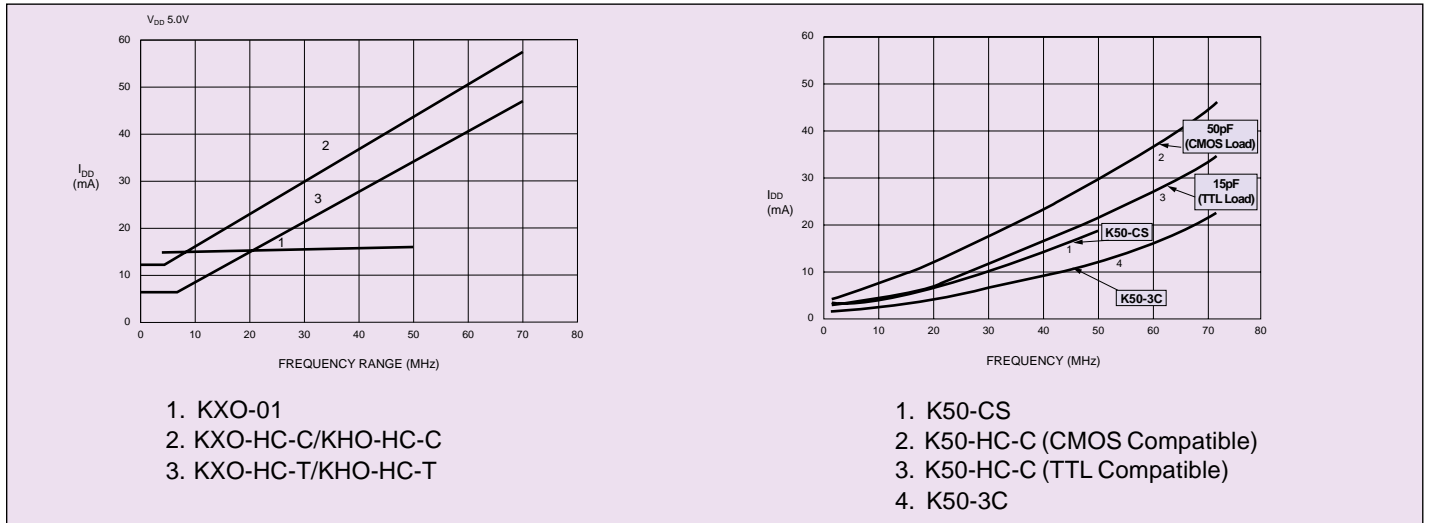

OUTPUT WAVEFORM

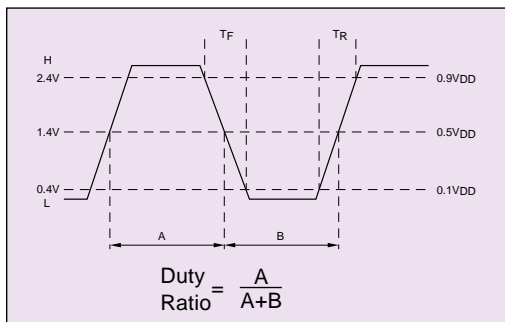

CLOCK OSCILLATOR GENERAL CONSTRUCTION

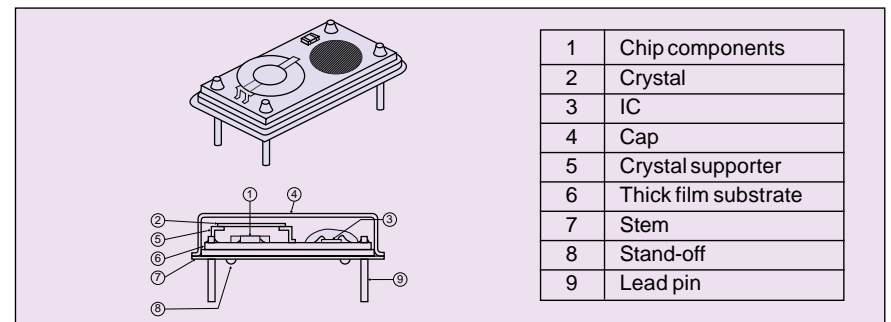

PACKAGES

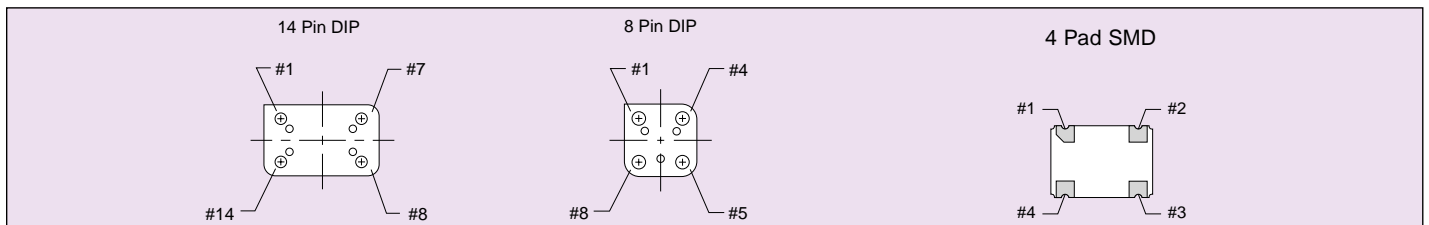

AVX/Kyocera Crystal Clock Oscillators

MECHANICAL

Readings to be made one hour after completion of test.

Shock Resistance - Drop module onto a hard wooden surface from a height of 50cm, three times. Unit must meet initial electrical requirements after test.

Vibration Resistance - Vibrations with an amplitude of 1.5mm and a sweep between 10 and 55Hz of 1 minute shall be applied for 2 hours in each of the X, Y, and Z axes for a total test time of 6 hours. Unit must meet initial electrical requirements after test.

Pin Pull and Bend - A load of 1kg shall be applied for 30 seconds in the direction of each pin. The pin will withstand without damage a bend from its base of 90° in one direction twice. Unit must meet initial electrical requirements after test.

Solvent Resistance - After immersion in Freon TF, Freon TE or IPA Liquid, at 25±5°C for a period of 10 minutes, unit shall meet initial electrical requirements.

Ultrasonic Resistance - Unit shall withstand ultrasonic washing at 28 to 31kHz and 300 watts per 20 liters of fluid in either Freon TF, Freon TE or IPA for up to 30 seconds without damage.

ENVIRONMENTAL

Readings to be made two hours after completion of test.

Soldering Heat - Immerse pin to within 1mm of the glass stand-off in a solder bath of 280±10°C for 10 seconds. Unit shall meet initial electrical requirements after test.

Heat Resistance - After exposure to +85°C for 500 hours, frequency change shall be within ±10ppm of initial value.

Cold Resistance - After exposure to -40°C for 500 hours, unit must meet initial electrical requirements.

Humidity Resistance - After exposure to +85°C and 85% RH for 500 hours, unit must meet initial electrical requirements and show no significant rusting.

Thermal Shock - After 15 cycles of immersions in baths of 100°C and 0°C for 5 minutes with transfer times within 10 seconds, units will meet initial electrical requirements.

Hermeticity - Helium leak detector test should be performed under 5×10^{-7} atm, and measured after application of 10kg/sq cm of pressure for three hours and exposure to air for 30 minutes. No air bubbles shall be found when immersed in 75°C water for 5 minutes.

AVX/Kyocera Crystal Clock Oscillator



K50-HC-C Series Miniature SMT Crystal Clock Oscillators

HCMOS Compatible

f_o : 8 to 68 MHz

Features:

- 1) Miniature SMT ceramic package
- 2) Frequency: 8~68MHz
- 3) Stability: 100ppm, 50ppm
- 4) Load: 50pF maximum
- 5) Tristate output inhibit
- 6) Hermetically sealed package
- 7) 1000 pieces per reel
- 8) Sold in increments of 1000 pieces

How to Order

K50-HC 1 CS E 40.0000M R

- ① ② ③ ④ ⑤ ⑥

- ① Type: (K50-HC series)
- ② Stability: 1-100ppm, 0-50ppm
- ③ Output compatibility:
CS = CMOS 45/55 duty cycle @ 50% V_{DD}
CS = TTL 40/60 duty cycle @ 1.4 volts
- ④ Tristate output: E with function
- ⑤ Frequency (MHz)
- ⑥ Packaging: R=Tape and reel

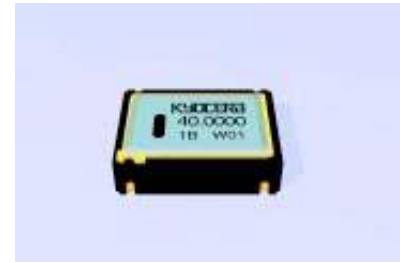

SPECIFICATIONS (K50-HC)

| Parameters | Code | TTL Output | | CMOS Output | | Unit |
|---------------------|--------------|---|---------------------------------|---|---------------------------------|-------|
| | | Rating | Remarks | Rating | Remarks | |
| Output Frequency | f_{OUT} | 8~68 | | 8~68 | | MHz |
| Frequency precision | $\Delta f/f$ | 1=100, 0=50 | -10 to 70°C, $V_{DD}=5\pm 0.5V$ | 1=100, 0=50 | -10 to 70°C, $V_{DD}=5\pm 0.5V$ | ppm |
| Operating temp. | t_{OPR} | -10 to +70 | | -10 to +70 | | °C |
| Storage temp. | t_{STOR} | -55 to +125 | | -55 to +125 | | °C |
| Supply voltage | V_{DD} | 5 ±0.5 | | 5 ±0.5 | | V |
| Supply current | I_{DD} | 40 max @ 10TTL/15pF | 25°C, 50MHz | 50 max @ 50pF | 25°C, 50MHz | mA |
| Duty cycle | S_Y | 40/60 | at 1.4 volts | 45/55 | @50% V_{DD} | % |
| Output "0" level | V_{OL} | 0.4max | @ $I_{OL} = 16mA$ | 0.5max | @ $I_{OL} = 16mA$ | V |
| Output "1" level | V_{OH} | 2.4min | @ $I_{OH} = -1mA$ | $V_{DD}-0.5min$ | @ $I_{OH} = -1mA$ | V |
| Rise / Fall time | T_R/T_F | 5max | 0.4V-2.4V | 10max | 10-90% V_{DD} , 50pF | nS |
| Load | | $f_o \leq 50MHz = 50pF$ $f_o > 50MHz = 15pF$ | | $f_o \leq 50MHz = 50pF$ $f_o > 50MHz = 15pF$ | | |
| Enable/disable time | | 100max | | 100max | | nS |
| Aging rate | | ±5max | | ±5max | | ppm/y |
| Input voltage-high | V_{IH} | 2.2min | | 2.2min | | V |
| Input voltage-low | V_{IL} | 0.8max | | 0.8max | | V |

TEST CIRCUIT

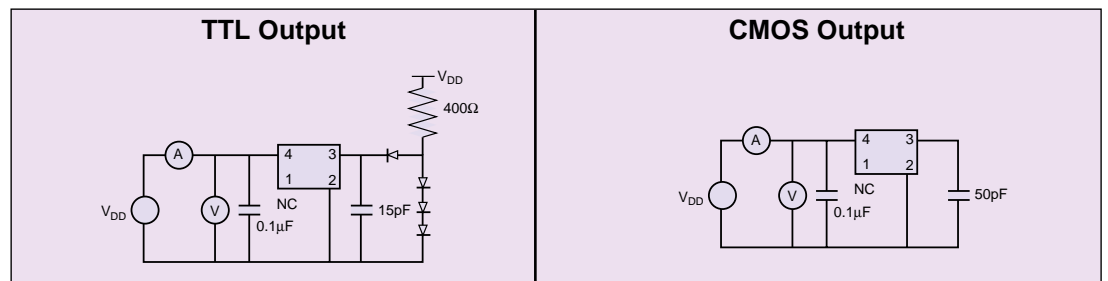

OUTPUT WAVEFORM

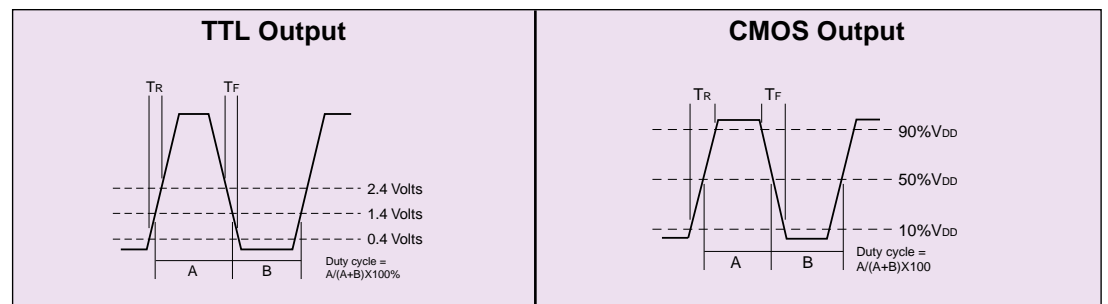

K50-3C Series Miniature SMT Crystal Clock Oscillators

3.3 Volt

f_o : 8 to 68 MHz

Features

- 1) 3.3 volt operation
- 2) Tristate output inhibit and oscillation shutdown to reduce power supply current draw
- 3) Miniature SMT ceramic package
- 4) Frequency: 8 to 68MHz
- 5) Stability: 100ppm
- 6) Load: up to 15pF
- 7) Hermetically sealed package
- 8) 1000 pieces per reel
- 9) Sold in increments of 1000 pieces

How to Order

K50-3C 1 E 40.0000M R

- ① Type: (K50-3C series)
 ② Stability: 1-100ppm
 ③ Tristate o/p and shutdown: E with function
 ④ Frequency (MHz)
 ⑤ Packaging: R=Tape and reel

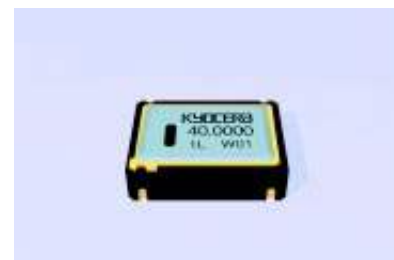

SPECIFICATIONS (K50-3C)

| Parameters | Code | Rating | Unit | Remarks |
|-------------------------------|-------------|------------------|---------|--|
| Output Frequency | f_{OUT} | 8 to 68 | MHz | |
| Frequency precision | $D_{F/F}$ | 1=100, 0=50 | ppm | -10 to 70°C, $V_{DD}=3.3\pm 10\%$ |
| Operating temp | t_{OPR} | -10 to +70 | °C | |
| Storage temp | t_{STOR} | -55 to +125 | °C | |
| Supply voltage | V_{DD} | 3.3 $\pm 10\%$ | V | |
| Supply current ₍₁₎ | $I_{DD(1)}$ | 25 max @ 15pF | mA | 25°C, 68MHz |
| Supply current ₍₂₎ | $I_{DD(2)}$ | 100 max | μA | Oscillation shutdown (pad #1= low, pad #3=high imp.) |
| Duty cycle | S_Y | 40/60 | % | @50% V_{DD} |
| Output "0" level | V_{OL} | 10% V_{DD} max | V | @15pF load |
| Output "1" level | V_{OH} | 90% V_{DD} min | V | @15pF load |
| Rise / Fall time | T_R/T_F | 10max | nS | 10%-90% V_{DD} , 15pF |
| Load | | 15max | pF | or 5LSTTL |
| Enable/disable time | | 5 | mS | 8.0000 to 32.0000MHz |
| | | 150max | nS | 32.0001 to 50.0000MHz |
| | | 5 | mS | 50.0001 to 68.0000MHz |
| Aging rate | | ± 5 max | ppm/y | |
| Input voltage-high | V_{IH} | 2.0min | V | $V_{DD} = 3.3V$, $I_{IH} = 10\mu A$ |
| Input voltage-low | V_{IL} | 0.5max | V | |

TEST CIRCUIT

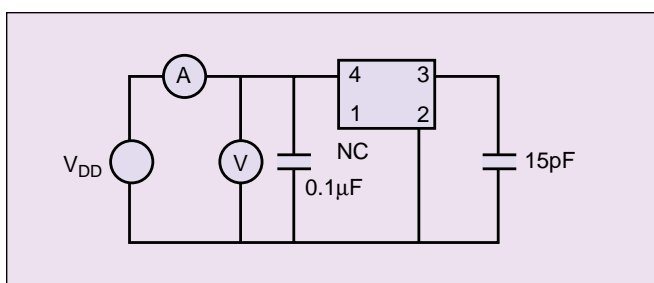

OUTPUT WAVEFORM

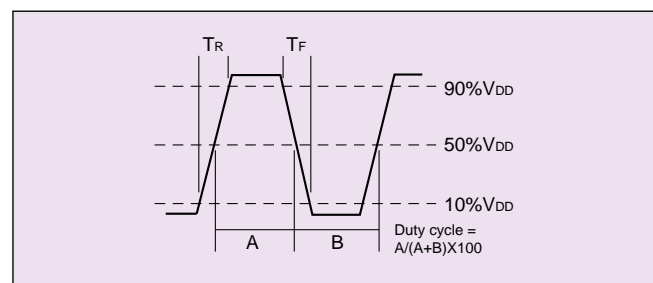

K50-CS Series Miniature SMT Crystal Clock Oscillators

Low Power Consumption

f_o : 8 to 50 MHz

Features

- 1) Miniature SMT ceramic package
- 2) Low power consumption
- 3) Frequency: 8-50MHz
- 4) Stability: 100ppm, 50ppm
- 5) Load: 15pF
- 6) Tristate output inhibit
- 7) Hermetically sealed package
- 8) 1000 pieces per reel
- 9) Sold in increments of 1000 pieces

How to Order

K50-CS 1 S E 40.0000M R

- ① ② ③ ④ ⑤ ⑥
- ① Type: (K50-CS series)
 - ② Stability: 1-100ppm, 0-50ppm
 - ③ Duty cycle: S-45/55
 - ④ Tristate o/p: E with function
 - ⑤ Frequency
 - ⑥ Packaging: R=Tape and reel

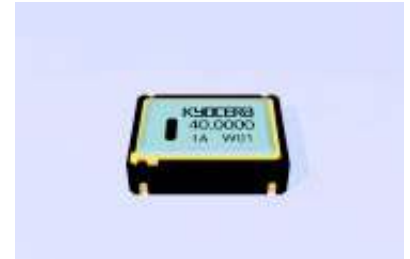

SPECIFICATIONS (K50-CS)

| Parameters | Code | Rating | Unit | Remarks |
|---------------------|--------------|-----------------|-------|---------------------------------|
| Output Frequency | f_{OUT} | 8 to 50 | MHz | |
| Frequency precision | $\Delta f/f$ | 1=100, 0=50 | ppm | -10 to 70°C, $V_{DD}=5\pm 0.5V$ |
| Operating temp | t_{OPR} | -10 to +70 | °C | |
| Storage temp | t_{STOR} | -55 to +125 | °C | |
| Supply voltage | V_{DD} | 5 ± 0.5 | V | |
| Supply current | I_{DD} | 30 max @ 15pF | mA | 25°C, 50MHz |
| Duty cycle | S_Y | 45/55 | % | @50% V_{DD} |
| Output "0" level | V_{OL} | $0.1V_{CC}$ max | V | @ $I_{OL} = 4.0mA$ |
| Output "1" level | V_{OH} | $0.9V_{CC}$ min | V | @ $I_{OH} = -4.0mA$ |
| Rise / Fall time | T_R/T_F | 10max | nS | $0.1V_{CC}-0.9V_{CC}$ |
| Load | | 15max | pF | |
| Enable/disable time | | 100max | nS | |
| Aging rate | | ± 5 max | ppm/y | |
| Input voltage-high | V_{IH} | 2.2min | V | |
| Input voltage-low | V_{IL} | 0.8max | V | |

TEST CIRCUIT

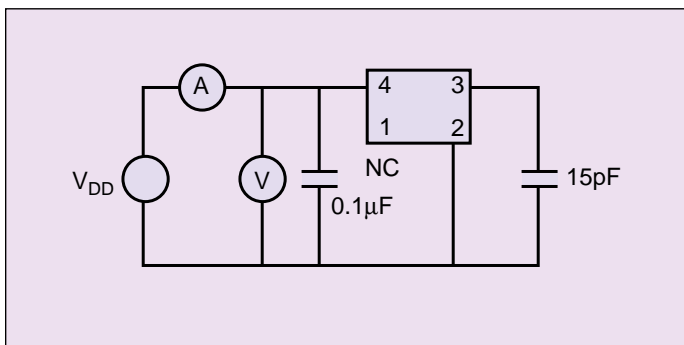

OUTPUT WAVEFORM

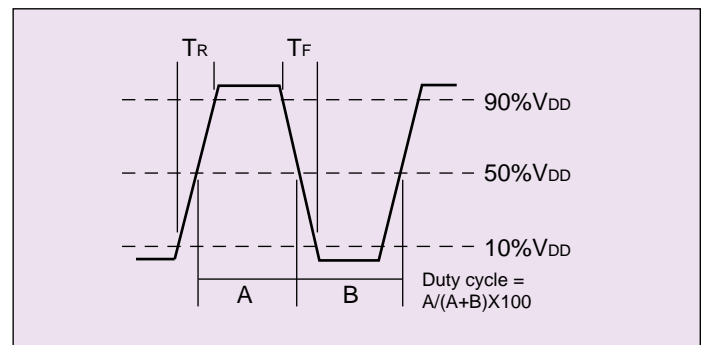

K50 Series Miniature SMT Clock Oscillators

Ceramic Package

DIMENSIONS

| Pad # | Function |
|-------|-----------------|
| 1 | Output Disable* |
| 2 | GND/ Case GND |
| 3 | Output |
| 4 | +VDD |

*Logic "0" disables o/p

*Marking: *1) 1 = 100ppm, 0 = 50ppm. *2) A = CS-E, B = HC-CSE, L = 3C-LE (3.3 volt)

Units: mm (inches)

SOLDERING

Suggested IR Reflow Profile

Suggested Solder Pad Layout

Units: mm (inches)

FREQUENCY VS. POWER SUPPLY CURRENT

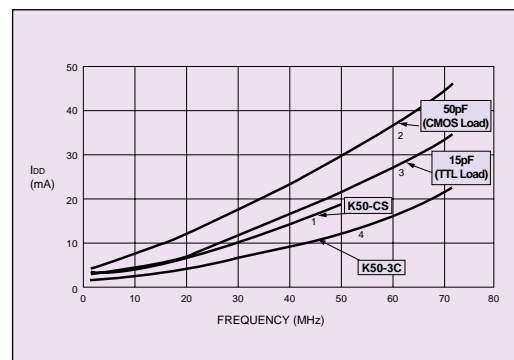

ENABLE/DISABLE FUNCTION CHART

| K50-HC-C, K50-CS Series | | K50-3C-L Series | |
|-------------------------|----------------|-----------------|-------------------------------------|
| #1 Pad | #3 Pad | #1 Pad | #3 Pad |
| High or Open | Oscillation | High | Oscillation |
| Low | High Impedance | Low | High Impedance Oscillation Stops |

PACKAGING

Reel Dimensions

Embossed Carrier Tape Dimensions

Units: mm (inches)

KT11 Series SMT Crystal Clock Oscillators

Temperature Compensated

FEATURES

- 1) Frequency adjustment free after reflow soldering process
- 2) Ultra miniature type (11X9X4mm)
- 3) AFC function available (option)
- 4) 3V/5V drive available
- 5) 1000 pieces per reel
- 6) Sold in increments of 1000 pieces

HOW TO ORDER

KT11 - E G R 30 N - 19.200M T

- ① ② ③ ④ ⑤ ⑥ ⑦ ⑧
- ① Type
 - ② Frequency precision: D=±2ppm, E=±2.5ppm, K=±5ppm
 - ③ Lower temperature limit: C=-30°C; E=-20°C, G=-10°C
 - ④ Upper temperature limit: R=60°C; T=70°C; V=80°C
 - ⑤ Supply voltage: 30=3.0V; 50=5.0V
 - ⑥ AFC function; V=with; N=without; L=with (trimmerless)
 - ⑦ Frequency: See table below.
 - ⑧ Packaging: T=Tape and reel



SPECIFICATIONS

| | | |
|--|------------------------------------|--|
| Frequency | 19.200MHz/PHS | 12.8, 13.0, 14.4, 14.85, 15.36, 15.9, 16.8MHz/Cellular |
| V_{DD} | 3V±5% | 3V or 5V±5% |
| Output (10k /10pF) | 1.0Vp-p min. | 1.0Vp-p min. |
| Current consumption (no load) | 2.0mA max. | 2.0mA max. |
| Frequency stability (Δf/fa) | Temperature | ±2.5ppm (-10~+60°C) |
| | Load (10pF/10kΩ ±10%) | ±0.2ppm max. (-30~+80°C) |
| | Voltage (3.0V ±5%) | ±0.3ppm max. |
| Trimmer adjustment (Δf/fa) | ±3.0ppm min. | ±3.0ppm min. |
| Voltage control (1.5V±1.0V)Δf/V | ±4~±8ppm (±30ppm:Trimmerless type) | ±4~±8ppm (±30ppm:Trimmerless type) |
| Spurious ratio | -3dBc max. | -3dBc max. |
| Aging | ±1.0ppm / y max. | ±1.0ppm / y max. |

TEST CIRCUIT (EXCEPT FOR HARMONIC)

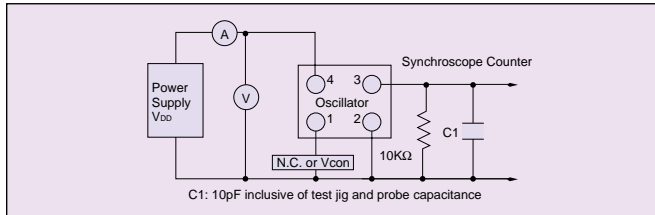

TEST CIRCUIT (HARMONIC)

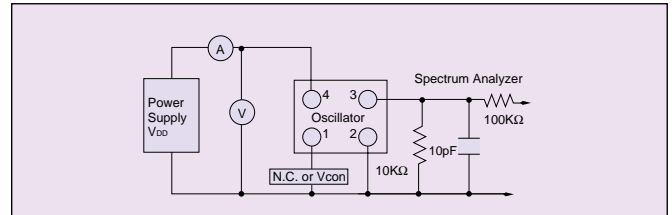

DIMENSIONS

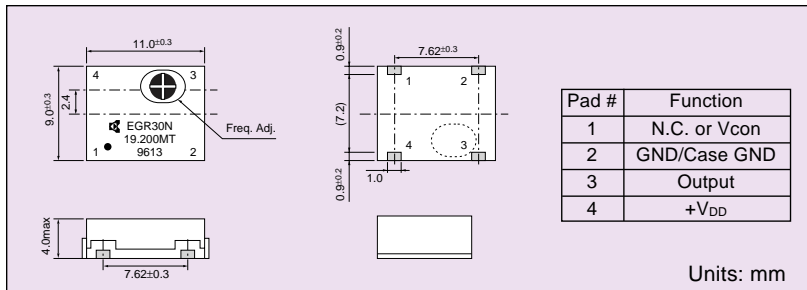

RECOMMENDED PAD LAYOUT

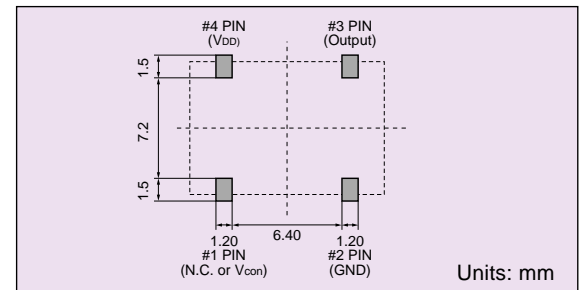

TAPING DIMENSIONS

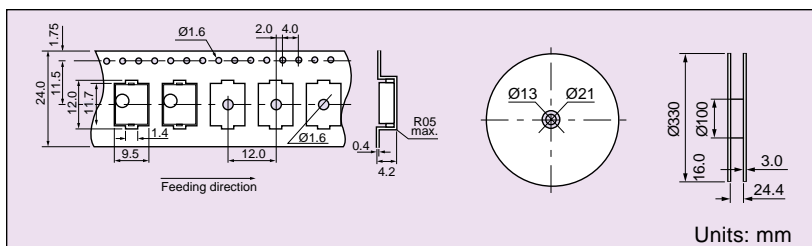

RECOMMENDED REFLOW PROFILE

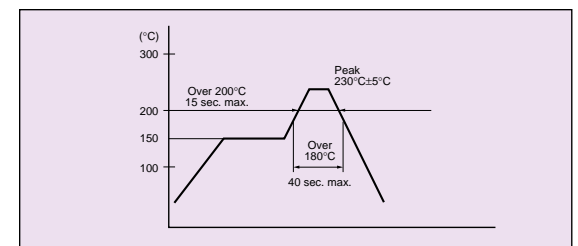

KT12 Series SMD Crystal Clock Oscillators

Temperature Compensated

FEATURES

- 1) Miniature SMD type (11.6x9.6x2.3mm)
- 2) Frequency adjustment free after reflow soldering process
- 3) AFC function available (option)
- 4) 3V/5V drive available
- 5) Frequency stability: ± 2 ppm at $-30 \sim +80^\circ\text{C}$
- 6) 2000 pieces per reel
- 7) Sold in increments of 2000 pieces

HOW TO ORDER

KT12 - **D C V 33 V** - **19.680M T**

- ① ② ③ ④ ⑤ ⑥ ⑦ ⑧ ⑨
- ① Type
 - ② Terminals: Blank ()=4 terminals, A=6 terminals, B=8 terminals
 - ③ Frequency stability: D= ± 2 ppm, E= ± 2.5 ppm, K= ± 5 ppm
 - ④ Lower operating temp.: C= -30°C ; E= -20°C , G= -10°C
 - ⑤ Upper operating temp.: R= 60°C ; T= 70°C ; V= 80°C
 - ⑥ Supply voltage: 30=3.0V; 50=5.0V
 - ⑦ AFC function; V=with; N=without; L=with (trimmerless)
 - ⑧ Frequency: See table below
 - ⑨ Packaging: T= Tape and reel



SPECIFICATIONS

| Parameters | Code | Specification | | Unit | Remarks |
|-----------------------|-------|----------------|---|------------------|---|
| | | PHS | Cellular | | |
| Supply Voltage | Vcc | 3.0V $\pm 5\%$ | 3.0V $\pm 5\%$ 5.0V $\pm 5\%$ | V | |
| Output Frequency | Fout | 19.200 | 19.680 19.200 16.800 14.400 13.000 12.800 | MHz | — |
| Operating Temp. | Topr | -10 ~ 60 | -30 ~ 80 max. | $^\circ\text{C}$ | — |
| Storage Temp. | Tstr | -20 ~ 70 | -40 ~ 85 | $^\circ\text{C}$ | — |
| Frequency Stability | f/fo | ± 2.5 max. | ± 2.0 max. ± 2.5 max. | ppm | vs. Temp. (After Reflow) vs. Load vs. Voltage |
| Aging Rate | Aging | | ± 1.0 max. | ppm/year | 1 Year |
| Output Voltage | Vout | | 1.0 min. | Vp-p | Load 10k /10pF |
| Supply Current | Icc | | 2.0 max. | mA | — |
| Trimmer Control Range | f/C | | ± 3.0 min. | ppm | Internal Trimmer |
| Voltage Control Range | f/V | | ex: $\pm 4.0 \sim \pm 8.0$ | ppm | 1.5V ± 1 V, 2.5 ± 1 V |
| Harmonics | — | | -3.0 max. | dBc | — |

DIMENSIONS

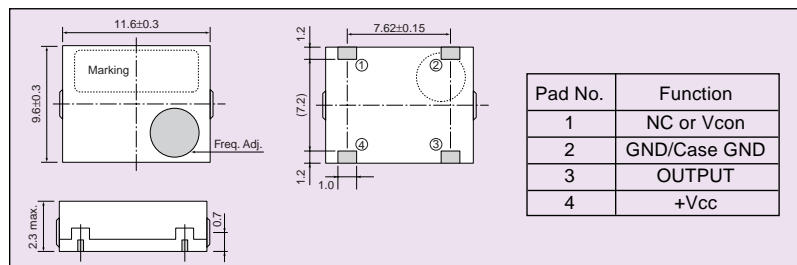

RECOMMENDED LAND PATTERN

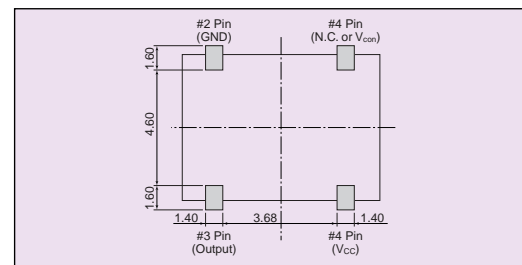

TEST CIRCUIT (AMPLITUDE)

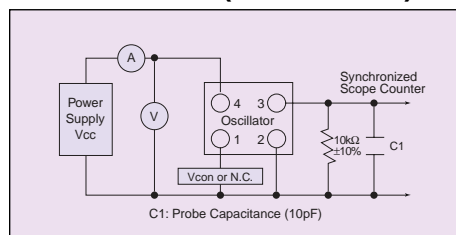

TEST CIRCUIT (HARMONICS & FREQUENCY)

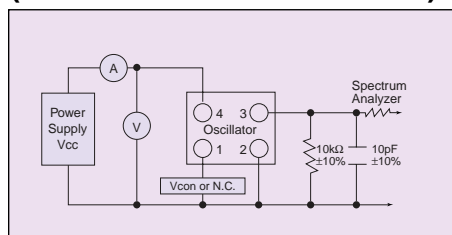

RECOMMENDED REFLOW PROFILE (IR REFLOW)

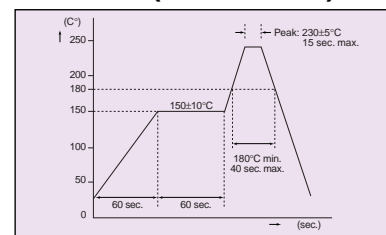

KT14 Series SMD Crystal Clock Oscillators

Temperature Compensated

FEATURES

- 1) Ultra low profile SMD type (9.0x7.0x1.7mm)
- 2) Frequency adjustment free after reflow soldering process
- 3) AFC function available (option)
- 4) 2.8, 3.0, 3.3V drive available
- 5) 2000 pieces per reel
- 6) Sold in increments of 2000 pieces

HOW TO ORDER

KT14 - E C T 28 L - 19.440 M T

- ① ② ③ ④ ⑤ ⑥ ⑦ ⑧
- ① Type
 - ② Frequency stability: D=±2ppm, E=±2.5ppm, K=±5ppm
 - ③ Lower operating temp.: C=-30°C; E=-20°C, G=-10°C
 - ④ Upper operating temp.: R=60°C; T=70°C; V=80°C
 - ⑤ Supply voltage: 28=2.8V; 50=3.0V
 - ⑥ AFC function; V=with; N=without; L=with (trimmerless)
 - ⑦ Frequency: See table below.
 - ⑧ Packaging: T=Tape and reel



SPECIFICATIONS

| Parameters | Code | Specification | | Unit | Remarks | |
|-----------------------|-------|---------------|------------------|----------|----------------|--------------------------|
| | | PHS | Cellular | | | |
| Supply voltage | Vcc | 2.8V±5% | 2.8V±5% | V | — | |
| | | | 3.0V±5% | | | |
| | | | 3.3V±5% | | | |
| Output Frequency | Fout | 19.200 | 13.000 | 14.400 | MHz | — |
| | | | 14.850 | 16.800 | | |
| | | | 19.200 | 19.440 | | |
| | | | 19.680 | 19.800 | | |
| Operating Temp. | Topr | -10 ~ 60 | -30 ~ 80 max. | | °C | — |
| Storage Temp. | Tstr | -20 ~ 70 | -40 ~ 85 | | °C | — |
| Frequency Stability | f/fo | ±2.5 max. | ±2.0 max. | | ppm | vs. Temp. (After Reflow) |
| | | | ±2.5 max. | | | |
| | | | ±0.2 max. | | | |
| | | | ±0.3 max. | | | vs. Load |
| | | | | | | vs. Voltage |
| Aging Rate | Aging | ±1.0 max. | | ppm/year | 1 Year | |
| Output Voltage | Vout | 1.0 min. | | Vp-p | Load 10K /10pF | |
| Supply Current | Icc | 2.0 max. | | mA | No Load | |
| Trimmer Control Range | f/C | ±3.0 min. | — | | ppm | — |
| Voltage Control Range | f/V | — | ex: ±8.0 ~ ±15.0 | | ppm | 1.5V±1V, 2.5±1V |
| Harmonics | — | -3.0 max. | | dBc | — | |

DIMENSIONS

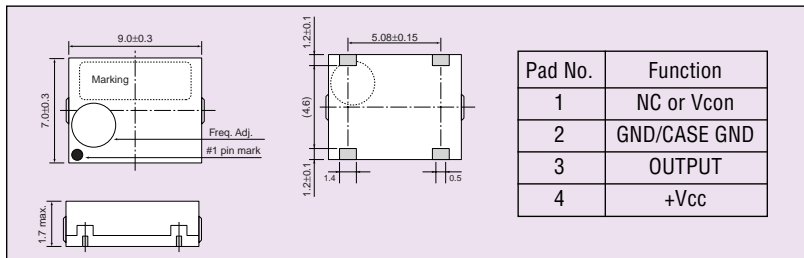

RECOMMENDED LAND PATTERN

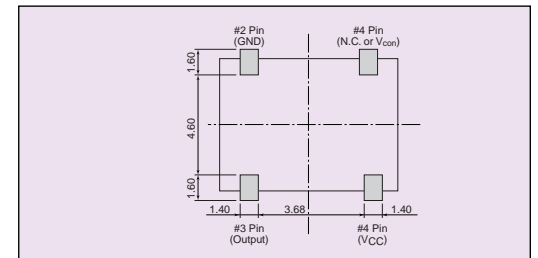

TEST CIRCUIT (AMPLITUDE)

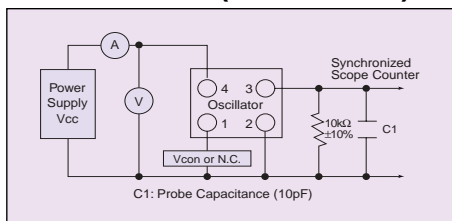

TEST CIRCUIT (HARMONICS & FREQUENCY)

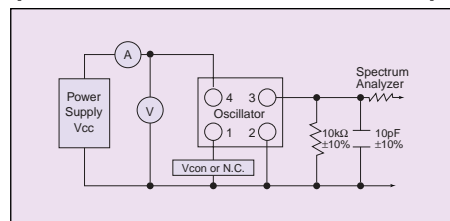

RECOMMENDED REFLOW PROFILE (IR REFLOW)

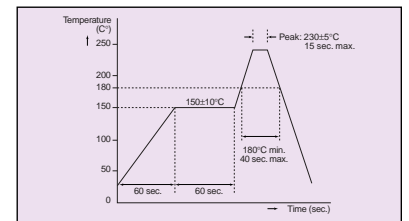

Voltage Control Oscillator

VK Series - Surface Mount

f_o : 100 to 700 MHz

FEATURES

- 1) Covers UHF band
- 2) For PDC mixing and PHS 2nd local
- 3) Available 2.2V, 3mA typ.
- 4) Small (9x7mm)
- 5) Low profile (2.00mm max.)
- 6) 2000 pieces per reel
- 7) Sold in increments of 2000 pieces

HOW TO ORDER

VK - 120 R 0130 A1 W

- ① ② ③ ④ ⑤ ⑥
- ① Series: VK=100~700MHz
 - ② Dimensions: 120=9x7mm
 - ③ Applications: R=RX
 - ④ Frequency: 0130=130MHz
 - ⑤ Individual specification
 - ⑥ Packaging: W = Tape and reel



SPECIFICATIONS

| Parameters | Specifications | Unit | Condition |
|----------------------------|----------------|-------|---|
| Supply Voltage | 2.2±0.2 | V | — |
| Current Consumption | 4.0 | mA | Ta=25±5°C Vcc=2.2±0.05[V] |
| Frequency | 129.545 | MHz | Vt=0.5 ~ 2.5V |
| Output Level | -3±3 | dBm | Ta=25±5°C Vcc=2.2±0.05[V] |
| Tuning Voltage Sensitivity | 2.5±1.0 | MHz/V | [f(2.5) - f(0.5)]/2.0 |
| C/N (Phase Noise) | 70 | dBc | off-set 25kHz 16kHz B.W. |
| PSU Stability | ±200 | kHz | Vcc=2.2V ±0.2V |
| Temperature Stability | ±1 | MHz | -20 ~ +70°C @25°C |
| Pulling Stability | ±200 | kHz | VSWR=2 All phase |
| Spurious Level | -10 | dBc | Reference is fundamental, Harmonics Level |
| Operating Temp. Range | -20 ~ 70 | °C | — |

DIMENSIONS and PAD CONNECTION

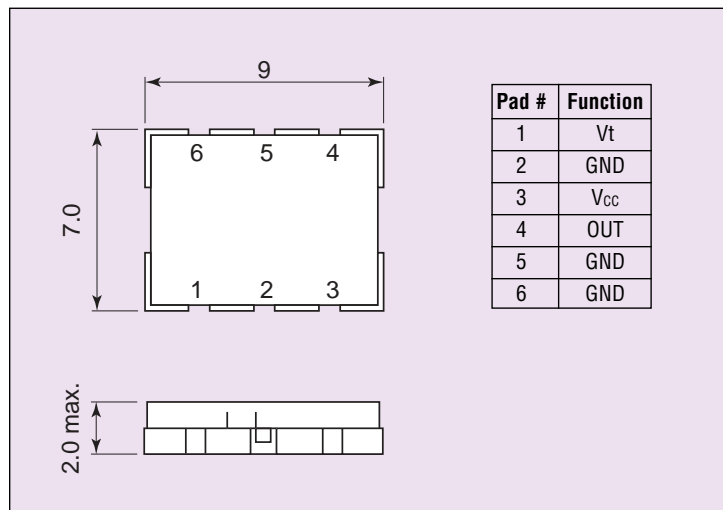

RECOMMENDED LAND PATTERN

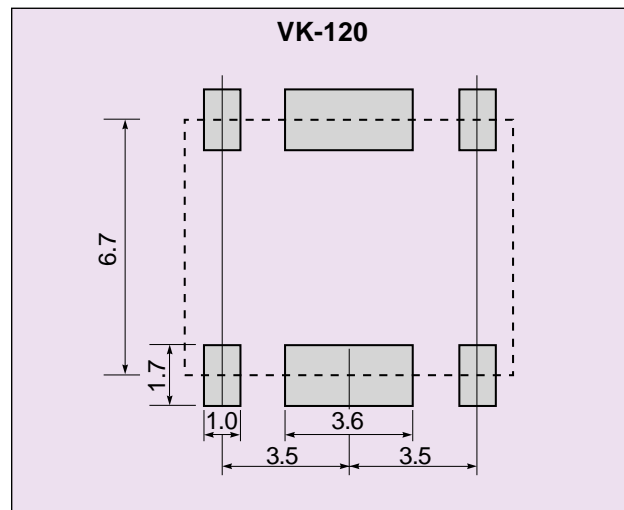

Voltage Control Oscillator

EK Series - Surface Mount

f_o : 700 to 1300 MHz

FEATURES

- 1) High reliability construction
- 2) Reflow soldering available
- 3) High performance for C/N and S/N
- 4) 2000 pieces per reel
- 5) Sold in increments of 2000 pieces

HOW TO ORDER

EK - 304 R 0972 AA W

- ① ② ③ ④ ⑤ ⑥
- ① Series: EK=700~1300MHz
 - ② Dimensions
 - ③ Applications: R=RX
 - ④ Frequency: 0927=927MHz
 - ⑤ Individual specification
 - ⑥ Packaging: W = Tape and reel

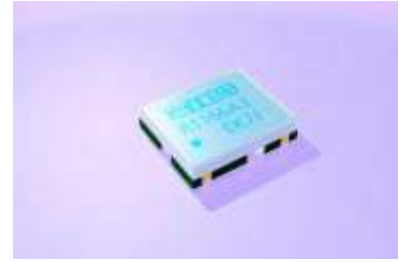

SPECIFICATIONS

| Type | | Frequency (MHz) | Part No. | Specifications (Ta=25°C) | | | | | |
|--------|--------|-----------------|---------------|--------------------------|----------------------|----------------------|-------------------------|-------------------------------|----------------------|
| System | Module | | | V _{cc} (V) | I _{cc} (mA) | P _o (DBM) | F _{TU} (MHZ/V) | C/N (dBc) | T _{OP} (°C) |
| N-TACS | RX | 765 ~ 800 | EK-304R0783A1 | 3 ±0.2 | 9 max. | -1±3 | 23±3 | 65 min. (12.5kHz off BW 8kHz) | -20 ~ 70 |
| PDC | | 1069~ 1090 | EK-304R1080A1 | 2.2 ±0.2 | 6 max. | -3±3 | 25±3 | 70 min. (50kHz off BW21kHz) | -20~ 80 |
| AMPS | | 914~939 | EK-304R0927A9 | 2.55 ±0.05 | 12 max. | +3±2 | 14±2 | 108 min. (20kHz off) | -30~ 85 |
| PCS | | 1310 ~ 1393 | EK-304R1352A2 | 2.8 ±0.1 | 10 max. | -6 min. | 39±4 | 100 min. (25kHz off) | -10 ~ 75 |
| GSM | | 1006~ 1031 | EK-304R1019A6 | | | | 15±3 | | -20~ 75 |
| PDC | | 780 ~ 841 | EK-304R0811A1 | 2.2 ±0.2 | 8 max. | -1±3 | 46±7 | 67 min. (50kHz off 21kHz BW) | -30 ~ 85 |

V_{cc}: Power supply, I_{cc}: Current consumption, P_o: Output level, F_{TU}: Tuning voltage sensitivity, T_{OP}: Operating temperature range

DIMENSIONS and PAD CONNECTION

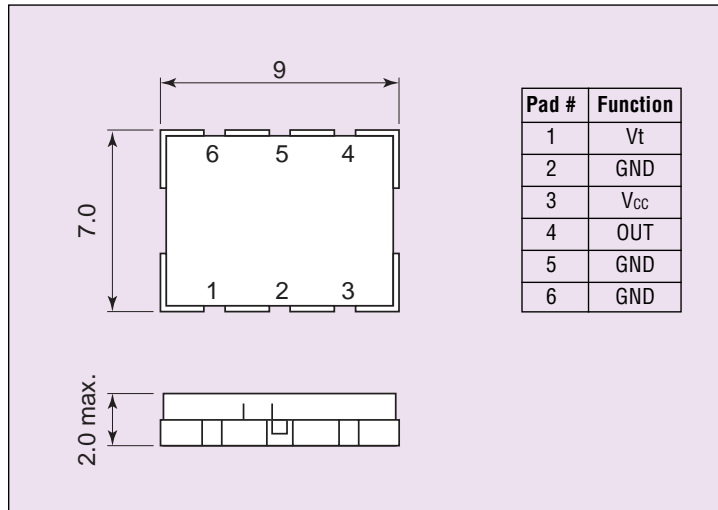

RECOMMENDED LAND PATTERN

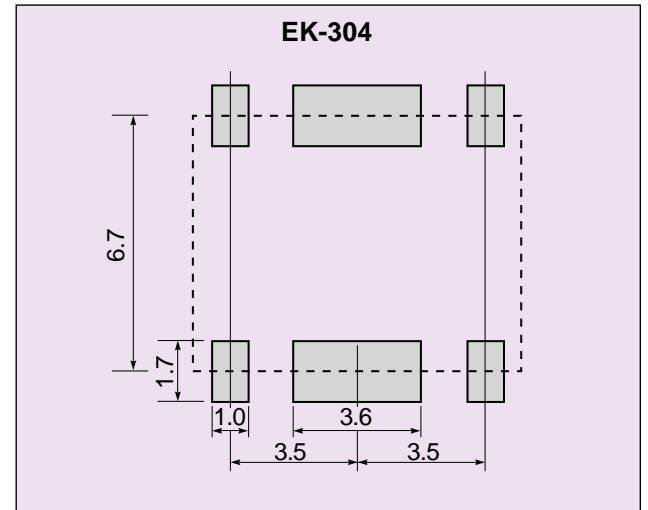

Voltage Control Oscillator

YK Series - Surface Mount

f_o : 700 to 1600 MHz

FEATURES

- 1) SMD type
- 2) Covers 700~1600Mhz band
- 3) Small (7.8X6.0mm),
Low Profile (2.00mm max.)
- 4) 2000 pieces per reel
- 5) Sold in increments of 2000 pieces

HOW TO ORDER

YK - 501 R 1171 A1 W

- ① ② ③ ④ ⑤ ⑥
- ① Series: YK=700~1600MHz
 - ② Dimensions
 - ③ Applications: R=RX
 - ④ Frequency: 1171=1171MHz
 - ⑤ Individual specification
 - ⑥ Packaging: W=Tape and reel



ELECTRICAL CHARACTERISTICS

| Parameters | Specifications | Unit | Condition |
|----------------------------|----------------|--------|---------------------------|
| Supply Voltage | 2.6±0.1 | V | — |
| Current Consumption | 8.0 | mA | Ta=25±5°C Vcc=2.5±0.05[V] |
| Frequency | 1136 ~ 1206 | MHz | Vt=0.3 ~ 2.4[V] |
| Output Level | -6 | dBm | Ta=25±5°C Vcc=2.5±0.05[V] |
| Tuning Voltage Sensitivity | 46±7 | MHz/V | [f(2.4)-f(0.3)] / 2.1 |
| C/N (Phase Noise) | 98 | dBc/Hz | off set 25kHz 1Hz B.W. |
| PSU Stability | ±1000 | kHz | Vcc=2.6V ±0.1V |
| Temperature Stability | ±3 | MHz | -10 ~ 60°C ref 25°C |
| Pulling Stability | ±1.5 | MHz | VSWR=2 All Phase |
| Spurious Level | -10 | dBc | Reference is fundamental |
| Operating Temp Range | -10 ~ 60 | °C | — |

*Covering frequency range is between 700MHz ~ 1600MHz

DIMENSIONS and PAD CONNECTION

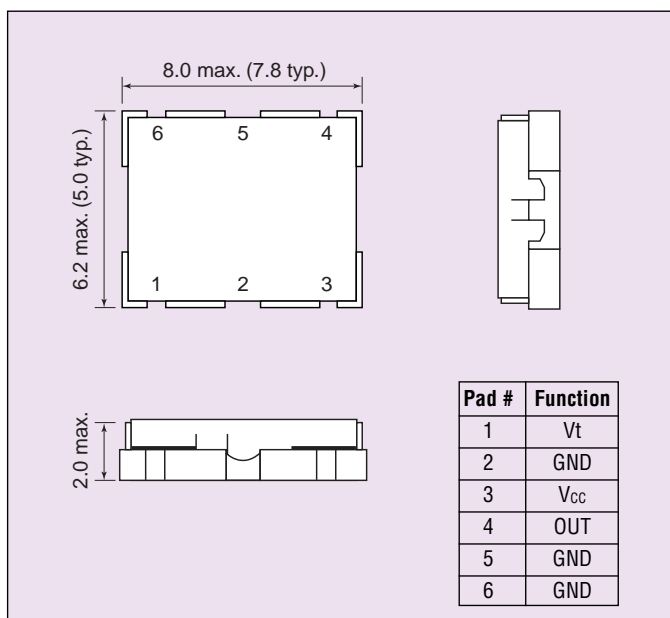

RECOMMENDED LAND PATTERN

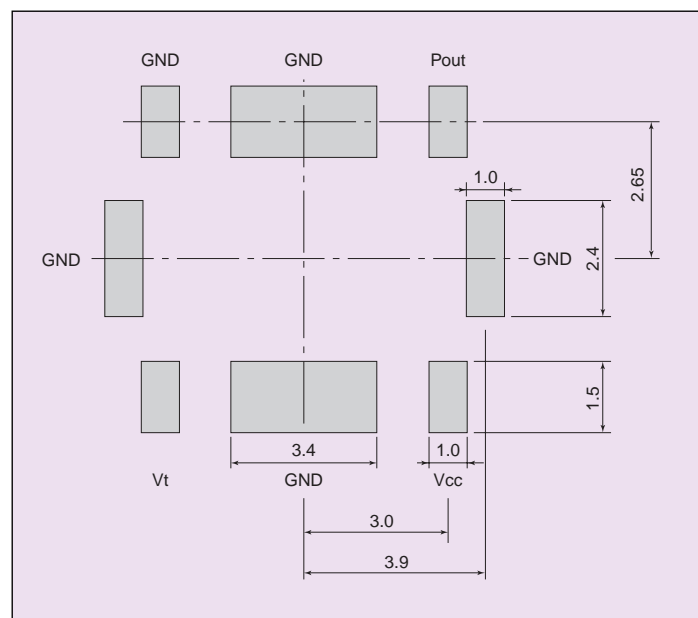

Voltage Control Oscillator

RK Series - Surface Mount

f_o : 1.3 to 2.0 GHz

FEATURES

- 1) Ultraminiature size based on low temperature co-firable laminated substrate technology
- 2) Printed conductive line on inner layer contributes to ultra high density mounting
- 3) Reflow soldering available
- 4) 2000 pieces per reel
- 5) Sold in increments of 2000 pieces

HOW TO ORDER

RK - 405 R 1668 A1 W

- ① ② ③ ④ ⑤ ⑥
- ① Series: RK=1300~2000MHz
 - ② Dimensions
 - ③ Applications: R=RX
 - ④ Frequency: 1668=1668Mhz
 - ⑤ Individual specification
 - ⑥ Packaging: W=Tape and reel



ELECTRICAL CHARACTERISTICS

| Type | | Frequency (MHz) | Part No. | Specifications (Ta=25°C) | | | | | | |
|--------|--------|-----------------|-------------|--------------------------|-------------|----------|-------------------------|--------------------------|-----|---------------------|
| System | Module | | | Vcc (V) | Icc (mA) | Po (dBm) | f _{tu} (MHz/V) | C/N | | Top (°C) |
| | | | | | | | | Min | Typ | |
| PHS | RX | 1647 ~ 1669 | RK-405R1658 | 3.0 ±0.15 | 6.5 max. | -1±3 | 24±5 Vt=0.5 ~ 2.5V | 123 min (600kHz off) | 128 | -20°C ~ +60°C |
| PHS | RX | 1651 ~ 1685 | RK-405R1668 | 3.0 ±0.15 | 6.5 max. | -1±3 | 31±6 Vt=0.5 ~ 2.5V | 123 min. (600kHz off) | 127 | -20°C ~ +60°C |

Vcc: Power supply, Icc: current consumption, Po: Output level, f_{tu}: tuning voltage sensitivity, Top: Operation temperature

DIMENSIONS and PAD CONNECTION

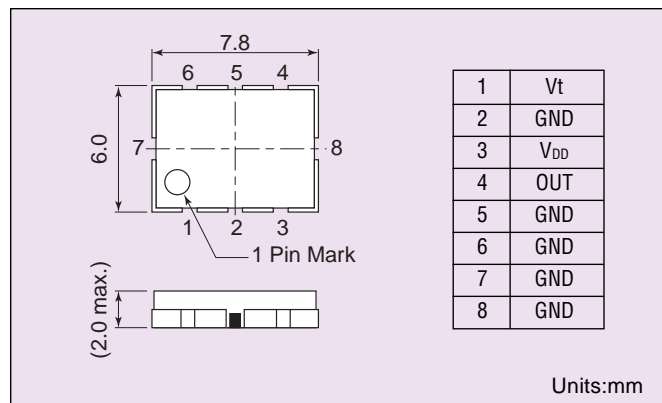

RECOMMENDED LAND PATTERN

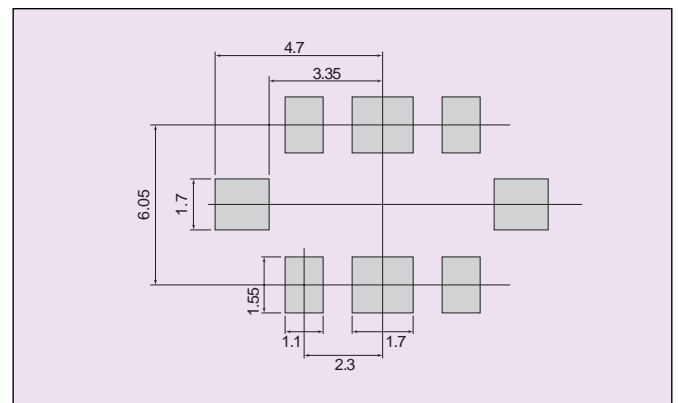

Voltage Control Oscillator

TAPE DIMENSIONS

| Part No. | Specifications | | |
|----------|-------------------------|------------------|---------|
| | Tape width, guide pitch | Diameter of Reel | Unit |
| VK-120 | | Ø 330 | 2000pcs |
| EK-304 | | Ø 330 | 2000pcs |
| YK-501 | | Ø 330 | 2000pcs |
| RK-405 | | Ø 330 | 2000pcs |

REEL DIMENSIONS

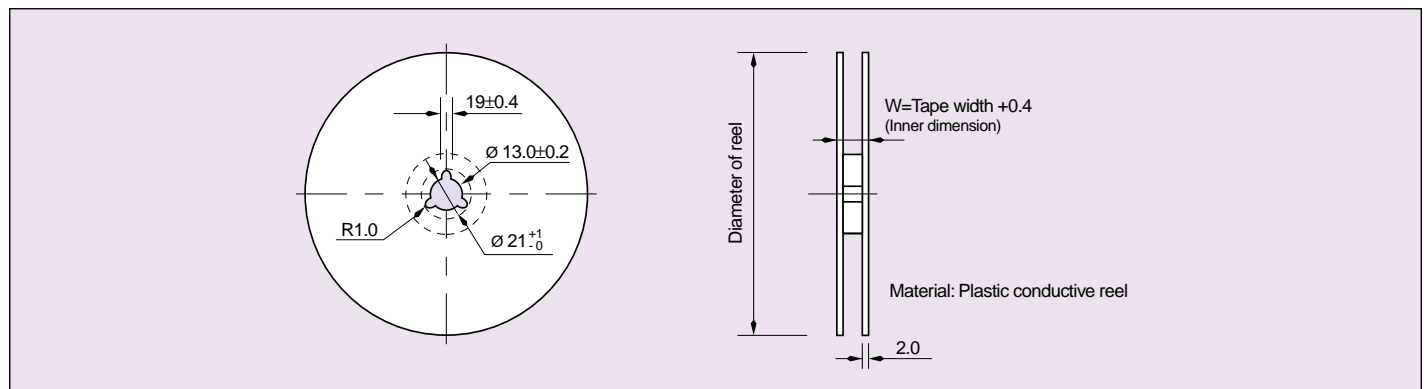

KXO-01 Series Crystal Clock Oscillators

TTL Drive - TTL Compatible

f_o : 8.0 to 50 MHz

FEATURES

- 1) Lower Cost
- 2) 14 pin DIP compatible
- 3) Wide frequency range (8MHz - 50MHz)
- 4) All metal package minimizes RF radiation
- 5) Meets FCC EMI specifications
- 6) Solder coated pins
- 7) 25 pieces per tube
- 8) Sold in increments of 100 pieces

HOW TO ORDER

KXO-01 - 1 - 32.0000M T

① ② ③ ④

- ① Type: (Kyocera Crystal Oscillators)
- ② Frequency precision:
0 = ± 50 ppm (special)
1 = ± 100 ppm
- ③ Frequency
- ④ Packaging: T = Tube

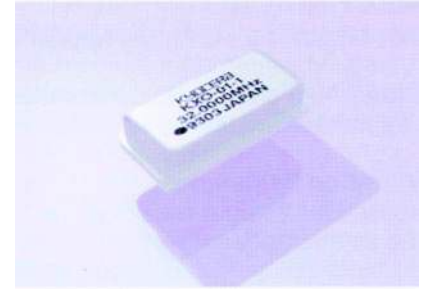

SPECIFICATIONS (KXO-01)

| Parameters | | Code | Rating | Unit | Remarks |
|--------------------------------|--------------------|----------------|---------------|---------------|----------------------|
| Output Frequency | | f_{out} | 8 to 50 | MHz | |
| Frequency Precision | | $\Delta f/f_o$ | 0: ± 50 | ppm | 0 to 70°C |
| | | | 1: ± 100 | ppm | 4.5V to 5.5V |
| Aging Rate | | $\Delta f/f$ | ± 5 | ppm/y | |
| Operating Temperature Range | | T_{opr} | 0 to ± 70 | °C | |
| Storage Temperature Range | | | -55 to +125 | °C | |
| Voltage | | V_{DD} | 5 \pm 0.5 | VDC | |
| Electrical Current Consumption | | I_{DD} | 35 max | mA | |
| Output | Duty Ratio | S_y | 40 to 60 | % | 1.4V DC level |
| | "0" Level | V_{OL} | 0.4 max | V | At $I_{OL}=16$ mA |
| | "1" Level | V_{OH} | 2.4 min | V | At $I_{OH}=400\mu$ A |
| | Rise and Fall Time | T_R, T_F | 15 max | nsec | 8 to 32MHz |
| 10 max | | | nsec | 32.1 to 50MHz | |
| Fan Out | | | 1 to 10 | TTL | |

DIMENSIONS

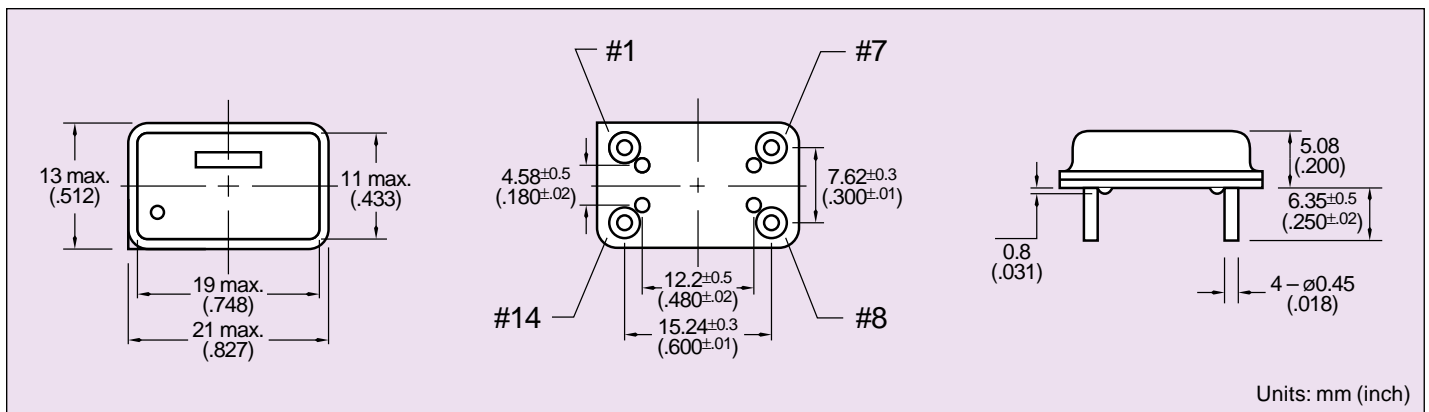

KXO-01 Series Crystal Clock Oscillators

TTL Drive - TTL Compatible

f_o : 8.0 to 50 MHz

MARKING

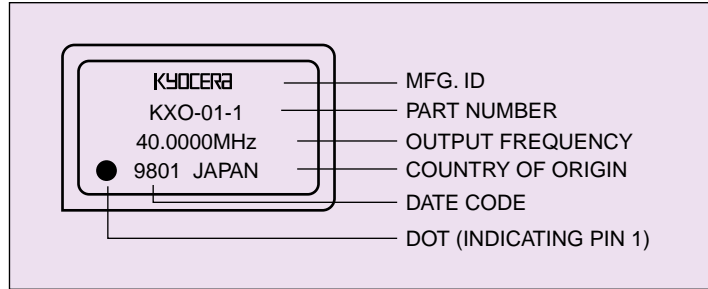

PIN CONNECTION

| PIN # | FUNCTION |
|-------|------------|
| 1 | N.C. |
| 7 | Case /GND |
| 8 | Output |
| 14 | +5.0V D.C. |

POPULAR FREQUENCY LIST

| | | |
|-------------|------------|------------|
| 8.0000MHz | 16.0000MHz | 25.0000MHz |
| 10.0000MHz | 19.6608MHz | 32.0000MHz |
| 12.0000MHz | 20.0000MHz | 40.0000MHz |
| 14.31818MHz | 24.0000MHz | 50.0000MHz |

TEST CIRCUIT

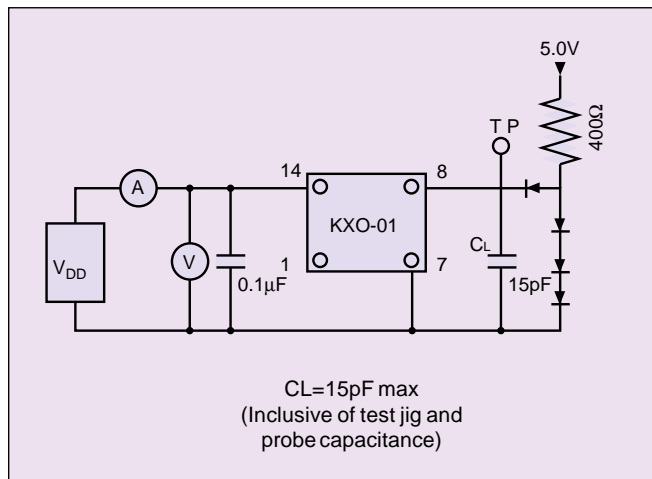

SHAPE OF OUTPUT WAVE

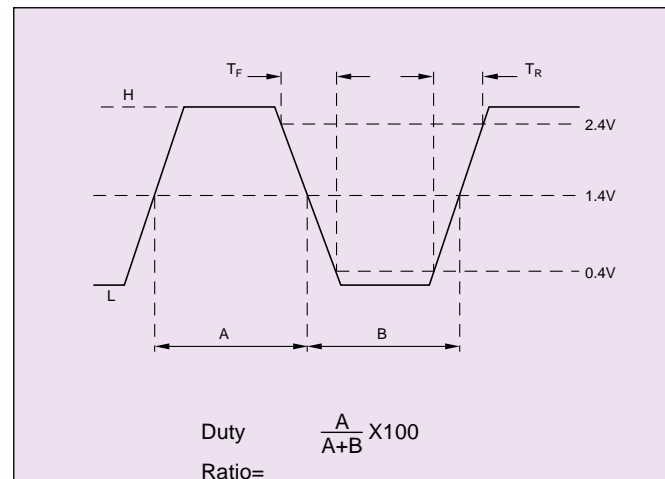

KXO-HC/KHO-HC Series Crystal Clock Oscillators

HCMOS Drive - TTL or CMOS Compatible

f_o : 1 to 72 MHz

FEATURES

- 1) High speed CMOS clock oscillator
- 2) High power drive level
- 3) Low current consumption
- 4) Output available with TTL or CMOS compatibility
- 5) Enable/disable option
- 6) KHO-HC: 8 pin DIP
- 7) KXO-HC: 14 pin DIP
- 8) KXO: 25 pieces per tube
KHO: 40 pieces per tube
- 9) KXO: Sold in increments of 100 pieces
KHO: Sold in increments of 120 pieces

HOW TO ORDER

KXO-HC 1 - T S E - 32.0000M T

- ① ② ③ ④ ⑤ ⑥
- ① Type: KXO = 14 pin DIP; KHO = 8 pin DIP
 - ② Frequency precision:
S = ± 25 ppm, 0 = ± 50 ppm, 1 = ± 100 ppm
 - ③ Output level/Duty cycle:
TS = TTL compatible/45 to 55%
CS = CMOS compatible/45 to 55%
 - ④ Enable/Disable function:
 = without function, E = with function
 - ⑤ Frequency
 - ⑥ Packaging: T = Tube



SPECIFICATIONS: TTL COMPATIBLE (KXO-HC-T/KHO-HC-T)

| Parameters | | Code | Rating | | Unit | Remarks |
|--------------------------------|--------------------|----------------------|--|--|--------------------|--|
| Output Frequency | | f_{OUT} | 1 to 50 | >50 | MHz | |
| Frequency Precision | | f/f_o | S: ± 25 0: ± 50 1: ± 100 | S: ± 25 0: ± 50 1: ± 100 | ppm ppm ppm | 0 to 70°C 4.5V to 5.5V |
| Operating Temperature Range | | T_{OPR} | 0 to +70 | 0 to +70 | °C | |
| Storage Temperature | | T_{str} | -55~+125 | -55~+125 | °C | |
| Voltage | | V_{DD} | 5 ± 0.5 | 5 ± 0.25 | V | |
| Electrical Current Consumption | | I_{DD} | 50 max | 70 max | mA | $f=50$ MHz, $C_L=15$ pF (10TTL load) |
| Output | Duty Cycle | S_Y | 45 to 55 | 45 to 55 | % | 1.4V DC level |
| | "0" Level | V_{OL} | 0.4 max | 0.4 max | V | At $I_{OL}=16$ mA |
| | "1" Level | V_{OH} | 2.4 min | 2.4 min | V | At $I_{OH}=-1$ mA |
| | Rise and Fall Time | T_R, T_F | 5.0 max | 3.5 max | nsec | 0.4V to 2.4V, $C_L=15$ pF (10TTL load) |
| Fan Out | | | TTL 10 gates | TTL 10 gates | | CMOS level OK |
| Time to Enable/Disable | | | 100 max | 100 max | nsec | Tristate output |
| Input Current | | I_{IH} I_{IL} | 10 max -150 max | 10 max -150 max | μ A μ A | |
| Input Voltage | | V_{IH} V_{IL} | 2.2 min 0.8 max | 2.2 min 0.8 max | V V | |
| Aging | | f/f | ± 5 | ± 5 | ppm/yr | |

TEST CIRCUIT

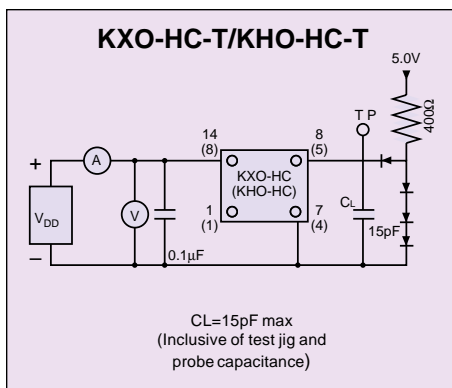

SHAPE OF OUTPUT WAVE

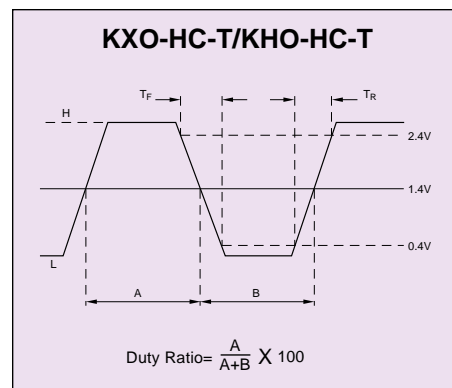

MARKINGS

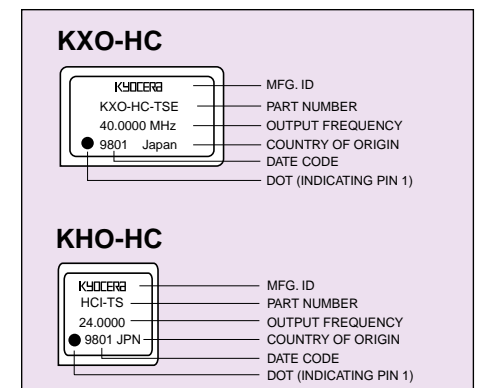

KXO-HC/KHO-HC Series Crystal Clock Oscillators

HCMOS Drive - TTL or CMOS Compatible

f_o : 1 to 72 MHz

SPECIFICATIONS: CMOS COMPATIBLE (KXO-HC-C/KHO-HC-C)

| Parameters | | Code | Rating | | Unit | Remarks |
|--------------------------------|--------------------|------------|--------------------------|--------------------------|-------------------|--|
| Output Frequency | | f_{OUT} | 1 to 50 | >50 | MHz | |
| Frequency Precision | | f/f_o | S:±25 0:±50 1:±100 | S:±25 0:±50 1:±100 | ppm ppm ppm | 0 to 70°C 4.5V to 5.5V |
| Operating Temperature Range | | T_{OPR} | 0 to +70 | 0 to +70 | °C | |
| Storage Temperature Range | | T_{str} | -55~+125 | -55~+125 | °C | |
| Voltage | | V_{DD} | 5±0.5 | 5±0.25 | V | |
| Electrical Current Consumption | | I_{DD} | 50 max | 80 max | mA | $f > 50\text{MHz}$, $C_L = 15\text{pF}$ $f < 50\text{MHz}$, $C_L = 50\text{pF}$ |
| Output | Duty Cycle | S_Y | 45 to 55 | 45 to 55 | % | 1/2 V_{DD} level |
| | "0" Level | V_{OL} | 0.1 V_{DD} max | 0.1 V_{DD} max | V | At $I_{OL} = 16\text{mA}$ |
| | "1" Level | V_{OH} | 0.9 V_{DD} min | 0.9 V_{DD} min | V | At $I_{OH} = -1\text{mA}$ |
| | Rise and Fall Time | T_R, T_F | 10 max | 6 max | nsec | 10% V_{DD} to 90% V_{DD} $C_L = 50\text{pF}$ |
| Time to Enable Disable | | | 100 max | 100 max | nsec | Tristate Output |
| Input Current | | I_{IH} | 10 max | 10 max | μA | |
| | | I_{IL} | -150 max | -150 max | μA | |
| Input Voltage | | V_{IH} | 2.2 min | 2.2 min | V | |
| | | V_{IL} | 0.8 max | 0.8 max | V | |
| Aging | | f/f | ±5 | ±5 | ppm/yr | |

TEST CIRCUIT

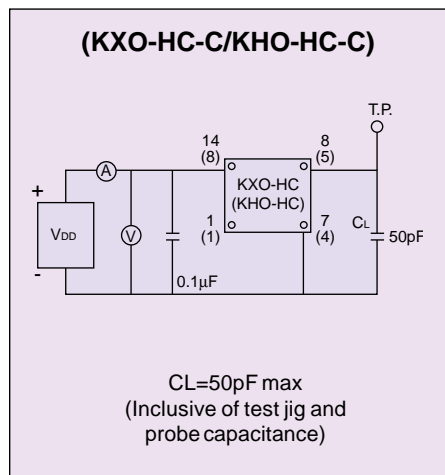

SHAPE OF OUTPUT WAVE

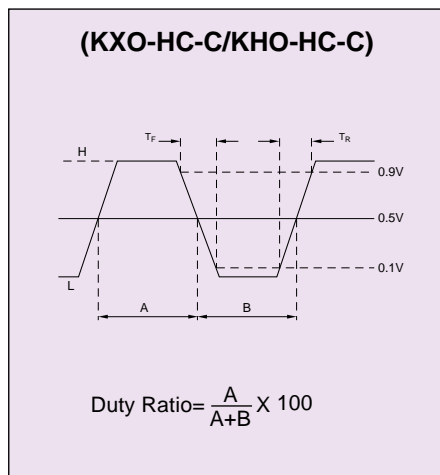

PIN CONNECTION

| KXO | KHO | |
|-----|-----|-----------------|
| 1 | 1 | N.C. or Control |
| 7 | 4 | Case /GND |
| 8 | 5 | Output |
| 14 | 8 | +5.0V D.C. |

ENABLE/DISABLE FUNCTION CHART

| Pin 1 | Pin 8 |
|--------------|----------------|
| High or Open | Oscillation |
| Low | High Impedance |

DIMENSIONS

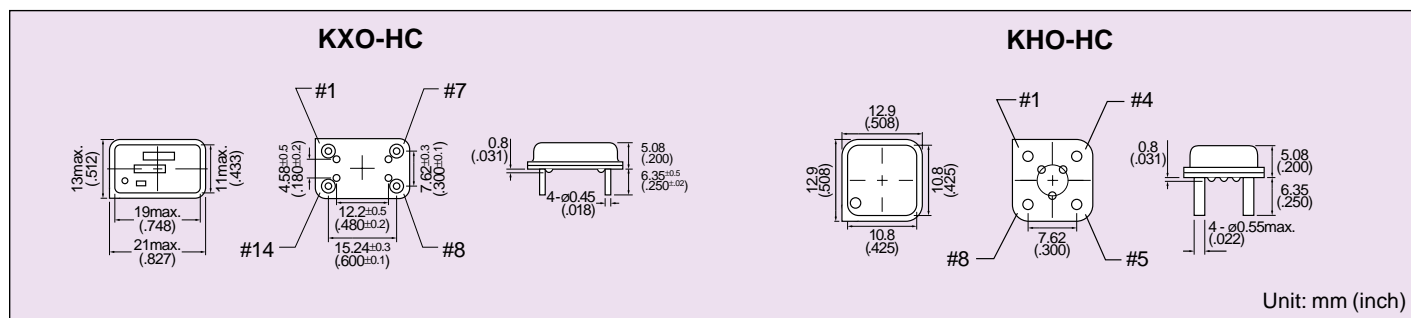

386 Series Clock Oscillators

HCMOS Drive - CMOS Compatible

f_o : 24, 32, 40, 50 MHz

FEATURES

- 1) Capable of driving the 80386 and surrounding LSI directly up to 150pF load
- 2) Replaces existing clock generator and/or buffer
- 3) 45/55 symmetry for all standard frequencies even at 150pF load
- 4) Enable/disable function as standard
- 5) 25 pieces per tube
- 6) Sold in increments of 100 pieces

HOW TO ORDER

386-HC 1 - C S E - 40.0000M T

- ① Type: 386 = 14 pin DIP
 ② Frequency precision: 1 = ± 100 ppm
 ③ Output level/Duty cycle
 CS = CMOS compatible/45 to 55%
 ④ Enable/disable function:
 □ = without function, E = with function
 ⑤ Frequency
 ⑥ Packaging: T = Tube



SPECIFICATIONS (386-HC)

| Parameters | | Code | Rating | Unit | Remarks |
|---|--------------------|---------------------------------|------------------------|--------------|------------------------------------|
| Output Frequency | | f_{OUT} | 24, 32, 40 50 | MHz MHz | CL=150pFmax CL=80pFmax |
| Frequency Precision (Inclusive of Temp. Voltage variation) | | $\Delta f/f$ | 1: ± 100 | ppm | Ta=0~70°C |
| Aging Rate | | $\Delta f/f$ | ± 5 | ppm/yr | |
| Operating Temperature | | T _{OPR} | 0~+70 | °C | |
| Storage Temperature Range | | T _{STR} | -55~+125 | °C | |
| Supply Voltage | | V _{DD} | 5 \pm 0.25 | V | |
| Supply Current | | I _{CC} | 65 max | mA | Cl=150pF, Ta=25°C |
| Output | Duty Ratio | Sy | 45~55 | % | 1/2 V _{DD} level |
| | "0" Level | V _{OL} | 0.1V _{DD} max | V | I _{OL} =12mA |
| | "1" Level | V _{OH} | 0.9V _{DD} min | V | I _{OL} =-1mA |
| | Rise and Fall Time | T _R , T _F | See Clock Time Table | nsec | |
| Enable/Disable Time | | | 100 max 100 max | nsec nsec | Type E Tristate Output |
| Input | Current | I _{IH} | 10 max | μ A | V _{DD} = 5.25V |
| | | I _{IL} | -150 max | μ A | V _{DD} =5.25V |
| | Voltage | V _{IH} | 2.2 min | V | |
| | | V _{IL} | 0.8 max | V | |
| Fan Out | | | 7 | TTL | |
| Load Capacitance | | C _L | 150 80 | pF pF | f=12.0MHz~40MHz f=40.1MHz~50MHz |

DIMENSIONS

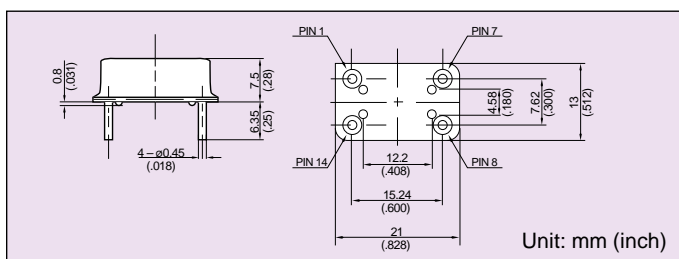

MARKINGS

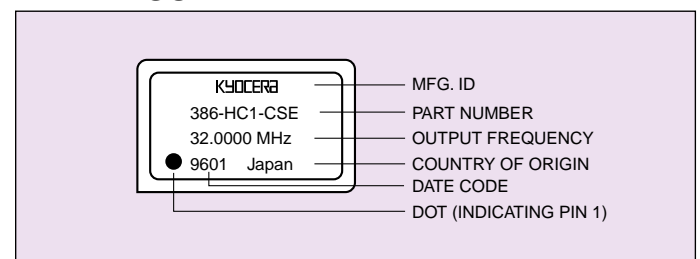

386 Series Clock Oscillators

HCMOS Drive - CMOS Compatible

f_o : 24, 32, 40, 50 MHz

TEST CIRCUIT

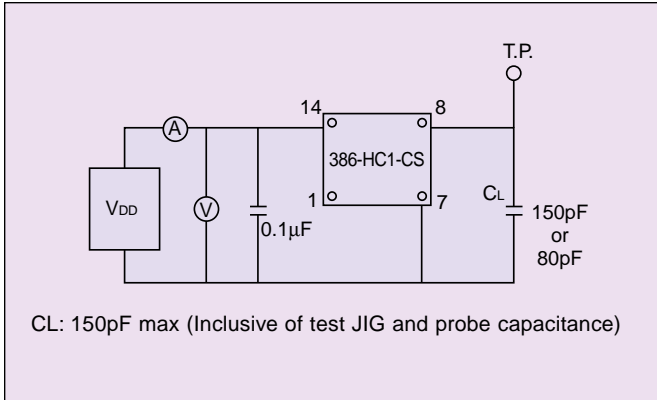

PIN CONNECTION

| 386 | Function |
|-----|-----------------|
| 1 | N.C. or Control |
| 7 | Case GND |
| 8 | Output |
| 14 | V _{DD} |

CLOCK TIME TABLE (32MHz, 40MHz)

| Frequency | 32MHz | | 40MHz | |
|---------------------------------|-------|-----|-------|-----|
| | Min | Max | Min | Max |
| Clock time (ns) | | | | |
| Clock high time t _{2a} | 9 | - | 8 | - |
| Clock high time t _{2b} | 5 | - | 5 | - |
| Clock low time t _{3a} | 9 | - | 8 | - |
| Clock low time t _{3b} | 7 | - | 6 | - |
| Clock tall time t ₄ | - | 7.5 | - | 8 |
| Clock tall time t ₅ | - | 7.5 | - | 8 |

CLOCK TIME TABLE (50MHz)

| Frequency | 50MHz | |
|---------------------------------|-------|-----|
| Clock time(ns) | Min | Max |
| Clock high time t _{2a} | 7 | - |
| Clock high time t _{2b} | 4 | - |
| Clock low time t _{3a} | 7 | - |
| Clock low time t _{3b} | 5 | - |
| Clock tall time t ₄ | - | 7 |
| Clock tall time t ₅ | - | 7 |

USA

AVX Myrtle Beach, SC Corporate Offices

Tel: 843-448-9411
FAX: 843-448-1943

AVX Northwest, WA

Tel: 360-699-8746
FAX: 360-699-8751

AVX North Central, IN

Tel: 317-848-7153
FAX: 317-844-9314

AVX Northeast, MA

Tel: 508-485-8114
FAX: 508-485-8471

AVX Mid-Pacific, CA

Tel: 408-436-5400
FAX: 408-437-1500

AVX Southwest, AZ

Tel: 602-834-7919
FAX: 602-834-8078

AVX South Central, TX

Tel: 972-669-1223
FAX: 972-669-2090

AVX Southeast, NC

Tel: 919-878-6357
FAX: 919-878-6462

AVX Canada

Tel: 905-564-8959
FAX: 905-564-9728

EUROPE

AVX Limited, England European Headquarters

Tel: ++44 (0)1252 770000
FAX: ++44 (0)1252 770001

AVX S.A., France

Tel: ++33 (1) 69.18.46.00
FAX: ++33 (1) 69.28.73.87

AVX GmbH, Germany - AVX

Tel: ++49 (0) 8131 9004-0
FAX: ++49 (0) 8131 9004-44

AVX GmbH, Germany - Elco

Tel: ++49 (0) 2741 2990
FAX: ++49 (0) 2741 299133

AVX srl, Italy

Tel: ++39 (0)2 665 00116
FAX: ++39 (0)2 614 2576

AVX sro, Czech Republic

Tel: ++420 (0)467 558340
FAX: ++420 (0)467 2844

ASIA-PACIFIC

AVX/Kyocera, Singapore Asia-Pacific Headquarters

Tel: (65) 258-2833
FAX: (65) 350-4880

AVX/Kyocera, Hong Kong

Tel: (852) 2-363-3303
FAX: (852) 2-765-8185

AVX/Kyocera, Korea

Tel: (82) 2-785-6504
FAX: (82) 2-784-5411

AVX/Kyocera, Taiwan

Tel: (886) 2-2516-7010
FAX: (886) 2-2506-9774

AVX/Kyocera, China

Tel: (86) 21-6249-0314-16
FAX: (86) 21-6249-0313

AVX, Malaysia

Tel: (60) 4-228-1190
FAX: (60) 4-228-1196

Elco, Japan

Tel: 045-943-2906
FAX: 045-943-2910

Kyocera, Japan

Tel: (81) 75-593-4518
FAX: (81) 75-502-2705

Contact:



<http://www.avxcorp.com>