

THIS DRAWING IS UNPUBLISHED. RELEASED FOR PUBLICATION .19
 © COPYRIGHT 19 BY AMP INCORPORATED. ALL RIGHTS RESERVED.

LOC	DIST	REVISIONS					
		P	LTR	DESCRIPTION	DATE	DWN	APVD
AJ	16	BH		REVISED PER EC 0S14-0288-02	18DEC02	DD	KW
		BH1		REVISED PER ECO-09-020935	09SEP09	KK	AEG

- 1 BRASS PER QQ-B-626.
- 2 BERYLLIUM COPPER PER ASTM-B-196
- 3 NYLON PER ASTM-D-4066, BLACK.
- 4 POLYMETHYLPENTENE GENERAL PURPOSE, NATURAL.
- 5 0.00076[.000030] MINIMUM GOLD PER MIL-G-45204.
- 6 0.00254[.000100] MINIMUM GOLD PER MIL-G-45204.
- 7 RG-180/U, RG-180A/U, RG-195/U, AND 21-597.
- 8 RG-58/U, RG-58A/U, RG-58B/U, AND RG-58C/U.
- 9 RG-55/U, RG-55A/U, RG-55B/U, RG-141/U, RG-142/U, AND RG-223/U.
- 10 BRAND REX T-209A.
- 11. SEE IS 1770.
- 12 NYLON PER ASTM-D-4066, NATURAL
- 13 DIELECTRIC MATERIAL: VALOX 325, WHITE
- 14 OBSOLETE PARTS: OBSOLETE CIS STREAMLINING PER D.RENAUD/D.SINISI

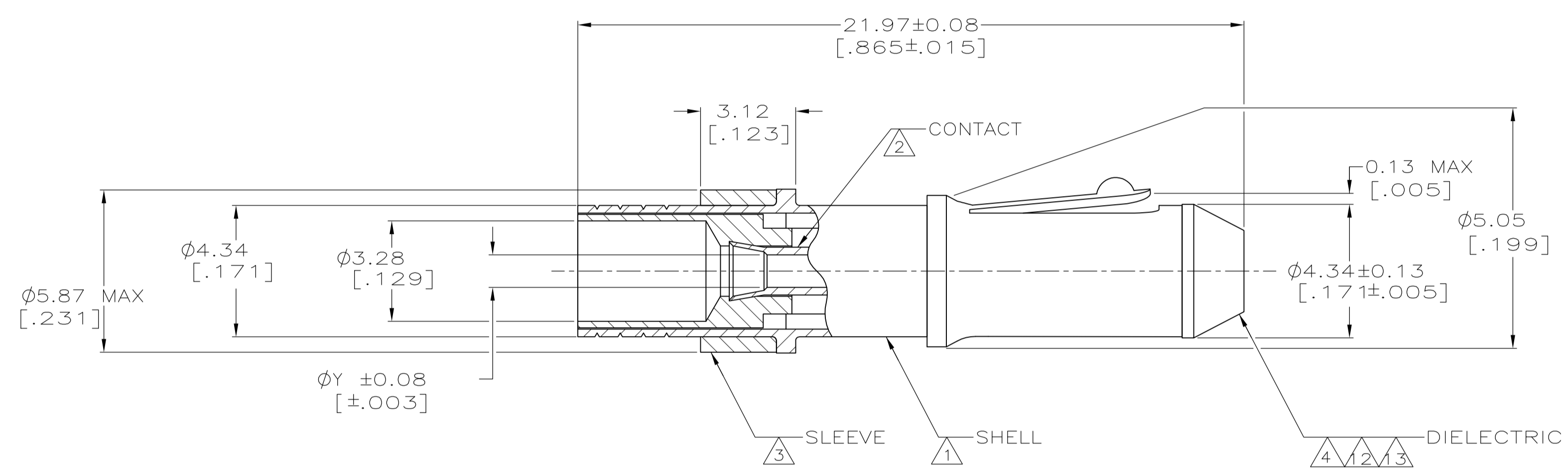

13	OBSOLETE	5	5	.030 OUNCES	-	-	1.07 [.042]	-	-	-	2-201145-7		
12	OBSOLETE	5	5	.030 OUNCES	-	-	1.07 [.042]	-	-	-	2-201145-6		
	OBSOLETE	6	6	.030 OUNCES	-	-	0.58 [.023]	-	-	-	1-201145-0		
	OBSOLETE	5	5	.030 OUNCES	-	-	0.81 [.032]	-	-	-	201145-8		
		5	5	.030 OUNCES	-	-	1.07 [.042]	-	-	-	201145-4		
		5	5	.030 OUNCES	-	-	0.58 [.023]	-	-	-	201145-2		
14	OBSOLETE	5	5	.030 OUNCES	-	-	1.07 [.042]	-	-	-	201145-1		
				CONTACT PLATING	SHELL PLATING	WEIGHT	CABLE SIZE	CRIMP TOOL	Y	3 FERRULE QTY=1	2 SPRING RETENTION QTY=1	1 PIN ASSY QTY=1	PART NUMBER

THIS DRAWING IS A CONTROLLED DOCUMENT.

DIMENSIONS: mm [INCHES]	TOLERANCES UNLESS OTHERWISE SPECIFIED: 0 PLC ±- 1 PLC ±- 2 PLC ±- 3 PLC ±0.20[.008] 4 PLC ±- ANGLES ±-	DWN J. LIPPERT 08 JAN 90	CHK M. SNEED 23 FEB 90	APVD B. ADAMS 23 FEB 90	NAME
MATERIAL SEE NOTES		FINISH SEE NOTES		PRODUCT SPEC 108-12021	
CUSTOMER DRAWING		SCALE 8:1		SHEET 1 OF 1	

AMP TYCO Electronics
Harrisburg, PA 17105-3608

PIN, MINIATURE SERIES

SIZE CAGE CODE DRAWING NO
A100779 C-201145

RESTRICTED TO
REV BHI