

PQ1CZ41H2ZxH

TO-220 Type Chopper Regulator,
built-in 300kHz oscillation circuit

■ Features

1. Maximum switching current: 1.5A
2. Built-in ON-OFF control function
3. Built-in soft start function to suppress overshoot of output voltage in power on sequence or ON/OFF control sequence
4. Built-in oscillation circuit
(Oscillation frequency: TYP.300kHz)
5. Built-in overheat protection function, overcurrent protection function
6. SC-63 Surface Mount Type package
7. Variable output voltage
(Output variable range: V_{ref} to 35V/− V_{ref} to −30V)
[Possible to select step-down output/inverting output according to external connection circuit]
8. **PQ1CZ41H2ZZH**: Sleeve-packaged product
PQ1CZ41H2ZPH: Tape-packaged product
9. RoHS directive compliant

■ Applications

1. Color TV, STB
2. LCD monitors
3. Facsimiles, plinters and other OA equipment
4. CD-ROM drives/DVD-ROM drivers
5. Air conditioners

■ Absolute Maximum Ratings

($T_a=25^{\circ}\text{C}$)

Parameter	Symbol	Rating	Unit
*1 Input voltage	V_{IN}	40	V
Error input voltage	V_{ADJ}	7	V
Input - output voltage	V_{I-O}	41	V
*2 Output - COM voltage	V_{OUT}	-1	V
*3 ON/OFF control voltage	V_C	-0.3 to +40	V
Switching current	I_{SW}	1.5	A
*4 Power dissipation	P_D	8	W
*5 Junction temperature	T_j	150	$^{\circ}\text{C}$
Operating temperature	T_{opr}	-40 to +85	$^{\circ}\text{C}$
Storage temperature	T_{stg}	-40 to +150	$^{\circ}\text{C}$
Soldering temperature	T_{sol}	260(10s)	$^{\circ}\text{C}$

- *1 Voltage between V_{IN} terminal and COM terminal
 *2 Voltage between V_{OUT} terminal and COM terminal
 *3 Voltage between ON/OFF control and COM terminal
 *4 P_D : With infinite heat sink
 *5 There is case that over heat protection function operates at the temperature $T_j=125^{\circ}\text{C}$ to 150°C , so this item cannot be used in this temperature range.

■ Outline Dimensions

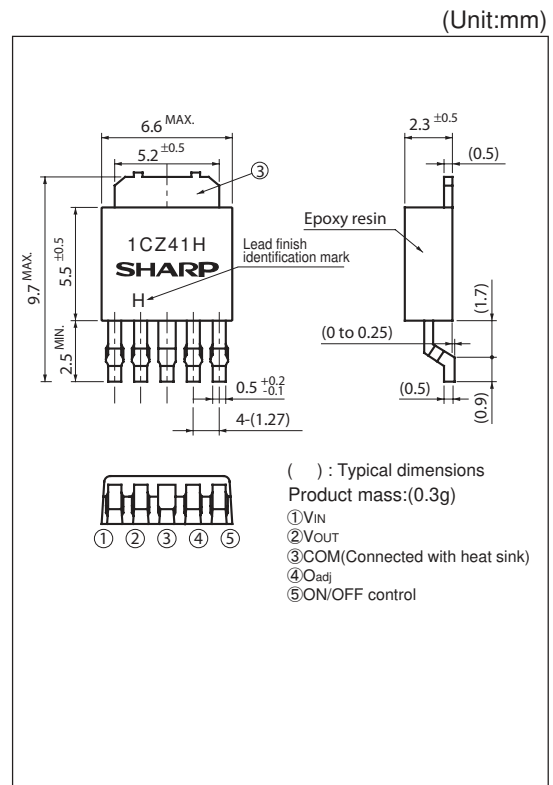

Lead finish:Lead-free solder plating
(Composition: Sn2Cu)

Notice The content of data sheet is subject to change without prior notice.

In the absence of confirmation by device specification sheets, SHARP takes no responsibility for any defects that may occur in equipment using any SHARP devices shown in catalogs, data books, etc. Contact SHARP in order to obtain the latest device specification sheets before using any SHARP device.

Electrical Characteristics

(Unless otherwise specified, condition shall be $V_{IN}=12V, I_o=0.2A, V_o=5V$, ON-OFF terminals is open, $T_a=25^\circ C$)

Parameter	Symbol	Conditions	MIN.	TYP.	MAX.	Unit
Output saturation voltage	V_{SAT}	$I_{SW}=1A$	—	0.9	1.5	V
Reference voltage	V_{ref}	—	1.235	1.26	1.285	V
Reference voltage temperature fluctuation	ΔV_{ref}	$T_j=0$ to $125^\circ C$	—	± 0.5	—	%
Load regulation	$ RegL $	$I_o=0.2$ to $1A$	—	0.2	1.5	%
Line regulation	$ RegI $	$V_{IN}=8$ to $35V$	—	1.2	2.5	%
Efficiency	η	$I_o=1A$	—	84	—	%
Oscillation frequency	f_o	—	270	300	330	kHz
Oscillation frequency temperature fluctuation	Δf_o	$T_j=0$ to $125^\circ C$	—	± 3	—	%
Overcurrent detecting level	I_L	Switching current peak	1.55	2.0	2.6	A
Charge current	I_{CHG}	②,④ terminals is open,⑤ terminal	—	-10	—	μA
Input threshold voltage	V_{THL}	Duty ratio=0%,④ terminal=0V,⑤ terminal	—	1.3	—	V
	V_{THH}	Duty ratio=100%,④ terminal=1.1V, ⑤ terminal	—	2.3	—	V
ON threshold voltage	$V_{TH(ON)}$	④ terminal=0V,⑤ terminal	0.7	0.8	0.9	V
Stand-by current	I_{SD}	$V_{IN}=40V,⑤$ terminal=0V	—	140	400	μA
Output OFF-state dissipation current	I_{QS}	$V_{IN}=40V,④$ terminal=0V,⑤ terminal =0.9V	—	8	12	mA

Fig.1 Test Circuit

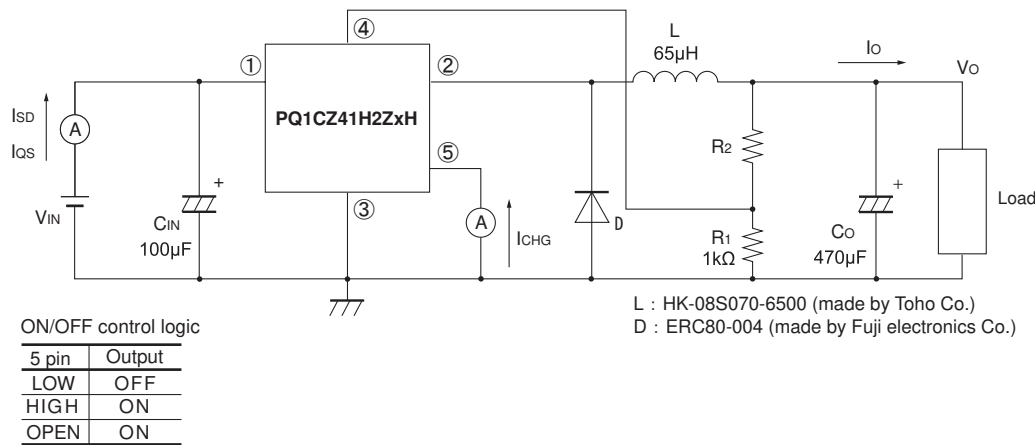
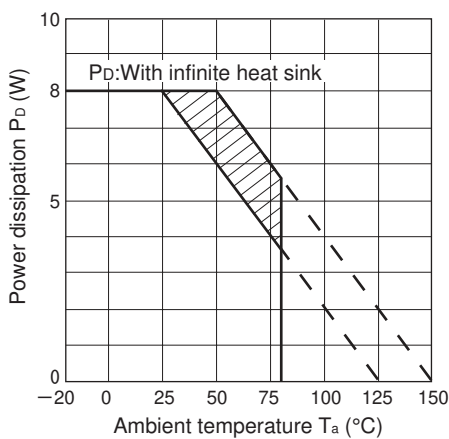

Fig.2 Power Dissipation vs. Ambient Temperature



Note) Oblique line portion: Overheat protection may operate in this area

Fig.3 Overcurrent Protection Characteristics (Typical Value)

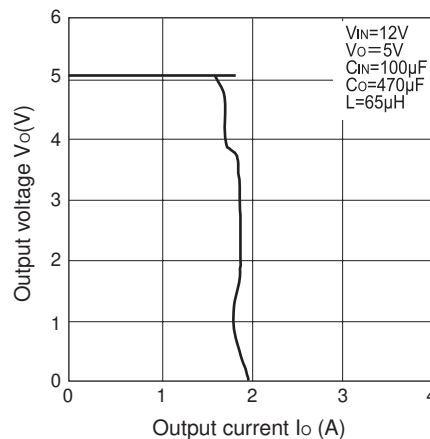

Fig.4 Efficiency vs. Input Voltage

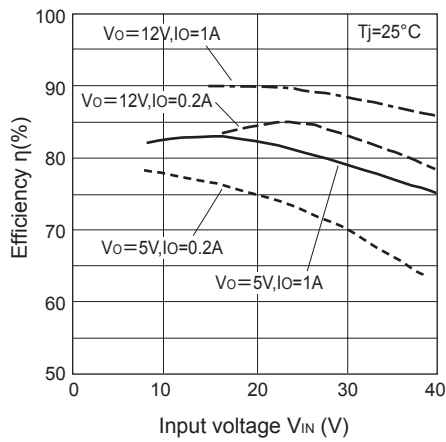

Fig.5 Output Saturation Voltage vs. Switching Current

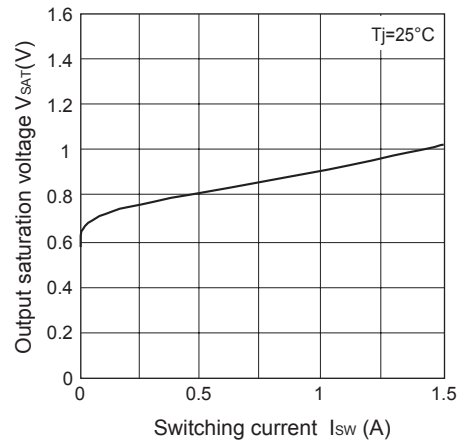

Fig.6 Stand-by Current vs. Input Voltage

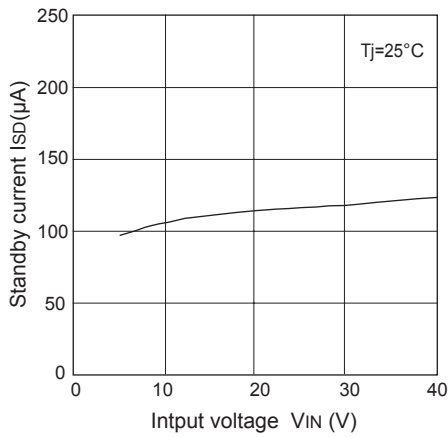

Fig.7 Reference Voltage Fluctuation vs. Junction Temperature

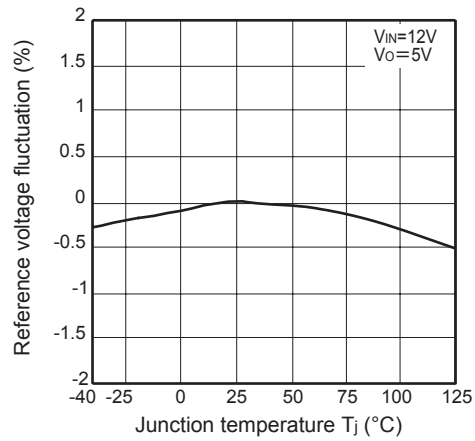

Fig.8 Load Regulation vs. Output Current

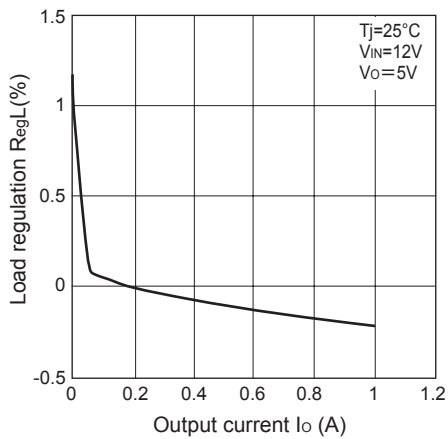

Fig.9 Line Regulation vs. Input Voltage

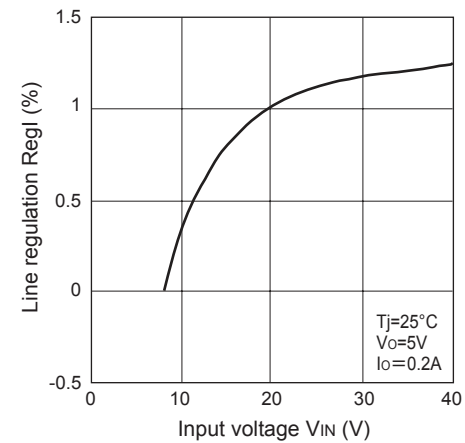

Fig.10 Oscillation Frequency Fluctuation vs. Junction Temperature

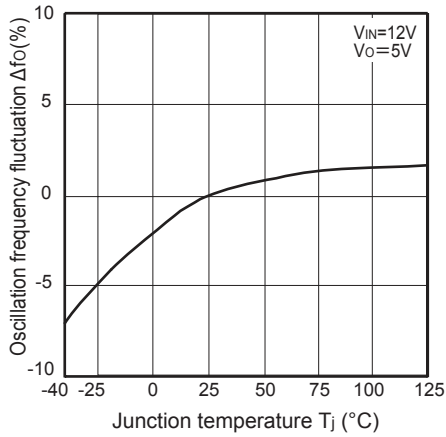

Fig.11 Overcurrent Detecting Level Fluctuation vs. Junction Temperature

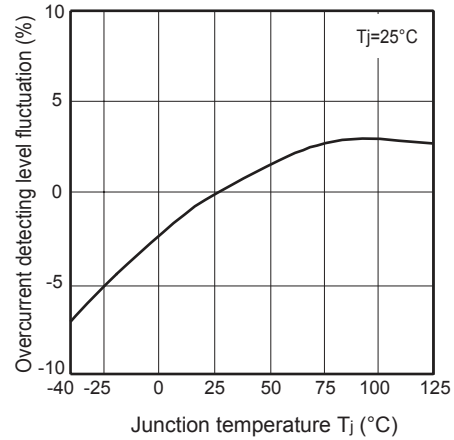

Fig.12 On Threshold Voltage vs. Junction Temperature

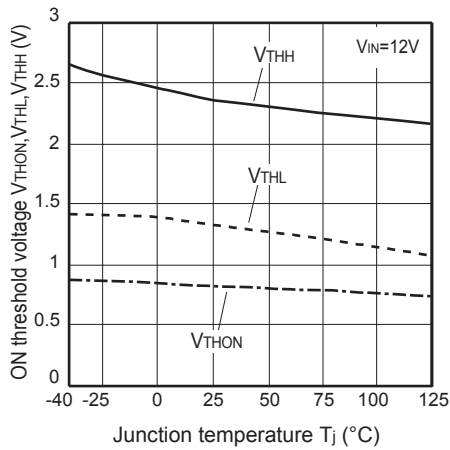

Fig.13 Operating Dissipation Current vs. Input Voltage

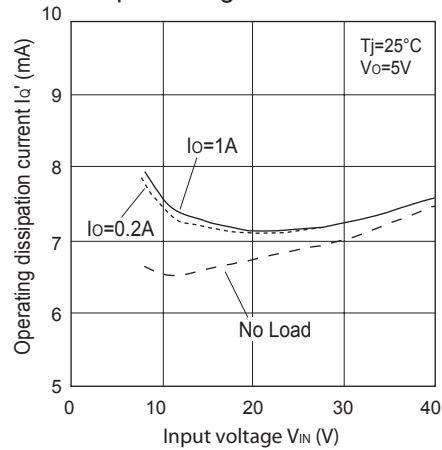
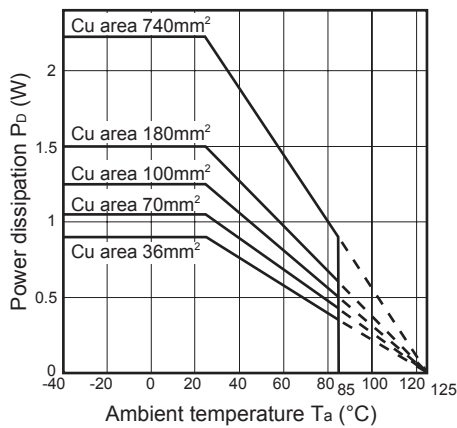
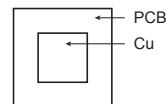

Fig.14 Power Dissipation vs. Ambient Temperature (Typical Value)



Mounting PCB



Material : Glass-cloth epoxy resin
 Size : 50×50×1.6mm
 Cu thickness : 35 μ m

Fig.15 Block Diagram

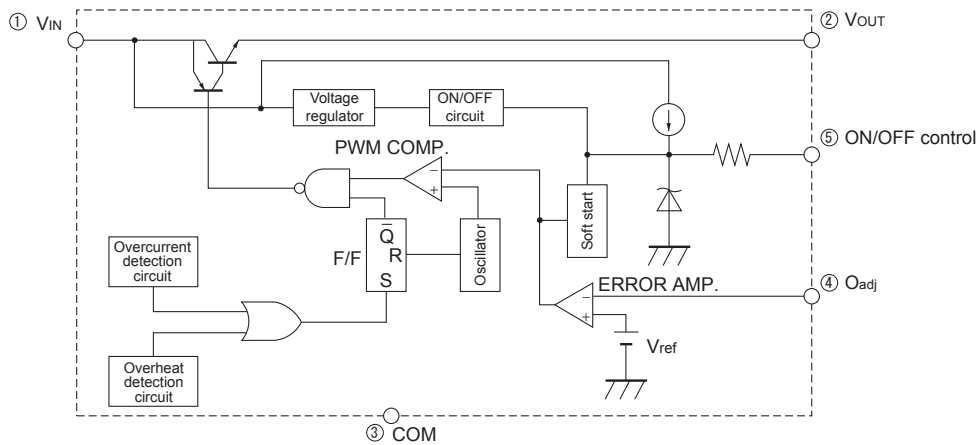

Fig.16 Step Down Type Circuit Diagram

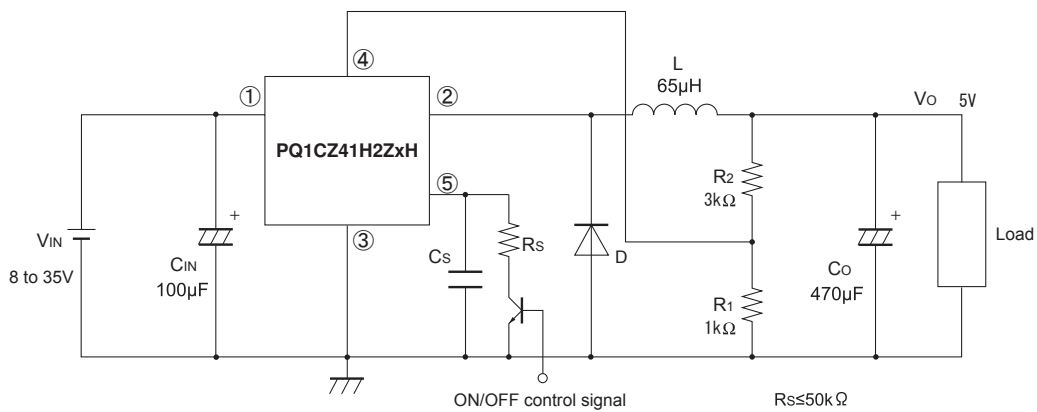
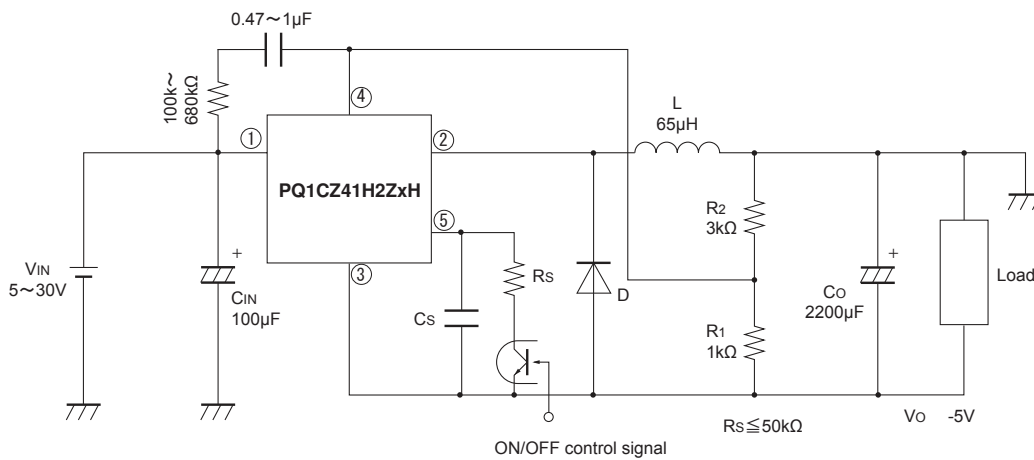

Fig.17 Polarity Inversion Type Circuit Diagram



In case that polarity is reverse, depending on the conditions, there is cases that output voltage can not gain, please use this device after confirming the output voltage at the actual conditions.