

REVISIONS			
REV	DESCRIPTION	DATE	APPROVED
01 ₂	REVISED	K.LE 2/20/97	<i>[Signature]</i>

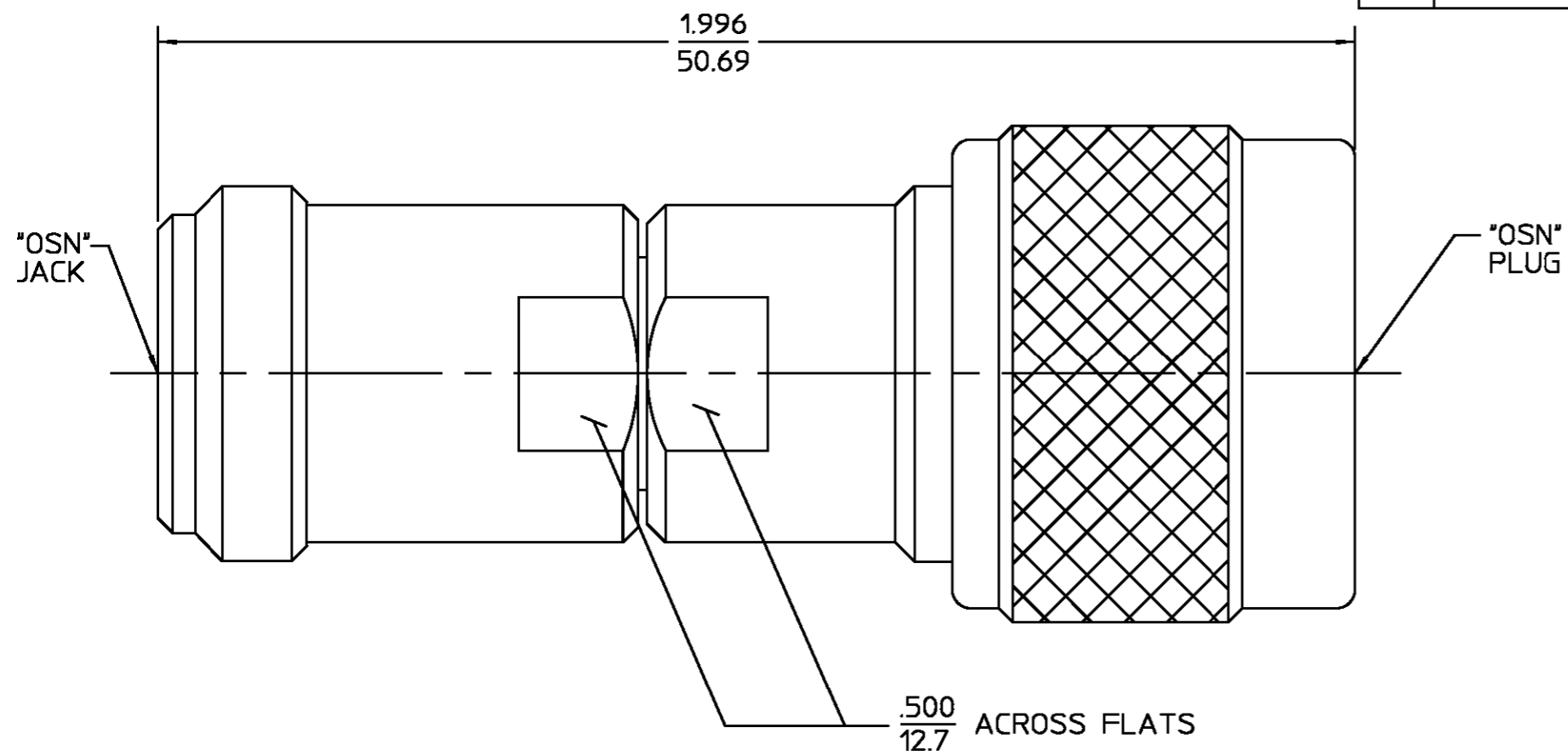

Frequency Range(GHz) DC TO 18.0
 VSWR: 1.10 + .01f(GHz)
 Insultation Resistance: 5,000
 Dielectric With Voltage(VRMS MIN): 1,500
 Contact Resistance: 4.1 Millohms Max
 Insertion Loss: $.07\sqrt{f(\text{GHz})}$
 Operating Temperature Range: -65 to +125°C

COMPONENT	MATERIAL	FINISH
HOUSING COUPLING NUT	STAINLESS STEEL PER ASTM-A484 AND ASTM-A582, TYPE 303	PASSIVATE PER QQ-P-35
DIELECTRIC	TFE FLUOROCARBON PER ASTM-D-1457	N/A
CENTER CONTACT	BERYLLIUM COPPER PER ASTM-B-196 OR ASTM-B-197, ALLOY C17300, CONDITION H	GOLD PLATE PER MIL-G-45204
CONTACT EXT. BUSHING	BRASS PER ASTM-B-16, HALF HARD	GOLD PLATE PER MIL-G-45204
RETAINING RING	PHOSPHOR BRONZE PER QQ-B-750, GRADE B2	N/A
GASKET	SILICONE RUBBER PER ZZ-R-765	N/A

UNLESS OTHERWISE SPECIFIED DIMENSIONS ARE IN INCHES		
FRAC.	DEC.	ANGLES
± 1/64	±.005	± 1°

These drawings and specifications are the property of M/A COM Interconnect Div. and shall not be reproduced or copied or used in whole or in part as the basis for the manufacture or sale of item(s) without written permission.

DRAWN BY	EJC	DATE	9-10-69
CHECKED BY	BWC	DATE	9-15-69
APPD BY	DN	DATE	9-15-69

AMP
 AMP Incorporated
 140 Fourth Avenue
 Waltham, MA 02451-7599

USE ASSY PROCEDURE
 NO. A.P. N/A

TITLE "OSN" JACK TO "OSN" PLUG ADAPTER			
SIZE	CODE IDENT NO.	REV	
B	26805	3082-0000-00	01 ₂
SCALE	4:1		SHEET 1 OF 1

CUSTOMER DRAWING

AMP PART # 1057374-1
 SHEET 1 OF 1 REV A