

DSCT36

Potentiometer Input Transmitters



Description

Each DSCT36 potentiometer input transmitter provides a single channel of potentiometer input which is filtered, isolated, amplified, and converted to a process current output (Figure 1). Signal filtering is accomplished with a five-pole filter, which provides 85dB of normal-mode rejection at 60Hz and 80dB at 50Hz. An anti-aliasing pole is located on the field side of the isolation barrier, and the other four are on the process loop side. After the initial field-side filtering, the input signal is chopped by a proprietary chopper circuit. Isolation is provided by transformer coupling, again using a proprietary technique to suppress transmission of common mode spikes or surges.

Potentiometer excitation is provided from the transmitter using a precision current source. The excitation current is small (less than 0.26mA) which minimizes self-heating of the potentiometer. Lead compensation is achieved by matching two current paths which cancels the effects of lead resistance.

Special input and output circuits on the DSCT36 transmitters provide protection against accidental connection of power-line voltages up to 240VAC and against transient events as defined by ANSI/IEEE C37.90.1. Signal and loop power lines are secured to the module using screw terminals, which are in pluggable terminal blocks for ease of system assembly and reconfiguration.

The modules have excellent stability over time and do not require recalibration, however, zero and span settings are adjustable up to ±10% to accommodate situations where fine-tuning is desired. The adjustments are made using potentiometers located under the front panel label and are non-interactive for ease of use.

Features

- Interfaces to Potentiometers up to 10kΩ
- Process Current Output
- 1500Vrms Transformer Isolation
- ANSI/IEEE C37.90.1 Transient Protection
- Input and Output Protected to 240VAC Continuous
- Up to 60V Loop Voltage
- 160dB CMR
- 85dB NMR at 60Hz, 80dB at 50Hz
- ±0.03% Accuracy
- ±0.01% Linearity
- Easily Mounts on Standard DIN Rail
- CSA C/US Certified
- CE Compliant

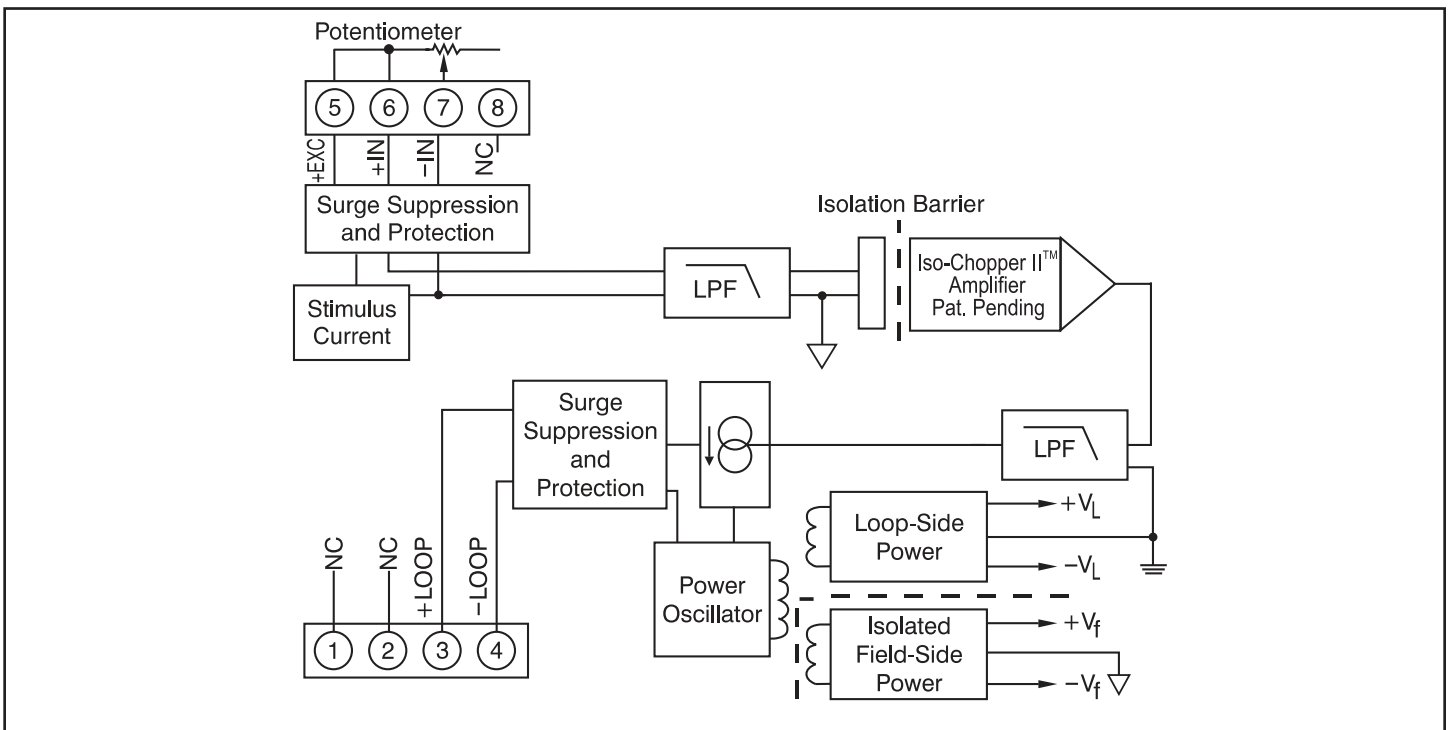

Figure 1: DSCT36 Block Diagram

Specifications Typical* at $T_A = +25^\circ\text{C}$ and +24VDC loop voltage

Module	DSCT36
Input Range	0Ω to 10kΩ
Input Resistance	
Normal	50MΩ
Power Off	66kΩ
Overload	66kΩ
Input Protection	
Continuous	240Vrms max
Transient	ANSI/IEEE C37.90.1
CMV, Input to Output	
Continuous	1500Vrms max
Transient	ANSI/IEEE C37.90.1
CMR (50Hz or 60Hz)	160dB
NMR	85dB at 60Hz, 80dB at 50Hz
Adjustability	±10% Zero and Span
Accuracy ⁽¹⁾	±0.03%
Conformity	±0.01%
Stability	
Offset	±50ppm/°C
Gain	±100ppm/°C
Sensor Excitation Current	0.26mA; 100Ω, 500Ω Sensor 0.13mA; 1kΩ Sensor 0.065mA; 10kΩ Sensor
Lead Resistance Effect	±0.01Ω/Ω; 100Ω, 500Ω, 1kΩ Sensor ±0.02Ω/Ω; 10kΩ Sensor
Noise	
Output, 100kHz	3μArms
Bandwidth, -3dB	3Hz
Response Time, 90% Span	165ms
Output Range	4mA to 20mA
Output Limits	
Under-range	3mA
Over-range	29mA
Output Protection	
Reverse Polarity	Continuous
Over-voltage	240Vrms Continuous
Transient	ANSI/IEEE C37.90.1
Loop Supply Voltage	10.8V to 60V
Loop Supply Sensitivity	±0.0005% V
Turn-On Delay	400ms
Mechanical Dimensions (h)(w)(d)	2.95" x 0.89" x 4.13" (75mm x 22.5mm x 105mm)
Mounting	DIN EN 50022 -35x7.5 or -35x15 rail
Environmental	
Operating Temperature	-40°C to +80°C
Storage Temperature	-40°C to +80°C
Relative Humidity	0 to 95% Noncondensing
Emissions, EN61000-6-4	ISM, Group 1
Radiated, Conducted	Class A
Immunity EN61000-6-2	ISM, Group 1
RF	Performance A ±0.5% Span Error
ESD, EFT	Performance B

NOTES:

*Contact factory or your local Dataforth sales office for maximum values.

(1) Includes linearity, hysteresis and repeatability.

Ordering Information

Model	Input Range
DSCT36-01	0 to 100Ω
DSCT36-02	0 to 500Ω
DSCT36-03	0 to 1kΩ
DSCT36-04	0 to 10kΩ