



## **High-Speed SERDES Briefcase Board**

**Evaluation Board for ORSO/ORT82G5, ispGDx2™ and ispPAC® Devices**

---

### **User's Guide**

---

## Introduction

This user's guide describes the Lattice High-Speed SERDES Briccase Board, a stand-alone evaluation board for the Lattice ORSO82G5 and ORT82G5 Field Programmable System Chips (FPSCs). The board also contains a socket and test connections for evaluation of the ispGDx2-256 programmable digital crosspoint switch, and an integrated power supply controller by the ispPAC-POWRT1208. The board includes the following features:

- Stand-alone power source
- ispVM® programming support
- On-board reference clock sources (external clock source can be used)
- Discrete high speed interface SMA test points and clock connections
- Simulated matched backplane controlled impedance test runs

The contents of this user's guide include top level functional descriptions of the various portions of the evaluation board, descriptions of all connectors, diodes and switches and a complete set of schematics for version 1.1 of the board. Figure 1 shows the functional partitioning of the board.

**Figure 1. Lattice High-Speed SERDS Briccase Board**

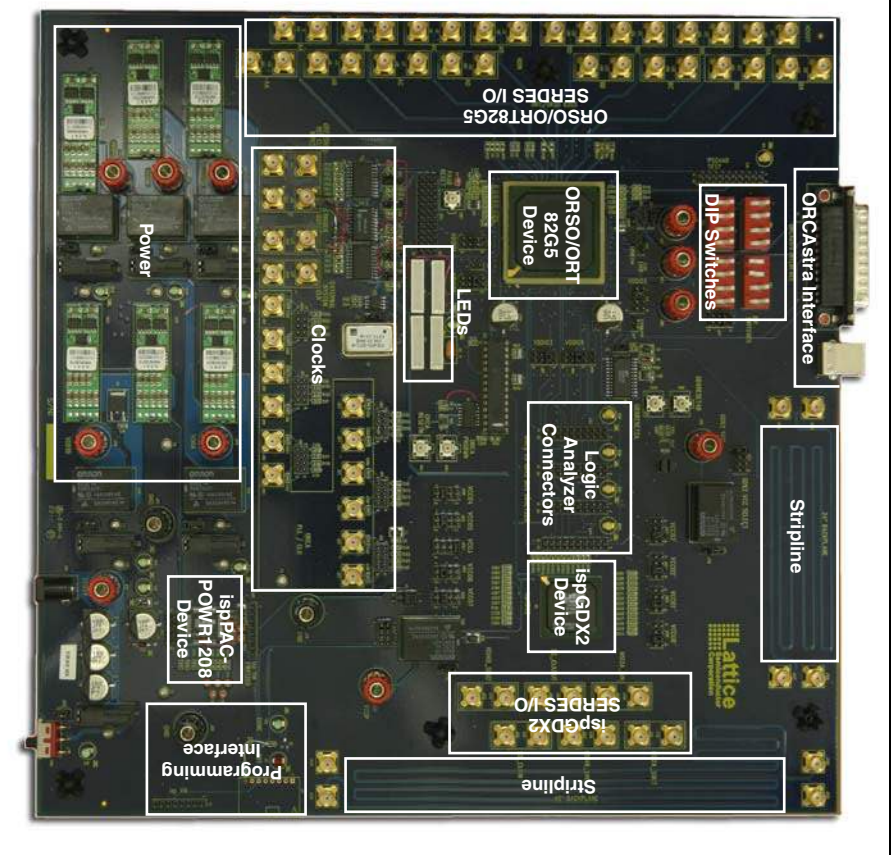

The evaluation board is also supported by the ORCAstra™ graphical user interface (GUI). ORCAstra enables the user to configure bits on the control registers of the FPSC devices via a PC. For more information, refer to the *ORCAstra Users Manual* available on the Lattice web site at [www.latticesemi.com](http://www.latticesemi.com). The Lattice web site also contains further information about the Lattice devices used on this board, including device data sheets and application notes.

---

## Electrical, Mechanical and Environmental Specifications

The nominal board dimensions are 12 inches by 12 inches. The environmental specifications are as follows:

- Operating temperature: 0 °C to 55 °C
- Storage temperature: -40 °C to 75 °C
- Humidity: < 95% without condensation

Regulated power is available from on-board supplies operated from a wall-type 5V supply. Alternately, power may be supplied from an external source: 3.3V, 2.5V, 1.8V and 1.5V power buses are supplied.

The devices may be driven by the on-board 156MHz oscillator or, to allow operation at different speeds, from independent differential clock sources. When the clock is sourced from the internal oscillator, a trigger output for test equipment is available.

In addition to the high-speed SMA connectors, five logic analyzer connections are supplied for Agilent P/N 01650-63203 isolation adapters or equivalents. Standard headers and DIP switches are provided for setup of the evaluation environment, and LEDs are provided to indicate current board and device status. Connections are provided both to device pins with dedicated functions, and to general purpose I/Os from the FPGA portion of the FPSC.

## Jacks, Connectors, Diodes and Switches

### Bitstream Configuration Connectors

The following connectors are used for configuration and programming.

**Table 1. Programming Connections**

Jack Number	Size	Function
J1	8 pins (6 used)	ispVM Download - FPSCs and ispGDX2
J4	8 pins (6 used)	ORCA® Download (not populated)
J60	8 pins (6 used)	ispVM Download - ispPAC-POWR1208

Notes:

1. LEDs are used to indicate the status of FPSC and ispGDX2 downloads.
2. The preference selections shown in Figure 2 are recommended for generating ORCA bitstreams. Note particularly the selections of the "Cycle 2" and "Cycle 4" options.
3. Programming jacks J1 and J60 are intended for use with the Lattice ispDOWNLOAD® Cable, type pDS4102-DL2.

Figure 2. ispVM Preference Settings for ORCA Bitstreams

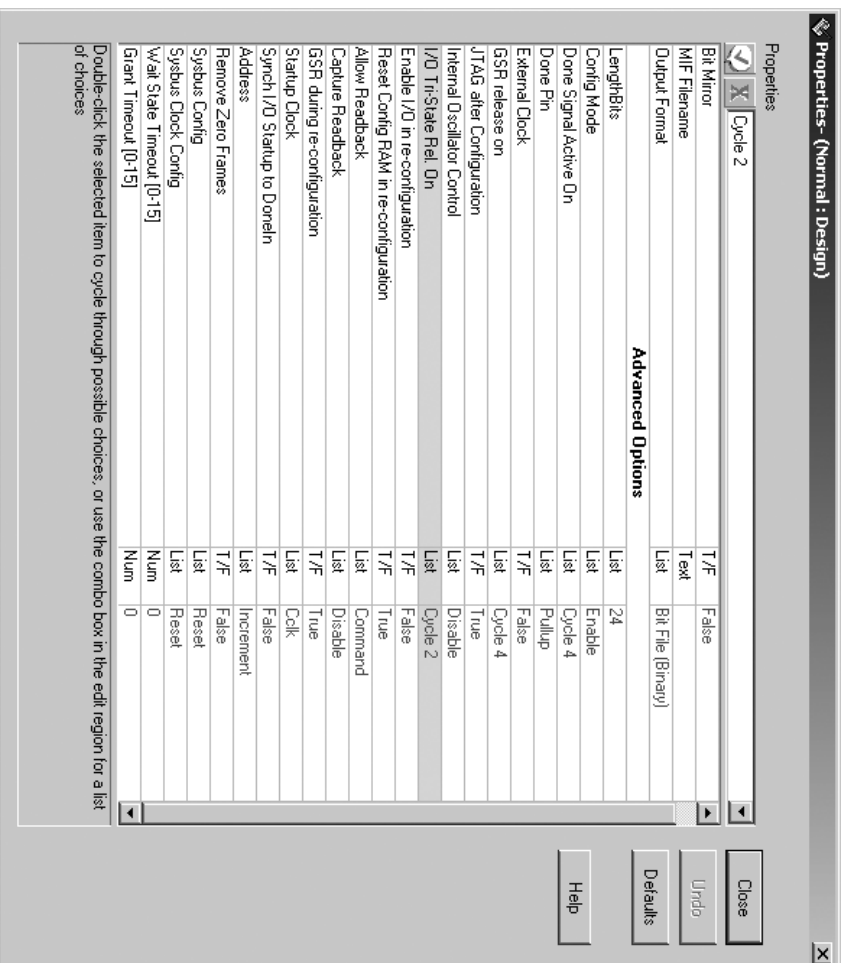

Note: With some operating system configurations, the ispVM software will generate failure and error messages related to the USB when programming is first attempted. If this occurs, do the following:

1. Click on **Options** in the ispVM toolbar and select **Cable and I/O Port Setup**
2. Verify that “Cable Type” is “USB” and “Port Setting” is “Ezusb-0”
3. Unplug the USB cable from the system running ispVM
4. Replug the USB cable into the system running ispVM
5. Click **OK**

The device should now program successfully.

## ORCAstra Interface Connectors

The following connectors are used to interface with the ORCAstra GUI.

Table 2. ORCAstra GUI Connections

Jack Number	Size	Function
P1	24 pin	Parallel Port (LPT) ORCAstra Interface
J53	4 pin	Universal Serial Bus (USB) ORCAstra Interface

Note: The USB serial interface device and supporting EPPROM are not specifically highlighted on the board photograph in Figure 1.

## Headers

Standard 0.100 headers are provided for interconnecting points on the board. This can be accomplished with 0.100 IDC connectors and ribbon cable for bus connections or 0.025 pin socket patch cords (such as Pomona Electronics #5948. See [www.pomonaelectronics.com](http://www.pomonaelectronics.com) for more information).

The following standard headers are used on the evaluation board. Boards are provided with default connections (ORSO/ORT82G5 listed here. Refer to the schematics in Appendix A for other configuration options).

**Table 3. General Purpose Headers**

Jack Number	Related Schematic	Size	Function	Default Connection
J2	Figure 6	1x2	Tristates ORSO/ORT82G5 (located between J55 and J56)	None
J3	Figure 6	3x2	Sets up configuration path, U1, U2 or daisy chain (located under J128)	[1-2][3-4][5-6]
J37	Figure 8	1x2	ORSO/ORT82G5 PTEMP pin (located to the right of J69)	None
J39	Figure 9	2->1	On-Board Oscillator Power, +3.3 or GND (located below the LEDs and J54)	[1-2]
J41	Figure 9	2->1	External/On-board Clock Select (located below the LEDs and J54)	[1-2] <sup>1</sup>
J42	Figure 9	2->1	On-Board Clock __2 (located below the LEDs and J54)	[2-3] <sup>1</sup>
J45	Figure 10	2->1	ORSO/ORT82G5 REF_CLKA Select for Quad A (located below the LEDs and J54)	[1-2]
J50	Figure 10	2->1	ORSO/ORT82G5 REF_CLKB Select, for Quad B (located below the LEDs and J54)	[2-3]
J51	Figure 11	4x2	VDD select for DIP Switches	[1-2]
J52	Figure 12	1x2	Enables ORCAstra Parallel Port Interface (located above J68)	None
J141	Figure 12	3x12	Configures ORCAstra Parallel Port or USB Interface	[2,3][5-6][8-9] [11-12][14-15] [17-18][20-21][23-24]
J61	Figure 14	1x2	ispPAC Input (jumper shorts to ground)	None
J62	Figure 14	1x2	ispPAC Input (jumper shorts to ground)	None
J63	Figure 14	1x2	ispPAC Input (jumper shorts to ground)	None
J64	Figure 14	1x2	ispPAC Input (jumper shorts to ground)	None
J140	Figure 14	1x2	5V connection to evaluation board – remove jumper to configure ispPAC (located to the right of J58 and left of SW8)	[1-2]
J65	Figure 15	4x2	VDDIO0 Select, ORSO/ORT82G5 I/O	[1-8]
J66	Figure 15	4x2	VDDIO1 Select, ORSO/ORT82G5 I/O	[1-8]
J67	Figure 15	4x2	VDDIO2 Select, ORSO/ORT82G5 I/O	[1-5]
J68	Figure 15	4x2	VDDIO6 Select, ORSO/ORT82G5 I/O	[1-5]
J69	Figure 15	4x2	VDDIO5 Select, ORSO/ORT82G5 I/O	[1-5]
J70	Figure 16	2->1	External/Internal Power Select, 3.3V	[1-2]
J71	Figure 16	2->1	External/Internal Power Select, analog 1.5V	[1-2]
J74	Figure 16	2->1	External/Internal Power Select, 2.5V	[1-2]
J76	Figure 16	2->1	External/Internal Power Select, 1.5V	[1-2]
J77	Figure 16	2->1	External/Internal Power Select, 1.8V	[1-2]
J81	Figure 17	4x2	Input Configure, ORCA Primary Clock 0 Test	[1-2][7-8]
J84	Figure 17	4x2	Input Configure, ORCA Primary Clock 1 Test	[1-2][7-8]
J86	Figure 17	4x2	Input Configure, ORCA PLL Clock 0 Test	[1-2][7-8]
J90	Figure 17	4x2	Input Configure, ORCA PLL Clock 1 Test	[1-2][7-8]
J92	Figure 17	4x2	Input Configure, ORCA PLL Clock 6 Test	[1-2][7-8]

**Table 3. General Purpose Headers (Continued)**

Jack Number	Related Schematic	Size	Function	Default Connection
J96	Figure 17	4x2	Input Configure, ORCA PLL Clock 7 Test	[1-2] [7-8]
J98	Figure 18	2>1	External/Internal Power Select, VDD_OB (located left of J69)	[1-2]
J100	Figure 18	2>1	External/Internal Power Select, VDD_JB (located left of J69)	[1-2]
J102	Figure 18	2>1	External/Internal Power Select, VDDA (located left of J69)	[1-2]
JP1	Figure 20	2x2	Pushbutton/FPGA GDXRESET Select	None
J116	Figure 21	1x2	ispGDXX2 Manual Tristate (Jumper tristates ispGDXX2), located above J124	None
J117	Figure 22	4x2	VCC Select, ispGDXX2	[2-4]
J118	Figure 22	2>1	External/Internal Power Select, ispGDXX2 VCC	[1-2]
J120	Figure 23	4x2	VCCO0 Select, ispGDXX2	[1-5]
J121	Figure 23	4x2	VCCO5 Select, ispGDXX2	[1-5]
J122	Figure 23	4x2	VCCO6 Select, ispGDXX2	[1-5]
J123	Figure 23	4x2	VCCO1 Select, ispGDXX2	[1-5]
J124	Figure 23	4x2	VCCO2 Select, ispGDXX2	[1-5]
J125	Figure 23	4x2	VCCO3 Select, ispGDXX2	[1-5]
J126	Figure 23	4x2	VCCO4 Select, ispGDXX2	[1-5]
J127	Figure 23	4x2	VCCJ Select (JTAG voltage)	[1-5]
J128	Figure 23	4x2	VCCO7 Select, ispGDXX2	[1-5]
J129	Figure 23	2>1	External/Internal Power Select, ispGDXX2 VCCP (located above J131)	[1-2] <sup>2</sup>
J130	Figure 23	4x2	VCCA Select, ispGDXX2 (located to the left of J131)	[2-6] <sup>2</sup>

1. Errata for Jacks J41 and J42 is as follows: To select an external clock source via SMA connections, remove default jumpers on J41 and J42 and add a connection between J42[1] to J41[2]. This can be accomplished using a 0.25 pin socket 6" patch cord(Pomona P/N 5948 or similar<sup>1</sup>).
2. Lattice recommends VCCP0 and VCCP1 be connected to the appropriate voltage supply, even when the PLL and sysHSI circuits will not be used.

### J54 and TP1

This evaluation board has wiring for a 12x3 header (J54) to support SERDES testing, and a test point (TP1) for observing the ATMOUT\_A signal (see Figure 13). Both are located next to the PASB RESET pushbutton. In general, this header location is not populated.

### TP2 through TP9

The evaluation board has wiring for 8 test points (TP2 through TP9) for observing the operation of the ispPAC PWR1208 Power Sequencer (see Figure 14).

**SMA Connectors**

The following SMA connectors are used on the evaluation board (see Figure 1).

**Table 4. ORSO/OFT82G5 Quad A Serial I/O (see Figure 7)**

Jack Number	I/O Name
J14	HDIN_AA
J13	HDIP_AA
J16	HDIN_AB
J15	HDIP_AB
J18	HDIN_AC
J17	HDIP_AC
J20	HDIN_AD
J19	HDIP_AD
J10	HDOUTN_AA
J7	HDOUTP_AA
J6	HDOUTN_AB
J5	HDOUTP_AB
J9	HDOUTN_AC
J8	HDOUTP_AC
J12	HDOUTN_AD
J11	HDOUTP_AC

**Table 5. ORSO/OFT82G5 Quad B Serial I/O (see Figure 8)**

Jack Number	I/O Name
HDIN_BA	J22
HDIP_BA	J23
HDIN_BB	J25
HDIP_BB	J26
HDIN_BC	J29
HDIP_BC	J30
HDIN_BD	J33
HDIP_BD	J34
HDOUTN_BA	J21
HDOUTP_BA	J24
HDOUTN_BB	J27
HDOUTP_BB	J28
HDOUTN_BB	J31
HDOUTP_BB	J32
HDOUTN_BB	J35
HDOUTP_BB	J36

Note: Outputs for channels AA and BA have on-board bias\_T's to the VDD\_OB supply. Channels AB and AC are AC coupled with 100ohm pull-up resistors to VDD\_OB. The remaining output channels and all input channels are DC coupled.

**Table 6. Clock SMA Connectors**

Jack Number	Related Schematic	Function
J38	Figure 9	External System Clock Input_P
J40	Figure 9	External System Clock Input_N
J43	Figure 10	ORSO/ORT External Ref Clk A_P Input
J44	Figure 10	ORSO/ORT External Ref Clk A_N Input
J46	Figure 10	ORSO/ORT External Ref Clk B_P Input
J47	Figure 10	ORSO/ORT External Ref Clk B_P Input
J48	Figure 10	Trigger (Clock) Out_P
J49	Figure 10	Trigger (Clock) Out_N

Notes:

- On-board header connections determine the clock source for the FPSC. The FPSC reference clocks may be provided by the onboard oscillator, a common external clock source, or multiple external clocks.
- If an external clock source is used, it must be a differential clock.
- The trigger outputs are DC coupled in the default configuration. They can be converted to AC coupling by replacing resistors R204 and R215 with 0.01  $\mu$ F surface mount capacitors.

**Table 7. OECA/PLL Clock Test SMA Connectors (see Figure 17)**

Jack Number	Function
J80	True Input, PLL Clock 0 Test
J82	Complementary Input, PLL Clock 0 Test
J83	True Input, Primary Clock 0 Test
J85	True Input, PLL Clock 1 Test
J87	Complementary Input, Primary Clock 0 Test
J88	Complementary Input, PLL Clock 1 Test
J89	True Input, Primary Clock 1 Test
J91	True Input, PLL Clock 6 Test
J93	Complementary Input, Primary Clock 1 Test
J94	Complementary Input, PLL Clock 6 Test
J95	True Input, PLL Clock 7 Test
J97	Complementary Input, PLL Clock 7 Test



**Table 8. ispGDX2 SMA Connectors (see Figure 20)**

Jack Number	Function
J104	Negative Clock Out, SS_CLKOUT0N
J105	Positive Clock Out, SS_CLKOUT0P
J106	Positive Clock In, SS_CLKIN1P
J107	Negative Clock Out, SS_CLKIN1N
J108	Positive Serial Data In, HSI2A_SINP
J109	Negative Serial Data In, HSI2A_SINN
J110	Positive Serial Data Out, HSI2A_SOUTP
J111	Negative Serial Data Out, HSI2A_SOUTN
J112	Positive Serial Data Out, HSI4B_SOUTP
J113	Negative Serial Data Out, HSI4B_SOUTN
J114	Positive Serial Data In, HSI4B_SINP
J115	Negative Serial Data In, HSI4B_SINN

**Table 9. Backplane Test SMA Connectors (see Figure 24 and areas marked "stripline" in Figure 1)**

Jack Number	Connection
J132	J133 40" backplane, 8 mil coplanar stripline
J134	J135 40" backplane, 8 mil coplanar stripline
J136	J137 24" backplane, 8 mil coplanar stripline
J138	J139 24" backplane, 8 mil coplanar stripline

All connections have 100Ω balanced impedance between pairs.

## Logic Analyzer Connections

The Logic Analyzer connections are connectors for Agilent P/N 01650-63203 isolation adapters or an equivalent. As shown in Figure 1, each connector has an associated LED that lights when a proper connection is made. See Figure 1 and Figure 8.

This 10x2 connector is used for ORSO/ORT82G5 Quad B SERDES testing (PSCHAR).

**Table 10. Logic Analyzer Connectors**

Pin	Signal	Signal	Pin
1	Ground via D3	N/C	2
3	PSCHAR_XCK	ATM_OUT_B	4
5	PSCHAR_CV	PSCHAR_BYTSYNC	6
7	PSCHAR_CKIO1	PSCHAR_WDSYNC	8
9	PSCHAR_CKIO0	PSCHAR_LDIO9	10
11	PSCHAR_LDIO8	PSCHAR_LDIO7	12
13	PSCHAR_LDIO6	PSCHAR_LDIO5	14
15	PSCHAR_LDIO4	PSCHAR_LDIO3	16
17	PSCHAR_LDIO2	PSCHAR_LDIO1	18
19	PSCHAR_LDIO0	Ground	20

**LA2 and LA3**

These 10x2 ORCA to ispGDX2 bus analyzer connectors are used for clock, control, status and reset signals for the ispGDX2 device (see Figure 20). Each pin is also connected to a general purpose I/O pin in the ORSO/ORT82G5 FPGA logic.

**Table 11. LA2 Signals**

Pin	Signal
1	Ground via D19
2	N/C
3	N/C
4	CAL
5	GOE0
6	CSLOCK4
7	SYDT2A
8	SYDT4BF
9	CDRLOCK2A
10	LOSS4B
11	RECCLK2A
12	EXLOSS4B
13	EXLOSS2A
14	RECCLK4B
15	LOSS2A
16	CDRLOCK4B
17	SYDT2AF
18	STD4B
19	CSLOCK2
20	Ground

Table 12. LA3 Signals

Pin	Signal
1	Ground via D20
2	N/C
3	N/C
4	N/C
5	N/C
6	N/C
7	GOE1
8	CDRRST2A
9	GOE2
10	CDRRST4B
11	GOE3
12	FIFO_EMPTY
13	SEL0
14	FIFO_FULL4B
15	SEL1
16	GCLKCE3
17	SEL2
18	GCLKCE2
19	SEL3
20	Ground

**LA4 and LA5**

These 10x2 ORCA to ispGDXX2 bus analyzer connectors are used for TX data, RX data and general purpose I/O signals for the ispGDXX2 device (see Figure 21). Each pin is also connected to a general purpose I/O pin in the ORSO/ORT82G5 FPGA logic.

**Table 13. LA4 Signals**

Pin	Signal
1	Ground via D21
2	N/C
3	N/C
4	GP_5
5	GP_4
6	GP_3
7	GP_2
8	GP_1
9	GP_0
10	TXD9
11	TXD8
12	TXD7
13	TXD6
14	TXD5
15	TXD4
16	TXD3
17	TXD2
18	TXD1
19	TXD0
20	Ground

**Table 14. LA5 Signals**

Pin	Signal
1	Ground via D22
2	N/C
3	N/C
4	GP_11
5	GP_10
6	GP_9
7	GP_8
8	GP_7
9	GP_6
10	RXD9
11	RXD8
12	RXD7
13	RXD6
14	RXD5
15	RXD4
16	RXD3
17	RXD2
18	RXD1
19	RXD0
20	Ground

## Power Supply Notes

The evaluation board includes five on-board regulated power supplies that operate from an external 5V supply. Headers are used to allow a choice of voltage for the on-board voltage buses, and to control the relays for either on-chip or off-chip power for each voltage level. Each supply is fused and has an associated LED indicating that the voltage is present (see Figure 1). The fuses are Littelfuse Alarm Indicating Fuses, 0481 Series (F1 is Digikey P/N F725 and the other four fuses are Digikey P/N F723).

The evaluation board also includes an ispPAC-POWR1208 power control device. Programming files for this device can be developed using Lattice PAC-Designer® software. The top level PAC-Designer screen used for the default programming of the ispPAC-POWR1208 device is shown in Figure 3.

Figure 3. PAC-Designer Configuration Interface for ispPAC-POWER1208

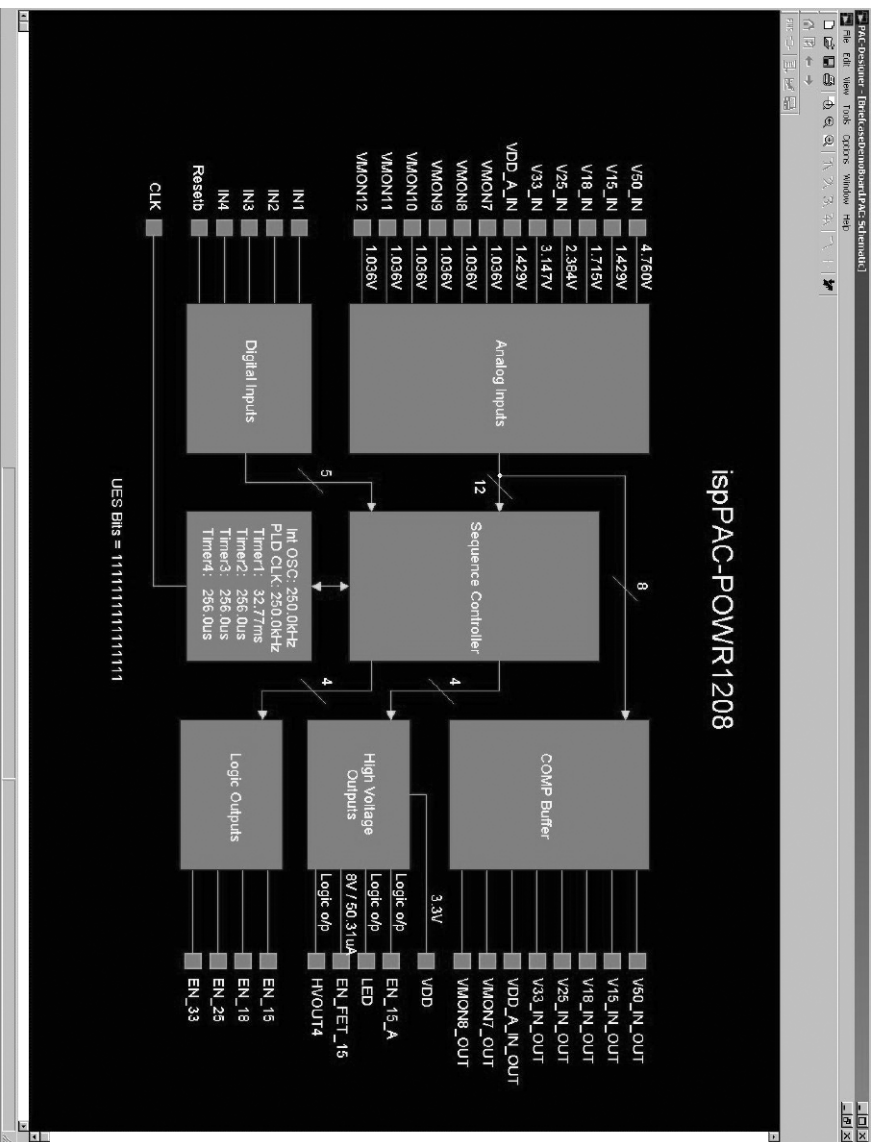

As provided, the device is programmed to provide power in the sequence shown in Figure 4.

Figure 4. Default Power Sequence for ispPAC-POWER1208 Used on the Evaluation Board

## Turret Connectors

The following turret connectors are available for monitoring the power buses on the evaluation board.

**Table 15. Turret Connectors**

Turret Number	Related Schematic	Connected to – Power Bus
T1	Figure 14	5V
T2	Figure 14	Ground
T3	Figure 14	Ground
T4	Figure 14	Ground
T5	Figure 16	3.3V, relay side of fuse
T6	Figure 16	Analog 1.5V, relay side of fuse
T7	Figure 16	3.3V, LED side of fuse
T8	Figure 16	Analog 1.5V, LED side of fuse
T9	Figure 16	2.5V, relay side of fuse
T10	Figure 16	2.5V, LED side of fuse
T11	Figure 16	1.5V, relay side of fuse
T12	Figure 16	1.8V, relay side of fuse
T13	Figure 16	1.5V, LED side of fuse
T14	Figure 16	1.8V, LED side of fuse

## Banana Jack Connectors

The following banana jack connectors are available for supplying power to the evaluation board from an external source.

**Table 16. Banana Jack Connectors**

Jack Number	Related Schematic	Color	Function
J55	Figure 14	Red	5V external supply (VDD5)
J56	Figure 14	Black	Ground (GND)
J57	Figure 14	Black	Ground (GND)
J59	Figure 14	Black	Ground (GND)
J72	Figure 16	Red	Analog 1.5V external supply (VDDA)
J73	Figure 16	Red	3.3V external supply (VDD33)
J75	Figure 16	Red	2.5V external supply (VDD25)
J78	Figure 16	Red	1.5V external supply (VDD15)
J79	Figure 16	Red	1.8V external supply (VDD18)
J99	Figure 18	Red	VDD_OB external supply (located beneath DIP switches)
J101	Figure 18	Red	VDD_IB external supply (located beneath DIP switches)
J103	Figure 18	Red	VDDA external supply (located beneath DIP switches)
J119	Figure 22	Red	ispGDX2 VCC external supply
J131	Figure 23	Red	ispGDX2 VCCP (analog) external supply

## J58

A 2.5 mm male power jack (J58) is provided for connection to the 5V wall power adapter (Condor SA-054A00-1-2061P or equivalent). See Figure 14.

## Diodes

The following diodes are used on the evaluation board.

**Table 17. Diodes**

Diode Number	Related Schematic	Type	Function/Indication
D1	Figure 6	Red LED	ORSO/ORT82G5 Configuration INIT
D2	Figure 6	Green LED	ORSO/ORT82G5 Configuration DONE
D3	Figure 8	Yellow LED	ORSO/ORT82G5 SERDES Test LA Pod OK
D4	Figure 11 <sup>1</sup>	Quad Red LED	Outputs from ORSO/ORT82G5 FPGA Logic
D5	Figure 11 <sup>1</sup>	Quad Red LED	Outputs from ORSO/ORT82G5 FPGA Logic
D6	Figure 11 <sup>1</sup>	Quad Red LED	Outputs from ORSO/ORT82G5 FPGA Logic
D7	Figure 11 <sup>1</sup>	Quad Red LED	Outputs from ORSO/ORT82G5 FPGA Logic
D8	Figure 12	1N4148	Voltage dropping diode, parallel port input
D9	Figure 12	Green LED	USB Interface Active
D10	Figure 14	Green LED	5V (VDD5) present on evaluation board
D11	Figure 14	1N4148	ispPAC VDD bias network
D12	Figure 14	Green LED	ispPAC Configuration Done
D13	Figure 14	1N5226	ispPAC VDD bias network, Zener
D14	Figure 16	Green LED	3.3V (VDD33) present on evaluation board
D23	Figure 16	Green LED	Analog 1.5V (VDDA) present on evaluation board
D16	Figure 16	Green LED	2.5V (VDD25) present on evaluation board
D24	Figure 16	Green LED	1.5V (VDD15) present on evaluation board
D25	Figure 16	Green LED	1.8V (VDD18) present on evaluation board
D19	Figure 20	Yellow LED	ORCA to ispGDX2 Test LA Pod 2 OK
D20	Figure 20	Yellow LED	ORCA to ispGDX2 Test LA Pod 3 OK
D21	Figure 21	Yellow LED	ORCA to ispGDX2 Test LA Pod 4 OK
D22	Figure 21	Yellow LED	ORCA to ispGDX2 Test LA Pod 5 OK

1. Also see LED and DIP table (Table 19).



## Switches

The following switches are used on the evaluation board.

**Table 18. Switches**

Switch Number	Related Schematic	Type	Function
SW1	Figure 6	Momentary PB	ORSO/ORT82G5 RESETN
SW2	Figure 6	Momentary PB	ORSO/ORT82G5 PRGMN
SW3[A:D]	Figure 11 <sup>1,2</sup>	Quad DIP	Switch Inputs to ORSO/ORT82G5 FPGA Logic
SW4[A:D]	Figure 11 <sup>1,2</sup>	Quad DIP	Switch Inputs to ORSO/ORT82G5 FPGA Logic
SW5[A:D]	Figure 11 <sup>1,2</sup>	Quad DIP	Switch Inputs to ORSO/ORT82G5 FPGA Logic
SW6[A:D]	Figure 11 <sup>1,2</sup>	Quad DIP	Switch Inputs to ORSO/ORT82G5 FPGA Logic
SW7	Figure 13	Momentary PB	ORSO/ORT82G5 PASB_RESETN (SERDES Test)
SW8	Figure 14	SPDT	Disconnects +5 volts from evaluation board
SW11	Figure 14	Momentary PB	PWR1208 RESET
SW9	Figure 20	Momentary PB	GDX-RESET4B
SW10	Figure 20	Momentary PB	GDX-RESET2A

1. Also see the LED and DIP table (Table 19).

2. For the Quad DIP switches, "off" is toward the banana jacks.

## LED and DIP Connections to ORSO/ORT82G5

**Table 19. LED and DIP Connectors**

FPGA Logic Options from ORSO/ORT82G5		FPGA Logic Inputs to ORSO/ORT82G5	
FPSC Pin	LED	DIP Switch	FPSC Pin
C21	D4 - Pin 2	SW3A	AL18
E18	D4 - Pin 4	SW3B	AN21
E19	D4 - Pin 6	SW3C	AM21
D19	D4 - Pin 8	SW3D	AN22
D20	D5 - Pin 2	SW4A	AK18
B24	D5 - Pin 4	SW4B	AN23
C23	D5 - Pin 6	SW4C	AP26
C22	D5 - Pin 8	SW4D	AK19
C24	D6 - Pin 2	SW5A	AL21
A27	D6 - Pin 4	SW5B	AM23
B27	D6 - Pin 6	SW5C	AN25
B25	D6 - Pin 8	SW5D	AL22
B26	D7 - Pin 2	SW6A	AL23
A28	D7 - Pin 4	SW6B	AN27
D22	D7 - Pin 6	SW6C	AM25
E22	D7 - Pin 8	SW6D	AP29

## Ordering Information

Description	Ordering Part Number	China RoHS Environment-Friendly Use Period (EFUP)
ORT82G5, ispGDx256, and ispPAC Power Manager 1208 Briefcase Board	ORT82G5-G2-PAC-EV	
ORSO82G5 Evaluation Board	ORSO82G5-G2-PAC-EV	

## Technical Support Assistance

Hotline: 1-800-LATTICE (North America)

+1-503-268-8001 (Outside North America)

e-mail: [techsupport@latticesemi.com](mailto:techsupport@latticesemi.com)

Internet: [www.latticesemi.com](http://www.latticesemi.com)

## Revision History

Date	Version	Change Summary
March 2003	01.0	Initial release.
March 2007	01.1	Added Ordering Information section.

© 2007 Lattice Semiconductor Corp. All Lattice trademarks, registered trademarks, patents, and disclaimers are as listed at [www.latticesemi.com/legal](http://www.latticesemi.com/legal). All other brand or product names are trademarks or registered trademarks of their respective holders. The specifications and information herein are subject to change without notice.

### Appendix A. Schematics

The current schematics for the High-Speed SERDES Briefcase Board are given in this appendix.

Figure 5. Lattice High-Speed SERDES Briefcase Board Schematic

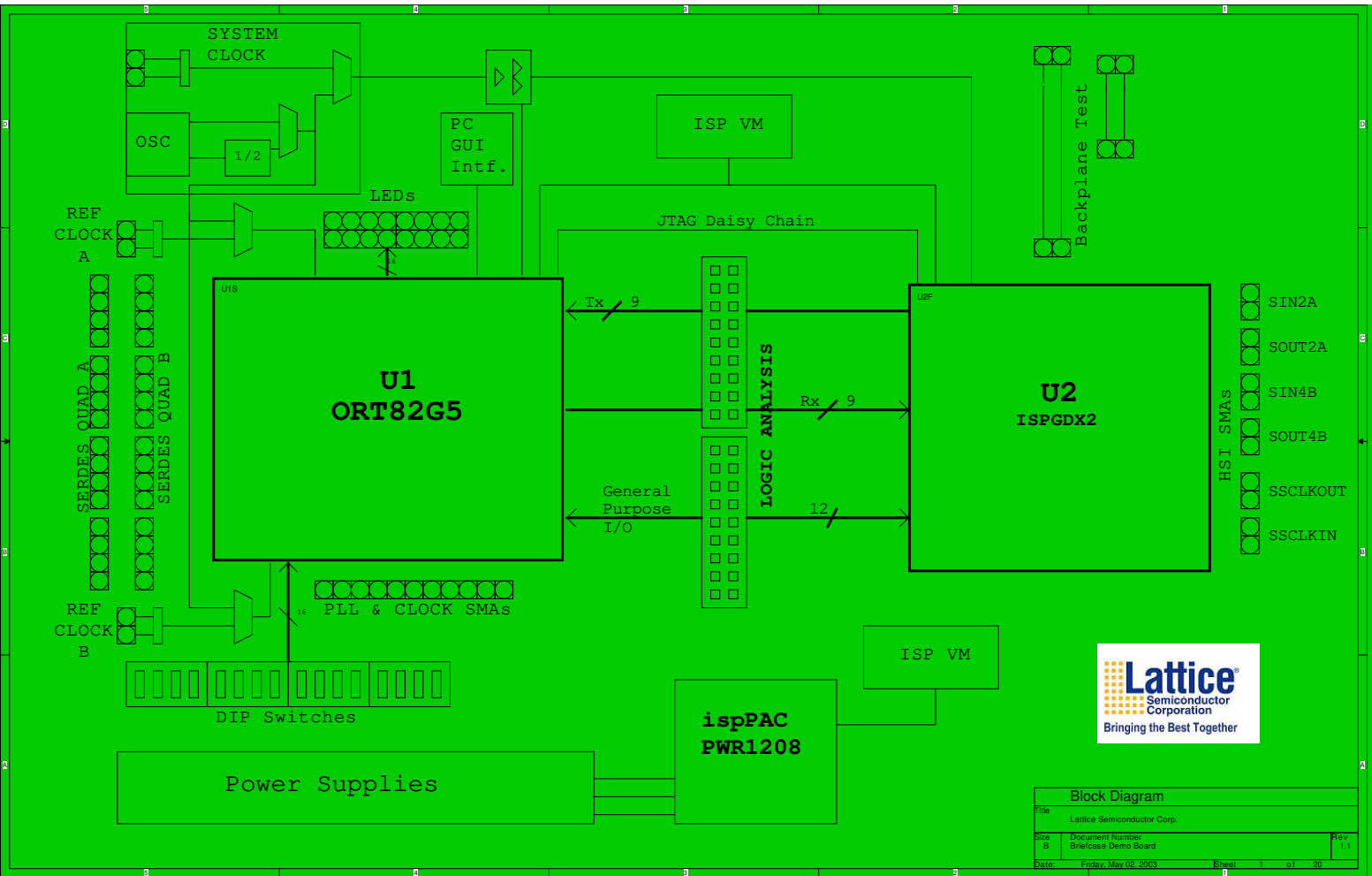

Figure 6. Lattice High-Speed SERDES Briefcase Board Schematic

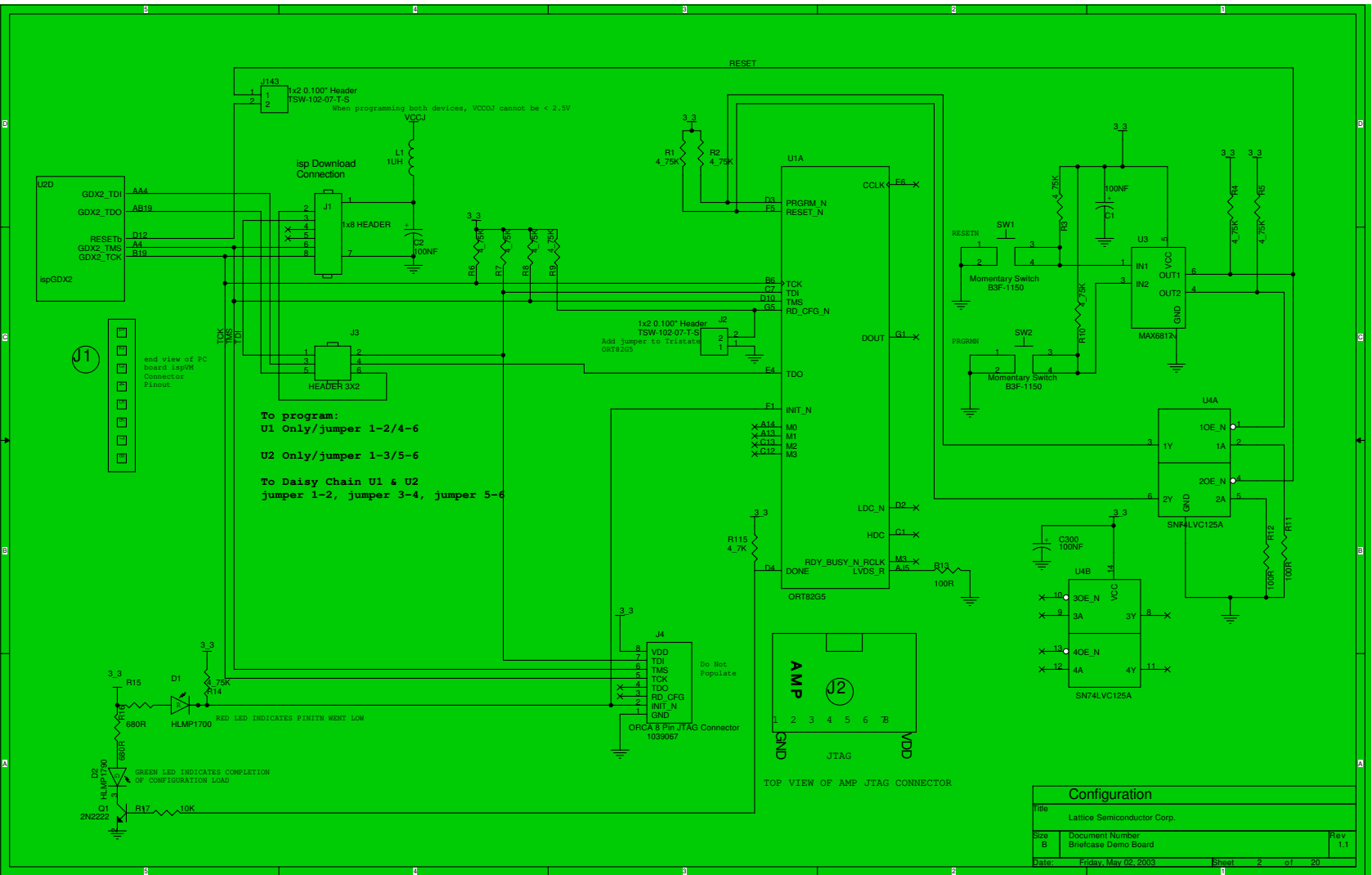

Figure 7. Lattice High-Speed SERDES Briefcase Board Schematic

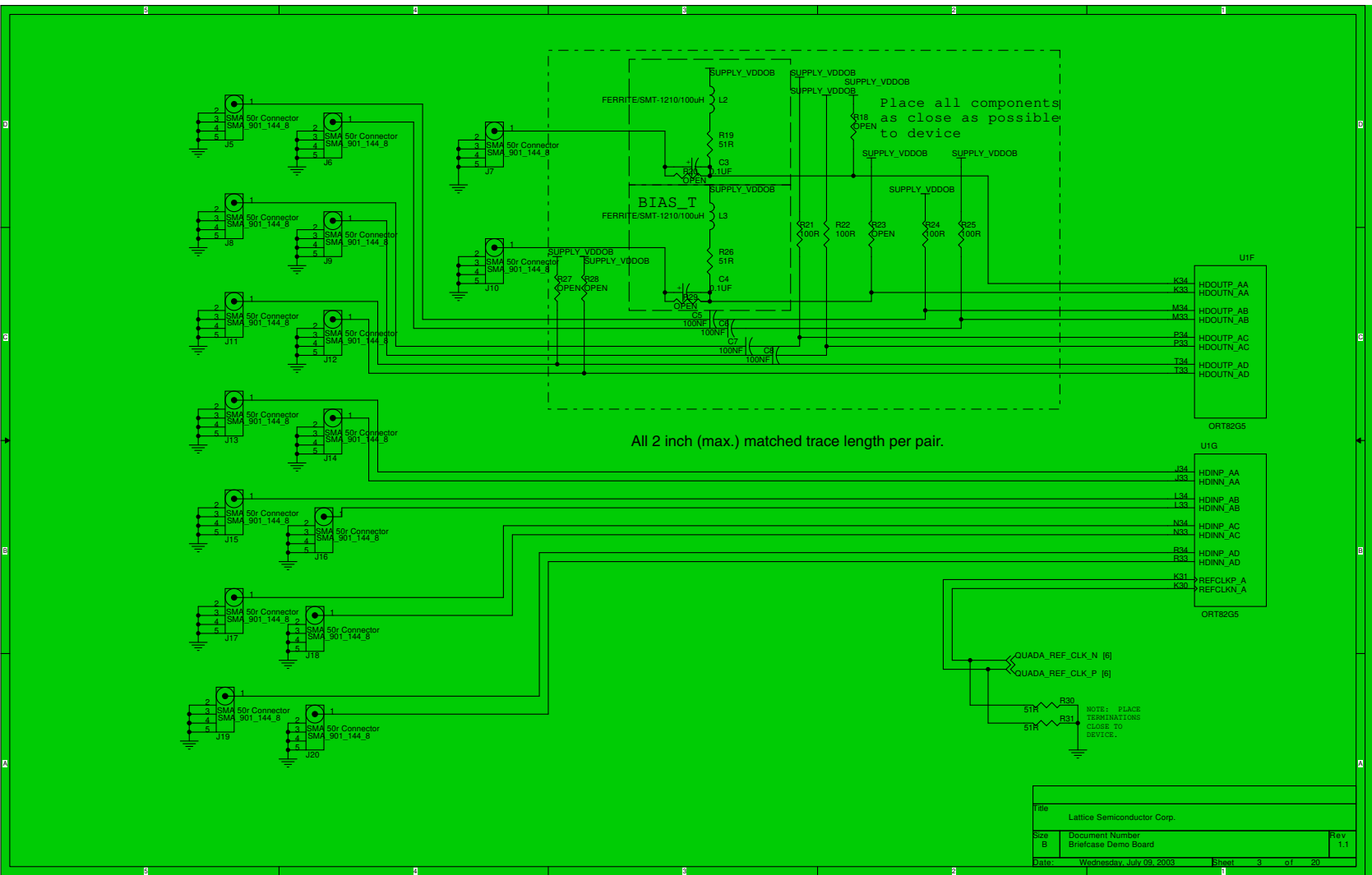

Figure 8. Lattice High-Speed SERDES Briefcase Board Schematic

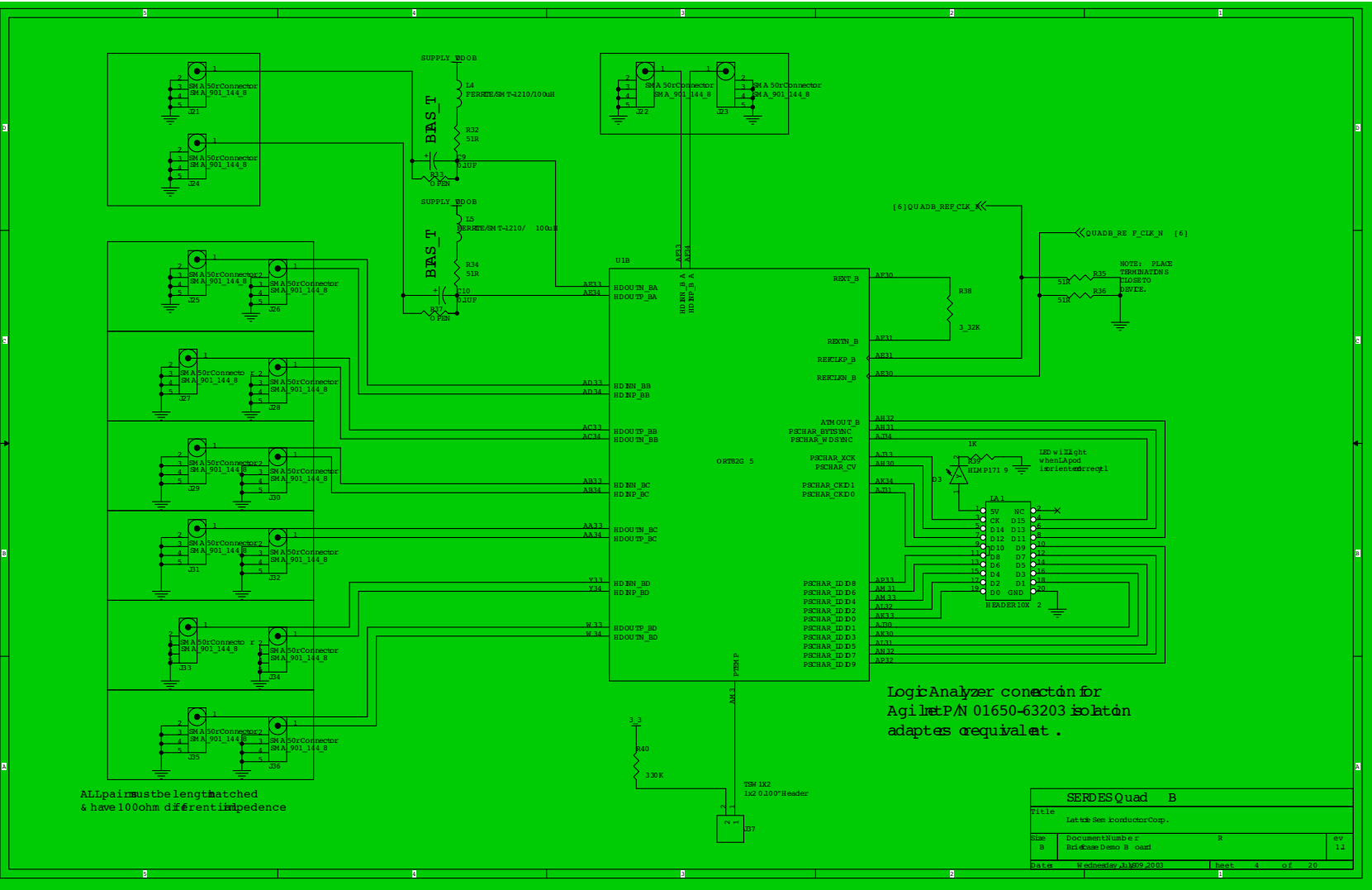

Figure 9. Lattice High-Speed SERDES Briefcase Board Schematic

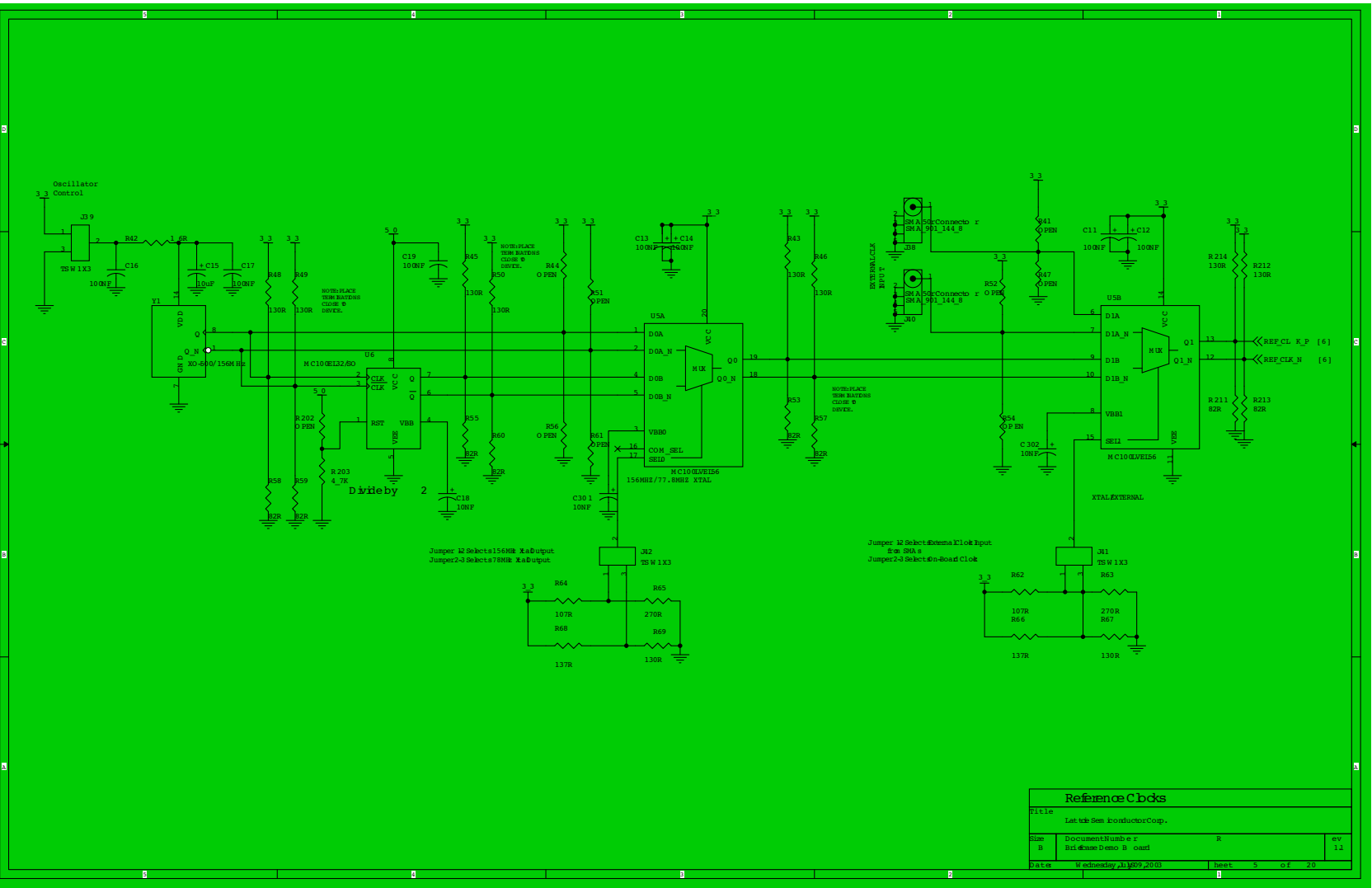

Figure 10. Lattice High-Speed SERDES Briefcase Board Schematic

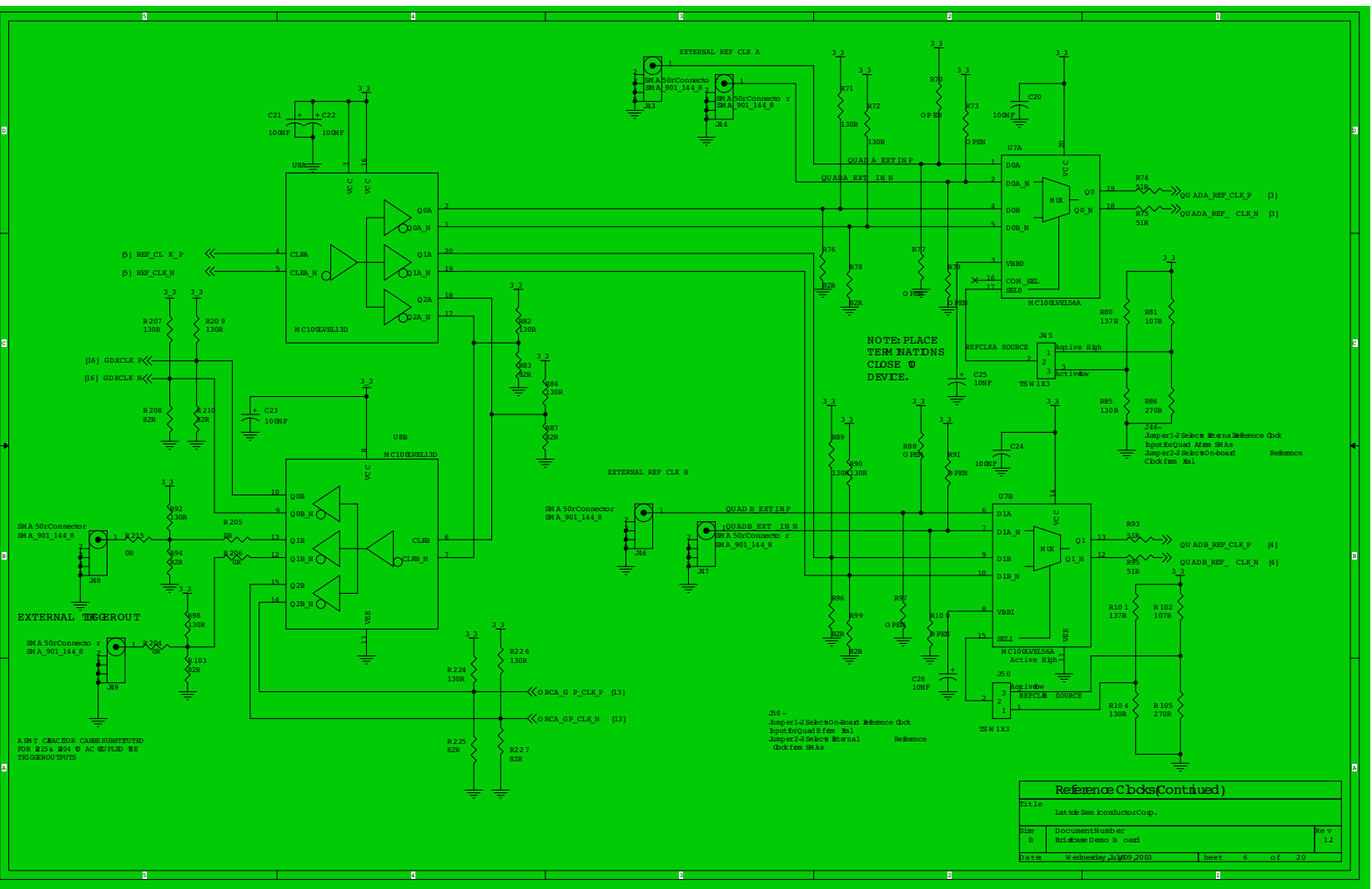



Figure 11. Lattice High-Speed SERDES Briefcase Board Schematic

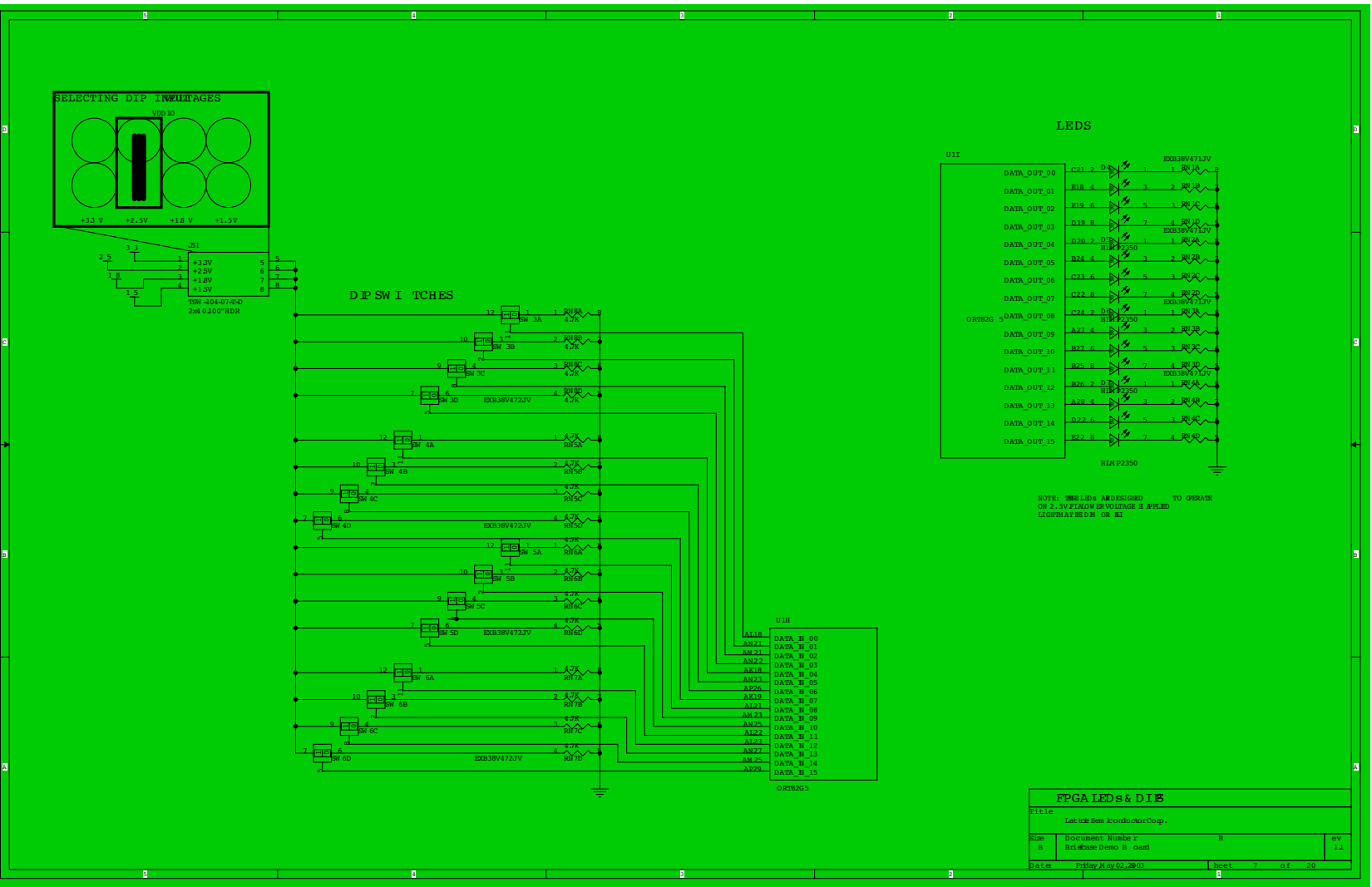

Figure 12. Lattice High-Speed SERDES Briefcase Board Schematic

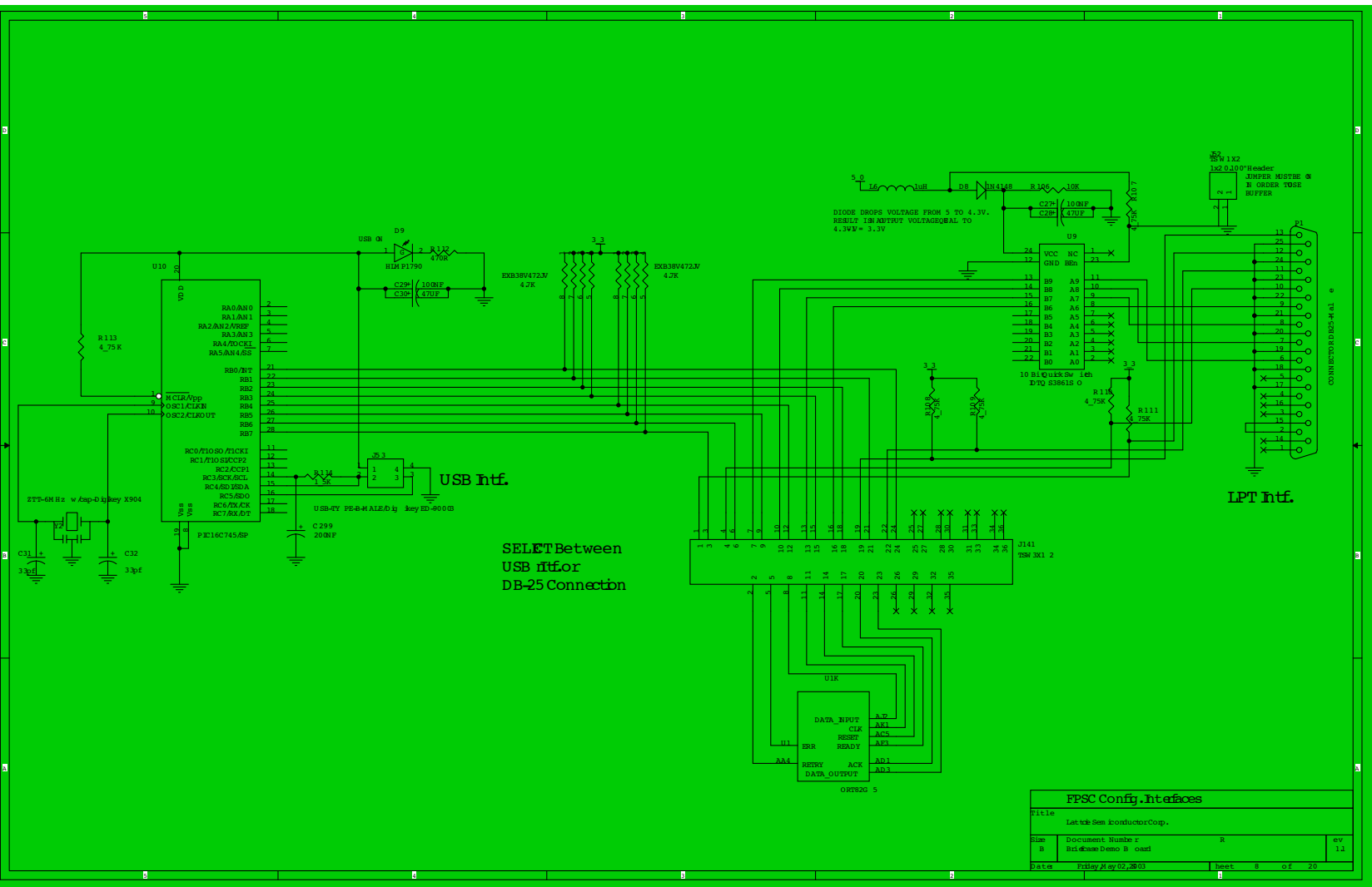

Figure 13. Lattice High-Speed SERDES Briefcase Board Schematic

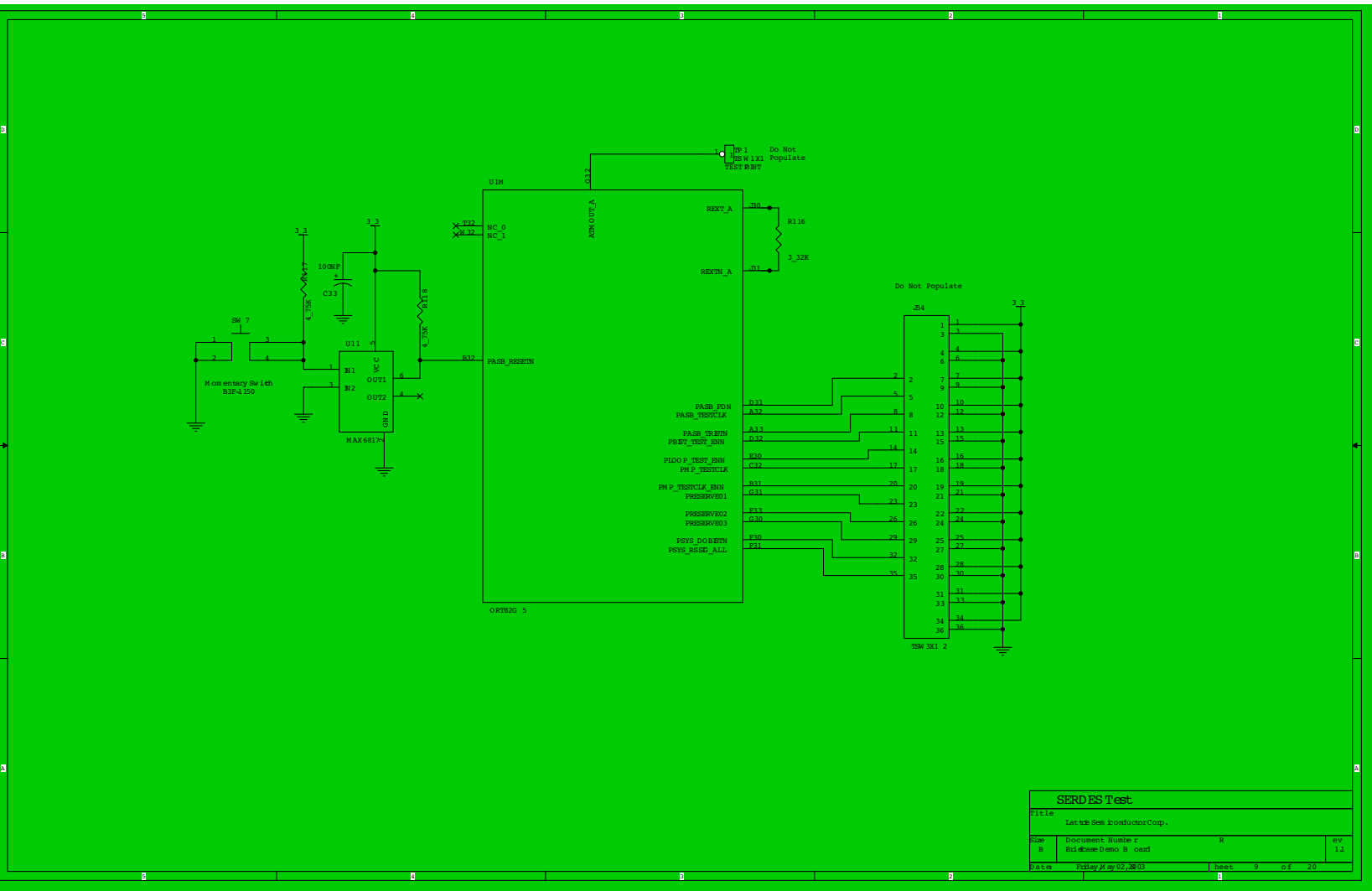

Figure 14. Lattice High-Speed SERDES Briefcase Board Schematic

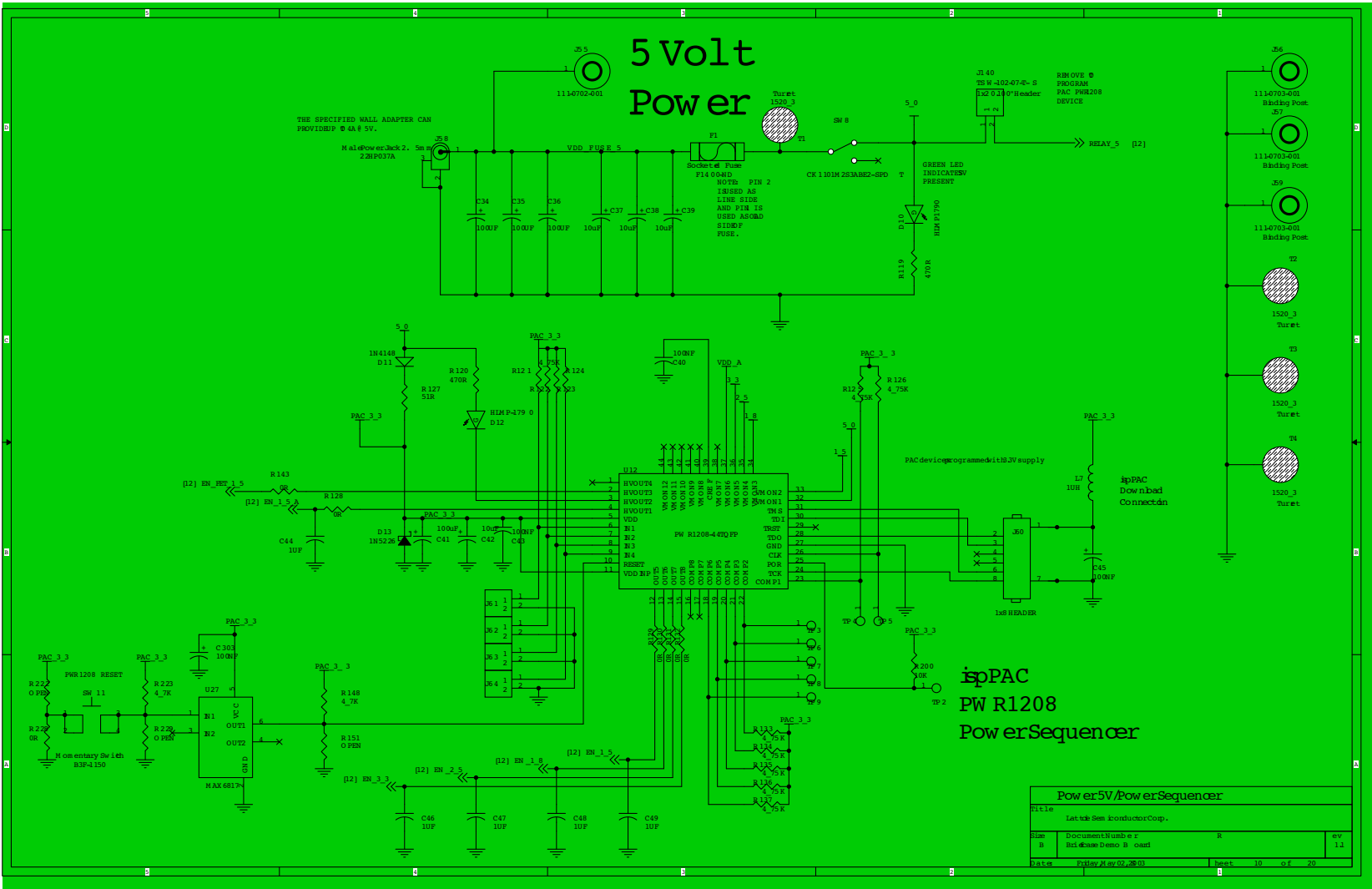

Figure 15. Lattice High-Speed SERDES Briefcase Board Schematic

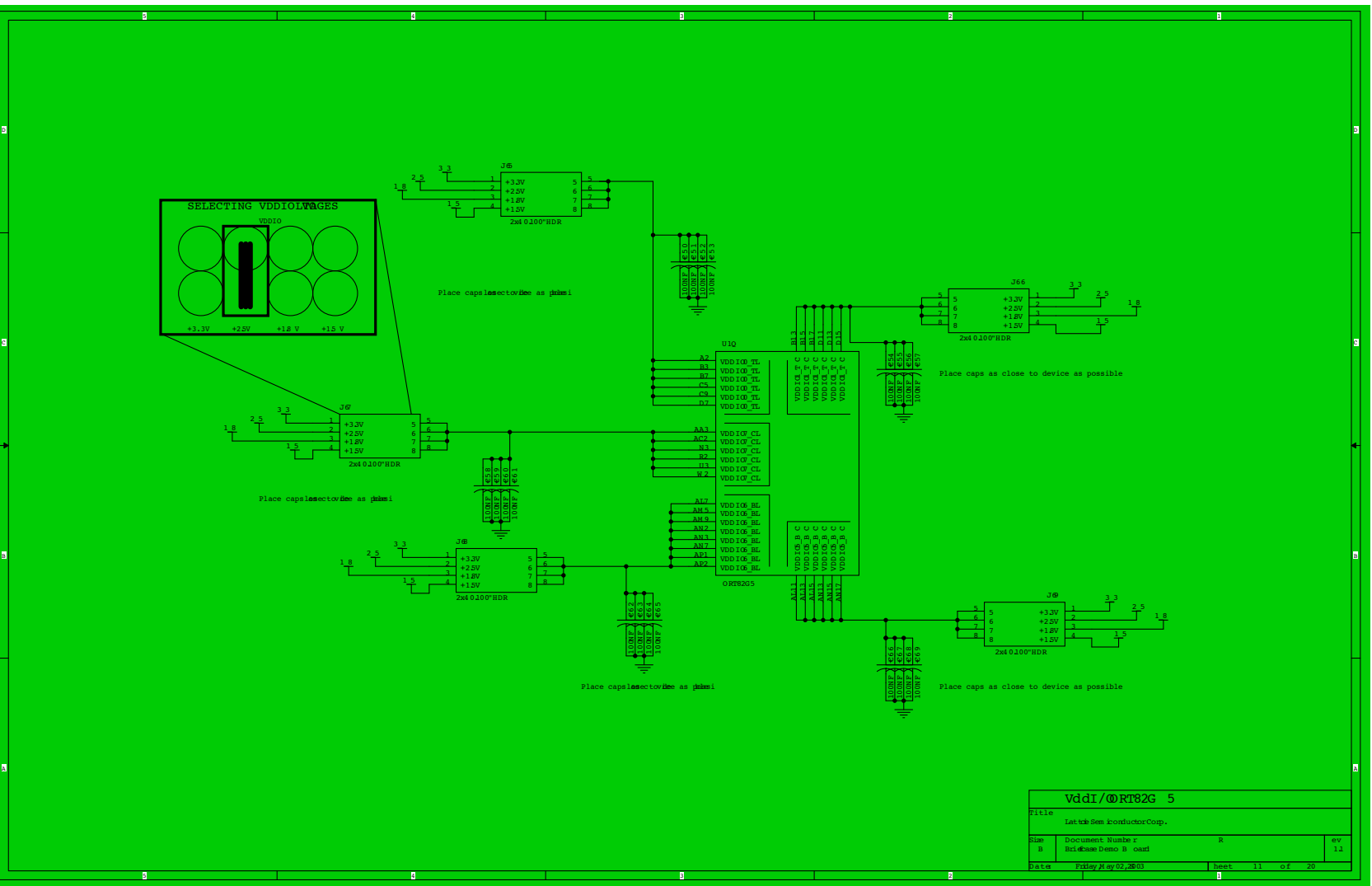

Figure 16. Lattice High-Speed SERDES Briefcase Board Schematic

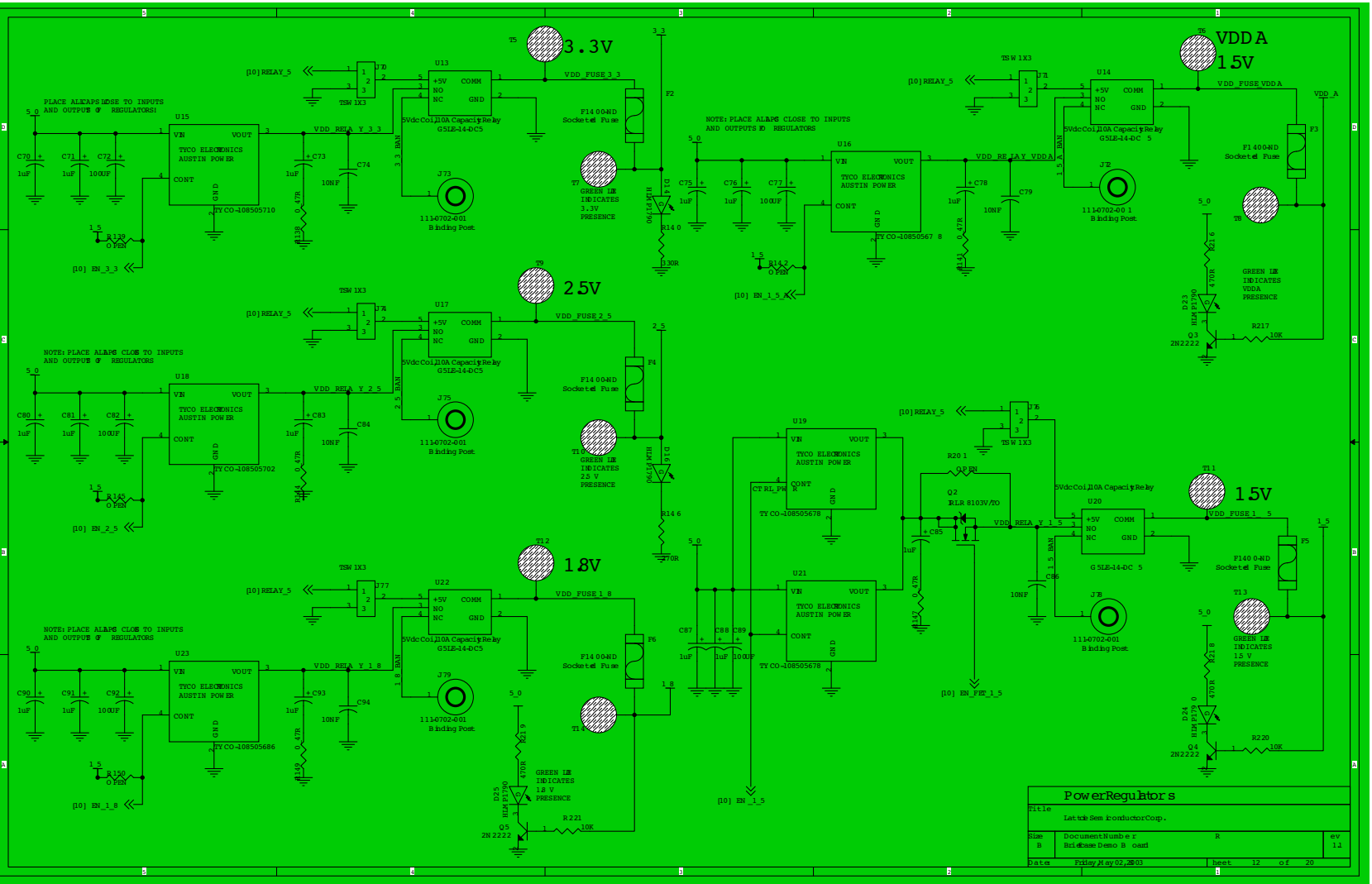

Figure 17. Lattice High-Speed SERDES Briefcase Board Schematic

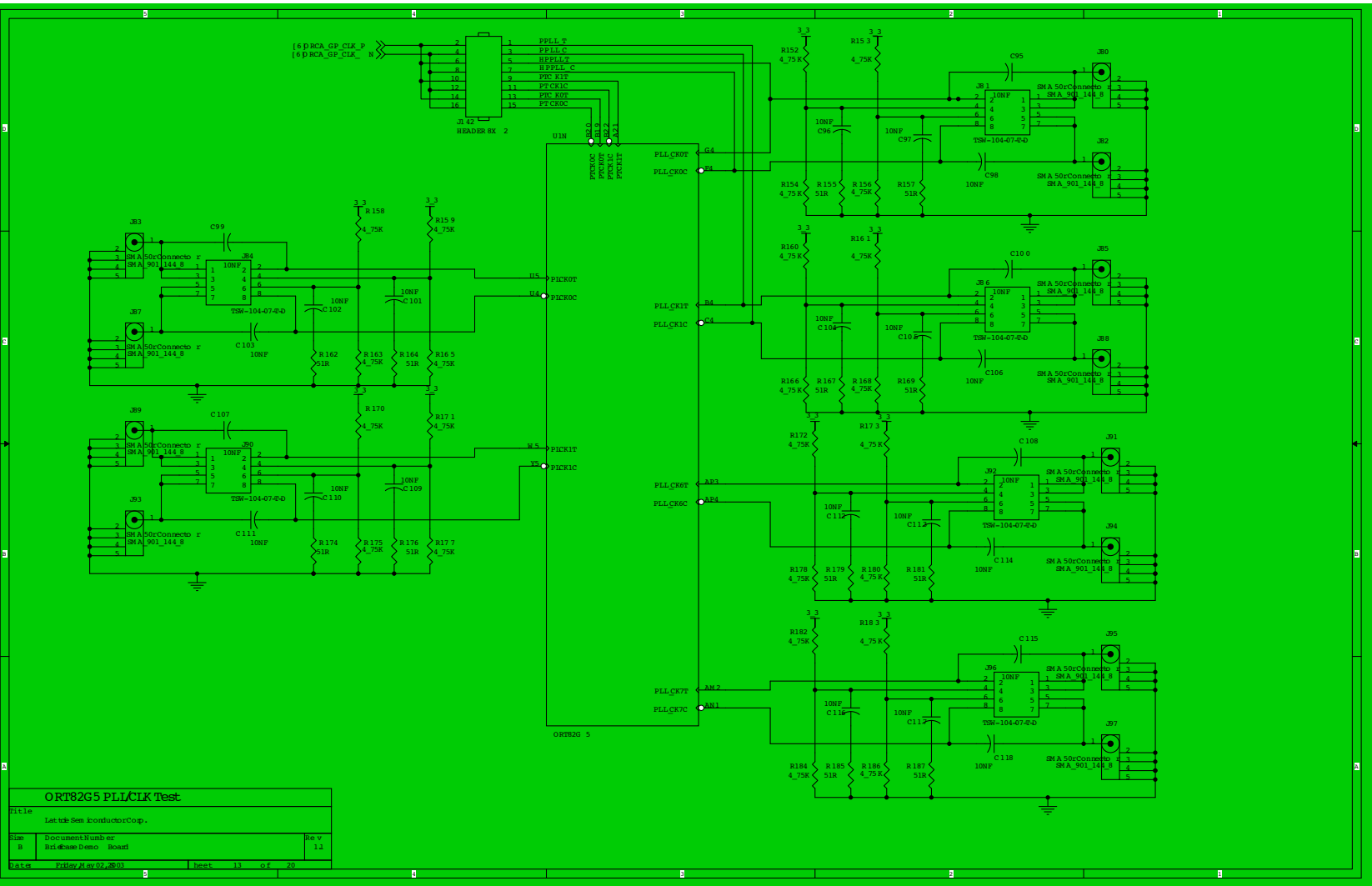

Figure 18. Lattice High-Speed SERDES Briefcase Board Schematic

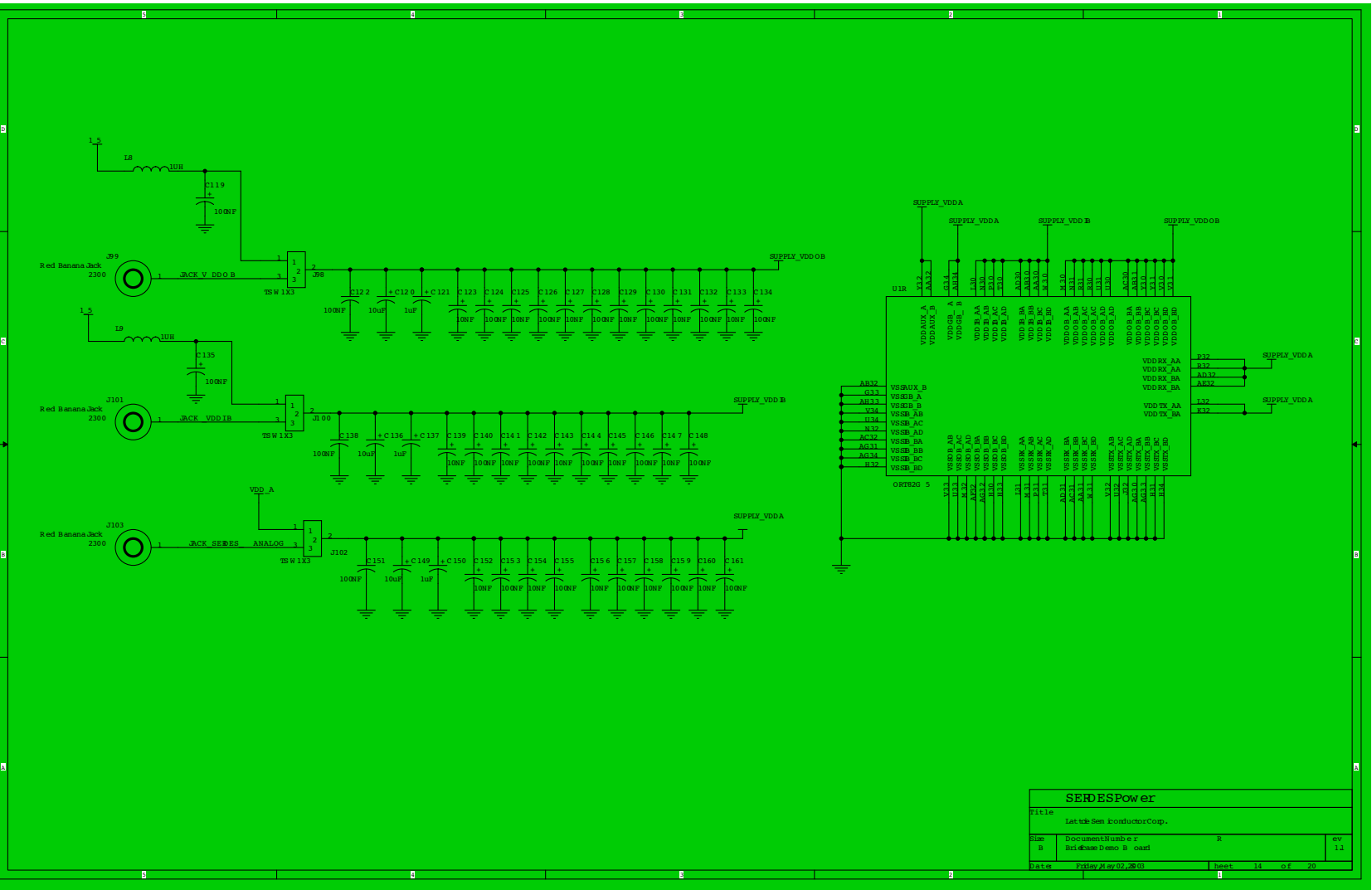



Figure 19. Lattice High-Speed SERDES Briefcase Board Schematic

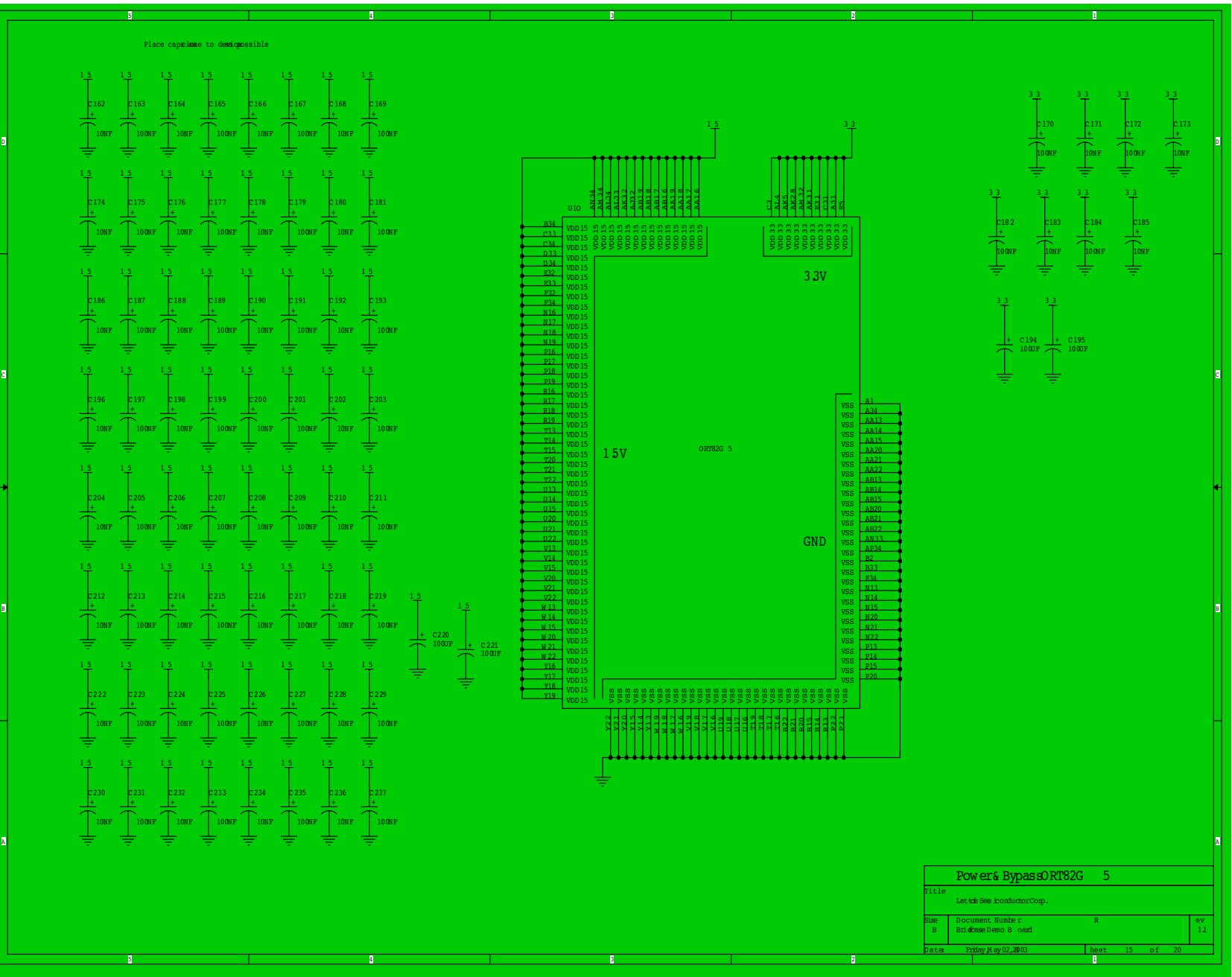

Figure 20. Lattice High-Speed SERDES Briefcase Board Schematic

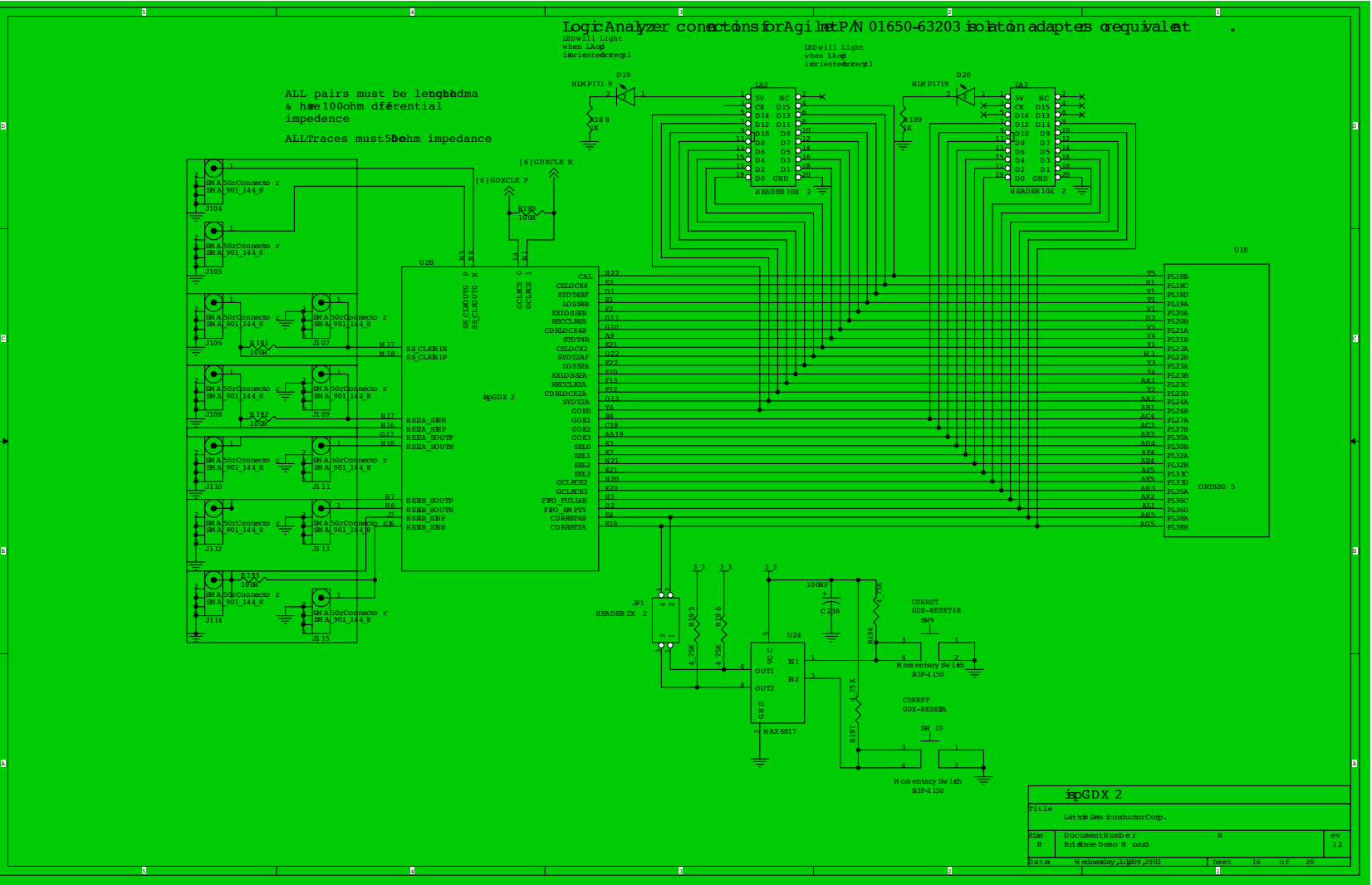



Figure 22. Lattice High-Speed SERDES Briefcase Board Schematic

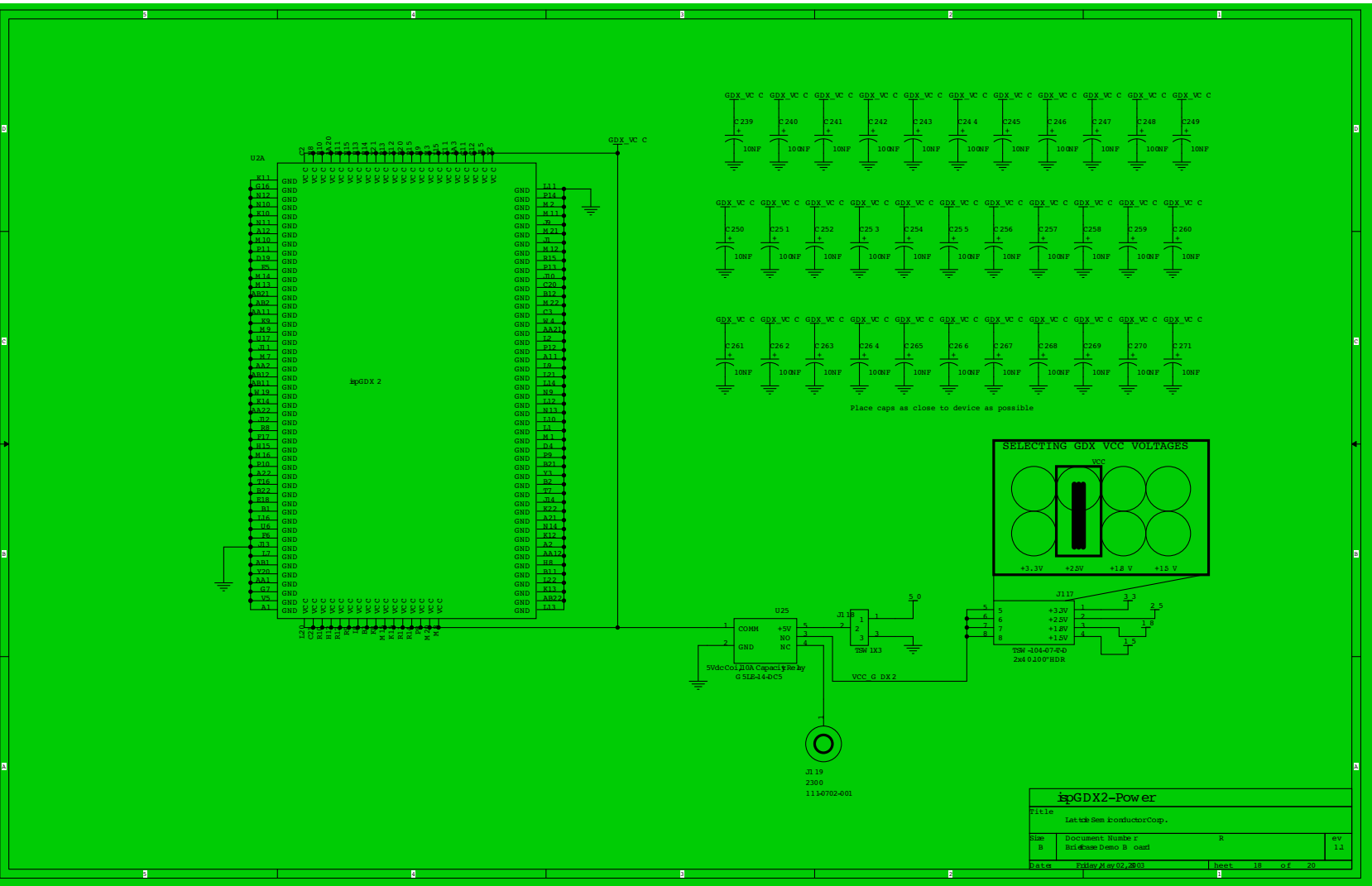

Figure 23. Lattice High-Speed SERDES Briefcase Board Schematic

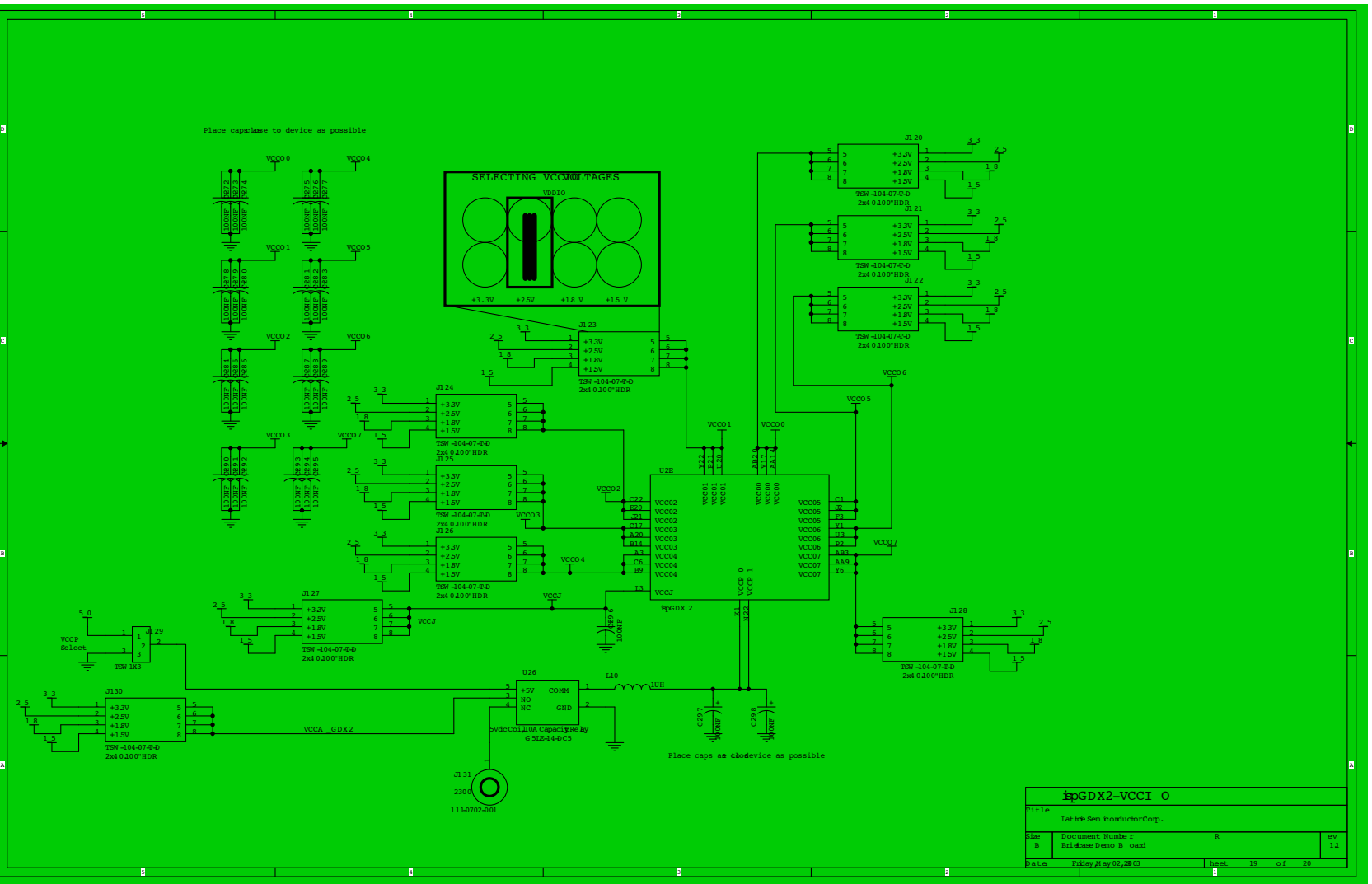

Figure 24. Lattice High-Speed SERDES Briefcase Board Schematic

