

| | | | | | | | | | | | | | | | | | | | | | | | | | | | | | | | |
|----------|----|----|----|----|----|----|----|----|----|----|----|----|----|----|----|----|----|----|----|----|----|----|----|----|----|----|----|----|----|----|----|
| GEN. ST. | 01 | 02 | 03 | 04 | 05 | 06 | 07 | 08 | 0D | 50 | 60 | 70 | 80 | 90 | | | | | | | | | | | | | | | | | |
| INT. ST. | 10 | 11 | 12 | 13 | 14 | 18 | 20 | 31 | 32 | 33 | 34 | 38 | 39 | 40 | 42 | 43 | 44 | 45 | 46 | 48 | 56 | 70 | 72 | 73 | 75 | 76 | 81 | 82 | 83 | 84 | 88 |

| REV. | DATE | DESCRIPTION | BY | C'K'D' |
|------|------------|-------------------------|-------|--------|
| E | 2012-05-14 | ELX-I-011617 (112-0024) | ALEX | ALEX |
| C | 2005-10-25 | 105-0201 | VIVEK | BKP |
| D | 2006-07-06 | 106-0096 | VIVEK | BKP |

LOADING PATTERN MATING SIDE

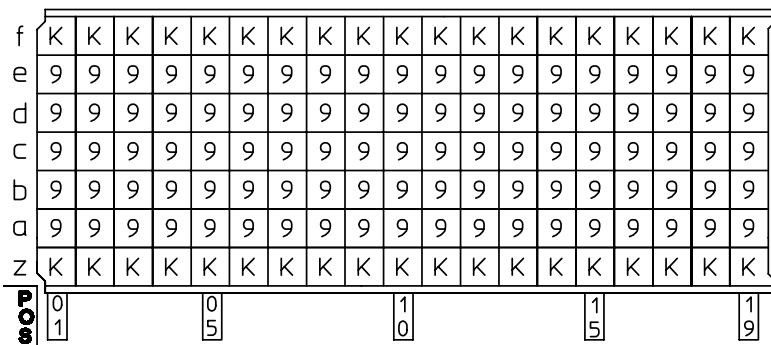

LOADED CONNECTOR ASSEMBLY (FOR EXAMPLE)

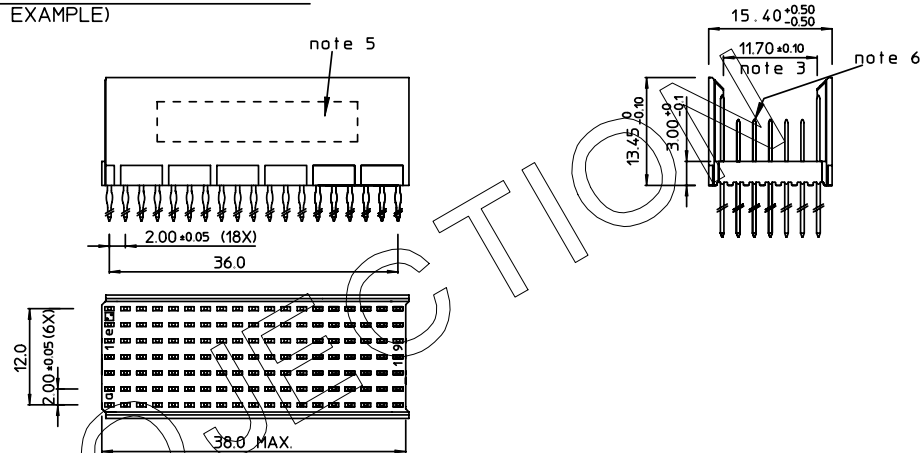

SHEET NR. : 329

CONTACT OVERVIEW

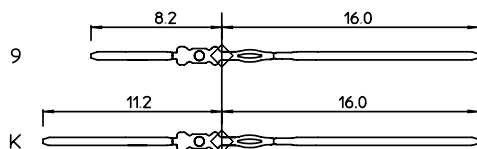

LAY-OUT P.C.B.-HOLE

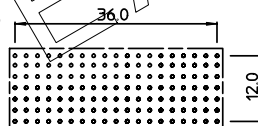

SEATING PLANE FOR CONNECTOR

LEAD FREE INDICATOR : LF = LEAD FREE (DIGIT 15 & 16)

HM2P71PN5114

PLATING CODE (DIGIT 13 AND 14) (REF DWG No. BS,C ,201844,003)

NOTES:

1. THIS PRODUCT IS CSA APPROVED.
2. THIS PRODUCT IS UL RECOGNIZED.
3. MEASURED AT THE BOTTOM.
4. MATERIAL CONTACT: PHOSPHORBRONZE
HOUSING: CREAM WHITE GLASSFILLED POLYESTER UL-94V0
5. CONNECTOR PRINTED WITH P/N AND DATE CODE.
6. FOR ACTUAL CONTACT LOADINGS, SEE LOADING PATTERN MATING SIDE.
7. SHAPE OF CONNECTOR HOUSING CAN ALTER DEPENDING ON PRODUCTION LOCATION.
8. THE PRODUCT (LF) MEETS EUROPEAN UNION DIRECTIVES AND OTHER COUNTRY REGULATIONS AS DESCRIBED IN GS-22-008
9. FOR RECOMMENDED PTH DIMENSIONS REFER DRAWING : BS,A ,201572.001

| | | | | |
|---|---------------|------------|--------|---------------------------|
| 1DEC ±0,2 2DEC ±0,1 ANGLES ±1° | APPR. | DATE | SIGN. | LOADING PATTERN OVERVIEW |
| | DRAFT | 1998-07-07 | M.Fret | CAT. No. HM2P71PN5114---- |
| WE RESERVE THE RIGHT TO CHANGE DIMENSIONS OR REQUIREMENTS WITHOUT PRIOR NOTICE. | CHECKED | | | FCJ www.fciconnect.com |
| | PR. ENG. MGR. | | | |
| ALL DIMENSIONS IN MM | PR. MGT. MGR. | | | SCALE |
| REFERENCES | | | | BS,C ,201843,181 |
| PDS: Rev :E | | | | E |