

PRE - ASSEMBLY INSTRUCTIONS:

Caution: Check gasket on top of base unit for damage before assembly. If cut or torn, contact Hammond Manufacturing for immediate replacement.

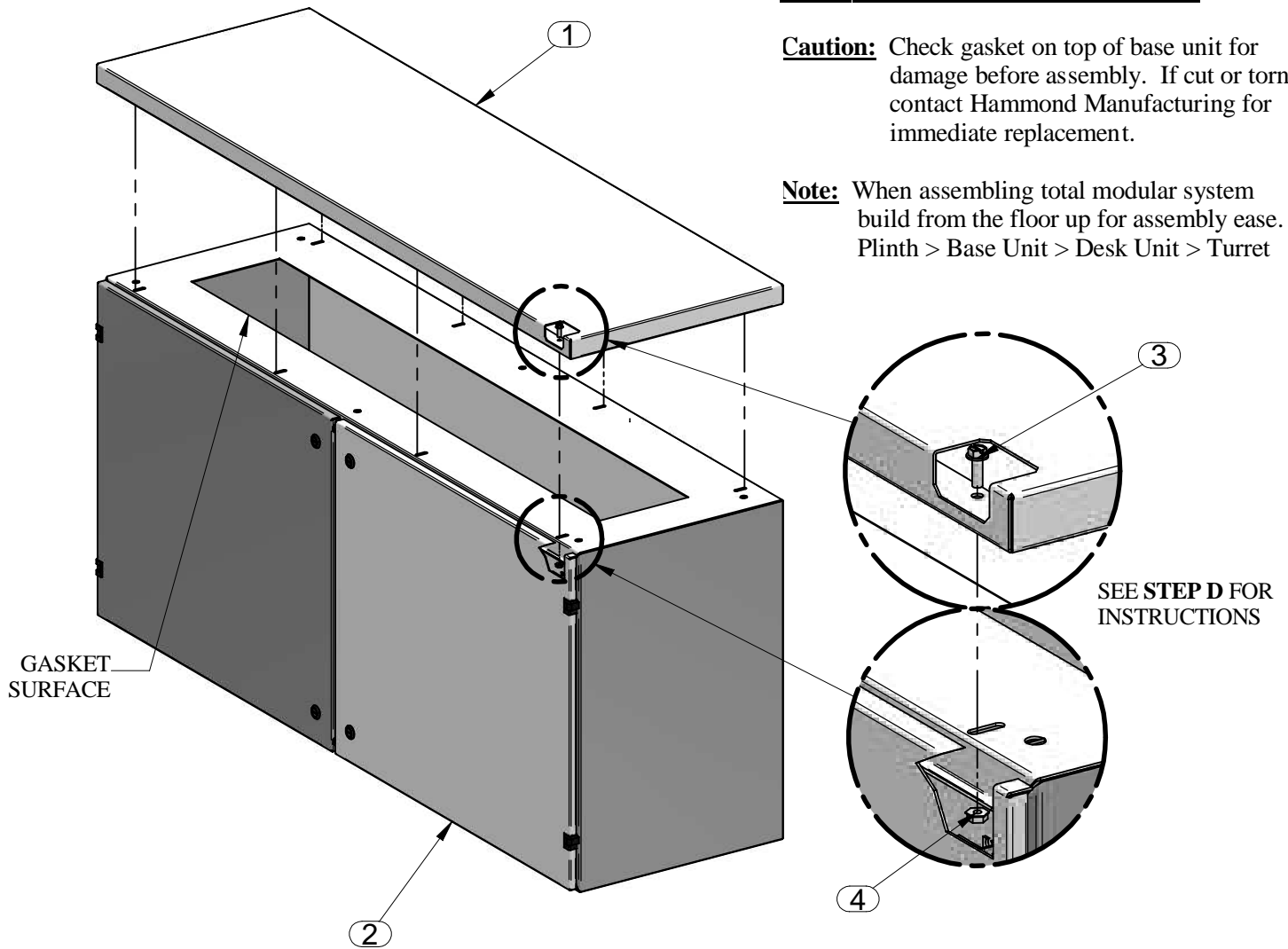

Note: When assembling total modular system build from the floor up for assembly ease. Plinth > Base Unit > Desk Unit > Turret



ASSEMBLY INSTRUCTIONS:

- A) Open or remove doors for ease of assembly. This will allow for visual alignment of mating parts. Avoid handling or hitting gasket on objects.
- B) Align base cover (item 1) over top opening in base unit (item 2). Side edges of cover and base unit are to be flush.
- C) Front and rear holes in base cover bottom are to be aligned with mounting slots on base top
- D) Once the base cover is seated properly on the base, assemble using 1/4-20 x .75 hex hd. screws and 1/4-20 nuts (item 3 & 4) provided. Torque screws and nuts to 115 in/lbs.

PARTS LIST		
ITEM No.	DESCRIPTION	QTY
1	BASE COVER	1
2	BASE UNIT	1
3	1/4-20 X 3/4 HEX CAP SCREW	4, 6, or 8
4	1/4-20 KEP NUT	4, 6, or 8

TOOL BOX 	3/8, 7/16" Socket Wrench 	3/8, 7/16 Open Wrench 
--	---	--

