

## Si4831/35/36/20/24/25-DEMO BOARD TEST PROCEDURE

### 1. Introduction

This document describes the test procedures for the Si4831/35/36/20/24/25-DEMO AM/FM/SW tuner board. It is also intended to enable customers to exactly replicate Silicon Laboratories' test environment so that variances in customers' and Silicon Laboratories' measured results can be accurately compared. This document covers FM, AM, and SW tests for the Si4831/20 and Si4835/36/24/25 receiver.

The Si4831/35/36/20/24/25-DEMO board provides a platform to test and operate the Si4831/35/36/20/24/25 tuner. Refer to the Si4831/35/36/20/24/25 DEMO Board User's Guide for the operation details of the demo board.

### 2. FM Tuner Testing Setup

#### 2.1. FM Common Setup

FM tuner standard configuration:

- Tune exactly to 98.0 MHz; see the Si4831/35/36/20/24/25 DEMO Board User's Guide for details.
- Set volume to maximum unless otherwise specified.
- Ensure cable length between the generator and antenna input is as short as possible.

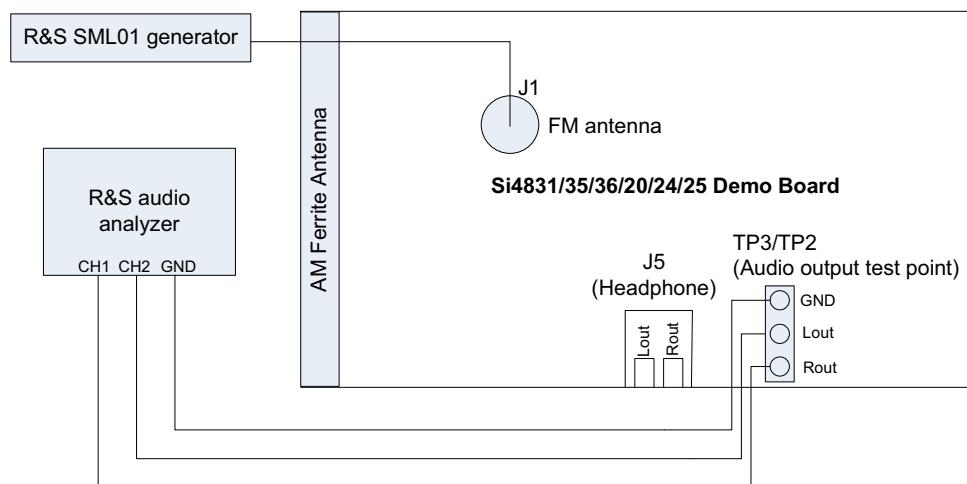
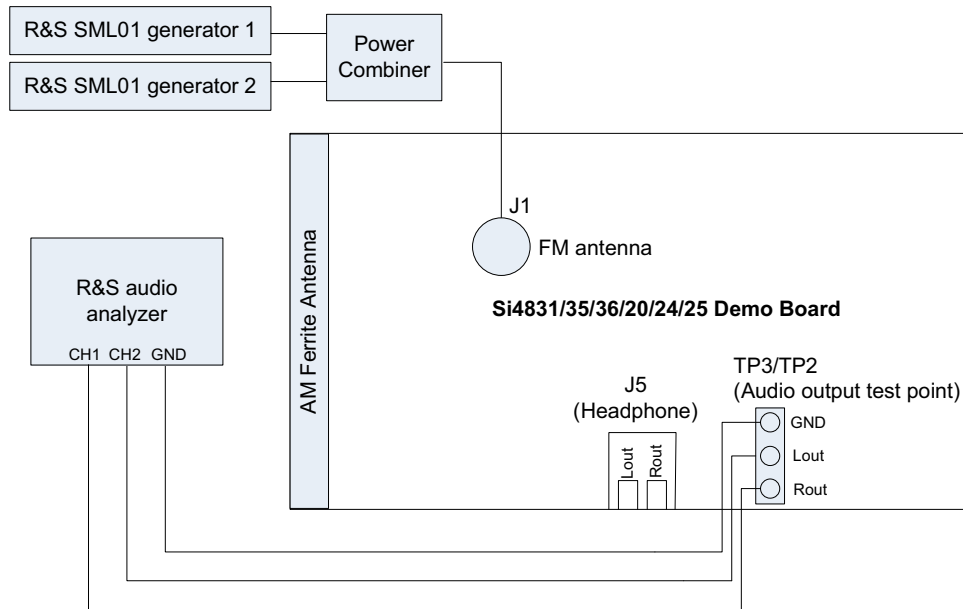

Figure 1. FM Tuner Setup with One Generator



**Figure 2. FM Tuner Setup with Two Generators**

FM tuner test equipment lists:

- Rohde & Schwarz UPL Audio Analyzer.
- Rohde & Schwarz SML01 Signal Generator
- Mini-Circuits Power Combiner

## 2.2. FM Tuner Testing Considerations

Several issues must be considered to make accurate measurements.

First, the power combiner and cable losses must be calibrated and factored into each measurement. The loss for the Mini-Circuit power combiner is approximately 6 dB.

Second, most signal generators display the voltage generated at the input of the device under test (DUT), assuming an input resistance of  $50\ \Omega$ . For example, if the signal generator displays  $V_L = 1\ \mu\text{V}$  (0 dB $\mu\text{V}$ ), the generator source voltage  $V_S$  is  $2\ \mu\text{V}$  (6 dB $\mu\text{V}$ ). The load voltage  $V_L$  is generated from the source voltage  $V_S$  by the voltage divider created by the  $50\ \Omega$  generator source resistance  $R_S$  and the  $50\ \Omega$  load resistance  $R_L$ . This distinction is important only for sensitivity, and IP3, which are specified in  $\mu\text{V EMF}^*$ , where EMF refers to the source voltage  $V_S$ . Measurements such as AM suppression, selectivity, and spurious response are relative and may be referenced using  $V_S$  or  $V_L$ . To summarize, the generator displays the voltage at the input of the DUT. Input impedance for the Si4831/35/36/20/24/25 FM tuner is high, so to convert the value displayed on the signal generator to EMF, double the voltage (add 6 dB).

**\*Note:** EMF = Electro Motive Force

## 3. FM Testing Procedure

### 3.1. FM Tuning Frequency Range

#### 3.1.1. Description

The test checks the lowest possible tuning frequency and the highest possible tuning frequency of Si4831/35/36/20/24/25 FM receiver.

#### 3.1.2. Conditions/Procedure

1. Connect test equipment as shown in Figure 1.
2. Configure the tuner in standard configuration.
3. Configure the audio analyzer:
  - a. Select Analyze.
  - b. Set Function = THD+N/SINAD.
    - i. Set Measurement Mode = SINAD.
    - ii. Set Unit = dB.
    - iii. Set Filter = A-weighting.
    - iv. Set Frequency Limit Low = 300 Hz.
    - v. Set Frequency Limit High = 15000 Hz.
4. Configure generator:
  - a. Set RF level = 0 dB $\mu$ V.
  - b. Select FM Modulation.
    - i. Set FM Deviation = 22.5 kHz.
    - ii. Set source = LFGEN.
    - iii. Set LFGEN frequency = 1 kHz.
  - c. Enable modulation.
  - d. Enable carrier.
5. Slide band switch to select FM1 band for testing.
6. Turn tuning wheel to the lowest possible position.
7. Adjust signal generator RF (by 10 kHz step), until the measured SINAD reaches maximum level. Record this RF frequency as the lowest tuning frequency  $F_{min}$ .
8. Repeat for highest tuning frequency point  $F_{max}$ .
9. Repeat for other FM band testing.

#### 3.1.3. Pass Criteria

The FM tuning frequency range should be the FM band frequency range. Refer to the Si4831/35/36/20/24/25 DEMO Board User's Guide.

## 3.2. FM Sensitivity

### 3.2.1. Description

Determine input level in dB $\mu$ Vemf to result in 26 dB SINAD in mono RX mode.

### 3.2.2. Conditions/Procedure

1. Connect test equipment as shown in Figure 1.
2. Configure the tuner in standard configuration.
3. Configure the audio analyzer:
  - a. Select Analyze.
  - b. Set Function = THD+N/SINAD.
    - i. Set Measurement Mode = SINAD.
    - ii. Set Unit = dB.
    - iii. Set Filter = A-weighting.
    - iv. Set Frequency Limit Low = 300 Hz.
    - v. Set Frequency Limit High = 15000 Hz.
4. Configure generator:
  - a. Set carrier frequency = 98 MHz.
  - b. Select FM Modulation.
    - i. Set FM Deviation = 22.5 kHz.
    - ii. Set Source = LFGEN.
    - iii. Set LFGEN frequency = 1 kHz.
  - c. Enable modulation.
  - d. Enable carrier.
5. Adjust generator RF level, VRF0, until audio analyzer SINAD = 26 dB  $\pm$ 1 dB.
6. Sensitivity (dB $\mu$ Vemf) = VRF0.

### 3.2.3. Pass Criteria

FM sensitivity should be below 10 dB $\mu$ Vemf.

### 3.3. FM Image Rejection

#### 3.3.1. Description

The test measures the FM image rejection of the tuner.

#### 3.3.2. Conditions/Procedure

1. Connect test equipment as shown in Figure 1.
2. Configure the tuner in standard configuration.
3. Configure the audio analyzer:
  - a. Select Analyze.
  - b. Set Function = THD+N/SINAD.
    - i. Set Measurement Mode = SINAD.
    - ii. Set Unit = dB.
    - iii. Set Filter = A-weighting.
    - iv. Set Frequency Limit Low = 300 Hz.
    - v. Set Frequency Limit High = 15000 Hz.
4. Configure generator:
  - a. Set carrier frequency = 98 MHz.
  - b. Select FM Modulation.
    - i. Set FM Deviation = 22.5 kHz.
    - ii. Set Source = LFGEN.
    - iii. Set LFGEN frequency = 1 kHz.
  - c. Enable modulation.
  - d. Enable carrier.
5. Adjust generator RF level, VRF1, until audio analyzer SINAD = 26 dB  $\pm$ 1 dB.
6. Record the RF level = VRF1.
7. Change generator carrier frequency to 97.744 MHz
8. Adjust generator RF level\*, VRF2, until audio analyzer SINAD = 26 dB  $\pm$ 1 dB.
9. Image rejection (dB) = VRF2 – VRF1.

**Note:** Maximum RF level setting for the R&S SML01 signal generator is 120 dB $\mu$ V. You cannot increase the RF level beyond this value. If you adjust generator RF level from VRF1 to 120 dB $\mu$ V, the audio analyzer SINAD still can not get to the SINAD = 26 dB  $\pm$ 1 dB, and your image rejection will be better than 120 dB $\mu$ V – VRF1.

#### 3.3.3. Pass Criteria

FM Image rejection should be more than 40 dB.

## 3.4. FM Selectivity –3 dB

### 3.4.1. Description

The test measures the FM frequency offset range to the tuned station when output audio level drops by 3 dB.

### 3.4.2. Conditions/Procedure

1. Connect test equipment as shown in Figure 1.
2. Configure the tuner in standard configuration.
3. Configure the audio analyzer:
  - a. Select Analyze.
  - b. Set Function = THD+N/SINAD.
    - i. Set Measurement Mode = SINAD.
    - ii. Set Unit = dB.
    - iii. Set Filter = A-weighting.
    - iv. Set Frequency Limit Low = 300 Hz.
    - v. Set Frequency Limit High = 15000 Hz.
4. Configure generator:
  - a. Set carrier frequency = 98 MHz.
  - b. Set RF level = 40 dB $\mu$ V.
  - c. Select FM Modulation.
    - i. Set FM Deviation = 22.5 kHz.
    - ii. Set Source = LFGEN.
    - iii. Set LFGEN frequency = 1 kHz.
  - d. Enable modulation.
  - e. Enable carrier.
5. Record the audio output level (dBV) = VAUDIO0.
6. Raise the signal generator RF frequency  $F_h$ , until audio output level VAUDIO1 = VAUDIO0–3.
7. Lower the signal generator RF frequency  $F_l$ , until audio output level VAUDIO1 = VAUDIO0–3.
8. Selectivity –3 dB (kHz) =  $F_h - F_l$ .

### 3.4.3. Pass Criteria

FM Selectivity for –3dB audio level difference should be between 40 kHz and 100 kHz.

## 3.5. FM Limiting –3 dB

### 3.5.1. Description

The test measures the RF input level when audio output level drops by 3 dB from the standard level.

### 3.5.2. Conditions/Procedure

1. Connect test equipment as shown in Figure 1.
2. Configure the tuner in standard configuration.
3. Configure the audio analyzer:
  - a. Select Analyze.
  - b. Set Function = THD+N/SINAD.
    - i. Set Measurement Mode = SINAD.
    - ii. Set Unit = dB.
    - iii. Set Filter = A-weighting.
    - iv. Set Frequency Limit Low = 300 Hz.
    - v. Set Frequency Limit High = 15000 Hz.
4. Configure generator:
  - a. Set carrier frequency = 98 MHz.
  - b. Set RF level = 94 dB $\mu$ V.
  - c. Select FM Modulation.
    - i. Set FM Deviation = 22.5 kHz.
    - ii. Set Source = LFGEN.
    - iii. Set LFGEN frequency = 1 kHz.
  - d. Enable modulation.
  - e. Enable carrier.
5. Record the audio output level (dBV) = VAUDIO0.
6. Adjust the signal generator RF level VRF0, until audio output level VAUDIO1 = VAUDIO0–3.
7. FM limiting –3 dB (dB $\mu$ V) = VRF0.

### 3.5.3. Pass Criteria

FM Limiting sensitivity for –3 dB audio level drop should be no more than 3 dB $\mu$ V.

## 3.6. FM Audio Frequency Response

### 3.6.1. Description

Audio frequency response is the measure of linearity of output voltage vs. modulation frequency across the audio band.

### 3.6.2. Conditions/Procedure

1. Connect test equipment as shown in Figure 1.
2. Configure the tuner in standard configuration.
3. Configure the audio analyzer:
  - a. Select Analyze.
  - b. Set Function = RMS Select.
    - i. Set Bandwidth = BP 3%.
    - ii. Set Units = dBV.
    - iii. Set Frequency Mode = FIX: 1 kHz.
4. Configure generator:
  - a. Set carrier frequency = 98 MHz.
  - b. Set RF level = 60 dB $\mu$ V.
  - c. Select Stereo Modulation.
    - i. Set FM Deviation = 10.5 kHz.
    - ii. Set L = R.
    - iii. Set Source = LFGEN.
    - iv. Set LFGEN frequency = 1 kHz.
    - v. Set Pre-emphasis = 75  $\mu$ s.
    - vi. Set Pilot = ON.
    - vii. Set Pilot Deviation = 6.75 kHz.
  - d. Enable modulation.
  - e. Enable carrier.
5. Audio 1 kHz level (dBV) = V1 kHz.
6. Configure audio analyzer frequency mode through RMS Select Function. Set Frequency Mode = FIX: 30 Hz.
7. Configure generator LFGEN frequency = 30 Hz.
8. Audio 30 Hz level (dBV) = V30 Hz.
9. Configure audio analyzer frequency mode through RMS Select Function. Set Frequency Mode = FIX: 15 kHz.
10. Configure generator LFGEN frequency = 15 kHz.
11. Audio 15 kHz level (dBV) = V15 kHz.
12. Audio frequency response (dB) equals the greater magnitude of (V30 Hz – V1 kHz) and (V15 kHz – V1 kHz).

**Note:** If you test the band with De-emphasis 50  $\mu$ s, you should Set Pre-emphasis = 50  $\mu$ s.

### 3.6.3. Pass Criteria

The greater magnitude of (V30 Hz – V1 kHz) and (V15 kHz – V1 kHz) should be no more than 3 dB.



## 3.7. FM Stereo Separation

### 3.7.1. Description

The test quantifies leakage or crosstalk from one channel to another in stereo mode.

### 3.7.2. Conditions/Procedure

1. Connect test equipment as shown in Figure 1.
2. Configure the tuner in standard configuration.
3. Configure the audio analyzer:
  - a. Select Analyze.
  - b. Set Function = RMS Select.
    - i. Set Bandwidth = BP 3%.
    - ii. Set Units = dBV.
    - iii. Set Frequency Mode = FIX: 1 kHz.
4. Configure generator:
  - a. Set carrier frequency = 98 MHz.
  - b. Set RF level = 60 dB $\mu$ V.
  - c. Select Stereo Modulation.
    - i. Set FM Deviation = 67.5 kHz.
    - ii. Set L = 1, R = 0.
    - iii. Set Source = LFGEN.
    - iv. Set LFGEN frequency = 1 kHz.
    - v. Set Pre-emphasis = 75  $\mu$ s.
    - vi. Set Pilot = ON.
    - vii. Set Pilot Deviation = 6.75 kHz.
  - d. Enable modulation.
  - e. Enable carrier.
5. Left channel audio level (dBV) = VAUDIOL1.
6. Right channel audio level (dBV) = VAUDIOR1.
7. Record the Audio Stereo Separation1 (dB) = abs (VAUDIOL1 – VAUDIOR1).
8. Configure generator:
  - a. Set carrier frequency = 98 MHz.
  - b. Set RF level = 60 dB $\mu$ V.
  - c. Select Stereo Modulation.
    - i. Set FM Deviation = 67.5 kHz.
    - ii. Set L = 0, R = 1.
    - iii. Set Source = LFGEN.
    - iv. Set LFGEN frequency = 1 kHz.
    - v. Set Pre-emphasis = 75  $\mu$ s.
    - vi. Set Pilot = ON.
    - vii. Set Pilot Deviation = 6.75 kHz.
  - d. Enable modulation.
  - e. Enable carrier.
9. Left channel audio level (dBV) = VAUDIOL2.
10. Right channel audio level (dBV) = VAUDIOR2.

11. Record the Audio Stereo Separation<sub>2</sub> (dB) =  $\text{abs}(\text{VAUDIOL}_2 - \text{VAUDIOR}_2)$ .
12. Audio Stereo Separation (dB) =  $\text{minimum}(\text{Audio Stereo Separation}_1, \text{Audio Stereo Separation}_2)$

### 3.7.3. Pass Criteria

FM Stereo separation should be greater than 32 dB.

## 3.8. FM Audio L/R Imbalance

### 3.8.1. Description

The test measures the gain/level imbalance between L and R channels in stereo mode.

### 3.8.2. Conditions/Procedure

1. Connect test equipment as shown in Figure 1.
2. Configure the tuner in standard configuration.
3. Configure the audio analyzer:
  - a. Select Analyze.
  - b. Set Function = RMS Select.
    - i. Set Bandwidth = BP 3%.
    - ii. Set Units = dBV.
    - iii. Set Frequency Mode = FIX: 1 kHz.
4. Configure generator:
  - a. Set carrier frequency = 98 MHz.
  - b. Set RF level = 60 dB $\mu$ V.
  - c. Select FM Modulation.
    - i. Set FM Deviation = 75 kHz.
    - ii. Set RF level = 60 dB $\mu$ V.
    - iii. Set Source = LFGEN.
    - iv. Set LFGEN frequency = 1 kHz.
  - d. Enable modulation.
  - e. Enable carrier.
5. Left channel audio level (dBV) = VAUDIOL.
6. Right channel audio level (dBV) = VAUDIOR.
7. Audio L/R imbalance (dB) =  $\text{abs}(\text{VAUDIOL} - \text{VAUDIOR})$ .

### 3.8.3. Pass Criteria

FM audio L/R imbalance should be no more than 1 dB.

### 3.9. FM Tuning Indicator Sensitivity

#### 3.9.1. Description

The test measures the needed RF input level to turn on the tuning indicator.

#### 3.9.2. Conditions/Procedure

1. Connect test equipment as shown in Figure 1.
2. Configure the tuner in standard configuration.
3. Configure the audio analyzer:
  - a. Select Analyze.
  - b. Set Function = THD+N/SINAD.
    - i. Set Measurement Mode = SINAD.
    - ii. Set Unit = dB.
    - iii. Set Filter = A-weighting.
    - iv. Set Frequency Limit Low = 300 Hz.
    - v. Set Frequency Limit High = 15000 Hz.
4. Configure generator:
  - a. Set carrier frequency = 98 MHz.
  - b. Set RF level = 60 dB $\mu$ V.
  - c. Select FM Modulation.
    - i. Set FM Deviation = 22.5 kHz.
    - ii. Set source = LFGEN.
    - iii. Set LFGEN frequency = 1 kHz.
  - d. Enable modulation.
  - e. Enable carrier.
5. Decrease signal generator RF level until the tuning indicator turns off.
6. Increase signal generator RF level VRF0 from low to high until tuning indicator turns on.
7. FM tuning indicator sensitivity = VRF0.

#### 3.9.3. Pass Criteria

FM tuning indicator sensitivity should be no more than 15 dB $\mu$ V.

## 3.10. FM Stereo Indicator Sensitivity

### 3.10.1. Description

The test measures the needed RF input level to turn on the stereo indicator.

### 3.10.2. Conditions/Procedure

1. Connect test equipment as shown in Figure 1.
2. Configure the tuner in standard configuration.
3. Configure the audio analyzer:
  - a. Select Analyze.
  - b. Set Function = THD+N/SINAD.
    - i. Set Measurement Mode = SINAD.
    - ii. Set Unit = dB.
    - iii. Set Filter = A-weighting.
    - iv. Set Frequency Limit Low = 300 Hz.
    - v. Set Frequency Limit High = 15000 Hz.
4. Configure generator:
  - a. Set carrier frequency = 98 MHz.
  - b. Set RF level = 60 dB $\mu$ V.
  - c. Select Stereo Modulation.
    - i. Set FM Deviation = 22.5 kHz.
    - ii. Set L = 1, R = 1.
    - iii. Set Source = LFGEN.
    - iv. Set LFGEN frequency = 1 kHz.
    - v. Set Pre-emphasis = 75  $\mu$ s.
    - vi. Set Pilot = ON.
    - vii. .Set Pilot Deviation = 6.75 kHz.
  - d. Enable modulation.
  - e. Enable carrier.
5. Decrease signal generator RF level until the tuning indicator turns off.
6. Increase signal generator RF level VRF0 from low to high until stereo indicator turns on.
7. FM stereo indicator sensitivity = VRF0.

### 3.10.3. Pass Criteria

FM stereo indicator sensitivity should be 18~22 dB $\mu$ V for bands with an FM stereo indicator threshold of 6 dB separation at 20 dB $\mu$ V RF input.

FM stereo indicator sensitivity should be 26~30 dB $\mu$ V for bands with an FM stereo indicator threshold of 12 dB separation at 28 dB $\mu$ V RF input.

### 3.11. FM Mono Distortion

#### 3.11.1. Description

The test measures THD in FM Mono mode with a fixed, moderate input signal strength.

#### 3.11.2. Conditions/Procedure

1. Connect test equipment as shown in Figure 1.
2. Configure the tuner in standard configuration.
3. Configure the audio analyzer:
  - a. Select Analyze.
  - b. Set Function = THD.
    - i. Set Measurement Mode = All di (all harmonics).
    - ii. Select Unit = %.
4. 4. Configure generator:
  - a. Set carrier frequency = 98 MHz.
  - b. Select FM Modulation.
    - i. Set FM Deviation = 75 kHz.
    - ii. Set RF level = 60 dB $\mu$ V.
    - iii. Set source = LFGEN.
    - iv. Set LFGEN frequency = 1 kHz.
  - c. Enable modulation.
  - d. Enable carrier.
5. Adjust volume control wheel to get audio output level RMS = -20 dBV.
6. Record THD (%).

#### 3.11.3. Pass Criteria

FM Mono distortion should be no more than 0.5%.

## 3.12. FM Mono SNR

### 3.12.1. Description

The test measures Signal to Noise ratio in FM mono mode at a fixed, moderate input signal strength.

### 3.12.2. Conditions/Procedure

1. Connect test equipment as shown in Figure 1.
2. Configure the tuner in standard configuration.
3. Configure the audio analyzer:
  - a. Select Analyze.
  - b. Set Function = THD+N/SINAD.
    - i. Set Measurement Mode = Noise.
    - ii. Set Unit = dB.
    - iii. Set Filter = A-weighting.
    - iv. Set Frequency Limit Low = 300 Hz.
    - v. Set Frequency Limit High = 15000 Hz.
4. Configure generator:
  - a. Set carrier frequency = 98 MHz.
  - b. Set RF level = 60 dB $\mu$ V.
  - c. Select FM Modulation.
    - i. Set FM Deviation = 22.5 kHz.
    - ii. Set Source = LFGEN.
    - iii. Set LFGEN frequency = 1 kHz.
  - d. Enable modulation.
  - e. Enable carrier.
5. Record SNR (dB) = Noise (dB).

### 3.12.3. Pass Criteria

FM SNR should be more than 55 dB.

### 3.13. FM Radio AM Suppression

#### 3.13.1. Description

The test quantifies AM suppression by measuring the difference at the audio output between FM and AM modulated input signals.

#### 3.13.2. Conditions/Procedure

1. Connect test equipment as shown in Figure 1.
2. Configure the tuner in standard configuration.
3. Configure the audio analyzer:
  - a. Select Analyze.
  - b. Set Function = RMS Select.
    - i. Set Bandwidth = BP 3%.
    - ii. Set Units = dBV.
    - iii. Set Frequency Mode = FIX: 1 kHz.
4. Configure generator:
  - a. Set carrier frequency = 98 MHz.
  - b. Set RF level = 60 dB $\mu$ V.
  - c. Select FM Modulation.
    - i. Set FM Deviation = 22.5 kHz.
    - ii. Set Source = LFGEN.
    - iii. Set LFGEN frequency = 1 kHz.
  - d. Enable modulation.
  - e. Enable carrier.
5. Record the audio level, VAUDIO0.
6. Turn off generator FM modulation.
7. Configure generator:
  - a. Set carrier frequency = 98 MHz.
  - b. Set RF level = 60 dB $\mu$ V.
  - c. Select AM Modulation.
    - i. Set Depth = 30%.
    - ii. Set Source = LFGEN.
    - iii. Set LFGEN frequency = 1 kHz.
  - d. Enable modulation.
  - e. Enable carrier.
8. Record the audio level, VAUDIO1.
9. AM Suppression (dB) = VAUDIO0 – VAUDIO1.

#### 3.13.3. Pass Criteria:

FM radio AM suppression should be more than 40 dB.

## 3.14. FM Audio Output Voltage

### 3.14.1. Description

The test measures FM Audio Volume Level at an RF Level of 60 dB $\mu$ Vemf.

### 3.14.2. Conditions/Procedure

1. Connect test equipment as shown in Figure 1.
2. Configure the tuner in standard configuration.
3. Configure the audio analyzer:
  - a. Select Analyze.
  - b. Set Function = THD+N/SINAD.
    - i. Set Measurement Mode = SINAD.
    - ii. Set Unit = dB.
    - iii. Set Filter = A-weighting.
    - iv. Set Frequency Limit Low = 300 Hz.
    - v. Set Frequency Limit High = 15000 Hz.
4. Configure generator:
  - a. Set carrier frequency = 98 MHz.
  - b. Set RF level = 60 dB $\mu$ V.
  - c. Select FM Modulation.
    - i. Set FM Deviation = 22.5 kHz.
    - ii. Set source = LFGEN.
    - iii. Set LFGEN frequency = 1 kHz.
  - d. Enable modulation.
  - e. Enable carrier.
5. Test the audio voltage at FM tuner audio output pin Lout or Rout.

### 3.14.3. Pass Criteria

FM audio output voltage level should range from 72 to 90 mVrms.



### 3.15. FM Adjacent Channel Selectivity ( $\pm 200$ kHz)

#### 3.15.1. Description

The test quantifies receiver vulnerability to adjacent-channel signals at offset  $\pm 200$  kHz from desired signal. This is a data sheet specification; two signal generators and one power combiner are used in the test.

#### 3.15.2. Conditions/Procedure

1. Connect test equipment as shown in Figure 2.
2. Configure the tuner in standard configuration.
3. Configure the audio analyzer:
  - a. Select Analyze.
  - b. Set Function = RMS Select.
    - i. Set Bandwidth = BP 3%.
    - ii. Set Units = dBV.
    - iii. Set Frequency Mode = FIX: 1 kHz.
4. Configure generator #1:
  - a. Set carrier frequency = 98 MHz.
  - b. Set RF level VRF0 = 40 dB $\mu$ V.
  - c. Select FM Modulation.
    - i. Set FM Deviation = 22.5 kHz.
    - ii. Set source = LFGEN.
    - iii. Set LFGEN frequency = 1 kHz.
  - d. Enable modulation.
  - e. Enable carrier.
5. Record the audio level, VAUDIO0.
6. Disable generator modulation.
7. Configure generator #2:
  - a. Set carrier frequency = 98.2 MHz.
  - b. Set RF level = 60 dB $\mu$ V.
  - c. Select FM Modulation.
    - i. Set FM Deviation = 22.5 kHz.
    - ii. Set source = LFGEN.
    - iii. Set LFGEN frequency = 1 kHz.
  - d. Enable modulation.
  - e. Enable carrier.
8. Adjust generator #2 RF level\*, VRF1, until the audio level, VAUDIO1 = VAUDIO0 – 30 dB.
9. Selectivity Adjacent Channel +200k (dB) = VRF1 – VRF0.
10. Configure generator #2:
  - a. Set carrier frequency = 97.8 MHz.
  - b. Set RF level = 60 dB $\mu$ V.
  - c. Select FM Modulation.
    - i. Set FM Deviation = 22.5 kHz.
    - ii. Set source = LFGEN.
    - iii. Set LFGEN frequency = 1 kHz.

d. Enable modulation.

e. Enable carrier.

11. Adjust generator #2 RF level\*, VRF2, until the audio level, VAUDIO1 = VAUDIO0 – 30 dB.

12. Selectivity Adjacent Channel –200 k (dB) = VRF2 – VRF0.

13. Selectivity Adjacent Channel  $\pm 200$  k = minimum (VRF1 – VRF0, VRF2 – VRF0).

**\*Note:** Generator #1 RF level is set to 40 dB $\mu$ V to be able to get selectivity results greater than 60 dB. This is not a limitation of the FM tuner or the evaluation board. Maximum RF level setting for the R&S SML01 signal generator is 120 dB $\mu$ V. You cannot increase the RF level beyond this value, so if VRF0 = 60 dB $\mu$ V, selectivity numbers would be limited to 60 dB.

### 3.15.3. Pass Criteria

FM adjacent channel selectivity should be more than 50 dB.

## 3.16. FM Alternate Channel Selectivity ( $\pm 400$ kHz)

### 3.16.1. Description

The test quantifies receiver vulnerability to alternate-channel signals at offset  $\pm 400$  kHz from desired signal. This is a data sheet specification; two signal generators and one power combiner are used in the test.

### 3.16.2. Conditions/Procedure

1. Connect test equipment as shown in Figure 2.
2. Configure the tuner in standard configuration.
3. Configure the audio analyzer:
  - a. Select Analyze.
  - b. Set Function = RMS Select.
    - i. Set Bandwidth = BP 3%.
    - ii. Set Units = dBV.
    - iii. Set Frequency Mode = FIX: 1 kHz.
4. Configure generator #1:
  - a. Set carrier frequency = 98 MHz.
  - b. Set RF level VRF0 = 40 dB $\mu$ V.
  - c. Select FM Modulation.
    - i. Set FM Deviation = 22.5 kHz.
    - ii. Set source = LFGEN.
    - iii. Set LFGEN frequency = 1 kHz.
  - d. Enable modulation.
  - e. Enable carrier.
5. Record the audio level, VAUDIO0.
6. Disable generator modulation.
7. Configure generator #2:
  - a. Set carrier frequency = 98.4 MHz (Alternate Channel +400 k).
  - b. Set RF level = 60 dB $\mu$ V.
  - c. Select FM Modulation.
    - i. Set FM Deviation = 22.5 kHz.
    - ii. Set source = LFGEN.
    - iii. Set LFGEN frequency = 1 kHz.
  - d. Enable modulation.
  - e. Enable carrier.

8. Adjust generator #2 RF level\*, VRF1, until the audio level, VAUDIO1 = VAUDIO0 – 30 dB.
9. Selectivity Alternate Channel +400 k (dB) = VRF1 – VRF0.
10. Configure generator #2:
  - a. Set carrier frequency = 97.6 MHz (Alternate Channel –400 k).
  - b. Set RF level = 60 dB $\mu$ V.
  - c. Select FM Modulation.
    - i. Set FM Deviation = 22.5 kHz.
    - ii. Set source = LFGEN.
    - iii. Set LFGEN frequency = 1 kHz.
  - d. Enable modulation.
  - e. Enable carrier.
11. Adjust generator #2 RF level\*, VRF2, until the audio level, VAUDIO1 = VAUDIO0 – 30 dB.
12. Selectivity Alternate Channel –400 k (dB) = VRF2 – VRF0.
13. Selectivity Alternate Channel  $\pm$ 400 k = minimum (VRF1 – VRF0, VRF2 – VRF0).

**\*Note:** Generator #1 RF level is set to 40 dB $\mu$ V to be able to get selectivity results greater than 60 dB. This is not a limitation of the FM tuner or the evaluation board. Maximum RF level setting for the R&S SML01 signal generator is 120 dB $\mu$ V. You cannot increase the RF level beyond this value, so if VRF0 = 60 dB $\mu$ V, selectivity numbers would be limited to 60 dB.

### 3.16.3. Pass Criteria

FM alternate channel selectivity should be more than 60 dB.

## 3.17. FM Stereo Pilot Rejection

### 3.17.1. Description

Stereo pilot rejection is the quality criterion of a tuner that is measured as the ratio of wanted audio frequency voltage to pilot frequency voltage according to the equation:

$$\text{Pilot Rejection} = V_{\text{audio0}}(1 \text{ kHz}) + 20 \cdot \log(\Delta_{\text{pilot}}/\Delta f) - V_{\text{audio0}}(19 \text{ kHz})$$

where  $\Delta f$  is FM frequency deviation and  $\Delta_{\text{pilot}}$  is pilot frequency deviation.

### 3.17.2. Conditions/Procedure

1. Connect test equipment as shown in Figure 1.
2. Configure the tuner in standard configuration.
3. Configure the audio analyzer:
  - a. Select Analyze.
  - b. Set Function = RMS Select.
    - i. Set Bandwidth = BP 3%.
    - ii. Set Units = dBV.
    - iii. Set Frequency Mode = FIX: 1 kHz.
4. Configure generator:
  - a. Set carrier frequency = 98 MHz.
  - b. Set RF level = 60 dB $\mu$ V.
  - c. Select Stereo Modulation.
    - i. Set FM Deviation = 67.5 kHz.
    - ii. Set L = 1, R = 1.
    - iii. Set Source = LFGEN.
    - iv. Set LFGEN frequency = 1 kHz.
    - v. Set Pre-emphasis = 75  $\mu$ s.
    - vi. Set Pilot = ON.
    - vii. Set Pilot Deviation = 6.75 kHz.
  - d. Enable modulation.
  - e. Enable carrier.
5. Adjust volume control wheel to get audio output level RMS = -20 dBV.
6. Audio 1 kHz level (dBV) = V1 kHz.
7. Disable 1 kHz tone (by disabling 1 kHz source, not stereo mod).
8. Configure audio analyzer frequency mode = FIX: 19 kHz.
9. Audio 19 kHz level (dBV) = V19kHz.
10. Pilot Rejection (relative to pilot) (dB) = V1kHz - V19 kHz + 20\*log<sub>10</sub> ( $\Delta_{\text{pilot}}/\Delta f$ ) = V1kHz - V19 kHz - 20.

### 3.17.3. Pass Criteria

FM Stereo pilot rejection should be more than 40 dB.

## 4. AM/SW Tuner Testing Setup

### 4.1. AM/SW Common Setup

#### AM tuner standard configuration.

- Tune tuner exactly to AM frequency = 1000 kHz. See the Si4831/35/36/20/24/25 DEMO Board User's Guide for details.
- RF Level at the antenna input 74 dB $\mu$ Vemf.
- Set volume to maximum unless otherwise specified.
- Ensure cable length between the generator and antenna input is as short as possible.

#### SW tuner standard configuration.

- Tune tuner exactly to SW frequency = 11.85 MHz. See Si4835/36/24/25 DEMO Board User's Guide for details.
- RF Level at the antenna input 74 dB $\mu$ Vemf.
- Set volume to maximum unless otherwise specified.
- Connect SG to the antenna input through an antenna dummy (10 pF cap in series); cable length between the generator and antenna input should be as short as possible.

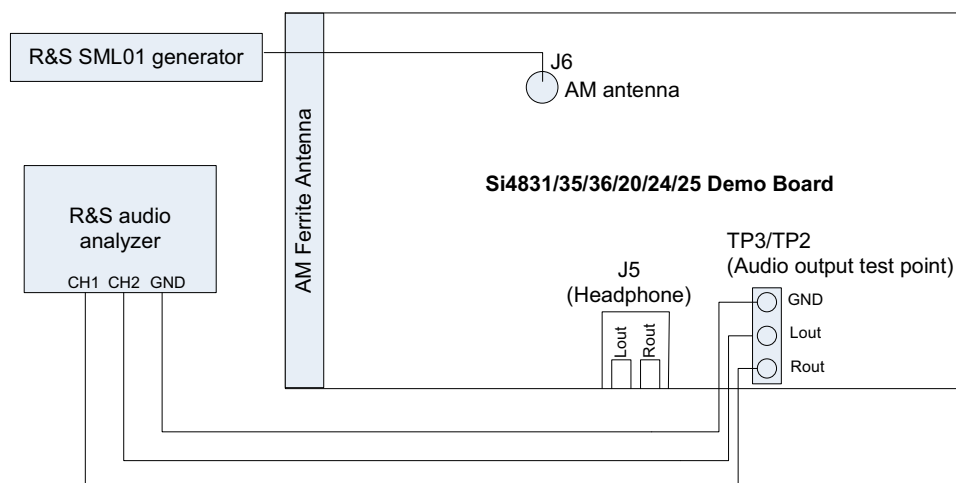
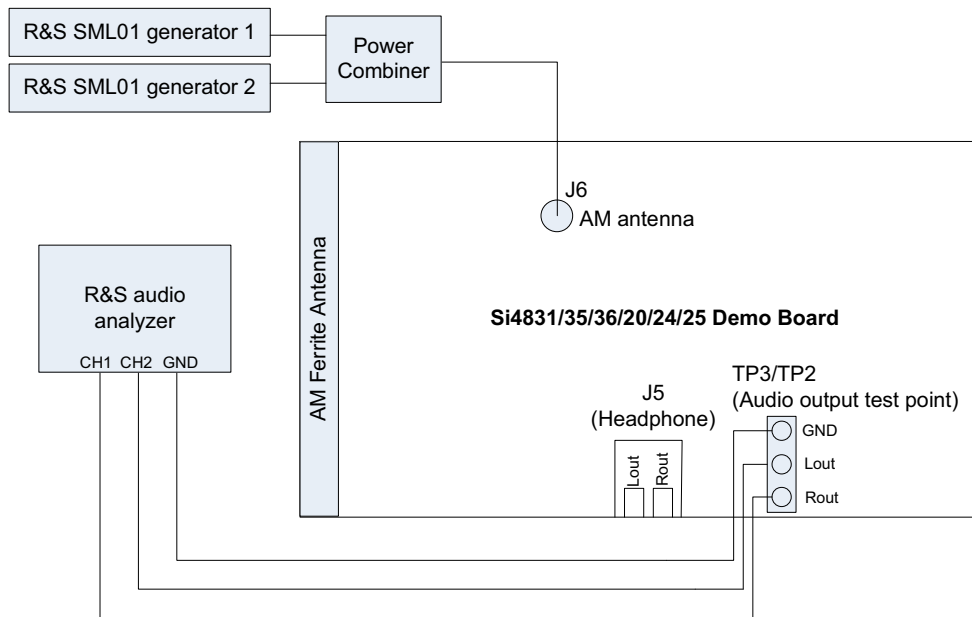
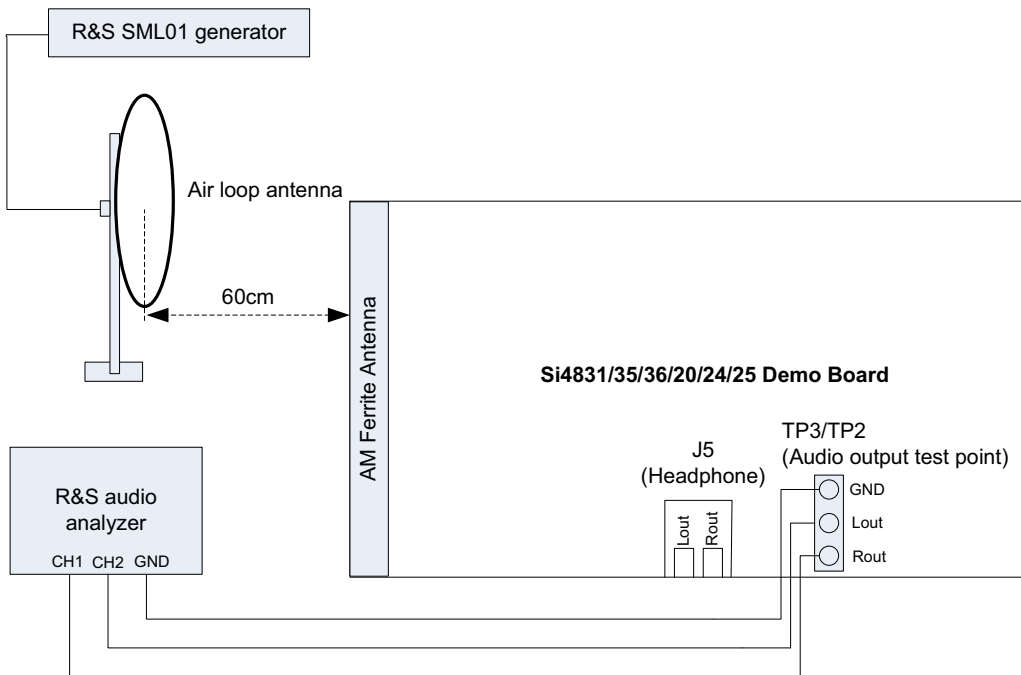

Figure 3. AM Tuner Setup with One Generator



**Figure 4. AM Tuner Setup with Two Generators**



**Figure 5. AM Tuner Radiation Test Setup**

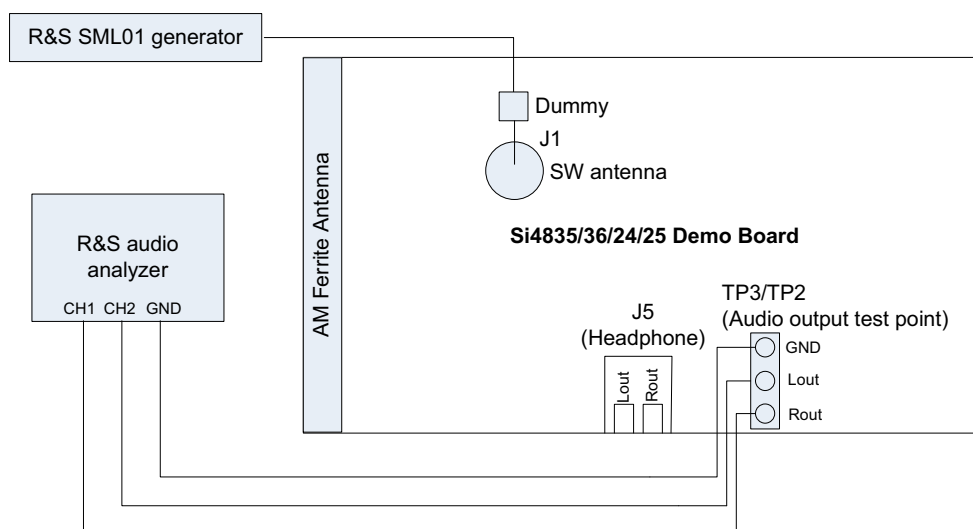

**Figure 6. SW Tuner Setup with One Generator**

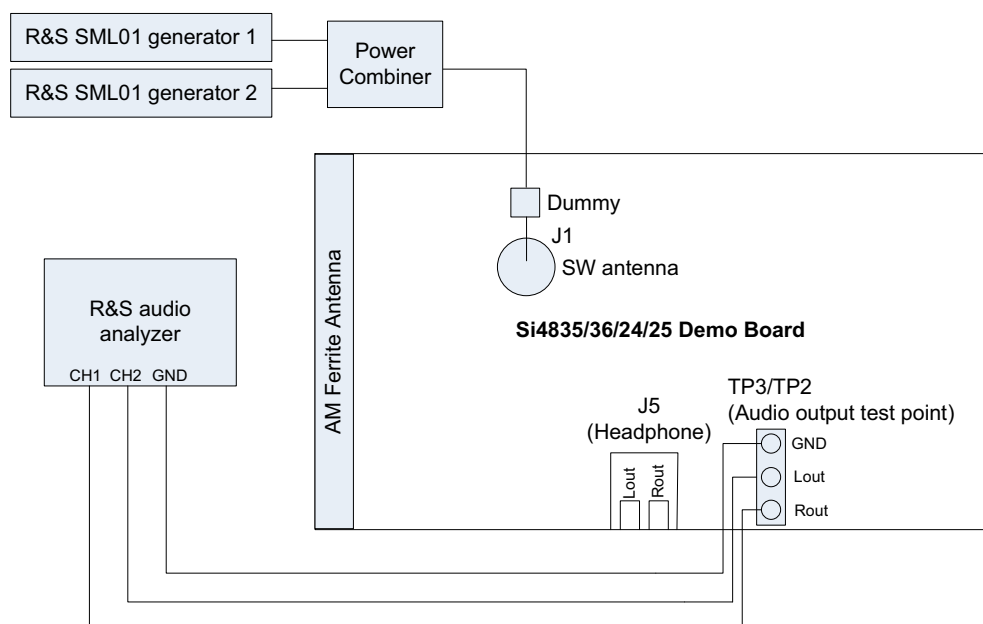

**Figure 7. SW Tuner Setup with Two Generators**

**AM/SW tuner test equipment lists:**

- Rohde & Schwarz UPL Audio Analyzer
- Rohde & Schwarz SML01 Signal Generator
- Mini-Circuits Power Combiner
- SW Antenna Dummy

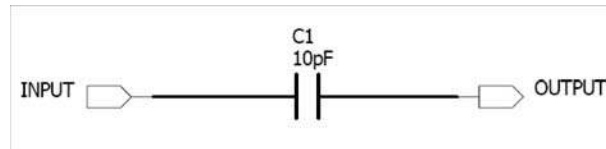

**Figure 8. SW Antenna Dummy Circuit**

## 4.2. AM/SW Tuner Testing Considerations

Several issues must be considered to make accurate measurements.

First, the power combiner and cable losses must be calibrated and factored into each measurement. The loss for the Mini-Circuit power combiner is approximately 6 dB.

Second, most signal generators display the voltage generated at the input of the device under test (DUT) assuming an input resistance of 50  $\Omega$ . For example, if the signal generator displays  $V_L = 1 \mu\text{V}$  (0 dB $\mu\text{V}$ ), the generator source voltage  $V_S$  is 2  $\mu\text{V}$  (6 dB $\mu\text{V}$ ). The load voltage  $V_L$  is generated from the source voltage  $V_S$  by the voltage divider created by the 50  $\Omega$  generator source resistance  $R_S$  and the 50  $\Omega$  load resistance  $R_L$ . This distinction is important only for sensitivity, which is specified in  $\mu\text{V EMF}^*$ , where EMF refers to the source voltage  $V_S$ . Measurements such as AM suppression, selectivity, and spurious response are relative and may be referenced using  $V_S$  or  $V_L$ . To summarize, the generator displays the voltage at the input of the DUT. Input impedance for the Si4831/35/36/20/24/25 tuner is high, so to convert the value displayed on the signal generator to EMF, double the voltage (add 6 dB).

For SW testing, connect the SG to the antenna input through an antenna dummy to simulate the characteristics of normal whip antenna at SW frequency band.



## 5. AM/SW Testing Procedure

### 5.1. AM/SW Tuning Frequency Range

#### 5.1.1. Description

The test checks the lowest possible tuning frequency and the highest possible tuning frequency of a selected band of Si4831/35/36/20/24/25 AM/SW receiver.

#### 5.1.2. Conditions/Procedure

1. Connect test equipment as shown in Figure 3 or Figure 6.
2. Configure the tuner in standard configuration.
3. Configure the audio analyzer:
  - a. Select Analyze.
  - b. Set Function = THD+N/SINAD.
    - i. Set Measurement Mode = SINAD.
    - ii. Set Unit = dB.
    - iii. Set Filter = A-weighting.
    - iv. Set Frequency Limit Low = 300 Hz.
    - v. v. Set Frequency Limit High = 15000 Hz.
4. Configure generator:
  - a. Select AM Modulation.
    - i. Set AM Modulation Depth = 30%.
    - ii. Set Source = LFGEN.
    - iii. Set LFGEN frequency = 1 kHz.
    - iv. Set RF level = 20 dB $\mu$ V.
  - b. Enable AM modulation.
  - c. Enable RF carrier.
5. Slide band switch to select AM1/SW1 band for testing.
6. Turn tuning wheel to the lowest possible position.
7. Adjust signal generator RF (by 10 kHz step), until the measured SINAD reaches maximum level. Record this RF frequency as the lowest tuning frequency  $F_{min}$ .
8. Repeat for highest tuning frequency point  $F_{max}$ .
9. Repeat for other AM/SW band testing.

#### 5.1.3. Pass Criteria

The AM/SW tuning frequency range should be the AM/SW band frequency range, refer to the Si4831/35/36/20/24/25 DEMO Board User's Guide.

## 5.2. AM/SW Sensitivity

### 5.2.1. Description

Sensitivity is the RF level in dB $\mu$ Vemf at the input of the antenna at which audio SINAD equals 26dB.

### 5.2.2. Conditions/Procedure

1. Connect test equipment as shown in Figures 3 or 6.
2. Configure the tuner in standard configuration.
3. Configure the audio analyzer:
  - a. Select Analyze.
  - b. Set Function = THD+N/SINAD.
    - i. Set Measurement Mode = SINAD.
    - ii. Set Unit = dB.
    - iii. Set Filter = A-weighting.
    - iv. Set Frequency Limit Low = 300 Hz.
    - v. Set Frequency Limit High = 15000 Hz.
4. Configure generator:
  - a. Set carrier frequency = 1000 kHz (11.85 MHz for shortwave).
  - b. Select AM Modulation.
    - i. Set AM Modulation Depth = 30%.
    - ii. Set source = LFGEN.
    - iii. Set LFGEN frequency = 1 kHz.
  - c. Enable AM modulation.
  - d. Enable RF carrier.
5. Adjust generator RF level, VRF0, until audio analyzer SINAD = 26 dB  $\pm$  1 dB.
6. Sensitivity (dB $\mu$ V) = VRF0.

### 5.2.3. Pass Criteria

AM/SW sensitivity should be no more than 33 dB $\mu$ Vemf.

## 5.3. AM Sensitivity—Radiation

### 5.3.1. Description

Sensitivity is the RF level in dB $\mu$ Vemf at the input of the standard AM loop antenna connected to signal generator, when the Demo board output Audio SINAD equals 26 dB.

### 5.3.2. Conditions/Procedure

1. Connect test equipment as shown in Figure 5.
2. Configure the tuner in standard configuration; this test must be conducted inside a shielded room.
3. Configure the audio analyzer:
  - a. Select Analyze.
  - b. Set Function = THD+N/SINAD.
    - i. Set Measurement Mode = SINAD.
    - ii. Set Unit = dB.
    - iii. Set Filter = A-weighting.
    - iv. Set Frequency Limit Low = 300 Hz.
    - v. Set Frequency Limit High = 15000 Hz.
4. Configure generator:
  - a. Set carrier frequency = 1000 kHz.
  - b. Select AM Modulation.
    - i. Set AM Modulation Depth = 30%.
    - ii. Set source = LFGEN.
    - iii. Set LFGEN frequency = 1 kHz.
  - c. Enable AM modulation.
  - d. Enable RF carrier.
5. Adjust generator RF level, VRF0, until audio analyzer SINAD = 26 dB  $\pm$ 1 dB.
6. Sensitivity (dB $\mu$ V) = VRF0.

**Note:** TX antenna is the standard AM loop antenna; Rx antenna is the ferrite loop stick antenna mounted on the Si4831/35/36/20/24/25 DEMO board or air loop antenna that can be connected to the demo board. Distance between Tx antenna and Rx antenna is 60 cm, center to center.

### 5.3.3. Pass Criteria

AM radiation sensitivity should be no more than 78 dB $\mu$ Vemf.

## 5.4. AM/SW Image Rejection

### 5.4.1. Description

The test measures the AM/SW image rejection of the tuner.

### 5.4.2. Conditions/Procedure

1. Connect test equipment as shown in Figure 3 or Figure 6.
2. Configure the tuner in standard configuration.
3. Configure the audio analyzer:
  - a. Select Analyze.
  - b. Set Function = THD+N/SINAD.
    - i. Set Measurement Mode = SINAD.
    - ii. Set Unit = dB.
    - iii. Set Filter = A-weighting.
    - iv. Set Frequency Limit Low = 300 Hz.
    - v. Set Frequency Limit High = 15000 Hz.
4. Configure generator:
  - a. Set carrier frequency = 1000 kHz (11.85 MHz for shortwave).
  - b. Select AM Modulation.
    - i. Set AM Modulation Depth = 30%.
    - ii. Set source = LFGEN.
    - iii. Set LFGEN frequency = 1 kHz.
  - c. Enable AM modulation.
  - d. Enable RF carrier.
5. Adjust generator RF level, VRF1, until audio analyzer SINAD = 26 dB  $\pm$ 1 dB.
6. Record the RF level = VRF1.
7. Change generator carrier frequency to 1090 kHz (11.76 MHz for shortwave).
8. Adjust generator RF level\*, VRF2, until audio analyzer SINAD = 26 dB  $\pm$ 1 dB.
9. Record the RF level = VRF2.
10. Image rejection (dB) = VRF2 – VRF1.

**\*Note:** Maximum RF level setting for the R&S SML01 signal generator is 120 dB $\mu$ V. You cannot increase the RF level beyond this value. So if you adjust generator RF level from VRF1 to 120 dB $\mu$ V, the audio analyzer SINAD still can not get to the SINAD = 26 dB  $\pm$ 1 dB, and your image rejection will be better than 120 dB $\mu$ V – VRF1.

### 5.4.3. Pass Criteria

AM/SW Image rejection should be no less than 60 dB.

## 5.5. AM/SW Selectivity –6 dB

### 5.5.1. Description

The test measures the AM/SW frequency range when audio output level drops by 6 dB.

### 5.5.2. Conditions/Procedure

1. Connect test equipment as shown in Figure 3 or Figure 6.
2. Configure the tuner in standard configuration.
3. Configure the audio analyzer:
  - a. Select Analyze.
  - b. Set Function = THD+N/SINAD.
    - i. Set Measurement Mode = SINAD.
    - ii. Set Unit = dB.
    - iii. Set Filter = A-weighting.
    - iv. Set Frequency Limit Low = 300 Hz.
    - v. Set Frequency Limit High = 15000 Hz.
4. Configure generator:
  - a. Set carrier frequency = 1000 kHz (11.85 MHz for shortwave).
  - b. Select AM Modulation.
    - i. Set AM Modulation Depth = 30%.
    - ii. Set source = LFGEN.
    - iii. Set LFGEN frequency = 1 kHz.
  - c. Enable AM modulation.
  - d. Enable RF carrier.
5. Adjust generator RF level VRF1, until audio analyzer SINAD = 26 dB  $\pm$  1 dB
6. Record the audio output level (dBV) = VAUDIO0
7. Raise the signal generator RF frequency Fh, until audio output level VAUDIO1 = VAUDIO0-6.
8. Lower the signal generator RF frequency Fl, until audio output level VAUDIO1 = VAUDIO0-6.
9. Selectivity –6dB (kHz) = Fh – Fl.

### 5.5.3. Pass Criteria

AM/SW selectivity –6dB should be no more than 35 kHz.

## 5.6. AM/SW Adjacent Channel Selectivity

### 5.6.1. Description

The test measures AM/SW receiver susceptibility to blockers at adjacent channel ( $\pm 10$  kHz or  $\pm 9$  kHz). Two signal generators and one power combiner are used in the test.

### 5.6.2. Conditions/Procedure

1. Connect test equipment as shown in Figure 4 or Figure 7.
2. Configure the tuner in standard configuration.
3. Configure the audio analyzer:
  - a. Select Analyze.
  - b. Set Function = RMS Select.
    - i. Set Bandwidth = BP 3%.
    - ii. Set Units = dBV.
    - iii. Set Frequency Mode = FIX: 1 kHz.
4. Configure generator #1:
  - a. Set carrier frequency = 1000 kHz (11.85 MHz for shortwave).
  - b. Set RF level VRF0 = 40 dB $\mu$ V.<sup>1</sup>
  - c. Select AM Modulation.
    - i. Set AM Modulation Depth = 30%.
    - ii. Set source = LFGEN.
    - iii. Set LFGEN frequency = 1 kHz.
  - d. Enable AM modulation.
  - e. Enable RF carrier.
5. Record the audio level, VAUDIO0.
6. Disable generator modulation.
7. Configure generator #2:
  - a. Set carrier frequency = 1010 kHz (Adjacent Channel +10 k).<sup>2,3,4</sup>
  - b. Set RF level = 50 dB $\mu$ V.
  - c. Select AM Modulation.
    - i. Set AM Modulation Depth = 30%.
    - ii. Set source = LFGEN.
    - iii. Set LFGEN frequency = 1 kHz.
  - d. Enable AM modulation.
  - e. Enable RF carrier.
8. Adjust generator #2 RF level\*, VRF1, until the audio level, VAUDIO1 = VAUDIO0 – 30 dB.
9. Selectivity Adjacent Channel +10k (dB) = VRF1 – VRF0.
10. Configure generator #2:
  - a. Set carrier frequency = 990 kHz (Adjacent Channel –10 k).<sup>2,3,4</sup>
  - b. Set RF level = 50 dB $\mu$ V.
  - c. Select AM Modulation.
    - i. Set AM Modulation Depth = 30%.
    - ii. Set source = LFGEN.
    - iii. Set LFGEN frequency = 1 kHz.

- d. Enable AM modulation.
- e. Enable RF carrier.
11. Adjust generator #2 RF level\*, VRF2, until the audio level, VAUDIO1 = VAUDIO0 – 30 dB.
12. Selectivity Adjacent Channel –10 k (dB) = VRF2 – VRF0.
13. Selectivity Adjacent Channel  $\pm 10$  k = minimum (VRF1 – VRF0, VRF2 – VRF0).

**Notes:**

1. Generator #1 RF level is set to 40 dB $\mu$ V to be able to get selectivity results greater than 60 dB. This is not a limitation of the FM tuner or the evaluation board. Maximum RF level setting for the R&S SML01 signal generator is 120 dB $\mu$ V. You cannot increase the RF level beyond this value, so if VRF0 = 60 dB $\mu$ V, selectivity numbers would be limited to 60 dB.
2. For shortwave, the adjacent channel is defined as RF  $\pm 10$  k.
3. For the AM band with 10 kHz channel space, the adjacent channel will be 10 kHz away (RF  $\pm 10$  k).
4. For the AM band with 9 kHz channel space, the adjacent channel will be 9 kHz away (RF  $\pm 9$  k).

**5.6.3. Pass Criteria**

AM adjacent channel selectivity  $\pm 10$  kHz (or  $\pm 9$  kHz) should be no less than 52 dB.

SW adjacent channel selectivity  $\pm 10$  kHz should be no less than 35 dB.

**5.7. AM/SW Audio Frequency Response****5.7.1. Description**

Audio frequency response is the measure of linearity of output voltage vs. modulation frequency across the audio band.

**5.7.2. Conditions/Procedure**

1. Connect test equipment as shown in Figure 3 or Figure 6.
2. Configure the tuner in standard configuration.
3. Configure the audio analyzer:
  - a. Select Analyze.
  - b. Set Function = RMS Select.
    - i. Set Bandwidth = BP 3%.
    - ii. Set Units = dBV.
    - iii. Set Frequency Mode = FIX: 1 kHz.
4. Configure generator #1:
  - a. Set carrier frequency = 1000 kHz (11.85 MHz for shortwave).
  - b. Set RF level VRF0 = 74 dB $\mu$ V<sub>emf</sub>.
  - c. Select AM Modulation.
    - i. Set AM Modulation Depth = 30%.
    - ii. Set source = LFGEN.
    - iii. Set LFGEN frequency = 1 kHz.
  - d. Enable AM modulation.
  - e. Enable RF carrier.
5. Audio 1 kHz level (dBV) = V1 kHz.
6. Configure audio analyzer frequency mode through RMS Select Function. Set Frequency Mode = FIX: 50 Hz.
7. Configure generator LFGEN frequency = 50 Hz.
8. Audio 50 Hz level (dBV) = V50 Hz.
9. Configure audio analyzer frequency mode through RMS Select Function. Set Frequency Mode = FIX: 3 kHz.
10. Configure generator LFGEN frequency = 3 kHz.

11. Audio 3 kHz level (dBV) = V3 kHz.

12. Audio frequency response (dB) equals the greater magnitude of (V50Hz – V1kHz) and (V3kHz – V1kHz).

### 5.7.3. Pass Criteria

The greater magnitude of (V50Hz – V1kHz) and (V3kHz – V1kHz) should be no more than 20 dB.

## 5.8. AM/SW THD

### 5.8.1. Description

The test measures AM/SW THD at an RF Level of 74 dB $\mu$ Vemf.

### 5.8.2. Conditions/Procedure

1. Connect test equipment as shown in Figure 3 or Figure 6.
2. Configure the tuner in standard configuration.
3. Configure the audio analyzer:
  - a. Select Analyze.
  - b. Set Function = THD.
    - i. Set Measurement Mode = All di (all harmonics).
    - ii. Set Unit = %.
4. Configure generator:
  - a. Set carrier frequency = 1000 kHz (11.85 MHz for shortwave).
  - b. Select AM Modulation.
    - i. Set AM Modulation Depth = 30%.
    - ii. Set Source = LFGEN.
    - iii. Set LFGEN frequency = 1 kHz.
  - c. Set RF level = 74 dB $\mu$ Vemf.
  - d. Enable AM modulation.
  - e. Enable RF (carrier).
5. Record THD (%).

### 5.8.3. Pass Criteria

AM/SW THD should be no more than 0.5%.



## 5.9. AM/SW THD at High Modulation Depth

### 5.9.1. Description

The test measures AM/SW THD at 90% modulation depth.

### 5.9.2. Conditions/Procedure

1. Connect test equipment as shown in Figure 3 or Figure 6.
2. Configure the tuner in standard configuration.
3. Configure the audio analyzer:
  - a. Select Analyze.
  - b. Set Function = THD.
    - i. Set Measurement Mode = All di (all harmonics).
    - ii. Set Unit = %.
4. Configure generator:
  - a. Set carrier frequency = 1000 kHz (11.85 MHz for shortwave).
  - b. Select AM Modulation.
    - i. Set AM Modulation Depth = 90%.
    - ii. Set Source = LFGEN.
    - iii. Set LFGEN frequency = 1 kHz.
  - c. Set RF level = 74 dB $\mu$ Vemf.
  - d. Enable AM modulation.
  - e. Enable RF (carrier).
5. Adjust volume control wheel to get audio output level RMS = -14 dBV.
6. Record THD (%).

### 5.9.3. Pass Criteria

AM/SW THD at high modulation depth should be no more than 0.5%.

## 5.10. AM/SW Audio Output Voltage

### 5.10.1. Description

The test measures AM/SW Audio Volume Level at an RF Level of 74 dB $\mu$ Vemf.

### 5.10.2. Conditions/Procedure

1. Connect test equipment as shown in Figure 3 or Figure 6.
2. Configure the tuner in standard configuration.
3. Configure the audio analyzer:
  - a. Select Analyze.
  - b. Set Function = THD+N/SINAD.
    - i. Set Measurement Mode = SINAD.
    - ii. Set Unit = dB.
    - iii. Set Filter = A-weighting.
    - iv. Set Frequency Limit Low = 300 Hz.
    - v. Set Frequency Limit High = 15000 Hz.
4. Configure generator:
  - a. Set carrier frequency = 1000 kHz. (11.85 MHz for shortwave)
  - b. Select AM Modulation.
    - i. Set AM Modulation Depth = 30%.
    - ii. Set Source = LFGEN.
    - iii. Set LFGEN frequency = 1 kHz.
  - c. Set RF level = 74 dB $\mu$ Vemf.
  - d. Enable AM modulation.
  - e. Enable RF (carrier).
5. Test the audio voltage at FM tuner audio output pin Lout or Rout.

### 5.10.3. Pass Criteria

Tuner AM/SW audio output level is between 54 and 67 mVrms.

## 5.11. AM/SW Audio SNR

### 5.11.1. Description

The test measures AM/SW SNR performance with a desired signal with RF Level of 74 dB $\mu$ Vemf.

### 5.11.2. Conditions/Procedure

1. Connect test equipment as shown in Figure 3 or Figure 6.
2. Configure the tuner in standard configuration.
3. Configure the audio analyzer:
  - a. Select Analyze.
  - b. Set Function = THD+N/SINAD.
    - i. Set Measurement Mode = Noise.
    - ii. Set Unit = dB.
    - iii. Set Filter = A-weighting.
    - iv. Set Frequency Limit Low = 300 Hz.
    - v. Set Frequency Limit High = 15000 Hz.
4. Configure generator:
  - a. Set carrier frequency = 1000 kHz (11.85 MHz for shortwave).
  - b. Select AM Modulation.
    - i. Set AM Modulation Depth = 30%.
    - ii. Set Source = LFGEN.
    - iii. Set LFGEN frequency = 1 kHz.
  - c. Set RF level = 74 dB $\mu$ Vemf.
  - d. Enable AM modulation.
  - e. Enable RF carrier.
5. Record SNR (dB) = Noise (dB).

### 5.11.3. Pass Criteria

AM/SW SNR should be no less than 52 dB.

## 5.12. AM/SW SINAD

### 5.12.1. Description

The test measures AM SINAD with the desired signal at an RF Level of 74 dB $\mu$ Vemf.

### 5.12.2. Conditions/Procedure

1. Connect test equipment as shown in Figure 3 or Figure 6.
2. Configure the tuner in standard configuration.
3. Configure the audio analyzer:
  - a. Select Analyze.
  - b. Set Function = THD+N/SINAD.
    - i. Set Measurement Mode = SINAD.
    - ii. Set Unit = dB.
    - iii. Set Filter = A-weighting.
    - iv. Set Frequency Limit Low = 300 Hz.
    - v. Set Frequency Limit High = 15000 Hz.
4. Configure generator:
  - a. Set carrier frequency = 1000 kHz (11.85 MHz for shortwave).
  - b. Select AM Modulation.
    - i. Set AM Modulation Depth = 30%.
    - ii. Set Source = LFGEN.
    - iii. Set LFGEN frequency = 1 kHz.
  - c. Set RF level = 74 dB $\mu$ Vemf.
  - d. Enable AM modulation.
  - e. Enable RF carrier.
5. Record SINAD (dB) = SINAD (dB).

### 5.12.3. Pass Criteria

AM/SW SINAD should be more than 50 dB.

## 5.13. AM/SW SINAD at High Modulation Depth

### 5.13.1. Description

The test measures AM/SW SINAD with the desired signal at an RF Level of 74 dB $\mu$ Vemf and modulation depth of 90%.

### 5.13.2. Conditions/Procedure

1. Connect test equipment as shown in Figure 3 or Figure 6.
2. Configure the tuner in standard configuration.
3. Configure the audio analyzer:
  - a. Select Analyze.
  - b. Set Function = THD+N/SINAD.
    - i. Set Measurement Mode = SINAD.
    - ii. Set Unit = dB.
    - iii. Set Filter = A-weighting.
    - iv. Set Frequency Limit Low = 300 Hz.
    - v. Set Frequency Limit High = 15000 Hz.
4. Configure generator:
  - a. Set carrier frequency = 1000 kHz (11.85 MHz for shortwave).
  - b. Select AM Modulation.
    - i. Set AM Modulation Depth = 90%.
    - ii. Set Source = LFGEN.
    - iii. Set LFGEN frequency = 1 kHz.
  - c. Set RF level = 74 dB $\mu$ Vemf.
  - d. Enable AM modulation.
  - e. Enable RF carrier.
5. Adjust volume control wheel to get audio output level RMS = -14 dBV.
6. Record SINAD (dB) = SINAD (dB).

### 5.13.3. Pass Criteria

AM/SW SINAD at high modulation depth should be more than 40 dB.

## 5.14. AM/SW Tuning Indicator Sensitivity

### 5.14.1. Description

The test measures the needed RF input level to turn on the tuning indicator.

### 5.14.2. Conditions/Procedure

1. Connect test equipment as shown in Figure 3 or Figure 6.
2. Configure the tuner in standard configuration.
3. Configure the audio analyzer:
  - a. Select Analyze.
  - b. Set Function = THD+N/SINAD.
    - i. Set Measurement Mode = SINAD.
    - ii. Set Unit = dB.
    - iii. Set Filter = A-weighting.
    - iv. Set Frequency Limit Low = 300 Hz.
    - v. Set Frequency Limit High = 15000 Hz.
4. Configure generator:
  - a. Set carrier frequency = 1000 kHz (11.85 MHz for shortwave).
  - b. Select AM Modulation.
    - i. Set AM Modulation Depth = 30%.
    - ii. Set Source = LFGEN.
    - iii. Set LFGEN frequency = 1 kHz.
  - c. Set RF level = 60 dB $\mu$ V.
  - d. Enable AM modulation.
  - e. Enable RF carrier.
5. Decrease signal generator RF level until the tuning indicator turns off.
6. Increase signal generator RF level VRF0 from low to high until tuning indicator turns on.
7. Tuning indicator sensitivity = VRF0.

### 5.14.3. Pass Criteria

AM Tuning indicator sensitivity should be no more than 22 dB $\mu$ V.

SW Tuning indicator sensitivity should be no more than 20 dB $\mu$ V.

## DOCUMENT CHANGE LIST:

### Revision 0.2 to Revision 0.3

- Updated the title.
- Updated figures 1-7.
- Updated "1. Introduction"
- Updated "2. FM Tuner Testing Setup"
- Updated "3.1. FM Tuning Frequency Range"
- Updated "4. AM/SW Tuner Testing Setup"
- Updated "5.1 AM/SW Tuning Frequency Range"
- Updated "5.5 AM/SW Selective –6 dB"

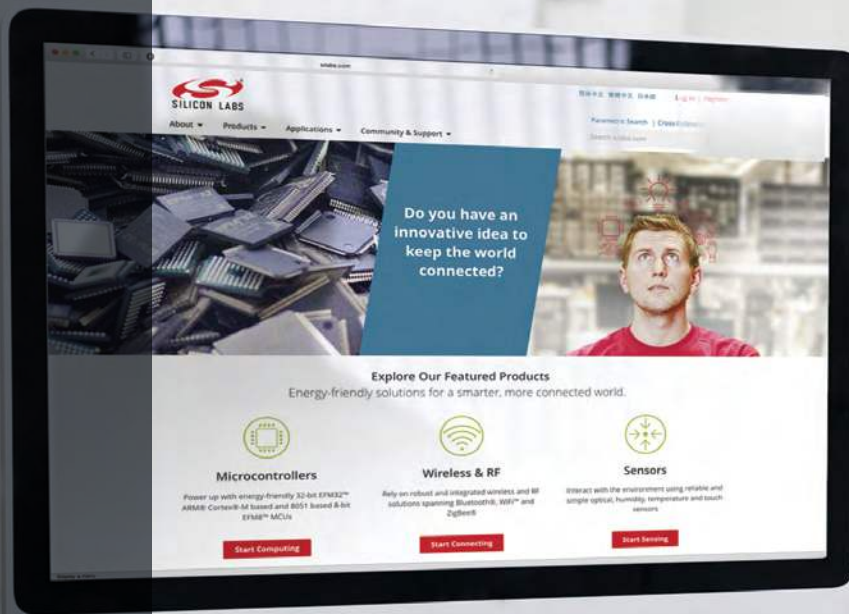

Smart.  
Connected.  
Energy-Friendly



**Products**  
[www.silabs.com/products](http://www.silabs.com/products)

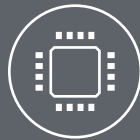

**Quality**  
[www.silabs.com/quality](http://www.silabs.com/quality)



**Support and Community**  
[community.silabs.com](http://community.silabs.com)

#### Disclaimer

Silicon Laboratories intends to provide customers with the latest, accurate, and in-depth documentation of all peripherals and modules available for system and software implementers using or intending to use the Silicon Laboratories products. Characterization data, available modules and peripherals, memory sizes and memory addresses refer to each specific device, and "Typical" parameters provided can and do vary in different applications. Application examples described herein are for illustrative purposes only. Silicon Laboratories reserves the right to make changes without further notice and limitation to product information, specifications, and descriptions herein, and does not give warranties as to the accuracy or completeness of the included information. Silicon Laboratories shall have no liability for the consequences of use of the information supplied herein. This document does not imply or express copyright licenses granted hereunder to design or fabricate any integrated circuits. The products must not be used within any Life Support System without the specific written consent of Silicon Laboratories. A "Life Support System" is any product or system intended to support or sustain life and/or health, which, if it fails, can be reasonably expected to result in significant personal injury or death. Silicon Laboratories products are generally not intended for military applications. Silicon Laboratories products shall under no circumstances be used in weapons of mass destruction including (but not limited to) nuclear, biological or chemical weapons, or missiles capable of delivering such weapons.

#### Trademark Information

Silicon Laboratories Inc., Silicon Laboratories, Silicon Labs, SiLabs and the Silicon Labs logo, CMEMS®, EFM, EFM32, EFR, Energy Micro, Energy Micro logo and combinations thereof, "the world's most energy friendly microcontrollers", Ember®, EZLink®, EZMac®, EZRadio®, EZRadioPRO®, DSPLL®, ISOmodem®, Precision32®, ProSLIC®, SiPHY®, USBXpress® and others are trademarks or registered trademarks of Silicon Laboratories Inc. ARM, CORTEX, Cortex-M3 and THUMB are trademarks or registered trademarks of ARM Holdings. Keil is a registered trademark of ARM Limited. All other products or brand names mentioned herein are trademarks of their respective holders.



**SILICON LABS**

Silicon Laboratories Inc.  
400 West Cesar Chavez  
Austin, TX 78701  
USA

<http://www.silabs.com>