

THIS DRAWING IS UNPUBLISHED. RELEASED FOR PUBLICATION
 © COPYRIGHT - By - ALL RIGHTS RESERVED.

REVISIONS					
P	LTR	DESCRIPTION	DATE	DWN	APVD
C1		REVISED PER ECO-11-005027	11MAR11	RK	HMR
C2		REVISED PER ECO-18-000204	08JAN2018	RS	DR

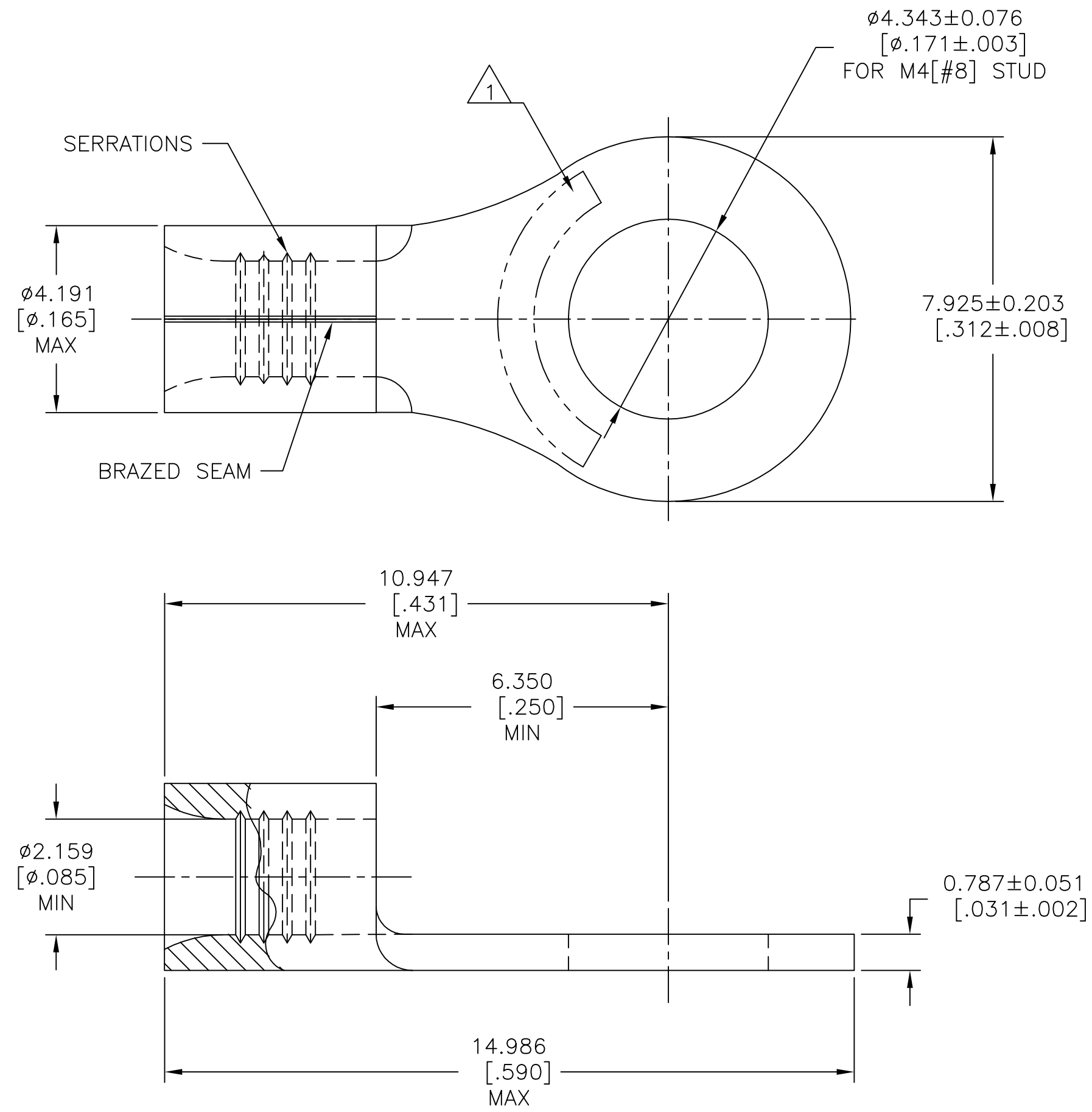

AMP WIRE RANGE	E13288 Listed
16-14 AWG SOLID OR STRANDED	16-14 AWG SOLID OR STRANDED
LR7189 Certified	MILITARY P/N AND CLASS
16-14 AWG SOLID OR STRANDED	NOT APPLICABLE

STAMP AMP 16-14* APPROX AS SHOWN.

AMP INCORPORATED
CUSTOMER SERVICE SYSTEMS

MAX RECOMMENDED OPERATING TEMPERATURE:
170°C[338°F] MAX

FOR ADDITIONAL PRODUCT INFORMATION OR COPIES OF DRAWINGS AND TECHNICAL DOCUMENTS

PRODUCT INFORMATION CENTER
1-800-522-6752

VOLTAGE RATING:
NOT APPLICABLE

FOR APPLICATION TOOLING INFORMATION

TOOLING ASSISTANCE CENTER
1-800-722-1111

WIRE CROSS SECTIONAL AREA RANGE:
1.04-2.62mm²[2,050-5,180] CIR MILS
SOLID OR STRANDED

FOR ORDER ENTRY

1-800-526-5142

THIS DRAWING IS A CONTROLLED DOCUMENT FOR AMP INCORPORATED. IT IS SUBJECT TO CHANGE AND THE CONTROLLING ENGINEERING ORGANIZATION SHOULD BE CONTACTED FOR THE LATEST REVISION.

QUANTITY	PACKAGE TYPE	PART NO
100	LOOSE PIECE, BOX	8-324955-1
5000	ON TAPE	2-324955-1
1000	LOOSE PIECE	324955

THIS DRAWING IS A CONTROLLED DOCUMENT.		DWN TA BRINKMAN 3-17-93	TE Connectivity	
DIMENSIONS: mm [INCHES]		CHK DA PATTERSON 3-17-93		
TOLERANCES UNLESS OTHERWISE SPECIFIED:		APVD DE MILLER 3-17-93	NAME	
0 PLC ± -		PRODUCT SPEC	TERMINAL, RING TONGUE, SOLISTRAND,™	
1 PLC ± -		APPLICATION SPEC	16-14 AWG	
2 PLC ± -			SIZE	CAGE CODE
3 PLC ± 0.127[.005]			A2	00779
4 PLC ± -			DRAWING NO	RESTRICTED TO
ANGLES ± -			C=324955	-
FINISH		WEIGHT	SCALE	SHEET
COPPER PER ASTM B-152 ANNEALED		-	10:1	1 of 1
TIN PLATE 0.00254[.000100] MIN THK PER ASTM B-545		CUSTOMER DRAWING	REV	C2