



CFB400W SERIES

400W WATTS 4:1 INPUT DC-DC CONVERTERS SINGLE OUTPUT



FEATURES

- * 400W Isolated Output
- * Efficiency to 90%
- * Fixed Switching Frequency
- * Input Under Voltage Protection
- * Over Temperature Protection
- * Over Voltage/Current Protection
- * Remote On/Off
- * Full-Brick Size Meet Industry Standard
- * Fully Isolated 1500VDC
- * Without Tantalum Capacitor Inside
- * UL60950-1 Approval



MODEL NUMBER	INPUT VOLTAGE	OUTPUT VOLTAGE	OUTPUT CURRENT		INPUT CURRENT		(%) EFF.		CAPACITIVE LOAD MAX. (4, 5, 6)
			MIN.	MAX.	NO LOAD	FULL LOAD	(2)	(3)	
CFB400W-24S05	9-36 VDC	5 VDC	0 mA	80 A	600 mA	19.05 A	86.5	87.5	10000uF
CFB400W-24S12	9-36 VDC	12 VDC	0 mA	33.3 A	120 mA	19.36 A	85	86	10000uF
CFB400W-24S24	9-36 VDC	24 VDC	0 mA	16.7 A	120 mA	19.19 A	88	87	4700uF
CFB400W-24S28	9-36 VDC	28 VDC	0 mA	14.3 A	120 mA	19.18 A	86.5	87	4700uF
CFB400W-24S48	9-36 VDC	48 VDC	0 mA	8.3 A	120 mA	19.19 A	85.5	86.5	2200uF
CFB400W-48S05	18-75 VDC	5 VDC	0 mA	80 A	300 mA	9.36 A	88.5	89	10000uF
CFB400W-48S12	18-75 VDC	12 VDC	0 mA	33.3 A	60 mA	9.41 A	88.5	88.5	10000uF
CFB400W-48S24	18-75 VDC	24 VDC	0 mA	16.7 A	60 mA	9.28 A	90	90	4700uF
CFB400W-48S28	18-75 VDC	28 VDC	0 mA	14.3A	60 mA	9.27 A	90.5	90	4700uF
CFB400W-48S48	18-75 VDC	48 VDC	0 mA	8.3 A	60 mA	9.27 A	88	89.5	2200uF

NOTE:

1. Nominal Input Voltage 24, 48 VDC.
2. Measured at 12VDC for 24Vin, 24VDC for 48Vin.
3. Measured at Nominal Input Voltage.
4. The output terminal of 12V, 24V, 28V Vout models required a minimum capacitor 330uF to maintain specified regulation.
5. The output terminal of 5Vout models required a minimum capacitor 680uF to maintain specified regulation.
6. The output terminal of 48Vout models required a minimum capacitor 100uF to maintain specified regulation.

SPECIFICATIONS

All Specifications Typical At Nominal Line, Full Load, and 25°C Unless Otherwise Noted

INPUT SPECIFICATIONS:

Input Voltage Range	24V	9-36V
	48V	18-75V
Under Voltage Lockout	24Vin power up	8.5V
	24Vin power down	7.5V
	48Vin power up	17V
	48Vin power down	15V
Input Over Voltage Protection	24Vin Turn off ...	42V, Turn on ... 40V
	48Vin Turn off ...	83V, Turn on ... 80V

Opto Isolated Remote On/Off (note6)

Input Filter LC Type

OUTPUT SPECIFICATIONS:

Voltage Accuracy	±1.0% max.
Transient Response: 25% Step Load Change	<500µs
External Trim Adj. Range	80-110%
Load Share Accuracy	±10% at 50% to 100% Full Load

Auxiliary Output Voltage/Current 10±3Vdc/20mA max.

Ripple & Noise, 20MHz BW (note3)

5V	40mV RMS max., 100mV pk-pk max.
12V	60mV RMS max., 120mV pk-pk max.
24V	100mV RMS max., 240mV pk-pk max.
28V	100mV RMS max., 280mV pk-pk max.
48V	120mV RMS max., 480mV pk-pk max.

Temperature Coefficient ±0.03%/°C max.

Short Circuit Protection Continuous

Line Regulation (note1) ±0.2% max.

Load Regulation (note2) ±0.5% max.

Over Voltage Protection Trip Range, % Vo nom. 115-140%

Current Limit 110%-150% Nominal Output

Start up time 120ms typ.

CASE FB

Tolerances Inches: XX±0.02 .XXX±0.010 ±0.004
Millimeters: X±0.5 .XX±0.25 ±0.1

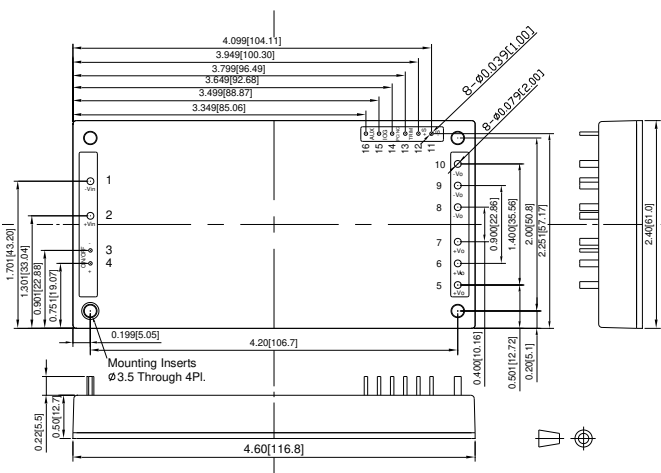

PIN CONNECTIONS	
PIN NUMBER	FUNCTION
1	-V Input
2	+V Input
3	-On/Off
4	+On/Off
5 - 7	+V Output
8 - 10	-V Output
11	-S
12	+S
13	TRIM
14	PC/NC
15	IOG
16	AUX

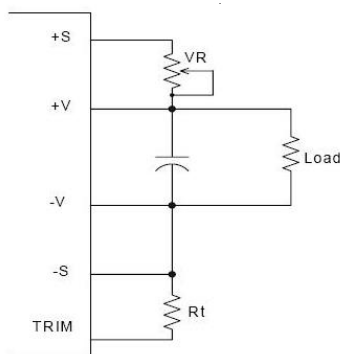

The output voltage can be determined by below equations:

$$V_f = \frac{1.24 \times \left(\frac{R_t \times 33}{R_t + 33} \right)}{7.68 + \frac{R_t \times 33}{R_t + 33}}$$

$$V_{out} = (V_o + V_R) \times V_f$$

Unit: KΩ
Vo: Nominal Output Voltage
Rt=6.8KΩ

Fig.1 The schematic of output voltage adjusted by using external resistor and/or variable resistor.

GENERAL SPECIFICATIONS:

Efficiency	See Table
Isolation Voltage	Input/Output 1500VDC min. Input/Case 1500VDC min. Output/Case 1500VDC min.
Isolation Resistance	10 ⁷ ohm min.
Isolation Capacitance	4000pF typ.
Switching Frequency	230KHz typ.
Operating Case Temperature	-40°C to 100°C
Storage Temperature	-55°C to +110°C
Thermal Shutdown Case Temp.	110°C typ.
Humidity	95% RH max. Non condensing
MTBF	MIL-HDBK-217F, GB, 25°C, Full Load 340Khrs typ.
Dimensions	4.60×2.40×0.50 inches (116.8×61.0×12.7 mm)
Case Material	Aluminum Baseplate with Plastic Case
Weight	220g

NOTE :

1. Measured from high line to low line.
2. Measured from full load to zero load.
3. Output ripple and noise measured with 10uF tantalum and 1uF ceramic capacitor across output.
4. The output adjustment circuit and trim equations show as figure1 and figure2.
5. An external input capacitor 1000uF for 24Vin or 330uF for 48Vin models are recommended to reduce input ripple voltage.
6. Standard model is negative logic , suffix "P" to the model number with positive logic. (refer application note)
7. If the remote sense feature is not to be used, the +sense pin should be connected to the +Vout pin and the -sense pin should be connected to the -Vout pin. (refer application note)

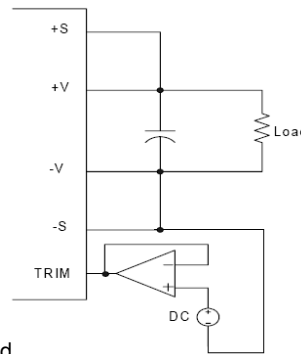

Output Voltage = TRIM Terminal Voltage * Nominal Output Voltage

Fig.2 The schematic of output voltage adjusted by using external DC voltage.