

PRODUCT DATA DRAWING

REVISION HISTORY			
REV	DESCRIPTION	DATE	APPROVED
B	DCN 40176	11/13	STW
C	DCN 49533	1/20	STW

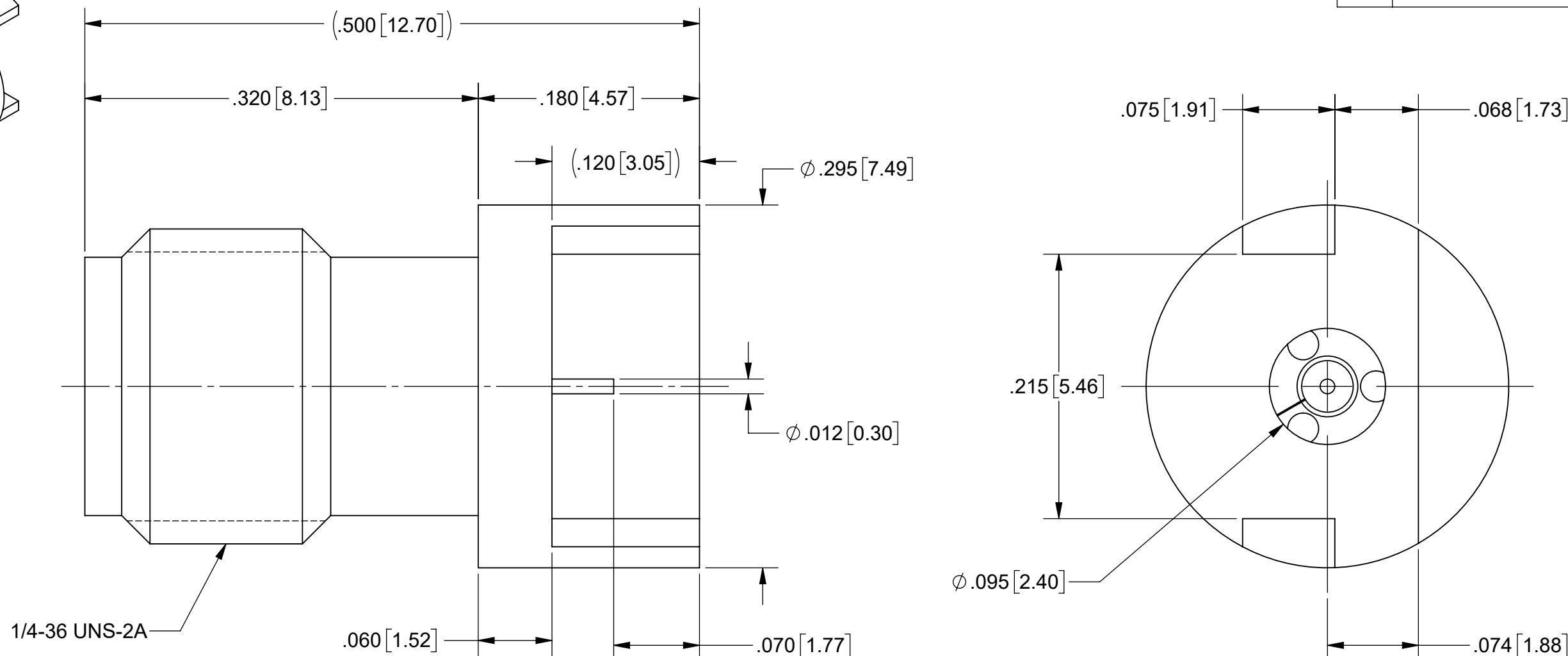
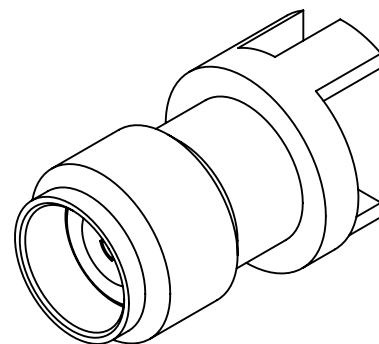

MATERIAL:

BODY & INSERT: STAINLESS STEEL PER AMS-5640, ALLOY UNS S30300, TYPE 1

CONTACT: BERYLLIUM COPPER PER ASTM B196, ALLOY No. UNS C17300, TD04

DIELECTRIC BEAD: ULTEM 1000

FINISH:

BODY, INSERT & CONTACT: GOLD PER ASTM B 488, TYPE II, CODE C, CLASS 0.76, OVER NICKEL PER AMS-QQ-N-290, CLASS 1, .00010" MIN.

PERFORMANCE:

FREQ. RANGE: DC TO 30.0 GHz
VSWR: 1.25:1 MAX. DC TO 30.0 GHz.

NOTES:
 1. FOR RECOMMENDED FOOTPRINT FO YOUR SPECIFIC PCB, CONTACT SV MICROWAVE SALES DEPARTMENT (sales@svmicro.com, 561-840-1800).

MATERIAL: SEE NOTES	DIMENSIONS ARE IN INCHES TOLERANCES: FRACTIONAL: $\pm 1/64$ ANGULAR: X° $\pm 1'0"$ X'X' $\pm 15'$	UNLESS OTHERWISE SPECIFIED 1) ALL DIMENSIONS ARE IN INCHES (MILLIMETERS) 2) ALL DIMENSIONS ARE AFTER PLATING. 3) BREAK CORNERS & EDGES .005 R. MAX. 4) CHAM. 1ST & LAST THREADS. 5) SURFACE ROUGHNESS 63-MIL-STD-10. 6) DIA: 'S ON COMMON CENTERS TO BE CONCENTRIC WITHIN .005 T.I.R. 7) REMOVE ALL BURRS	SV Microwave, Inc. 2400 Centrepark West Drive, Suite 100 West Palm Beach, FL 33409
FINISH: SEE NOTES	DECIMAL: .X $\pm .030$.XX $\pm .010$.XXX $\pm .005$	INTERPRET DIMENSIONS AND TOLERANCES PER ASME Y14.5M - 1994	TITLE: SVK JACK PCB MOUNT Ø.012 PIN FOR .062" PCB
SURFACE AREA: N/A	THIRD ANGLE PROJECTION	DRAWN: FSG 09/24/12	SIZE: B CAGE CODE: 95077 DWG. NO.: 1521-60051
PROPRIETARY THE INFORMATION CONTAINED IN THIS DRAWING IS THE SOLE PROPERTY OF SV MICROWAVE, INC. ANY REPRODUCTION IN PART OR AS A WHOLE WITHOUT THE WRITTEN PERMISSION OF SV MICROWAVE, INC IS PROHIBITED.		CHECKED: STW 09/24/12	SCALE: 4:1
		APPROVED: STW 09/24/12	SHEET 1 OF 1