

COUNT	DESCRIPTION OF REVISIONS	BY	CHKD	DATE	COUNT	DESCRIPTION OF REVISIONS	BY	CHKD	DATE
2	RE-C-03960	H.Z	M.S	04.12.1					

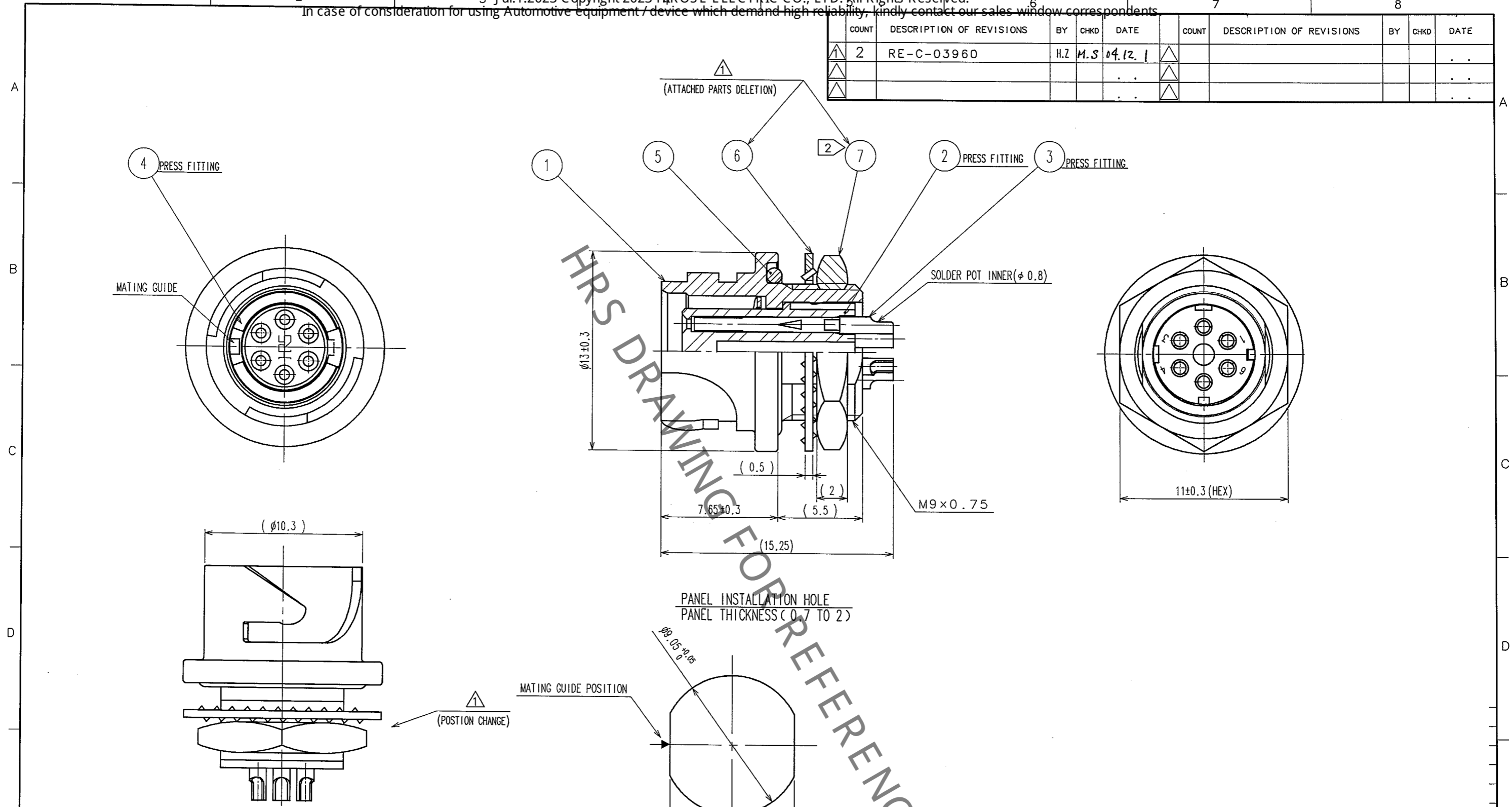

NOTES

- PLATING(REF.NO. ③)  
CONTACT AREA : GOLD 0.2μ m min  
OTHERS : GOLD AND NICKEL  
UNDER PLATING : NICKEL 2μ m min
- THE RECOMMENDED CLAMP TORQUE OF REF.NO. ⑦ TO BE 1.5 TO 2N · m.  
THREAD LOCKER TO THE THREADED PORTION OF REF.NO. ① IS RECOMMENDED TO PREVENT REF.NO. ⑦ FROM LOOSING.  
RECOMMENDED THREAD LOCKER:LOCTITE 271, HENKEL JAPAN LTD.
- WHEN THIS CONNECTOR IS MOUNTED ON TO PANEL, BE CAREFUL REF.NO. ⑤ IS ASSEMBLED SURELY INTO THE GROOVE OF REF.NO. ① AS SHOWN IN THIS FIGURE TO KEEP WATERPROOF EFFECTIVENESS.

NO.	MATERIAL	FINISH, REMARKS	NO.	MATERIAL	FINISH, REMARKS
4	PHOSPHOR BRONZE	NICKEL PLATING	7	STEEL	NICKEL PLATING
3	PHOSPHOR BRONZE	①	6	STEEL	NICKEL PLATING
2	PPS	(BLACK) UL94V-0	5	CHLOROPRENE RUBBER	(BLACK)
1	ZINC ALLOY	NICKEL PLATING			

CODE NO. (OLD) CL	DRAWN H.Kawashima	DESIGNED H.Zemba	CHECKED M.Sato	APPROVED M.Yoshida	RELEASED .
	04.05.24	04.05.28	04.05.31	04.05.31	.

DRAWING NO. EDC3-113851	PART NO. LF07WBR-6S
SCALE 4 : 1	CODE NO. CL136-1002-0
UNITS mm	

TO  
R