

# NHD-0440AZ-NLY-FBW-C6

## Character Liquid Crystal Display Module

NHD-	Newhaven Display
0440-	4 lines x 40 characters
AZ-	Model
N-	Transmissive
LY-	Lower Yellow/Green LED Backlight
F-	FSTN (-)
B-	6:00 view
W-	Wide Temp. (-20°C~+70°C)
C-	2x8 Pin FCI part # 88874-016, shrouded header, 30u gold, right-angle, lead free, 5.84mm mating length. Header soldered onto component side of LCD PCB.
6-	R6= 3.3k ohm resistor

**RoHS Compliant**

**Newhaven Display International, Inc.**

2511 Technology Drive, Suite 101

Elgin IL, 60124

Ph: 847-844-8795

Fax: 847-844-8796

[www.newhavendisplay.com](http://www.newhavendisplay.com)

[nhtech@newhavendisplay.com](mailto:nhtech@newhavendisplay.com)

[nhsales@newhavendisplay.com](mailto:nhsales@newhavendisplay.com)

## Document Revision History

Revision	Date	Description	Changed by
0	10/21/2008	Initial Release	-
1	10/29/2009	User Guide Reformat	MC
2	11/17/2009	Updated Block diagram and initialization code	MC
3	12/16/2009	Updated Backlight Supply Voltage and Current	MC

## Functions and Features

- 4 lines x 40 characters
- 2 Built-in controllers (SPLC780D or equivalent)
- +5.0V Power Supply
- 1/16 duty, 1/5 bias
- RoHS compliant

# Mechanical Drawing

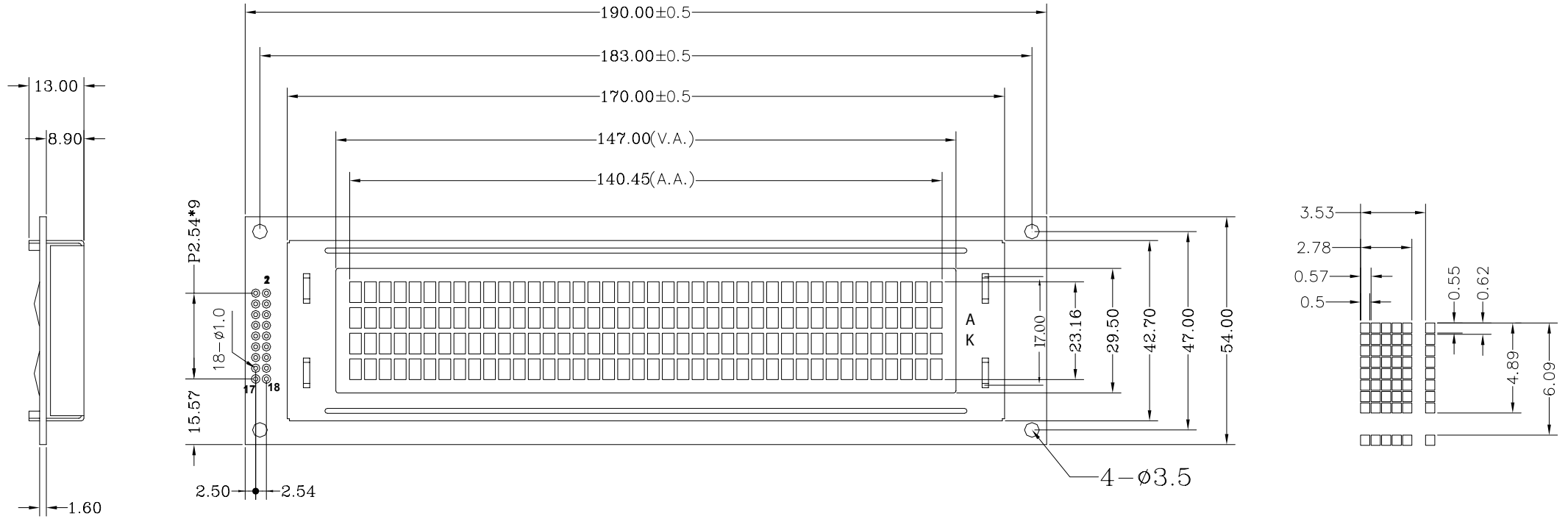

**Newhaven Display**  
NHD-0440AZ-NLY-FBW-C6

## Pin Description and Wiring Diagram

Pin No.	Symbol	External Connection	Function Description
1-4	DB7-DB4	MPU	Four high order bi-directional three-state data bus lines.
5-8	DB3-DB0	MPU	Four low order bi-directional three-state data bus lines. These four are not used during 4-bit operation.
9	E1	MPU	Operation enable signal. Falling edge triggered for top 2 lines.
10	R/W	MPU	Read/Write select signal, R/W=1: Read R/W:=0: Write
11	RS	MPU	Register select signal. RS=0: Command, RS=1: Data
12	V0	Power Supply	Power supply for contrast (approx. 0V)
13	Vss	Power Supply	Ground
14	VDD	Power Supply	Supply voltage for logic (+5.0V)
15	E2	MPU	Operation enable signal. Falling edge triggered for bottom 2 lines.
16	NC	-	No Connect
17	LED+	Power Supply	Power supply for LED backlight (+5.0V via on-board resistor)
18	LED-	Power Supply	Ground for backlight

**Recommended LCD connector:** 2.54mm pitch pins

**Backlight connector:** ---      **Mates with:** ---

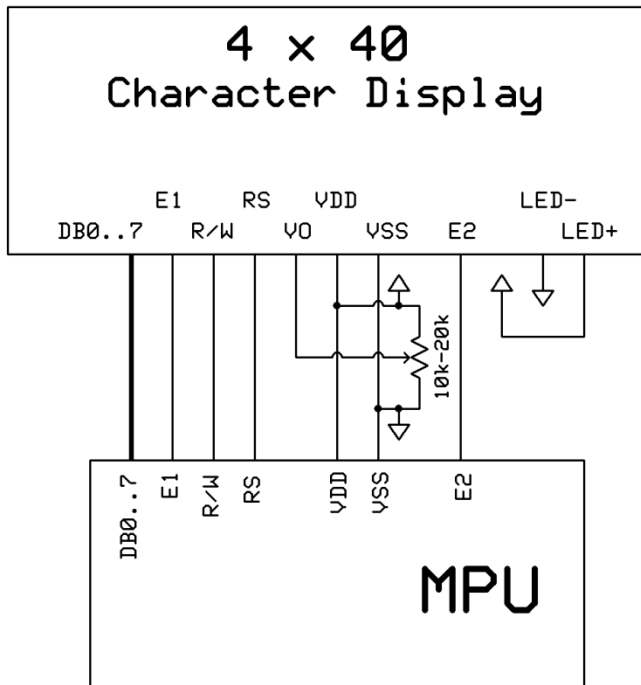

## Electrical Characteristics

Item	Symbol	Condition	Min.	Typ.	Max.	Unit
Operating Temperature Range	Top	Absolute Max	-20	-	+70	°C
Storage Temperature Range	Tst	Absolute Max	-30	-	+80	°C
Supply Voltage	VDD		2.7	5.0	5.5	V
Supply Current	IDD	Ta=25°C, VDD=5.0V	-	3.5	4.0	mA
Supply for LCD (contrast)	VDD-V0	Ta=25°C	-	5.0	-	V
"H" Level input	Vih		2.2	-	VDD	V
"L" Level input	Vil		0	-	0.6	V
"H" Level output	Voh		2.4	-	-	V
"L" Level output	Vol		-	-	0.4	V
Backlight Supply Voltage	Vled	-	-	5.0	5.0	V
Backlight Supply Current	Iled	Vled=5.0V	-	360	480	mA

## Optical Characteristics

Item	Symbol	Condition	Min.	Typ.	Max.	Unit
Viewing Angle – Vertical (top)	AV	Cr ≥ 3	-	20	-	°
Viewing Angle – Vertical (bottom)	AV	Cr ≥ 3	-	50	-	°
Viewing Angle – Horizontal (left)	AH	Cr ≥ 3	-	30	-	°
Viewing Angle – Horizontal (right)	AH	Cr ≥ 3	-	30	-	°
Contrast Ratio	Cr		3	5	-	-
Response Time (rise)	Tr	-	-	150	250	ms
Response Time (fall)	Tf	-	-	150	250	ms

## Controller Information

Built-in SPLC780D. Download specification at [http://www.newhavendisplay.com/app\\_notes/SPLC780D.pdf](http://www.newhavendisplay.com/app_notes/SPLC780D.pdf)

## Table of Commands

Instruction	Instruction Code										Description	Execution time (fosc=270KHz)	
	RS	R/W	DB7	DB6	DB5	DB4	DB3	DB2	DB1	DB0			
Clear Display	0	0	0	0	0	0	0	0	0	1	Write "20H" to DDRAM and set DDRAM address to "00H" from AC	1.52ms	
Return Home	0	0	0	0	0	0	0	0	0	1	-	Set DDRAM address to "00H" from AC and return cursor to its original position if shifted. The contents of DDRAM are not changed.	1.52ms
Entry Mode Set	0	0	0	0	0	0	0	0	1	I/D	S	Assign cursor moving direction and enable the shift of entire display	38μs
Display ON/OFF Control	0	0	0	0	0	0	0	1	D	C	B	Set display(D), cursor(C), and blinking of cursor(B) on/off control bit.	38μs
Cursor or Display Shift	0	0	0	0	0	1	S/C	R/L	-	-	-	Set cursor moving and display shift control bit, and the direction, without changing of DDRAM data.	38μs
Function Set	0	0	0	0	1	DL	N	F	-	-	-	Set interface data length (DL: 8bit/4-bit), numbers of display line (N: 2-line/1-line) and, display font type (F:5x10 dots/5x8 dots)	38μs
Set CGRAM Address	0	0	0	1	AC5	AC4	AC3	AC2	AC1	AC0	-	Set CGRAM address in address counter.	38μs
Set DDRAM Address	0	0	1	AC6	AC5	AC4	AC3	AC2	AC1	AC0	-	Set DDRAM address in counter	38μs
Read Busy Flag and Address Counter	0	1	BF	AC6	AC5	AC4	AC3	AC2	AC1	AC0	-	Whether during internal operation or not can be known by reading BF. The contents of address counter can also be read.	
Write Data to RAM	1	0	D7	D6	D5	D4	D3	D2	D1	D0	-	Write data into internal RAM (DDRAM/CGRAM).	38μs
Read Data from RAM	1	1	D7	D6	D5	D4	D3	D2	D1	D0	-	Read data from internal RAM (DDRAM/CGRAM).	38μs

Note: "-": don't care

DDRAM address:

															Display position				
1	2	3	4	5	-	-	-	-	-	-	-	-	-	-	36	37	38	39	40
00	01	02	03	04	-	-	-	-	-	-	-	-	-	-	23	24	25	26	27
40	40	41	42	43	-	-	-	-	-	-	-	-	-	-	63	64	65	66	67
00	01	02	03	04	-	-	-	-	-	-	-	-	-	-	23	24	25	26	27
40	40	41	42	43	-	-	-	-	-	-	-	-	-	-	63	64	65	66	67

DDRAM address

# Timing Characteristics

## Writing data from MPU to SPLC780D

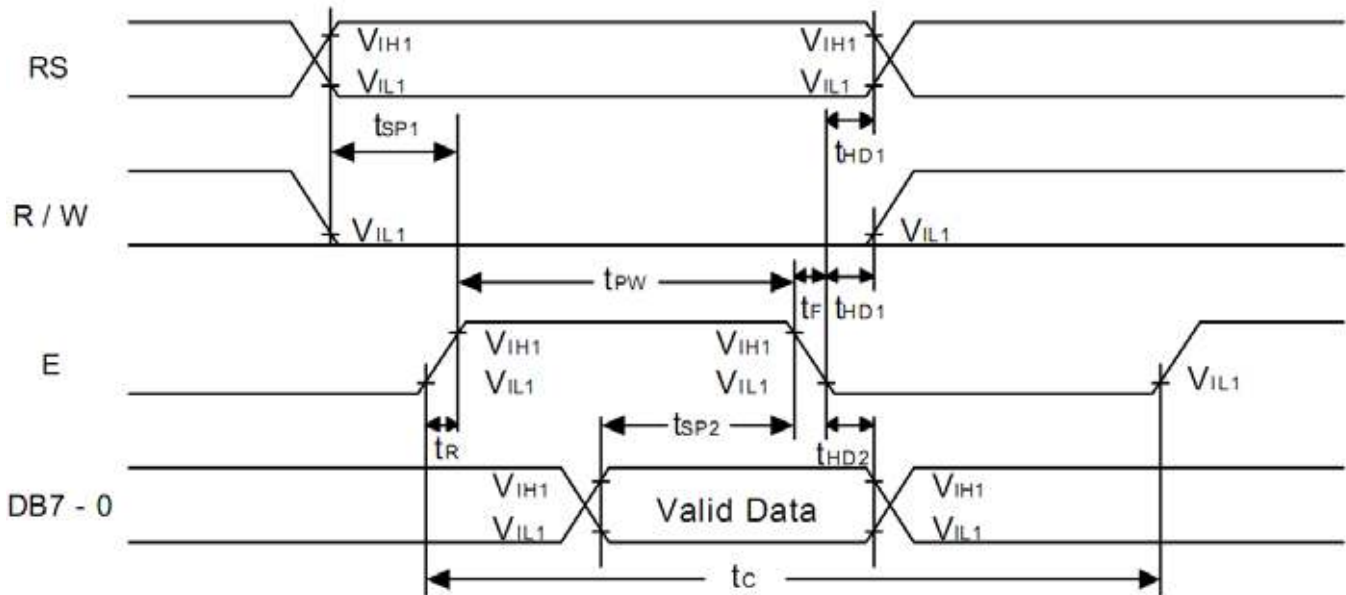

## Reading data from SPLC780D to MPU

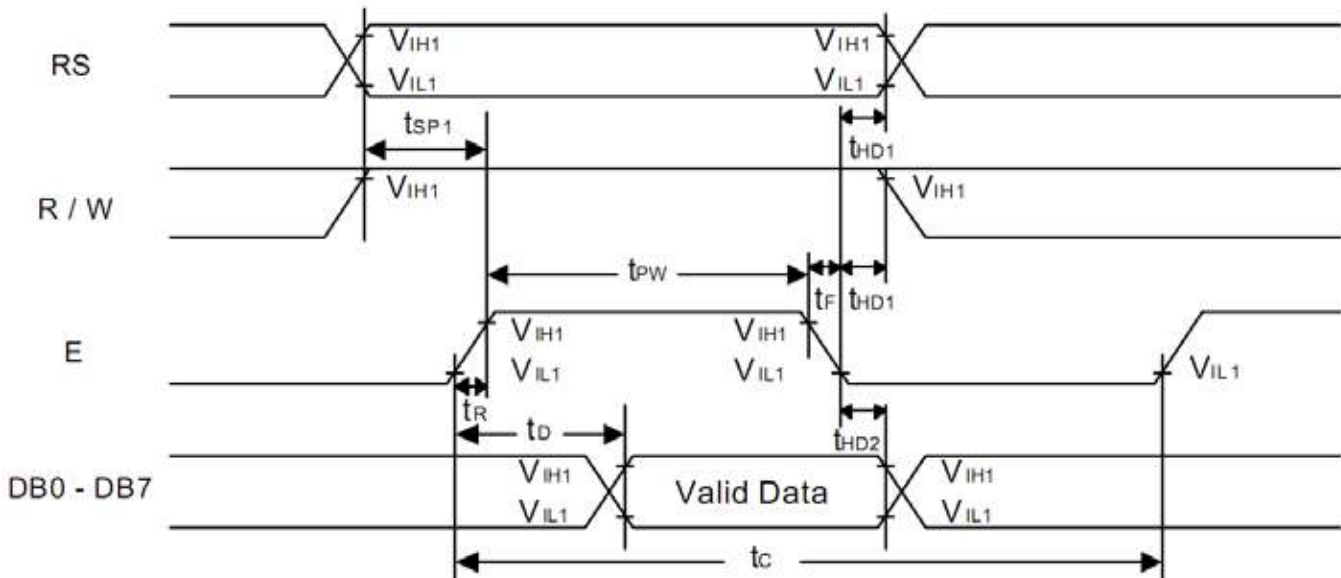

**Writing Data from MPU to SPLC780D.**

Characteristics	Symbol	Limit			Unit	Test Condition
		Min.	Typ.	Max.		
E Cycle Time	$t_c$	500	-	-	ns	Pin E
E Pulse Width	$t_{PW}$	230	-	-	ns	Pin E
E Rise/Fall Time	$t_R, t_F$	-	-	20	ns	Pin E
Address Setup Time	$t_{SP1}$	40	-	-	ns	Pins: RS, R/W, E
Address Hold Time	$t_{HD1}$	10	-	-	ns	Pins: RS, R/W, E
Data Setup Time	$t_{SP2}$	80	-	-	ns	Pins: DB0 - DB7
Data Hold Time	$t_{HD2}$	10	-	-	ns	Pins: DB0 - DB7

**Reading Data from SPLC780D to MPU.**

Characteristics	Symbol	Limit			Unit	Test Condition
		Min.	Typ.	Max.		
E Cycle Time	$t_c$	500	-	-	ns	Pin E
E Pulse Width	$t_W$	230	-	-	ns	Pin E
E Rise/Fall Time	$t_R, t_F$	-	-	20	ns	Pin E
Address Setup Time	$t_{SP1}$	40	-	-	ns	Pins: RS, R/W, E
Address Hold Time	$t_{HD1}$	10	-	-	ns	Pins: RS, R/W, E
Data Output Delay Time	$t_D$	-	-	120	ns	Pins: DB0 - DB7
Data hold time	$t_{HD2}$	5.0	-	-	ns	Pin DB0 - DB7



# Built-in Font Table

Lower 4 Bits \ Upper 4 Bits	0000	0001	0010	0011	0100	0101	0110	0111	1000	1001	1010	1011	1100	1101	1110	1111
xxxx0000	CG RAM (1)			0	a	P	`	P				-	夕	ミ	α	ρ
xxxx0001	(2)		!	1	A	Q	a	q			。	ア	チ	△	ä	q
xxxx0010	(3)		"	2	B	R	b	r			「	イ	ツ	×	ρ	θ
xxxx0011	(4)		#	3	C	S	c	s			」	ウ	テ	モ	ε	ε
xxxx0100	(5)		\$	4	D	T	d	t			、	エ	ト	ト	μ	Ω
xxxx0101	(6)		%	5	E	U	e	u			・	オ	ナ	1	ε	ü
xxxx0110	(7)		&	6	F	V	f	v			ヲ	カ	ニ	ヨ	ρ	Σ
xxxx0111	(8)		'	7	G	W	g	w			ヲ	キ	ヌ	ラ	g	π
xxxx1000	(1)		<	8	H	X	h	x			イ	ク	ネ	リ	γ	Σ
xxxx1001	(2)		>	9	I	Y	i	y			ウ	ケ	ル	ル	γ	γ
xxxx1010	(3)		*	:	J	Z	j	z			エ	コ	ハ	レ	j	≠
xxxx1011	(4)		+	:	K	[	k	<			オ	サ	ヒ	ロ	*	≠
xxxx1100	(5)		,	<	L	¥	l	l			カ	シ	フ	ワ	φ	≠
xxxx1101	(6)		-	=	M	]	m	>			ユ	ス	ハ	ン	も	÷
xxxx1110	(7)		.	>	N	^	n	→			ヨ	セ	ホ	°	ら	
xxxx1111	(8)		/	?	O	_	o	←			ッ	ソ	マ	°	ö	■

# Example Initialization Program

```
/******
```

```
void command1(char i)          //Top half of the display
```

```
{  
  
    P1 = i;  
  
    W = 0;  
  
    RS = 0;  
  
    E1 = 1;  
  
    delay(2);  
  
    E1 = 0;
```

```
}
```

```
void command2(char i)          //Bottom half of the display
```

```
{  
  
    P1 = i;  
  
    W = 0;  
  
    RS = 0;  
  
    E2 = 1;  
  
    delay(2);  
  
    E2 = 0;
```

```
}
```

```
/******
```

```
void writedata1(char i)        //Top half of the display
```

```
{  
  
    P1 = i;  
  
    W = 0;  
  
    RS = 1;  
  
    E1 = 1;  
  
    delay(2);  
  
    E1 = 0;
```

```
}
```

```
void writedata2(char i)        //Bottom half of the display
```

```
{  
  
    P1 = i;
```

```

W = 0;

RS = 1;

E2 = 1;

delay(2);

E2 = 0;

}

/*****/

void init_LCD()

{

    delay(15);

    command1(0x30);    //Wake up

    command2(0x30);

    delay(5);

    command1(0x30);    //Wake up

    command2(0x30);

    delay(5);

    command1(0x30);    //Wake up

    command2(0x30);

    delay(5);

    command1(0x38);    //Function Set = 8bit mode; 2-line; 5x8

    command2(0x38);

    command1(0x08);    //Turn off display

    command2(0x08);

    command1(0x01);    //Clear display

    command2(0x01);

    command1(0x06);    //Entry mode cursor increment

    command2(0x06);

    command1(0x0c);    //Turn on display; no cursor

    command2(0x0c);

}

/*****/

```

## Quality Information

Test Item	Content of Test	Test Condition	Note
High Temperature storage	Endurance test applying the high storage temperature for a long time.	+80°C , 48hrs	2
Low Temperature storage	Endurance test applying the low storage temperature for a long time.	-30°C , 48hrs	1,2
High Temperature Operation	Endurance test applying the electric stress (voltage & current) and the high thermal stress for a long time.	+70°C 48hrs	2
Low Temperature Operation	Endurance test applying the electric stress (voltage & current) and the low thermal stress for a long time.	-20°C , 48hrs	1,2
High Temperature / Humidity Operation	Endurance test applying the electric stress (voltage & current) and the high thermal with high humidity stress for a long time.	+40°C , 90% RH , 48hrs	1,2
Thermal Shock resistance	Endurance test applying the electric stress (voltage & current) during a cycle of low and high thermal stress.	0°C,30min -> 25°C,5min -> 50°C,30min = 1 cycle 10 cycles	
Vibration test	Endurance test applying vibration to simulate transportation and use.	10-55Hz , 15mm amplitude. 60 sec in each of 3 directions X,Y,Z For 15 minutes	3
Static electricity test	Endurance test applying electric static discharge.	VS=800V, RS=1.5kΩ, CS=100pF One time	

**Note 1:** No condensation to be observed.

**Note 2:** Conducted after 4 hours of storage at 25°C, 0%RH.

**Note 3:** Test performed on product itself, not inside a container.

## Precautions for using LCDs/LCMs

See Precautions at [www.newhavendisplay.com/specs/precautions.pdf](http://www.newhavendisplay.com/specs/precautions.pdf)

## Warranty Information and Terms & Conditions

[http://www.newhavendisplay.com/index.php?main\\_page=terms](http://www.newhavendisplay.com/index.php?main_page=terms)