

THIS DRAWING IS UNPUBLISHED. RELEASED FOR PUBLICATION 20  
 © COPYRIGHT 20 BY TYCO ELECTRONICS CORPORATION. ALL RIGHTS RESERVED.

LOC	DIST	REVISIONS					
CE	00	P	LTR	DESCRIPTION	DATE	DWN	APVD
			H	REV PER ECR-06-008849	16MAY2006	BB	DK
			J	REVISE PER ECR-09-000232	09JAN2009	BB	DK

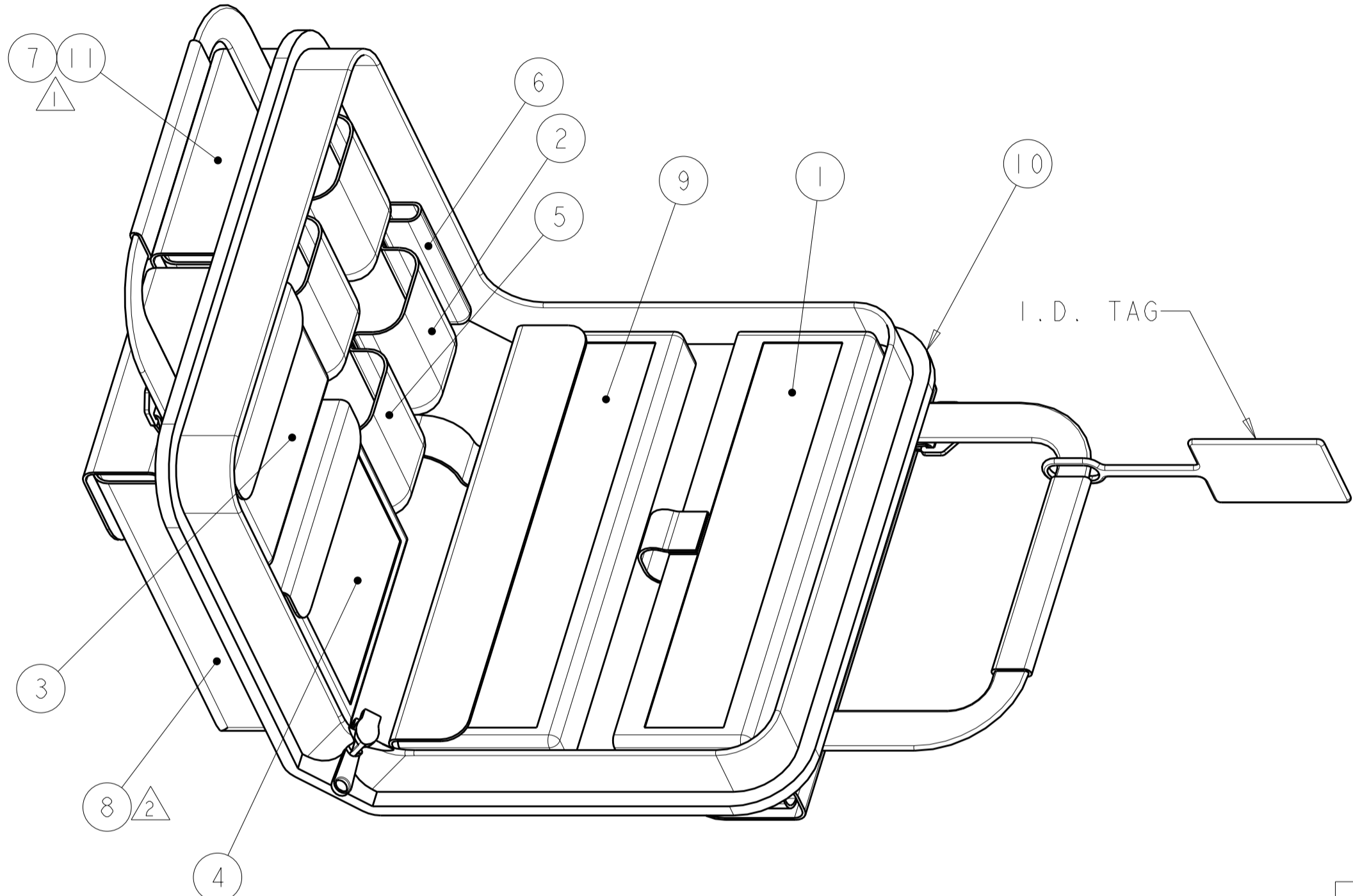

- 1. TE INSTRUCTION SHEETS AND MANUFACTURER'S INSTRUCTION SHEETS.
- 2. OPTIONAL SHOULDER STRAP.
- 3. INSTRUCTION SHEETS 408-4471 EXPLAINS THE LightCrimp Plus SC TERMINATION TECHNIQUES AND ARE AVAILABLE FOR DOWNLOAD AT [www.tycoelectronics.com/documents](http://www.tycoelectronics.com/documents).

1	1	2064710-1	FIBER OPTICS CLEANING & INSPECTION GUIDE	11
1	1	1278540-1	PREMIUM SOFTCASE	10
1	-	1754767-1	200x MICROSCOPE	9
1	1	1871696-1	FIBER CLEAVER, SLIDE CUTTER	8
1	1	1374503-1	CD ROM, TERMINATION TRAINING	7
2	2	1278422-1	OPEN END WRENCH, 1/4	6
1	1	1278637-1	KEVLAR SHEARS	5
1	1	1278023-1	CABLE CLAMP, LightCrimp Plus SC	4
14	14	501857-2	ALCOHOL WIPES	3
1	1	1754708-1	FIBER STRIP TOOL, COMB.	2
1	1	492782-1	HAND TOOL WITH DIESET, SC	1
-2	-1	PART NUMBER	DESCRIPTION	ITEM NO.

<small>THIS DRAWING IS A CONTROLLED DOCUMENT FOR TYCO ELECTRONICS CORPORATION. IT IS SUBJECT TO CHANGE AND THE CONTROLLING ENGINEERING ORGANIZATION SHOULD BE CONTACTED FOR THE LATEST REVISION.</small>		DWN B. BRIGGS 16MAY2006 CHK D. KIRSCH 16MAY2006 APVD S. BUCHTER 16MAY2006	Tyco Electronics Harrisburg, PA 17105-3608
DIMENSIONS: mm 	TOLERANCES UNLESS OTHERWISE SPECIFIED: 0 PLC ± 1 PLC ± 2 PLC ± 3 PLC ± 4 PLC ± ANGLES ± FINISH	PRODUCT SPEC APPLICATION SPEC WEIGHT	NAME <b>TERMINATION KIT, LightCrimp Plus, AMP SC</b>
MATERIAL		SCALE	RESTRICTED TO
		A200779C-1278022	
		CUSTOMER DRAWING	SHEET 1 OF 1 REV J